

# MiG-19S (S-105) Farmer C

Mikojan-Gurjevič MiG-19 (v kódu NATO „Farmer“) byl sovětský dvoumotorový, jednomístný proudový stíhací letoun, kterým byla vyzbrojena od roku 1958 i Československá lidová armáda. Šlo o srovnatelný letoun s americkým North American F-100 Super Sabre, i když MiG-19 později nad Severním Vietnamem čelil modernějším letounům McDonnell Douglas F-4 Phantom II a Republic F-105 Thunderchief.

V roce 1957 obdrželo československé letectvo 27 stíhacích MiGů-19P. V roce 1958 bylo do výzbroje zařazeno 12 ks MiGů-19S, které byly dodány v prosinci 1957. MiG-19 se v Československu vyráběl i sériově ve firmě Aero Vodochody pod označením S-105.

The Mikoyan-Gurevich MiG-19 Farmer is a Soviet second generation, single-seat, twin jet-engined fighter aircraft, the world's first mass-produced supersonic aircraft. A comparable U.S. "Century Series" fighter was the North American F-100 Super Sabre, although the MiG-19 would primarily oppose the more modern McDonnell Douglas F-4 Phantom II and Republic F-105 Thunderchief over North Vietnam.

MiG-19S was improved day fighter with all-moving slab tail. Equipped with Svod long-range navigation receiver and armed with three 30 mm NR-30 cannons. Had provisions for an ORO-32K rocket unguided rocket pack or a FAB-250 bomb under each wing, and from 1957 modified to allow four rocket pods to be carried. Entered production in 1956.

## Plastic parts

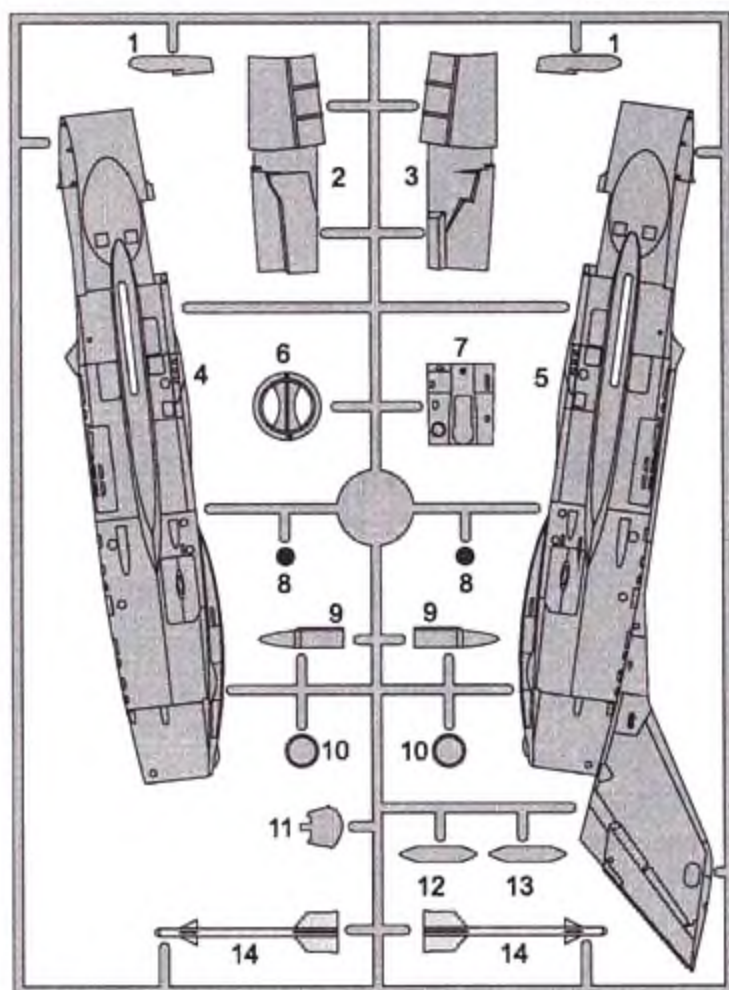

**Clear parts**  C1

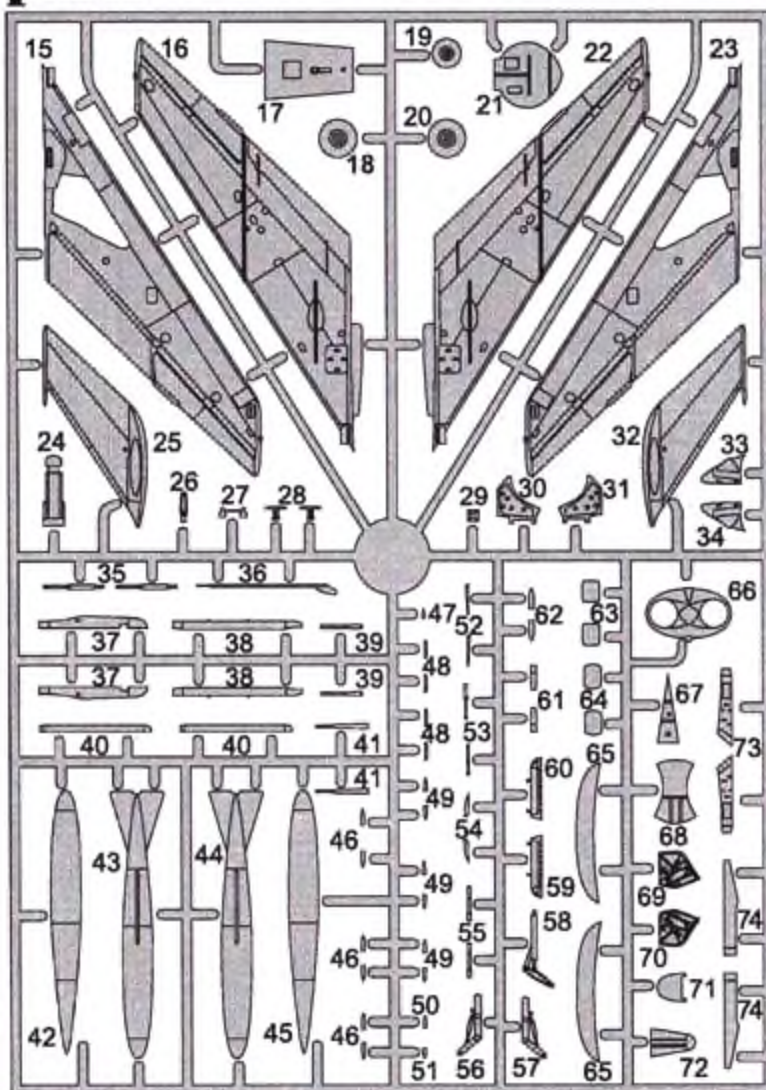

### Symbols/Symboly

 Drill hole Vyvrátat	 Cyanocrylate Vteřinové lepidlo	 Remove Odstranit	 Reduce Zbrousit
 Make new Vyrobit	 Option Volba	 Bend Ohnout	 Putty Tmel

### REALIZAČNÍ TÝM: / REALISATION TEAM:

Předlohový model:  
Master model:  
Titulní kresba:  
Box art:  
Návod:  
Instruction leaflet:  
Grafika a návrh obtisků:  
Graphic design, decals:  
Tisk obtisků:  
Decal printer:

Petr Muzikant  
3D Pavel Vandellík  
Jaroslav Velc  
Zdeněk Macháček

JardaŠ

Jan Polc

KP - Kovozávody Prostějov

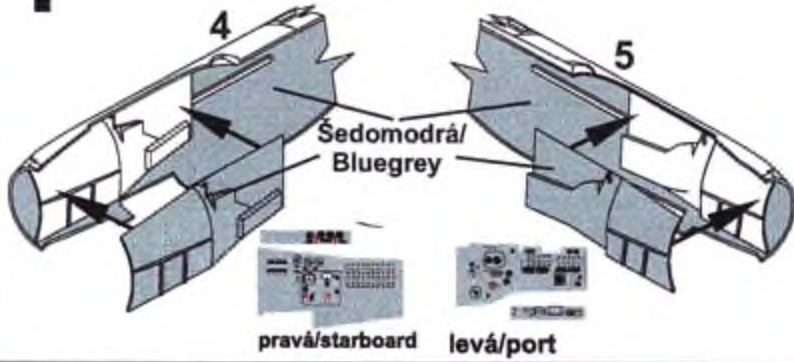
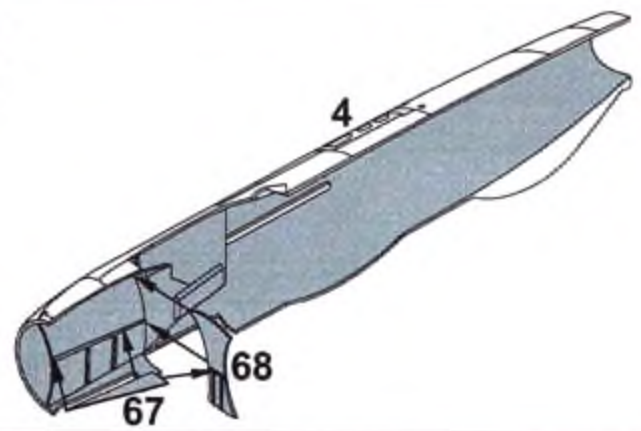
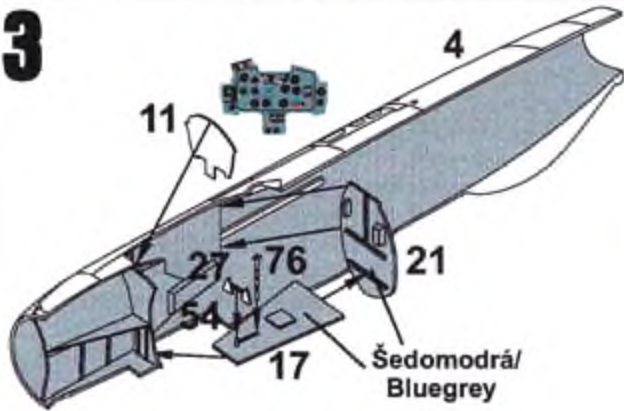
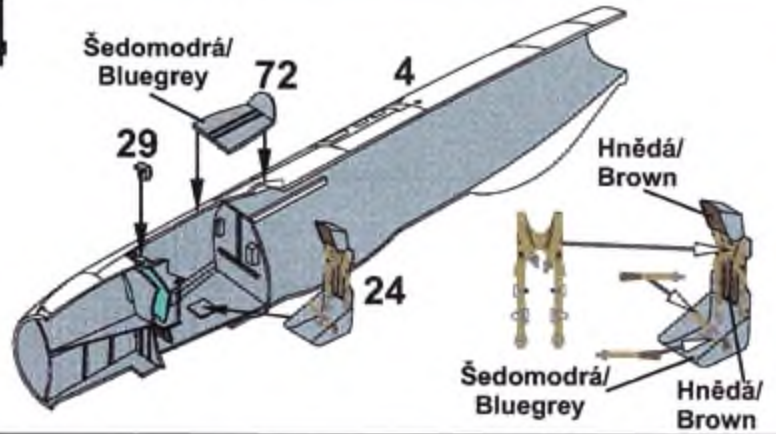
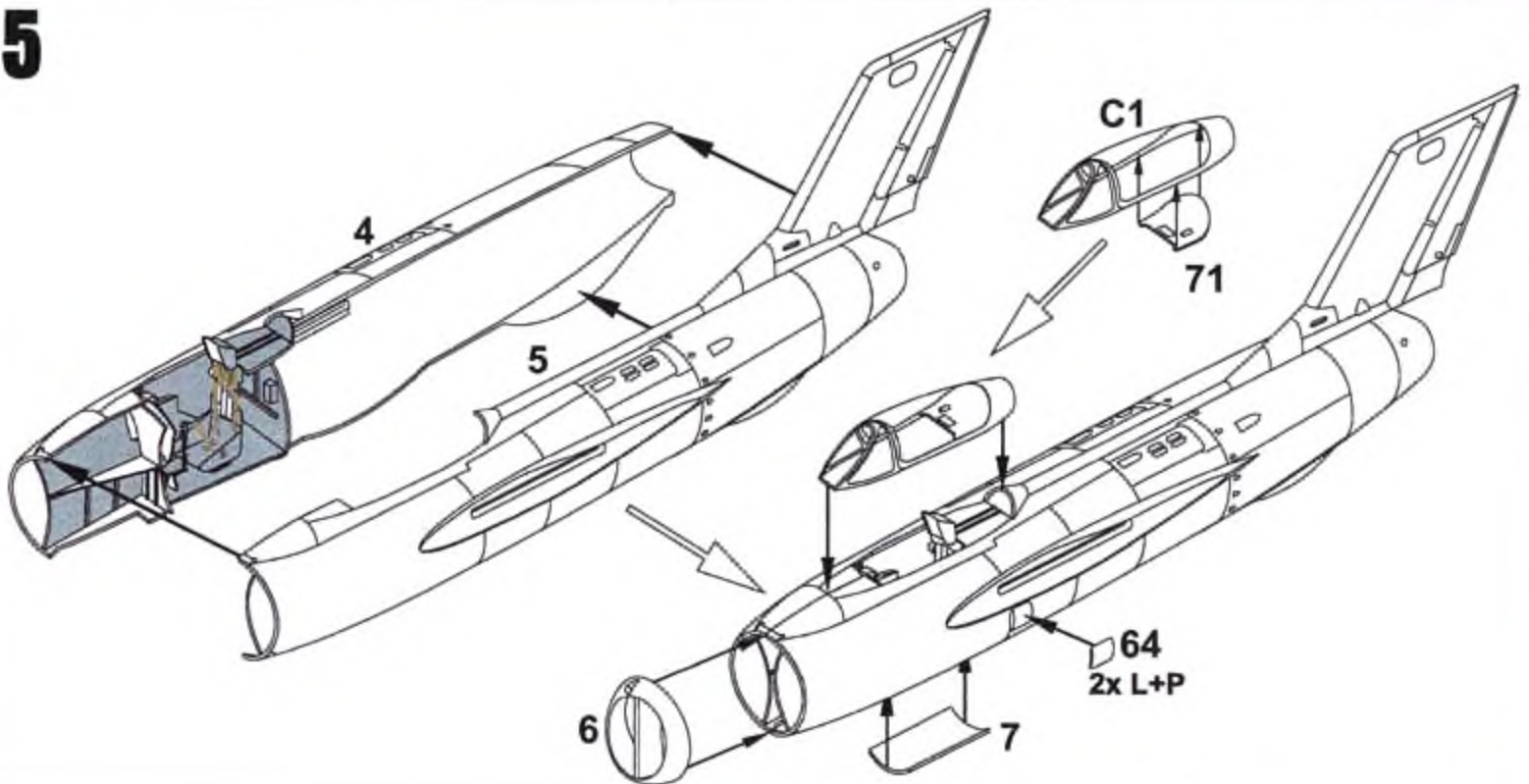
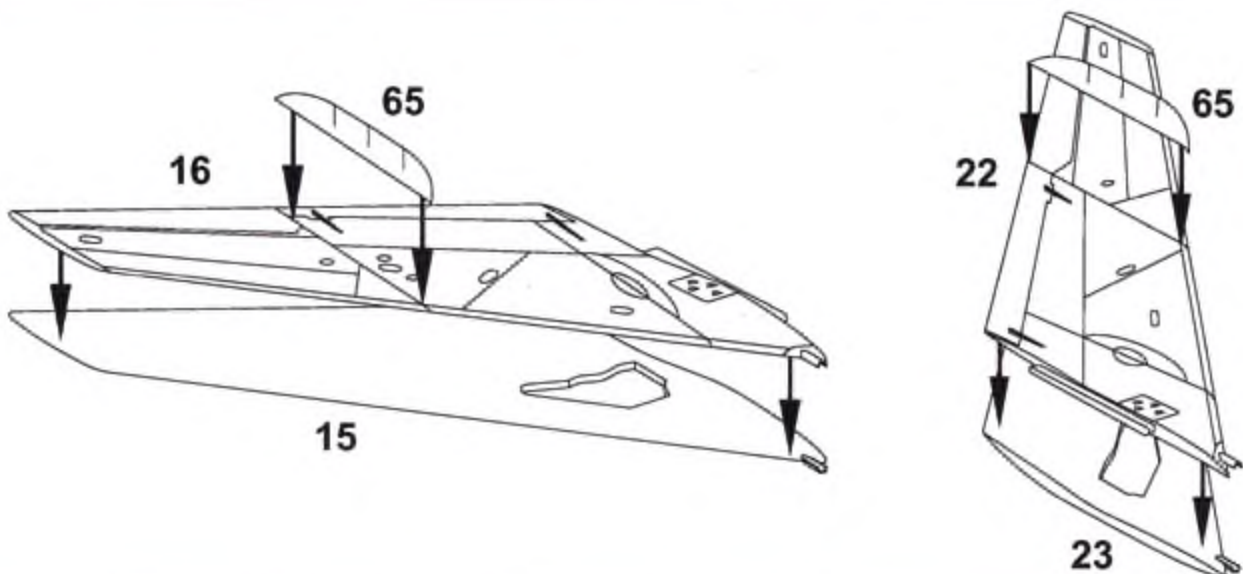
**1****2****3****4****5****6**

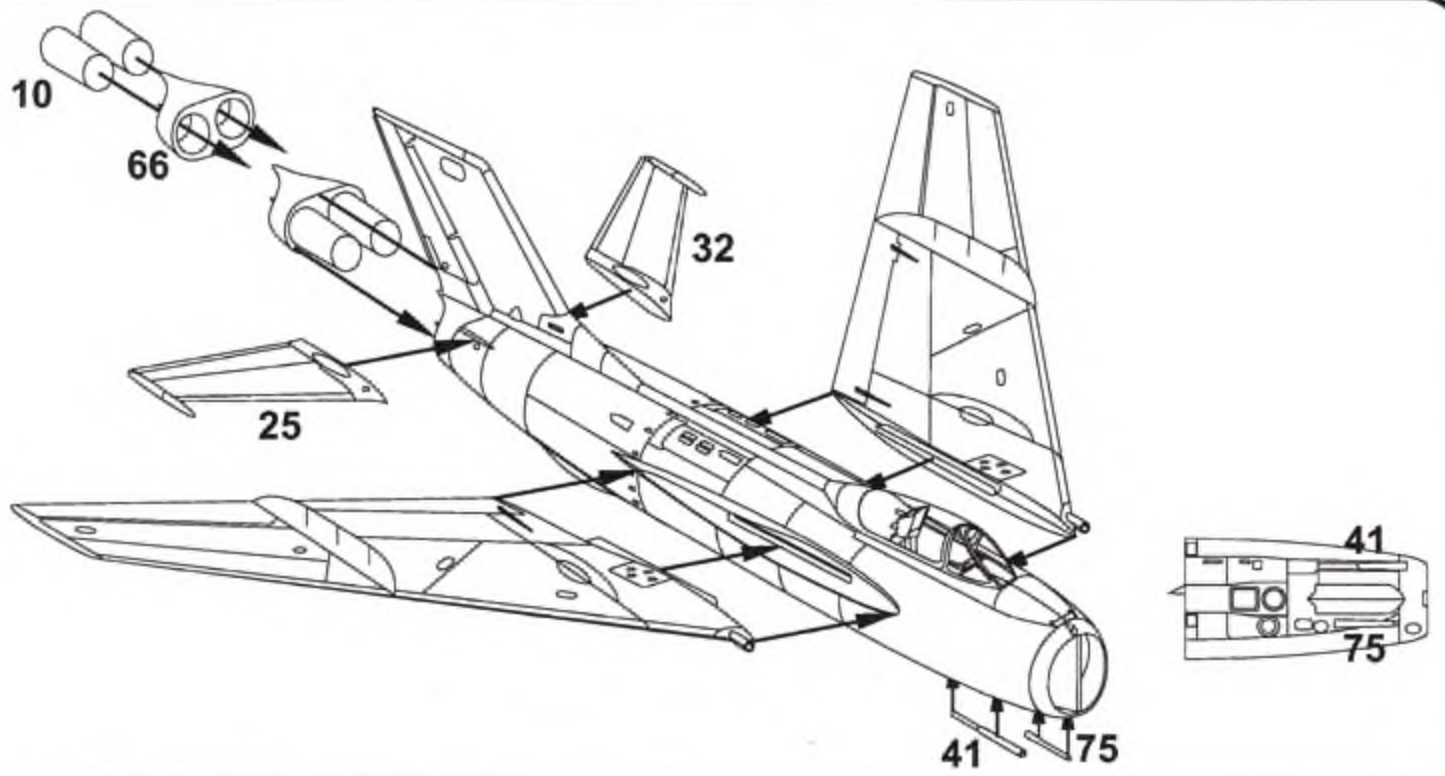
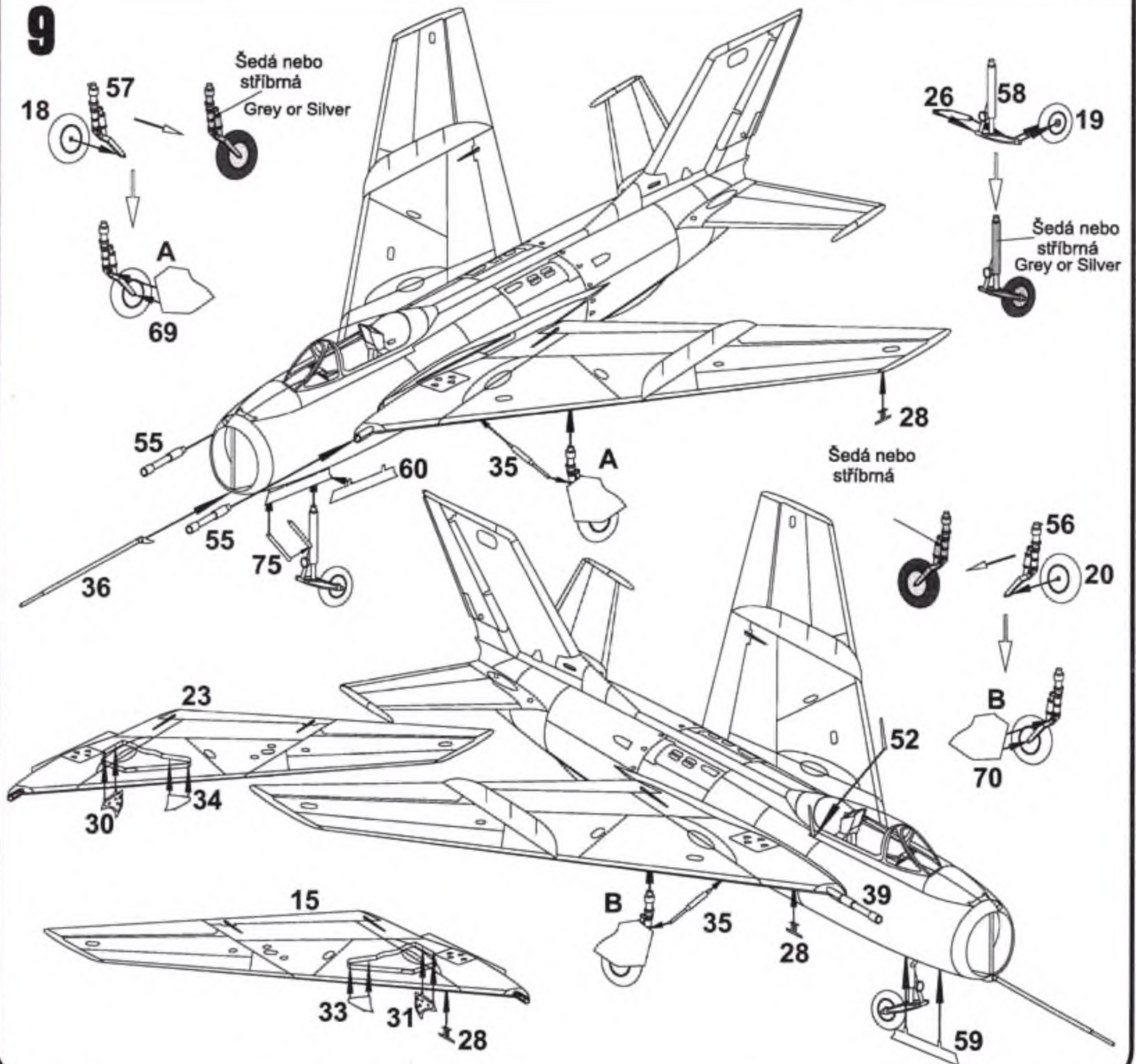
**8****9**

# 11

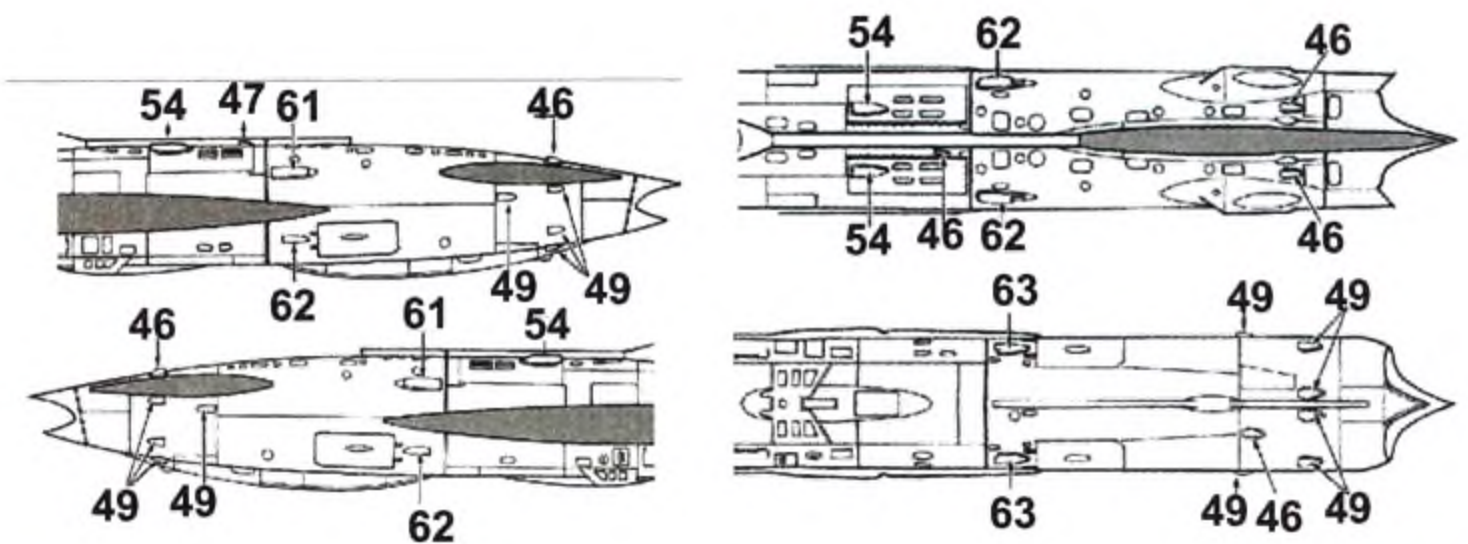
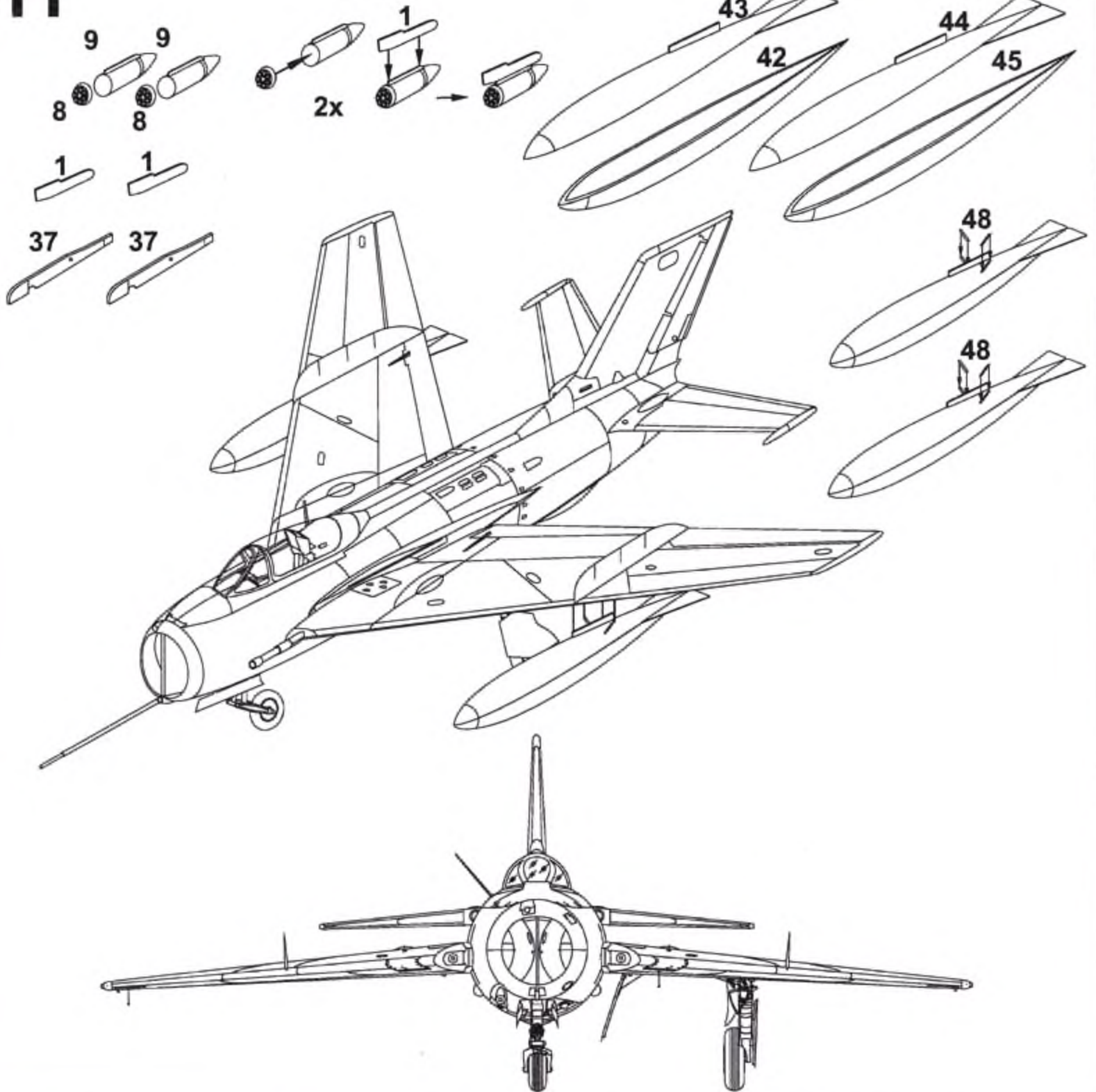

**1** MIG-19S Farmer C, „červená 872“, Jagdgeschwader 3, východoněmecké letectvo, 1968.  
MIG-19S Farmer C, „Red 872“, Jagdgeschwader 3 East German AF, 1968.

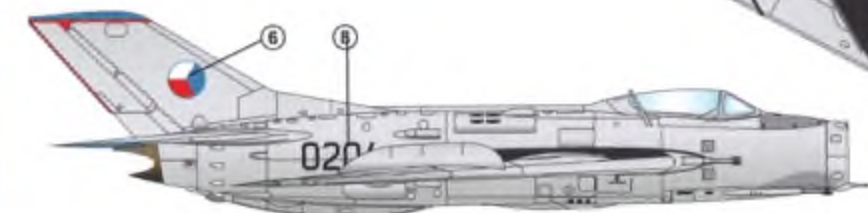
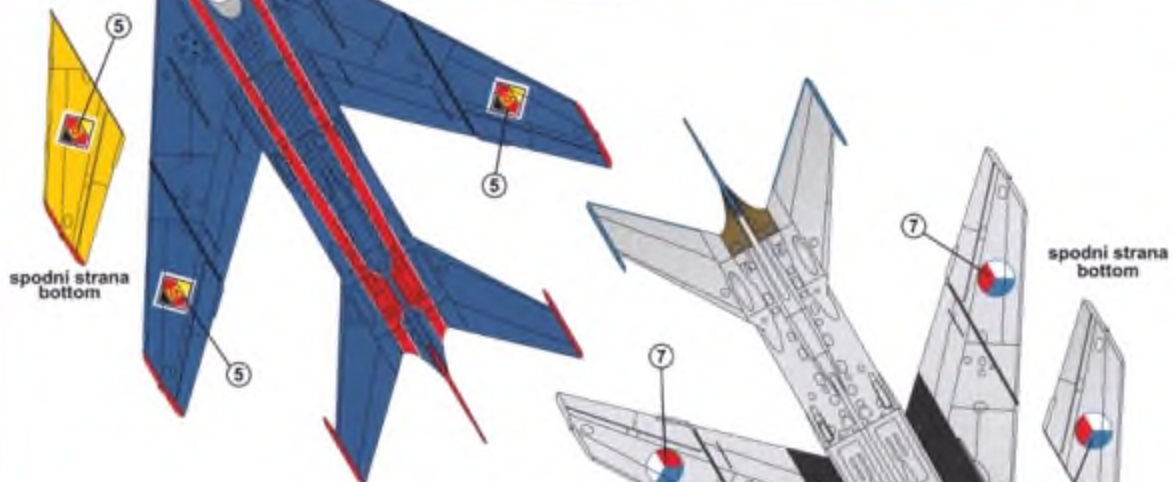

**2** MIG-19S (S-105) Farmer C, „černá 0204“, 1. letka, 9. stíhací letecký pluk, akrobatická skupina „Box“, československé letectvo, letiště Bechyně, 1964.  
MIG-19S (S-105) Farmer C, „Black 0204“, 1st Flight, 9th Fighter Regiment, „Box“ aerobatic team, Czechoslovak AF, Bechyne AB, 1964.

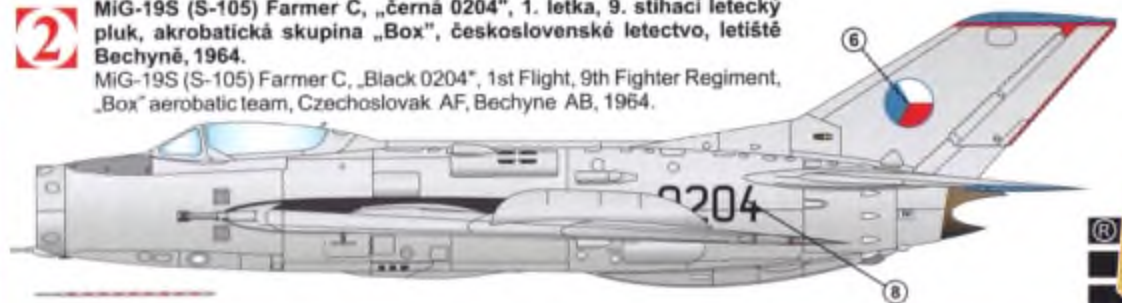

**Možnosti zbarvení  
Camouflage options**

56 47

Hliník  
Aluminium

19 17

Červená  
Red

14 05

Modrá  
Blue

25 18

Tmavá modrá  
Dark Blue

69 C51

Žlutá  
Yellow

128 A30

Střední šedá  
Mid Grey

85 N46

Černošedá  
Blackgrey

73 42

Tmavá červená  
Dark Red

171 47

Tmavá ocel  
Dark Steel

53 57

Barva hlavní  
Gunmetal

87 N5

Šedomodrá  
Bluegrey

Použité barvy: / Paints used:  
**SUMBROL / AGAMA**



**3** MIG-19S Farmer C, „černá F 1904“, akrobatická skupina indonéskeho letectva, 1966.  
MIG-19S Farmer C, „Black F 1904“, Indonesian AF Display Team, 1966.

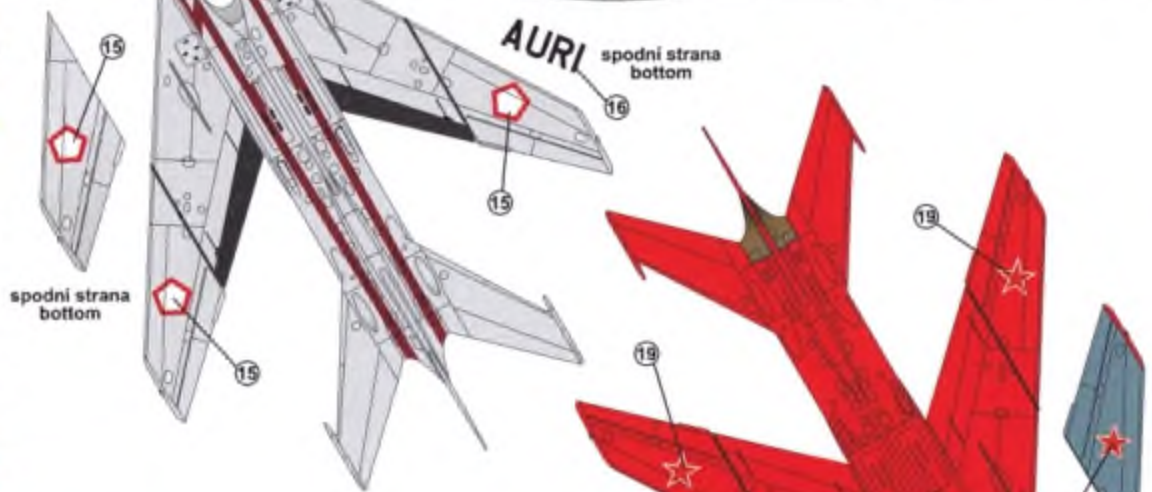
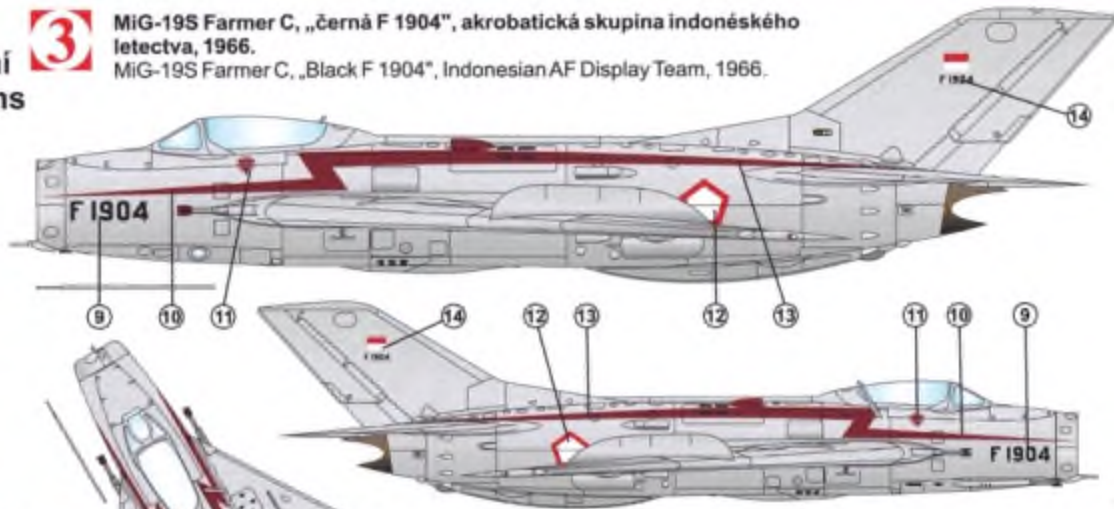

**4** MIG-19S Farmer C, „žlutá 45“, akrobatická skupina sovětského letectva, letiště Kubinka, 1960.  
MIG-19S Farmer C, „Yellow 45“, VVS Display Team, Soviet AF, Kubinka AB, 1960.

