

USE ENAMEL OR PLASTIC PAINTS ONLY.
DO NOT USE LACQUER PAINT MATERIALS
AS THESE CRAZE THE PLASTIC

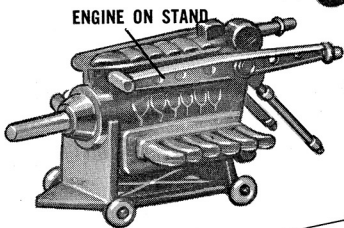

NOTE: COWLING MAY BE
CEMENTED IN POSITION
SHOWN IF DESIRED.

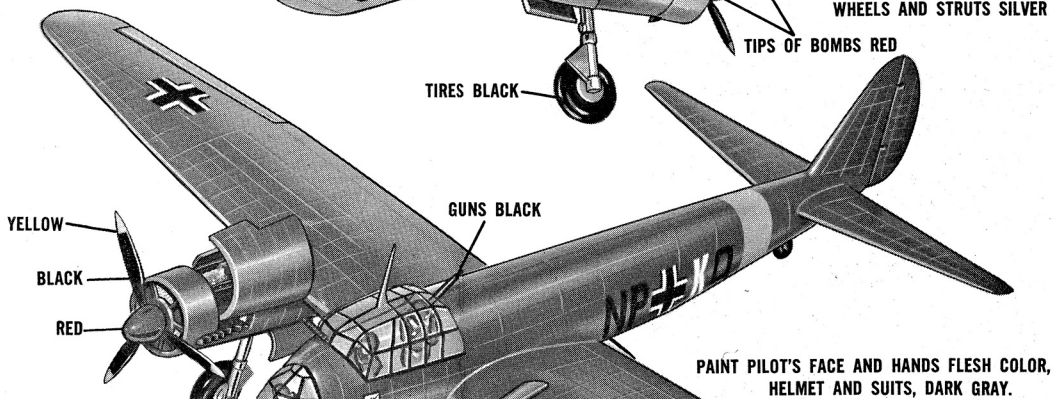
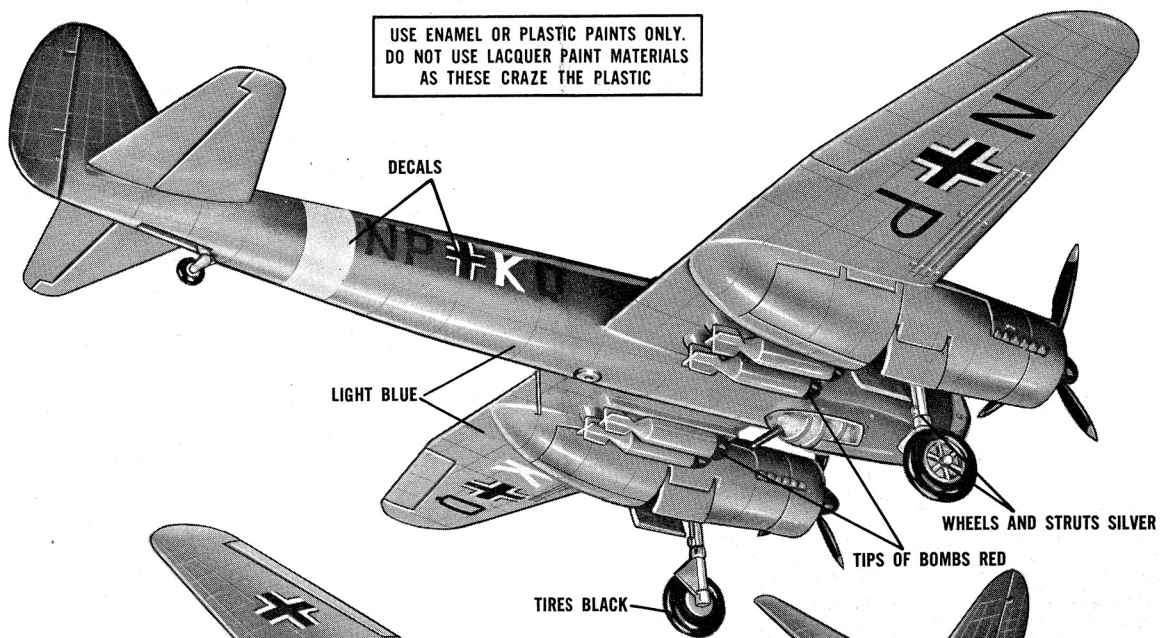
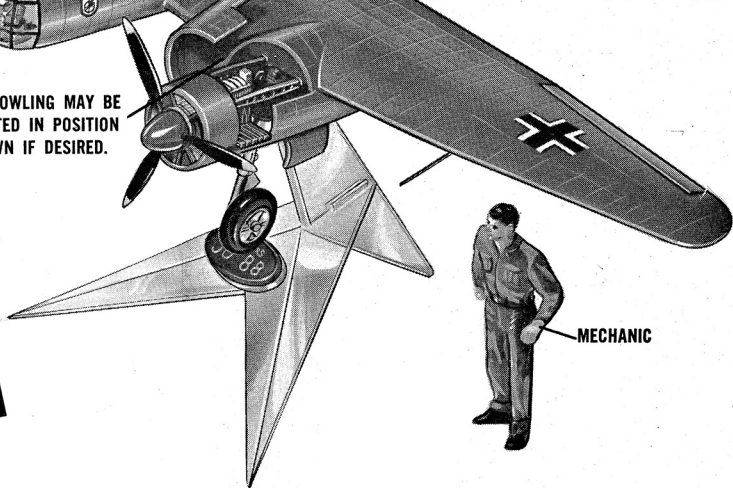

ASSEMBLY PLANS FOR THE

KIT NO. 545

JUNKERS JU-88

The JU-88 was probably the most versatile of Germany's wartime combat aircraft. It served on all fronts being used as a day and night fighter, and for dive and level bombing of both land and sea targets. The bomber version of this aircraft was fitted with jettisonable rocket devices under the wings to assist in take-off. The many versions included the use of various powerplants, different radio equipment, structural variations, etc. Wing span—66 ft. Length—47 ft. Maximum speed—270 M.P.H. (loaded).

LINDBERG PRODUCTS INCORPORATED, SKOKIE, ILLINOIS

the LINDBERG line[®]

ESTABLISHED SINCE 1933

EASY TO ASSEMBLE

USE CEMENT SPARINGLY FOR BEST APPEARANCE AND STRENGTH OF THE MODEL

ASSEMBLY SUGGESTION

While cementing, scotch tape, masking tape or rubber bands may be used to hold parts in position as they dry.

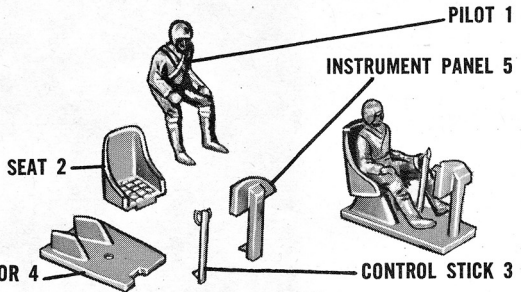

1

Cement pilot (1) to seat (2), then to cockpit floor (4). Cement control stick (3) and instrument panel (5) to cockpit floor.

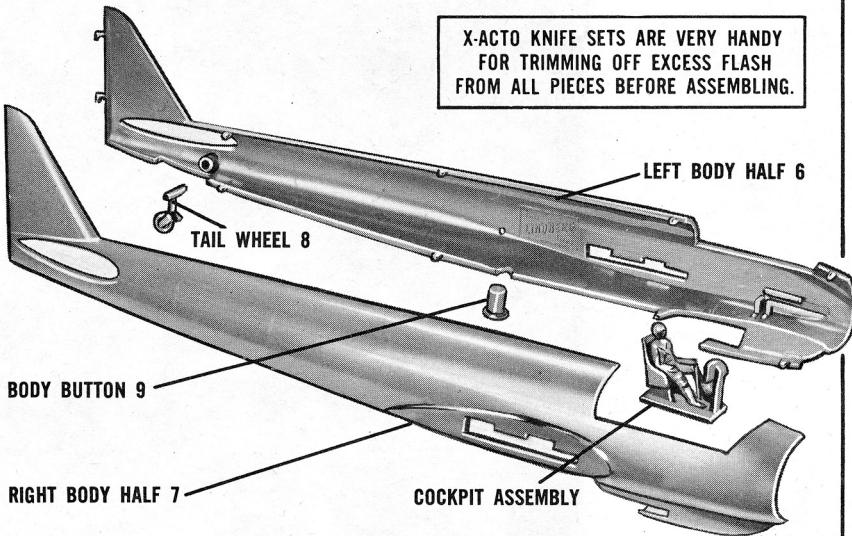

X-ACTO KNIFE SETS ARE VERY HANDY FOR TRIMMING OFF EXCESS FLASH FROM ALL PIECES BEFORE ASSEMBLING.

2

Cement cockpit assembly and body button (9) into left body half (6). Place tail wheel (8) in position and cement left and right (7) body halves together.

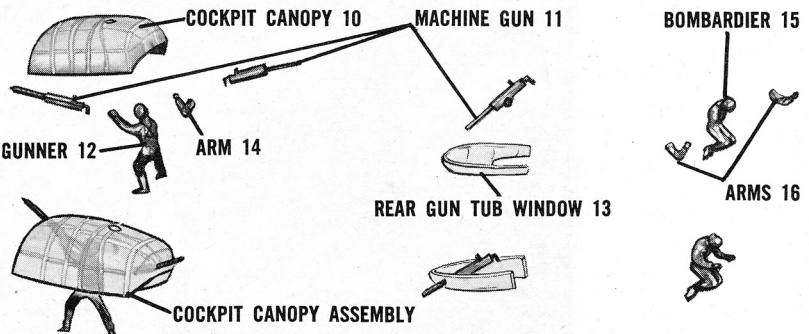

3

Cement arm (14) to gunner (12) and machine gun (11) to gunner's arms. Now cement gunner with gun into cockpit canopy (10), and machine gun into notch in canopy. Next cement machine gun into rear gun tub window (13). Cement arms (16) to bombardier (15).

SEMBLE STEP BY STEP INSTRUC

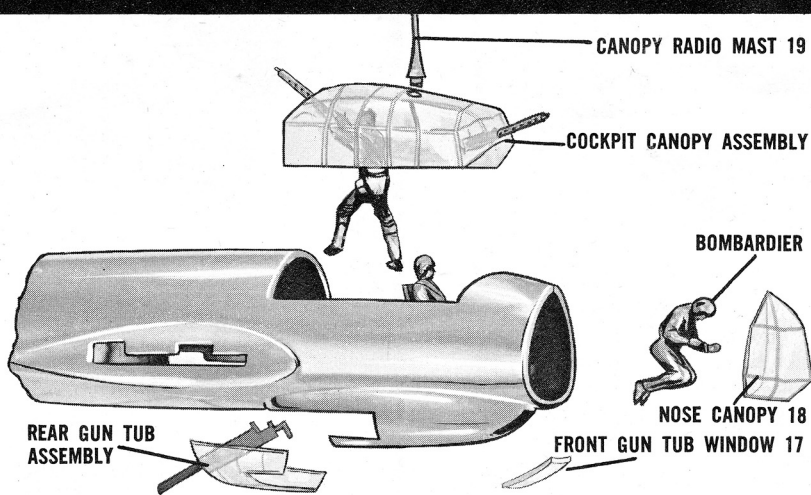

4 Cement the cockpit canopy assembly, rear gun tub assembly, front gun tub window (17), bombardier, and nose canopy (18) to the body. Cement canopy radio mast (19) to top of canopy.

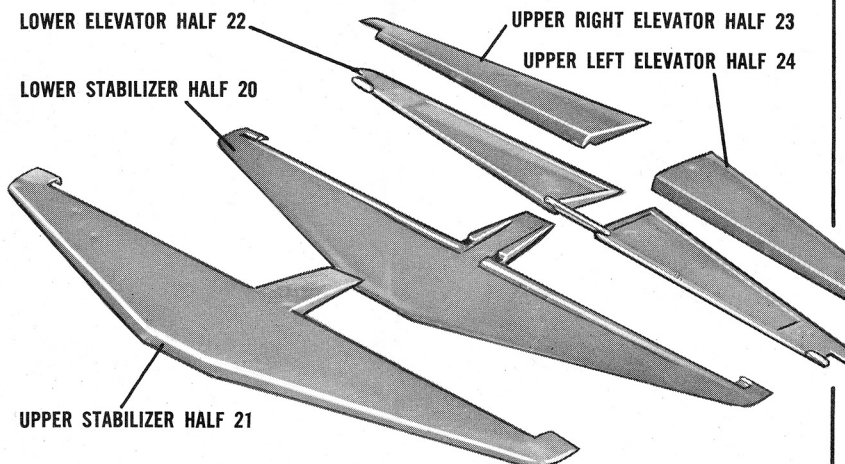

5 Cement upper left (24) and right (23) elevator halves to lower elevator half (22), place into lower stabilizer half (20) and cement upper stabilizer half (21) to lower half.

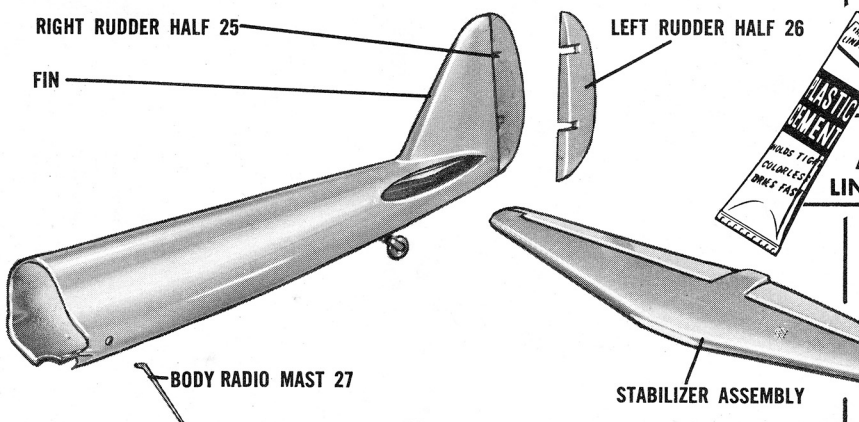

6 Place right rudder half (25) in position on fin and cement left rudder half (26) to right half. Slide stabilizer assembly into body and cement. Cement body radio mast (27) to body.

CTIONS

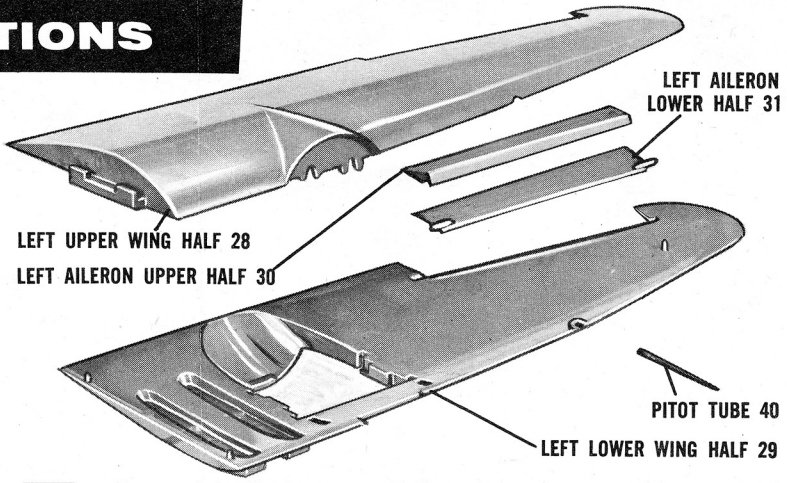

7 Cement left aileron upper (30) and lower (31) halves together, place into left lower wing half (29) and cement left upper wing half (28) to lower half. Cement pitot tube (40) to wing. (Note, pitot tube in left wing only). Repeat this assembly for the right wing. **NOTE: THE AILERON HALVES FOR THE LEFT WING ARE MARKED WITH THE LETTER "L" AND THE AILERON HALVES FOR THE RIGHT WING ARE MARKED WITH THE LETTER "R".**

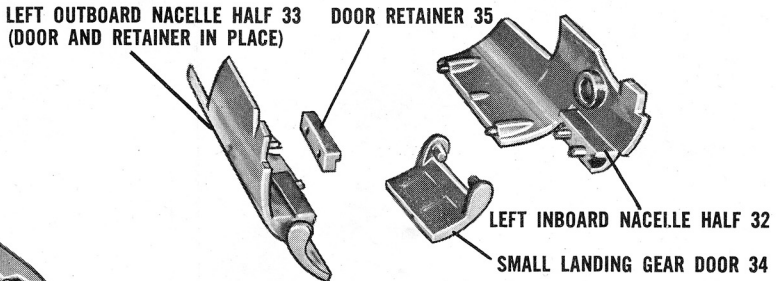

8 Place small landing gear doors (34) into left inboard (32) and outboard (33) nacelle halves and cement door retainers (35) in place. Repeat this assembly for the right nacelle. **NOTE: THE LEFT NACELLE HALVES ARE MARKED WITH THE LETTER "L" AND THE RIGHT NACELLE HALVES ARE MARKED WITH THE LETTER "R".**

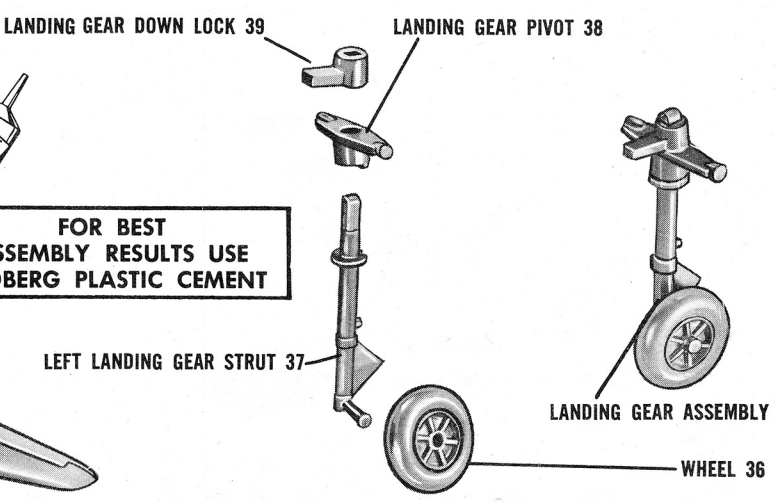

9 Press landing gear pivot (38) onto left landing gear strut (37) and cement landing gear down lock (39) to top of strut as shown. Press wheel onto axle and repeat this assembly for the right gear.

OUTBOARD AND INBOARD
NACELLE ASSEMBLY

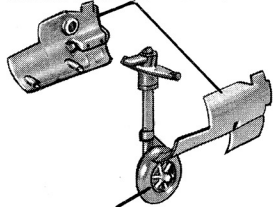

LANDING GEAR ASSEMBLY

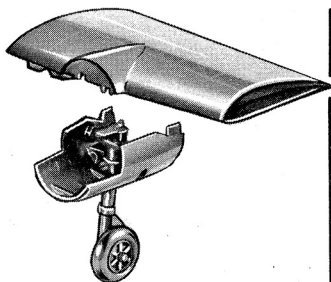

10 Place left landing gear assembly into sockets in outboard and inboard nacelle assemblies and cement nacelle assemblies together. Now cement unit to bottom of left wing. Repeat this assembly for the right gear and nacelle halves.

UPPER BOMB HALF 41

LOWER BOMB HALF 42

LEFT OUTBOARD
WHEEL DOOR 43

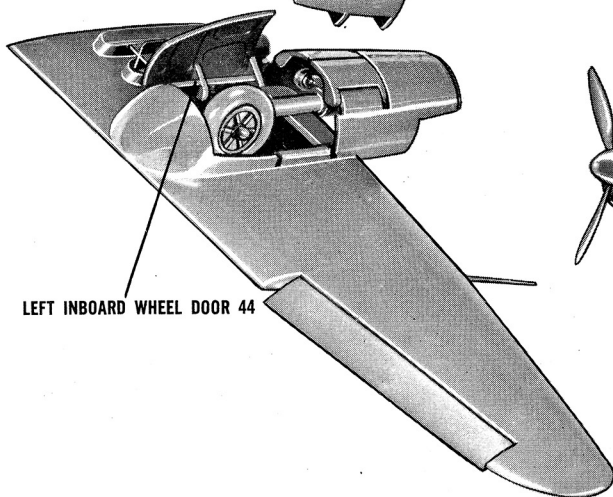
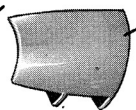
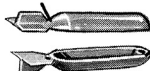

LEFT INBOARD WHEEL DOOR 44

11 Snap left inboard (44) and outboard (43) wheel doors into bottom of left wing. Cement upper (41) and lower (42) bomb halves together and then to bottom of wing as shown. Repeat this assembly for the right wing. NOTE: THE RIGHT WHEEL DOORS ARE MARKED WITH THE LETTER "R" AND THE LEFT WHEEL DOORS ARE MARKED WITH THE LETTER "L".

LEFT ENGINE SIDE 45

RIGHT ENGINE MOUNT 52

LEFT ENGINE MOUNT 51

EXHAUST STACK 50

EXHAUST STACK 50

PROPSHAFT 47

RIGHT ENGINE SIDE 46

RIGHT CYLINDER BANK 48

LEFT CYLINDER BANK 49

12 Place the propshaft (47) into left engine side (45) and cement the following parts together—left and right (46) engine sides, left (49) and right (48) cylinder banks, exhaust stacks (50), and left (51) and right (52) engine mounts. Repeat this assembly for the other engine.

COWLING ASSEMBLY

PROPELLER 55

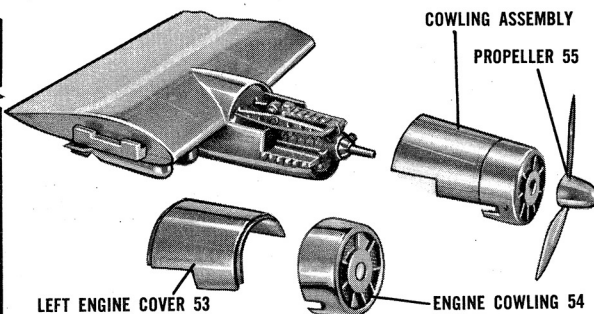

LEFT ENGINE COVER 53

ENGINE COWLING 54

13 Cement left engine cover (53) to engine cowling (54). Place engine into nacelle but do not cement. Place cowling assembly over engine and press propeller (55) onto propshaft. The engine, cowling assembly and propeller are not cemented together, so that the engine can be removed if desired. Repeat this assembly for the right engine and cowling assemblies. NOTE: THE LEFT ENGINE COVER IS MARKED WITH THE LETTER "L" AND THE RIGHT ENGINE COVER IS MARKED WITH THE LETTER "R".

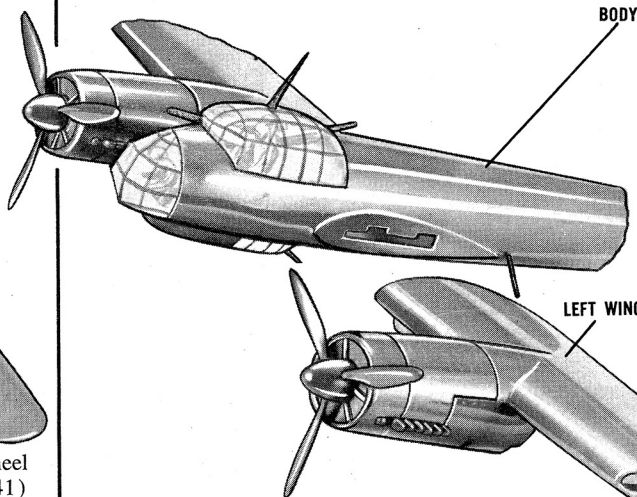

BODY

LEFT WING

14 Cement the left and right wings to the body.

STAND WIRE 61

STAND BUTTON 60

NAMEPLATE 58

NAMEPLATE HOLDER 59

PYLON 57

STAND BASE 56

15 Cement the following stand parts together—stand base (56), pylon (57), nameplate holder (59), nameplate (58), stand button (60), and stand wire (61).

