

Meteor NF.14

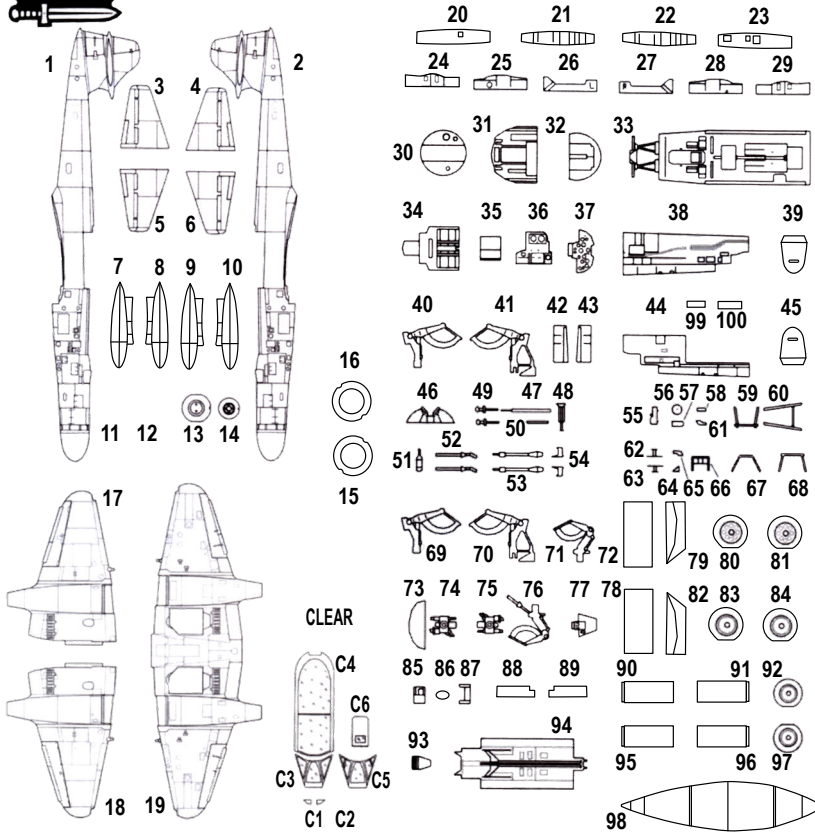

The Gloster Meteor was the first British jet fighter and the only Allied jet to see combat in WWII. It saw service from 27 July 1944. Later, the Meteor was adopted as an interim measure to replace the DH Mosquito as a night fighter. The original proposal by Gloster was based on the two seat trainer, with the navigator in the rear seat. The accepted proposal was turned over to Armstrong Whitworth to develop the design details and build the aircraft. The prototype flew 31 May, 1950. It was based on the T7 with the fuselage and tail of an F8, and the longer wings of an F3. An extended nose enclosed the AI Mk10 Air Intercept radar, and the cannons moved to the wings, outboard of the engines. A ventral fuel tank was added, along with wing mounted drop-tanks. This was the NF.11 Meteor. As technology developed, a newer radar was installed, the nose extended and the fin enlarged. Rolls-Royce Derwent engines were fitted to strengthened wings. This became the NF.12 night fighter. The final version, NF.14, flew 23 October, 1953. Based on the NF.12, the nose was extended a further 17 inches (43.2 cm) to house new equipment, taking the overall length of the aircraft to 51 feet, 4 inches (15.65m). A larger bubble canopy replaced the framed T7 type. Only 100 NF.14 were built and they served from 1954, and replaced as early as 1956 by the Gloster Javelin. Some NF.14s were converted to be used as navigation trainers.



| COLOR | |
|-------|----------------|
| (A) | Interior Black |
| (B) | Silver |
| (C) | Aluminium |
| (D) | Chrome |
| (E) | Gun metal |
| (F) | Tyre Black |
| (G) | Leather |

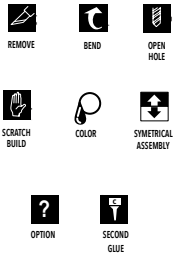

STEP 7

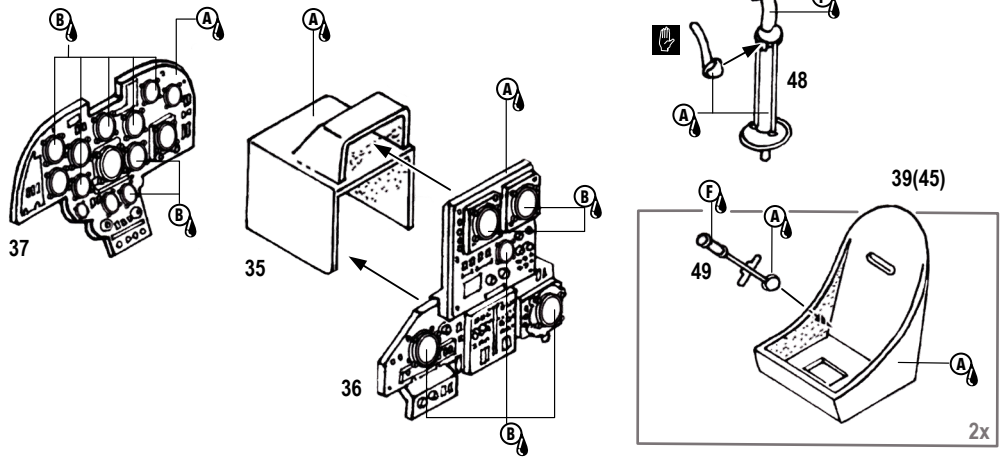

2x

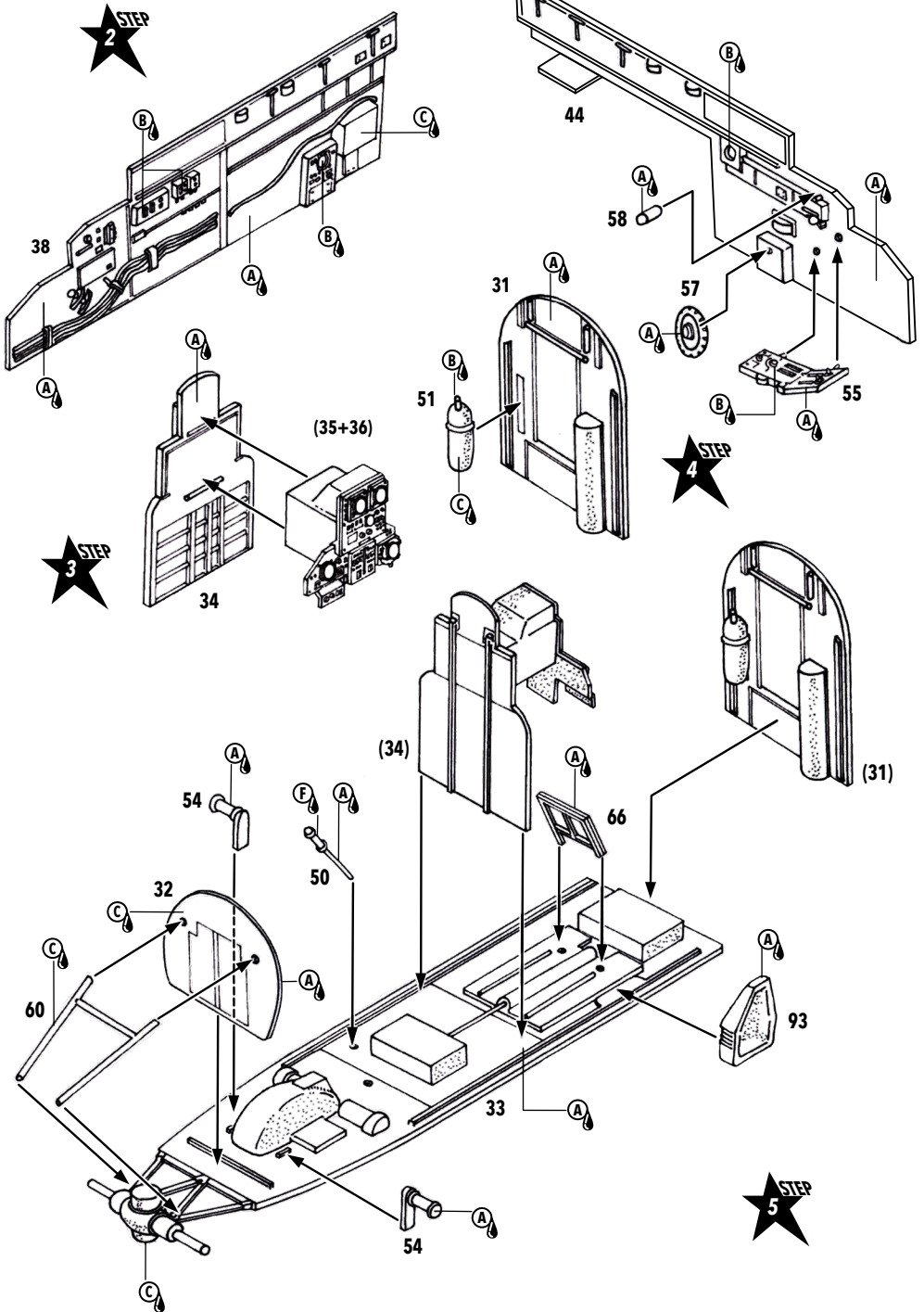

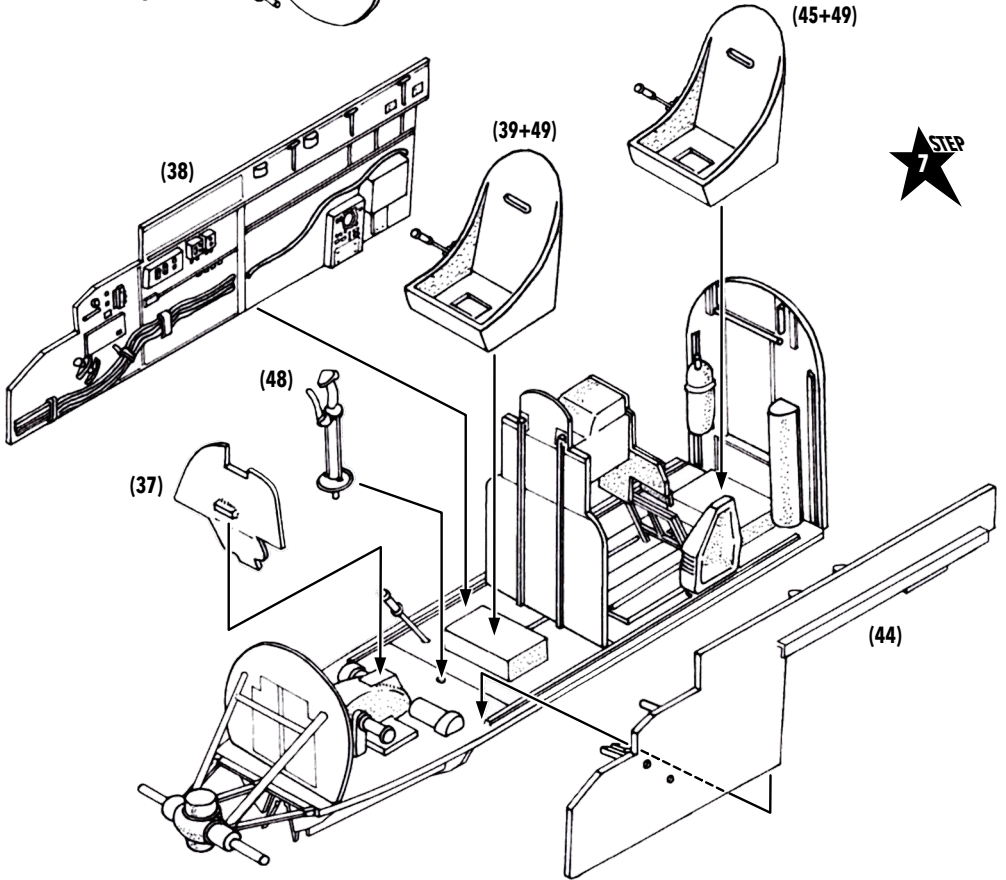
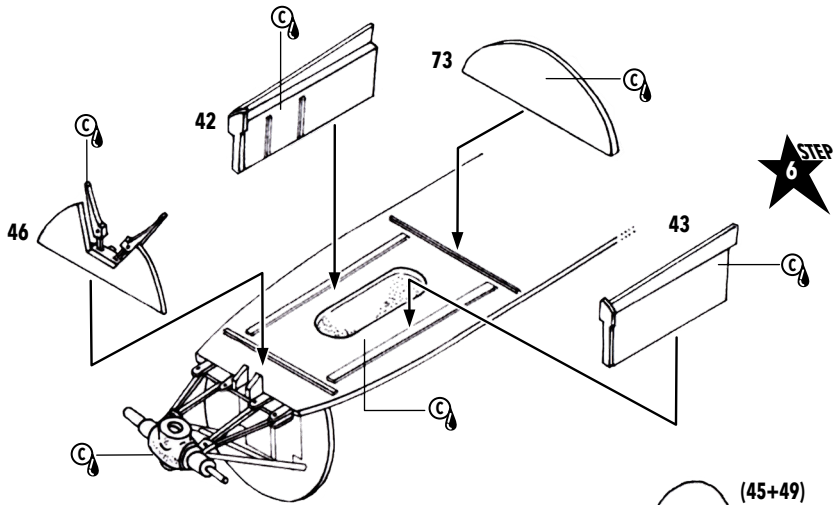

8 STEP

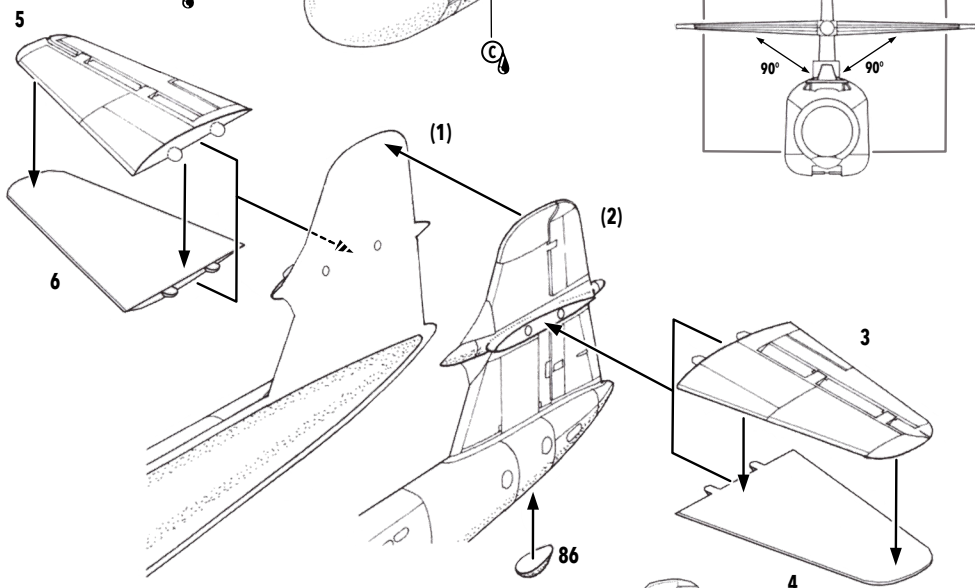
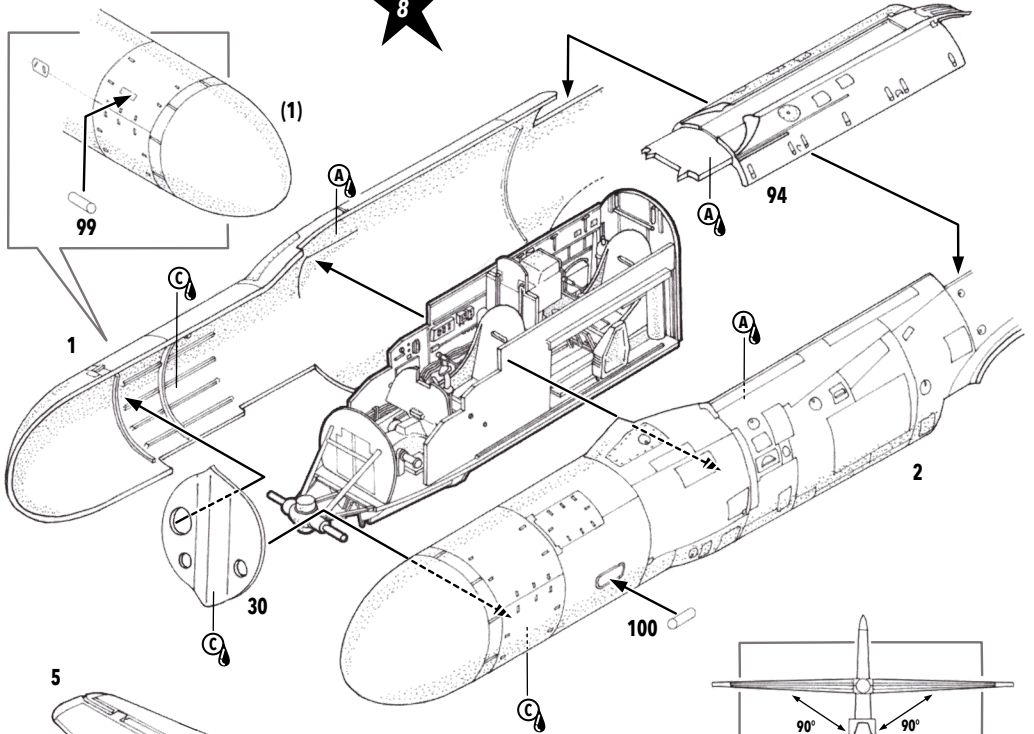

9 STEP

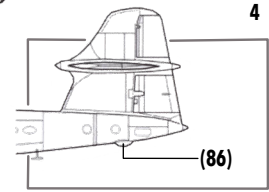

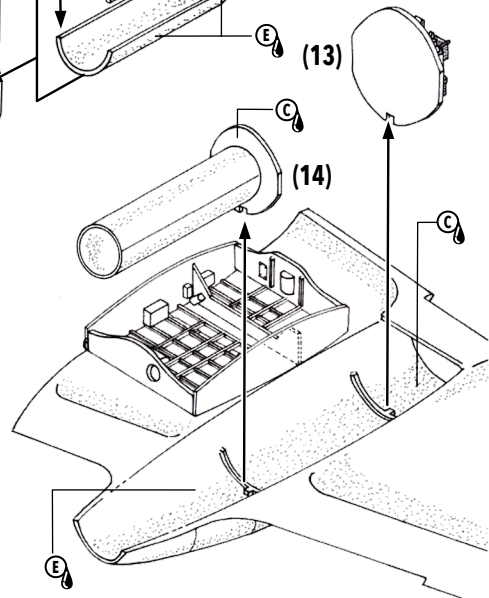
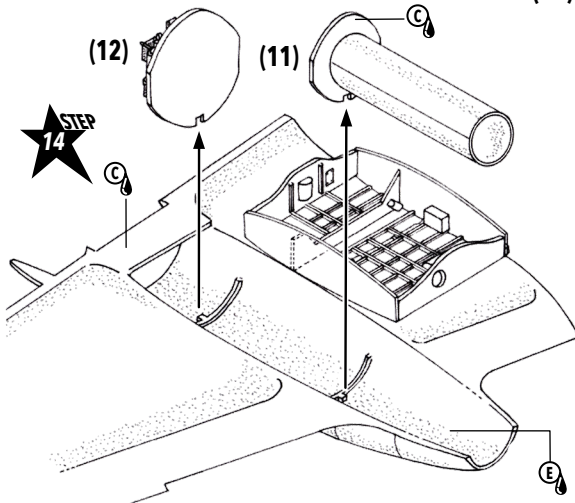
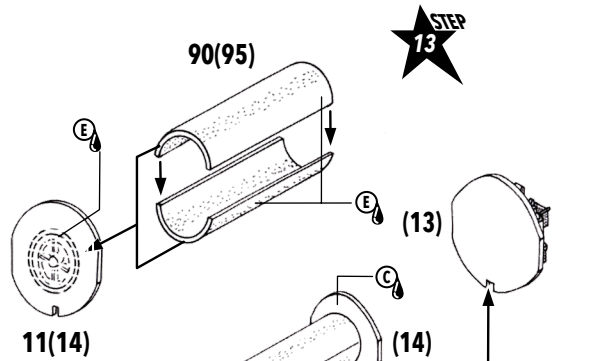
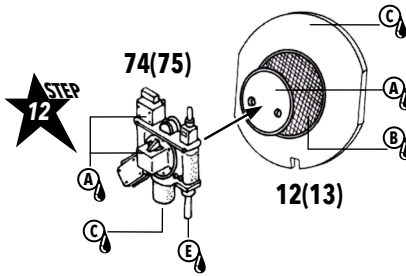
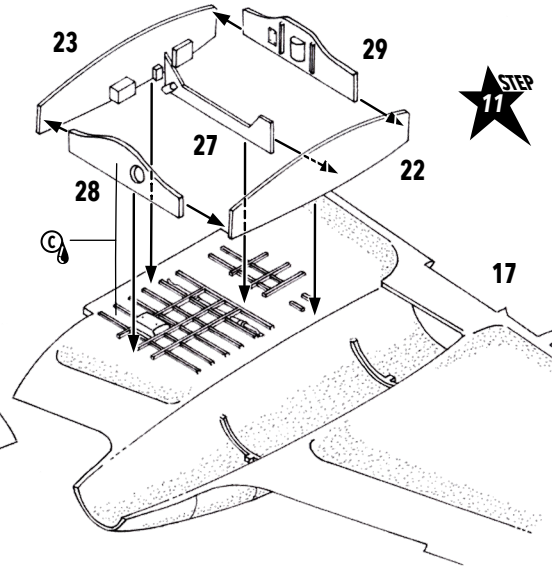
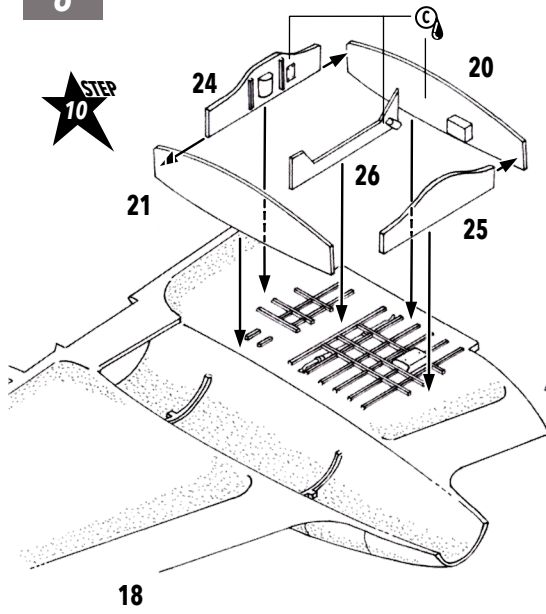

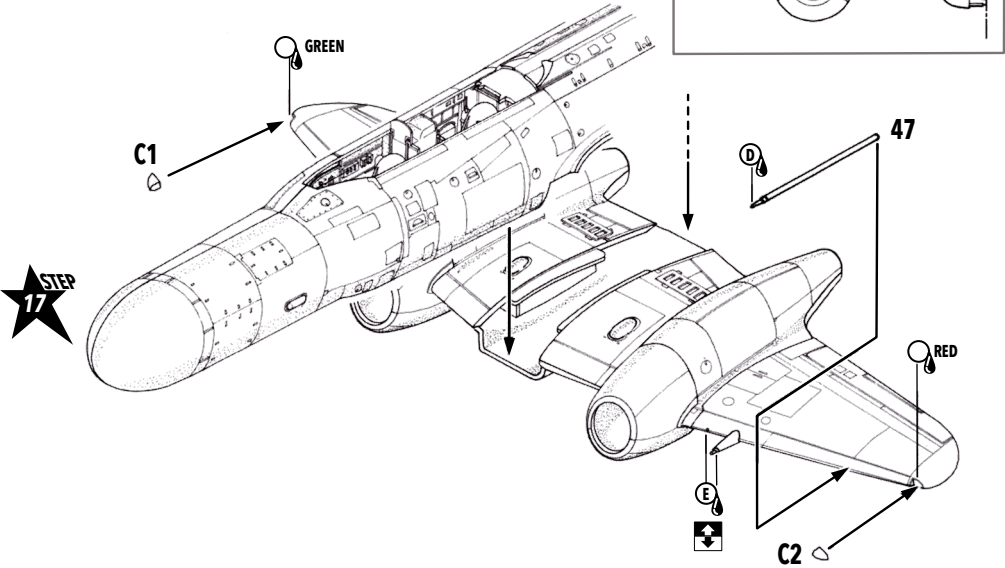
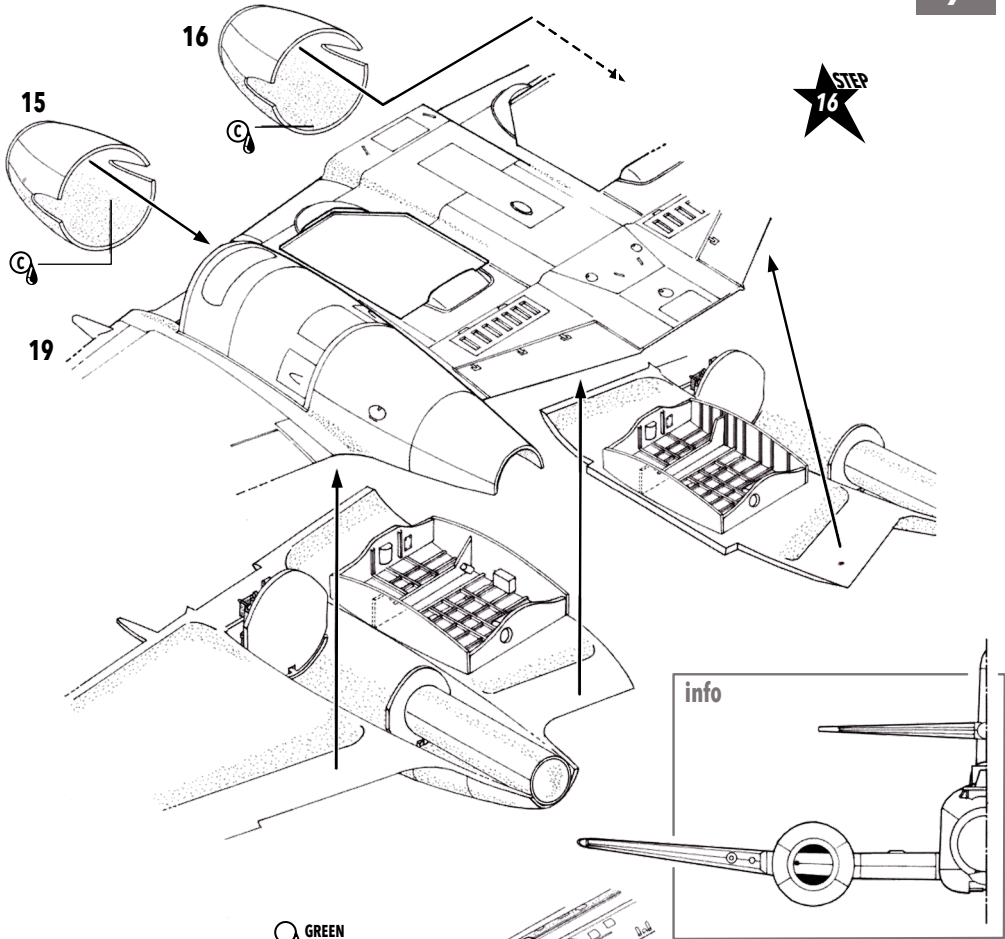

STEP 18

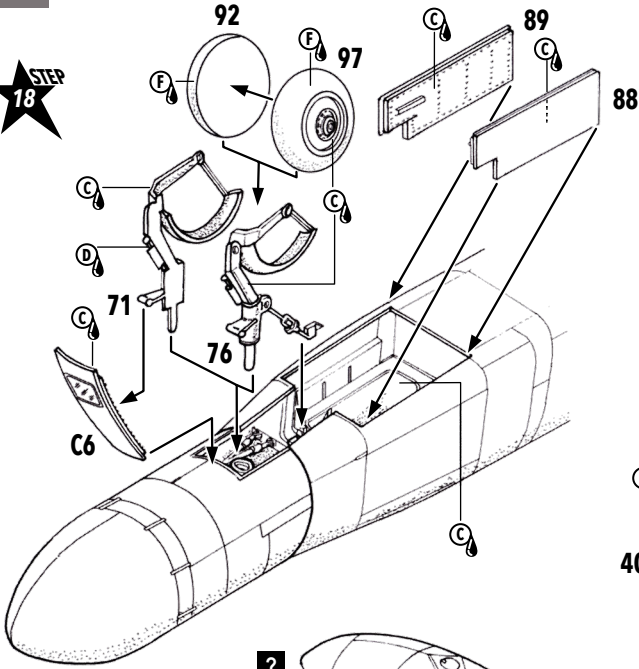

STEP 19

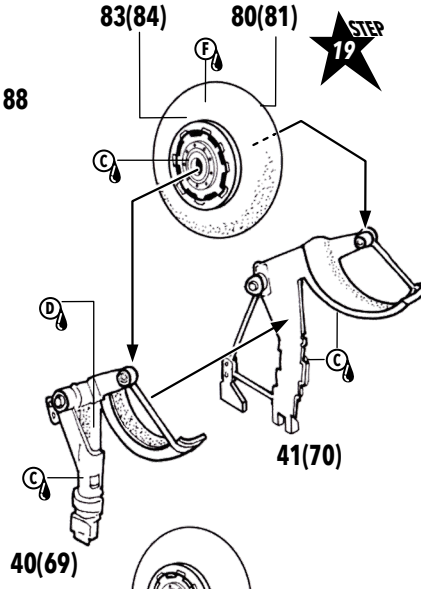

? 98

STEP 20

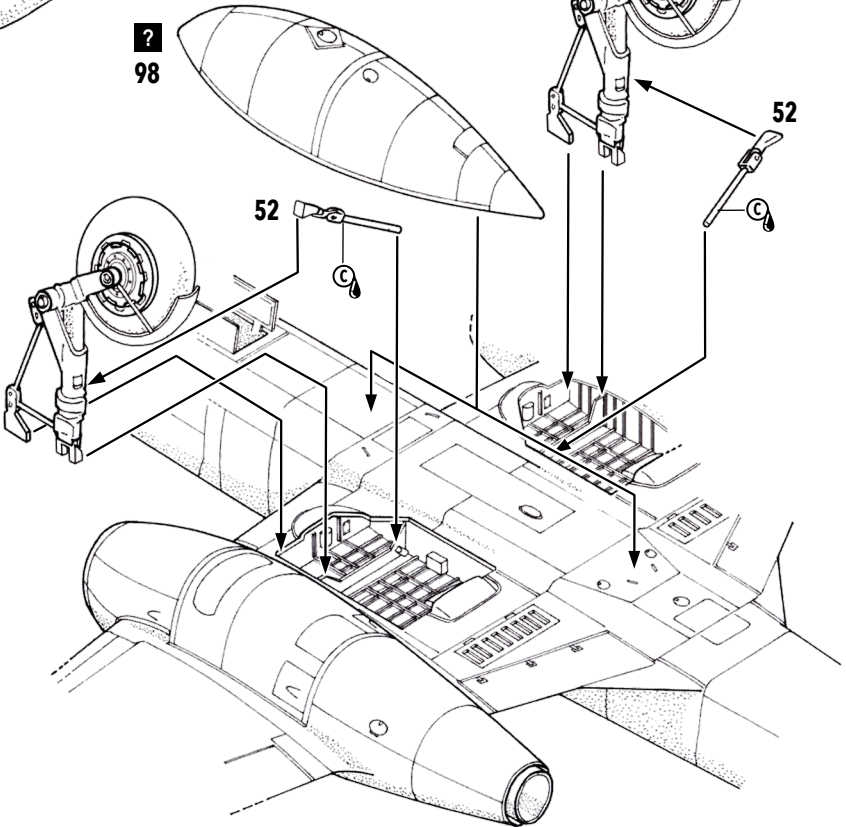

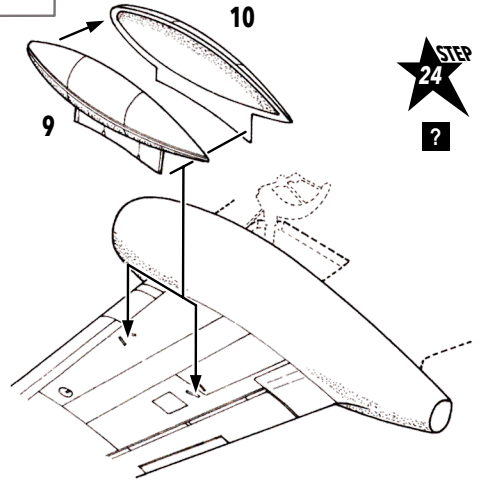
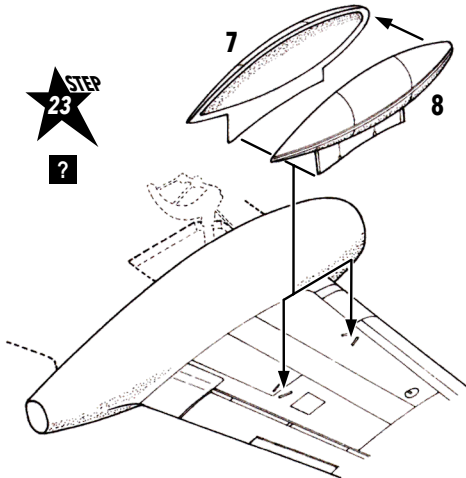
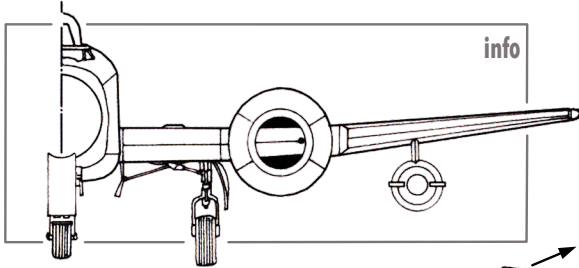
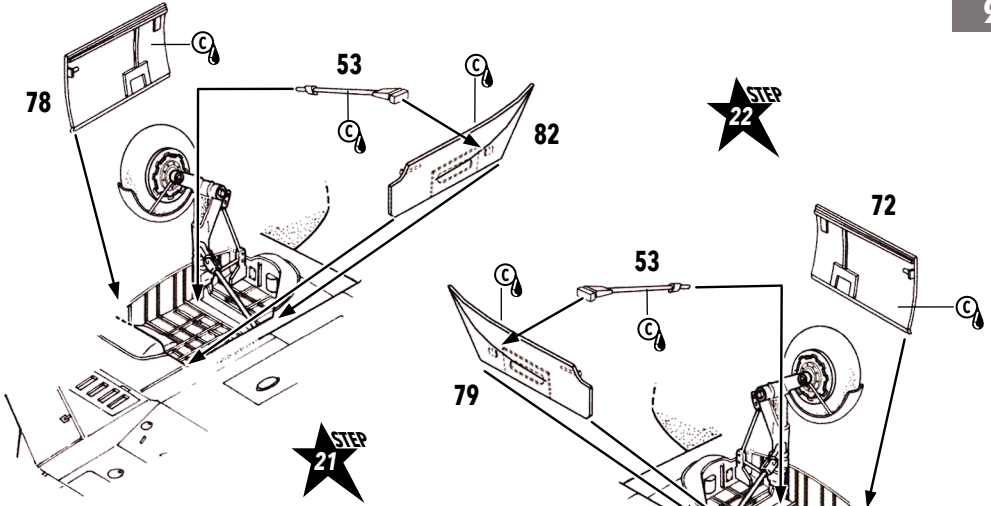

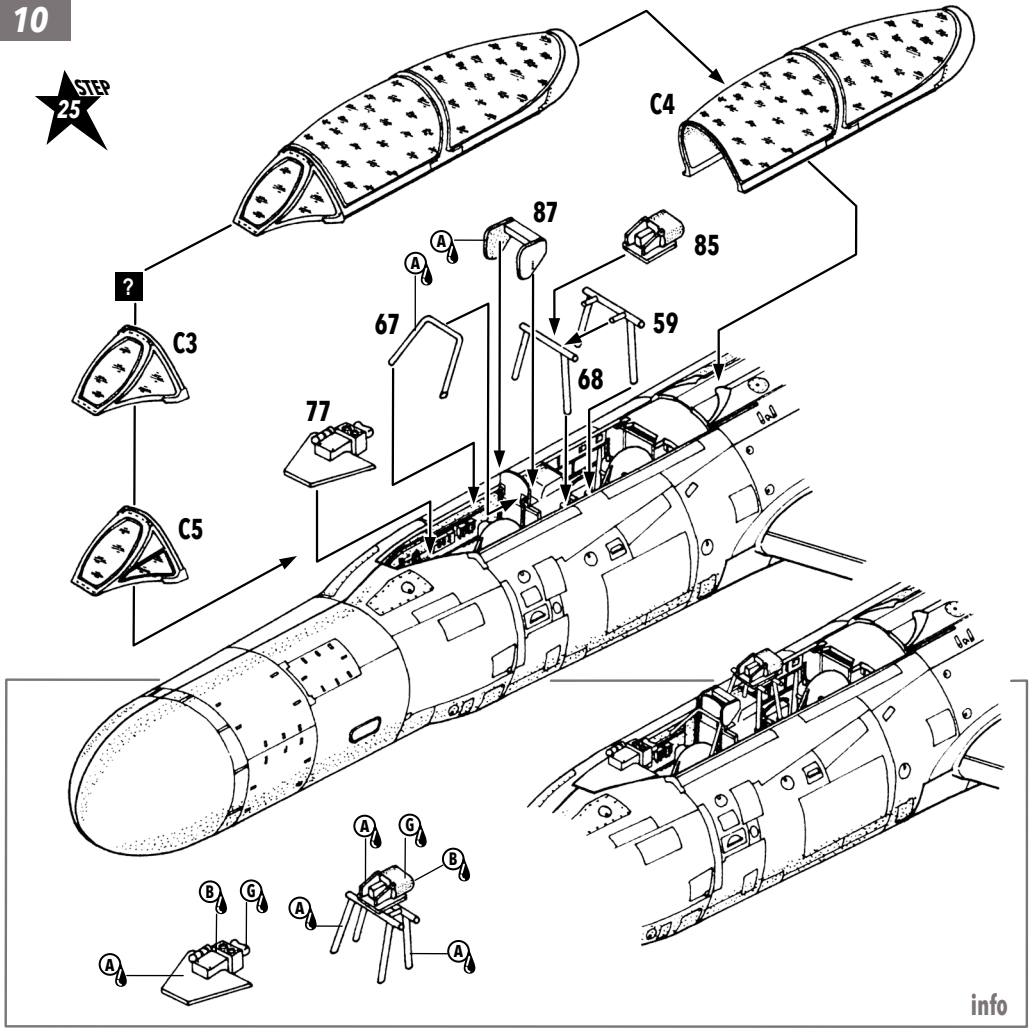

info

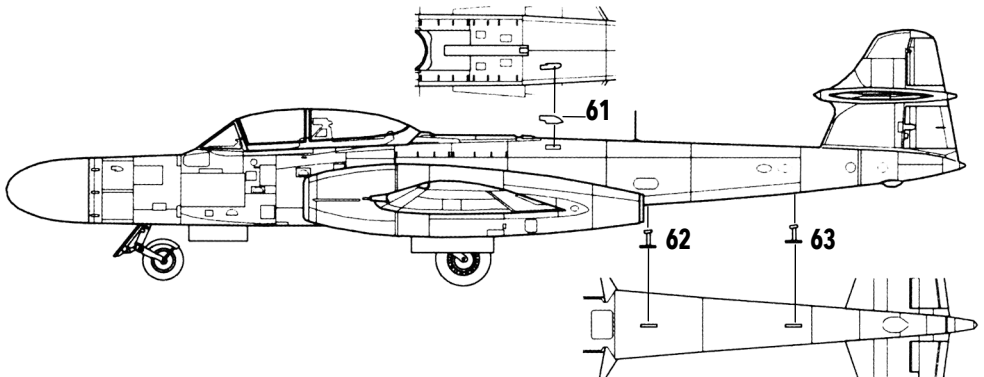

(Umístění popisek/Stencil Data)

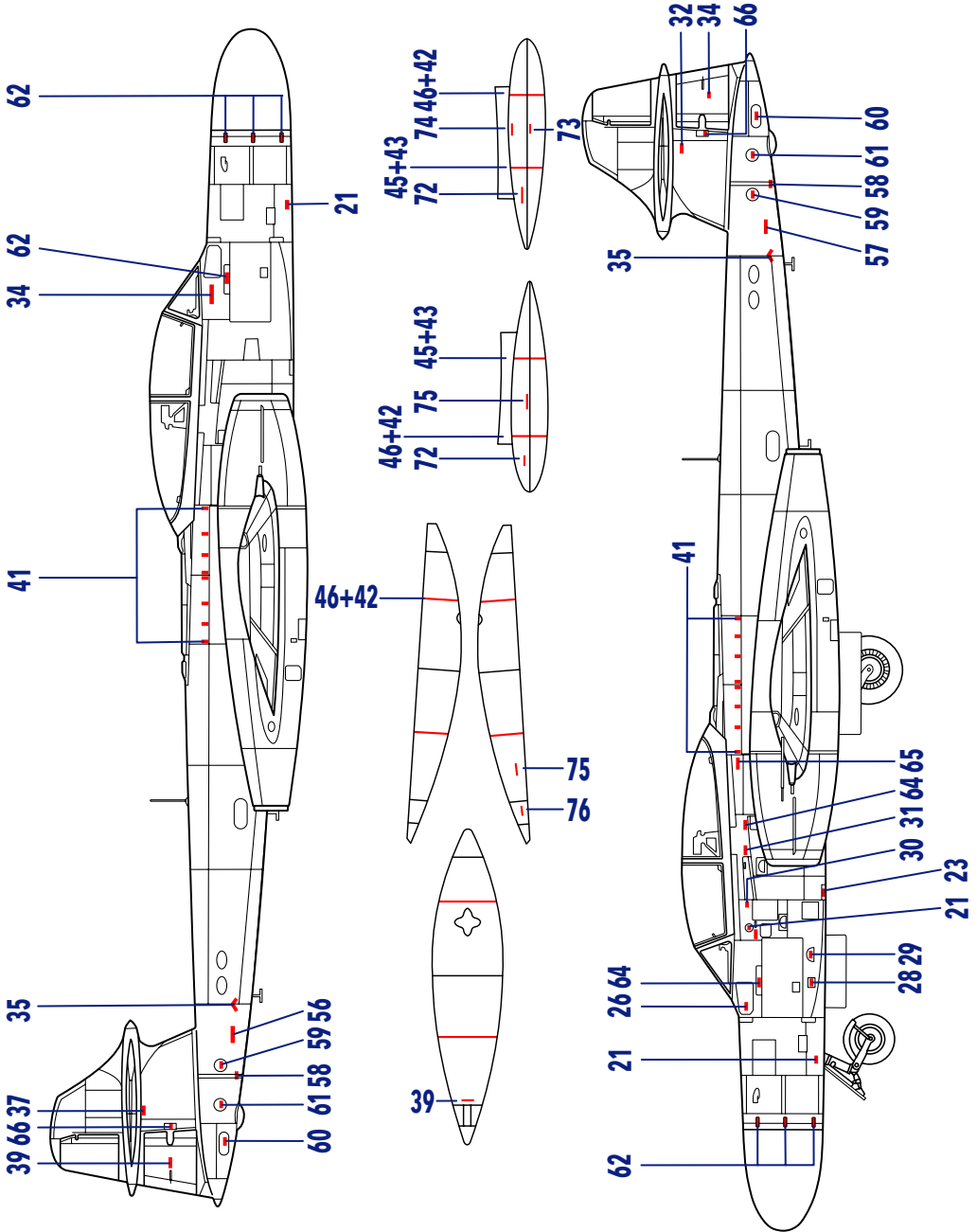

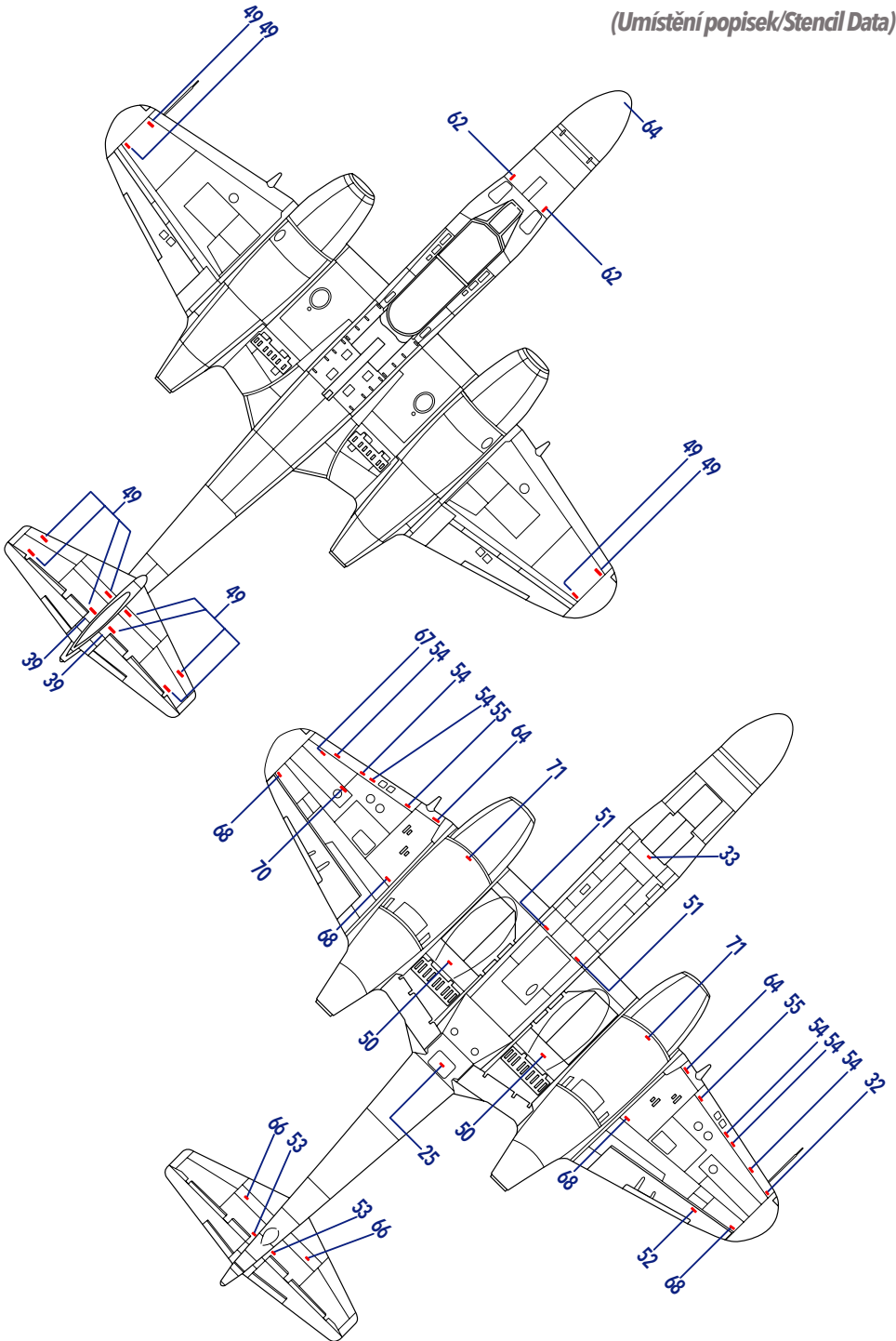

NF.14, WS 833 MS, 72 Sq. RAF, Church Fenton 1956, Wing Commander Maurice Shaw

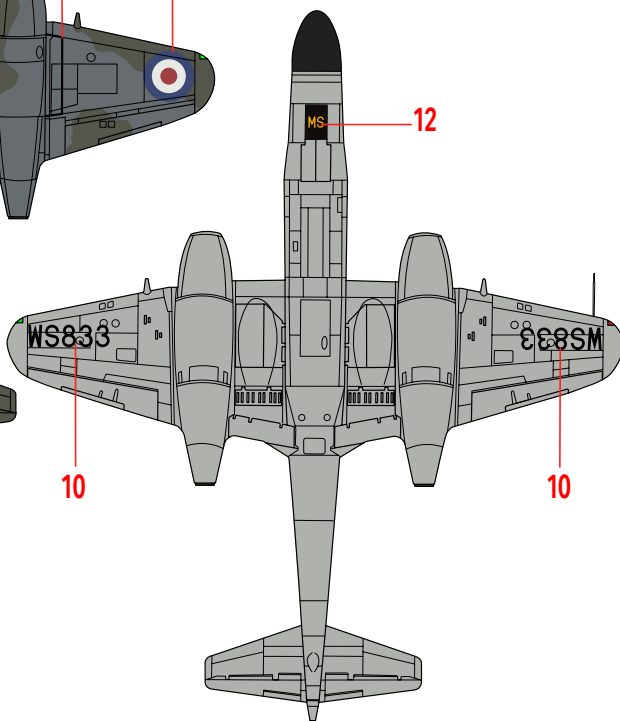
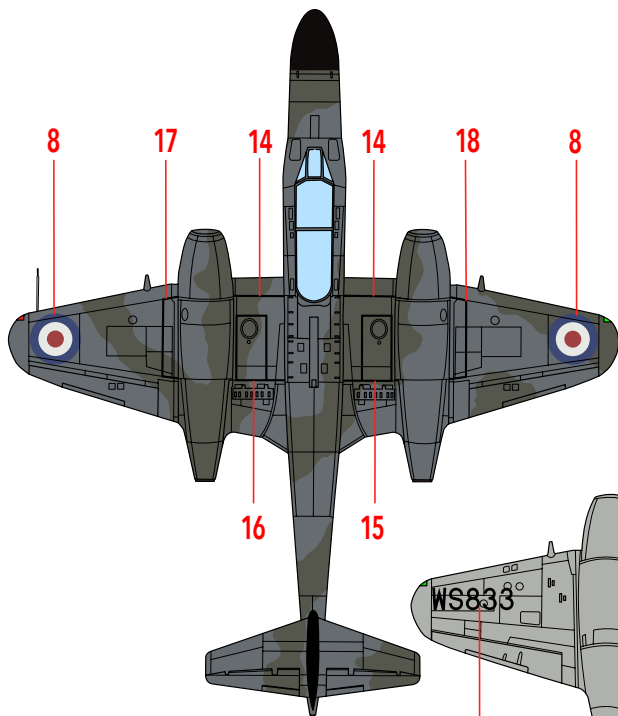
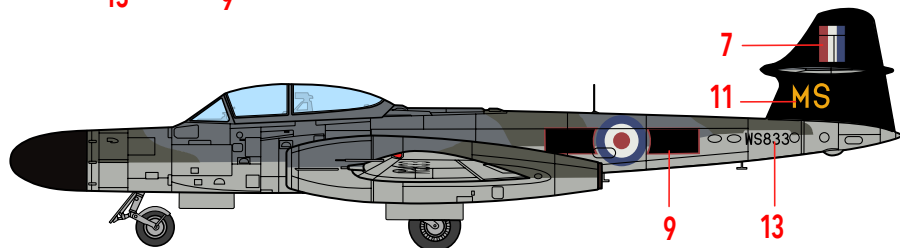
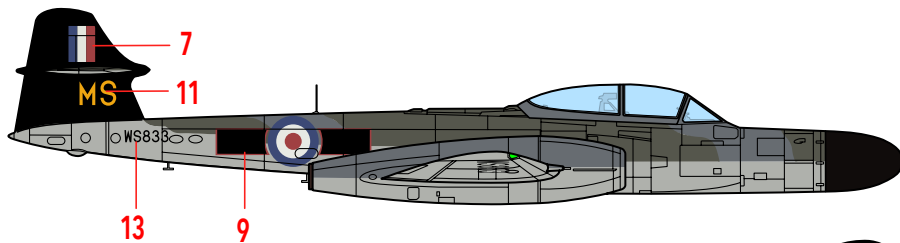

-  Gloss Black (FS17038)
-  Black Neoprene Rubber
-  Gloss Dark Green (BS 241)
-  Gloss Dark Sea Grey (BS 638)
-  Gloss Light Aircraft Grey (BS 627)

NF.14, WS 776 J, 85 Sq. RAF, Church Fenton 1958, S/Ldr Miroslav Lišlutín

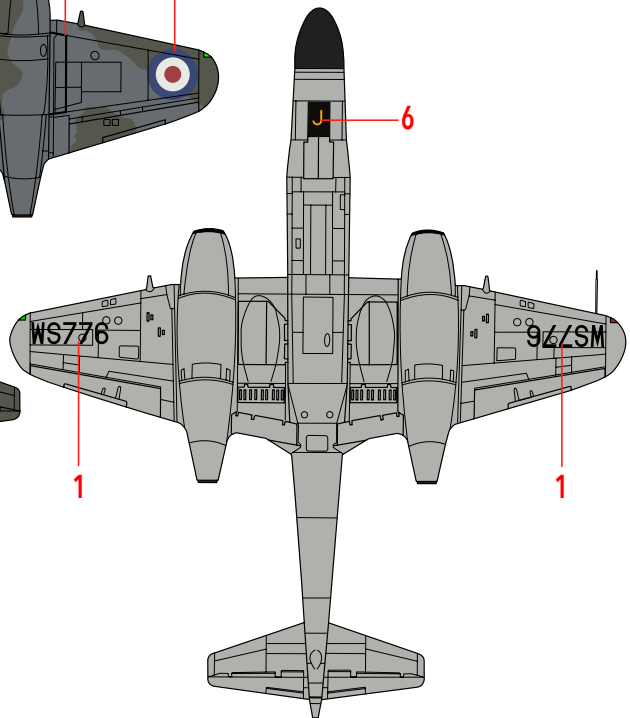
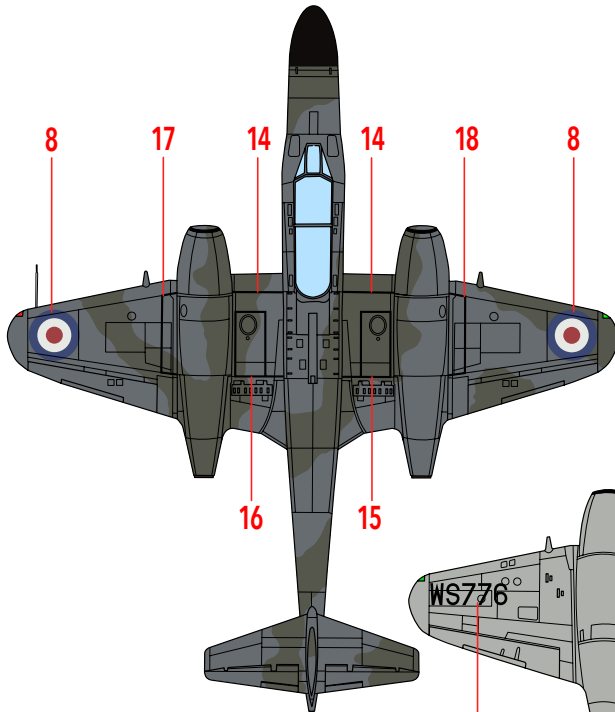
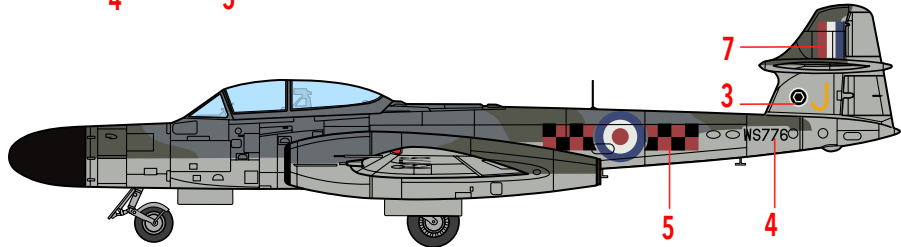
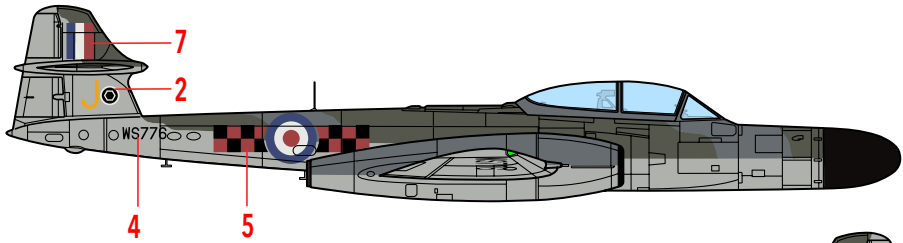

-  Gloss Black (FS17038)
-  Black Neoprene Rubber
-  Gloss Dark Green (BS 241)
-  Gloss Dark Sea Grey (BS 638)
-  Gloss Light Aircraft Grey (BS 627)