

unobtainium

Bentley Blower 4 ½ Litre wire-wheel upgrade set for Airfix 1/12th kit.

Thanks for purchasing unobtainium's long awaited Bentley Blower wire wheel upgrade set.



To assemble these wire wheels, you will need:

- Good quality side cutters (not your plastic best sprue cutters!)
- Good quality tweezers
- Razor saw
- Modelling knife
- Sanding board or sandpaper on flat surface
- Magnifier
- Ultra-thin CA

Familiarise yourself with the components, you should have 5 Rims and Jigs (combined as 1 part each) 5 hubs(combined on a single carrier), 4 knock offs (2 left, 2 right handed) and Valves (combined on a single disk) 3 rows of spoke nipple sets plus mild steel wire pack.

unobtainium

IMPORTANT – DO NOT remove the RIM from its base yet, this is the jig to build the wheel and is only removed after adding all the spokes as a final step.

Start by carefully removing all the printing supports from the hub - it should look like this, take note to remove the 4 alignment dowels that will locate with the Airfix kit Brake drum holes.



Ensure the rear face is flat, removing all print supports as necessary, but not the four pins above.

You will see that there is a keyway on rear of the hub, so align this with the key in the centre of the rim jig. This should be a snug fit and remain in place during construction - **DO NOT GLUE THIS**

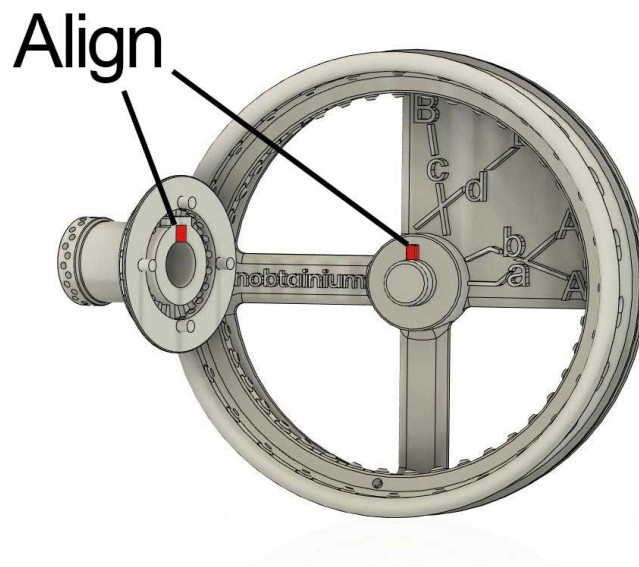

Next prepare the spokes, you will require 42 X 20mm lengths for the rear spokes **A-a** and **A-b**, and 28 X 25mm lengths for the front spokes **B-c** and **B-d** for each wheel.

unobtainium

It's a good idea to roll the wires between two flat boards to ensure they are straight after cutting.

Each spoke requires a bend on the hub end at 1mm as follows: - A-a 80°, A-b 60°, B-c 90°, B-d 90°
This angle is not critical, and you will see the angle each spoke should be bent to as you insert them.

The hub and rim holes are organised as follows, the hub is lowercase **a** through **d** starting at the back and the rim is Uppercase **A** through **B** starting at the back.

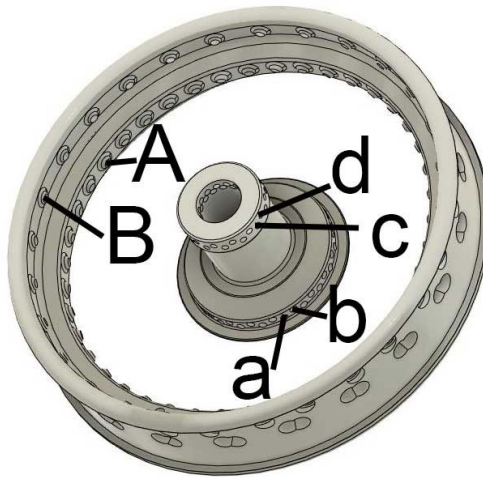

We are going to start with the **a-A** spokes, so locate this on the jig,

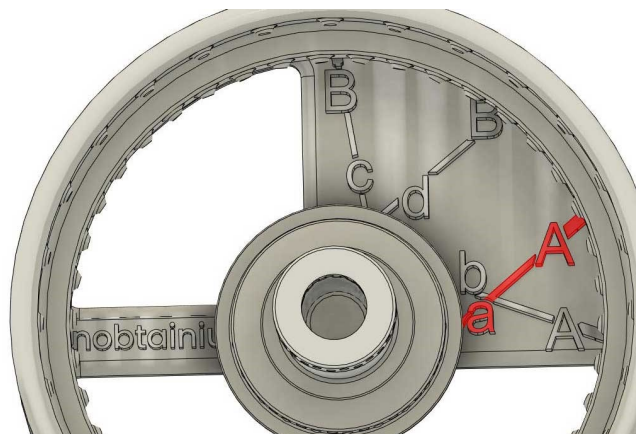

Using the **A-a** 20mm spokes you prepared earlier, from inside the rim, using the visual guide printed on the jig, thread into the first hole **A** on the rim, and the inner hole **a** on the hub. Secure the hub

unobtainium

end with a tiny amount of CA, ensuring you don't obstruct any other holes. Thin wire wrapped around a cocktail stick is a good way of applying a minute amount of ultra-thin CA to the joint.

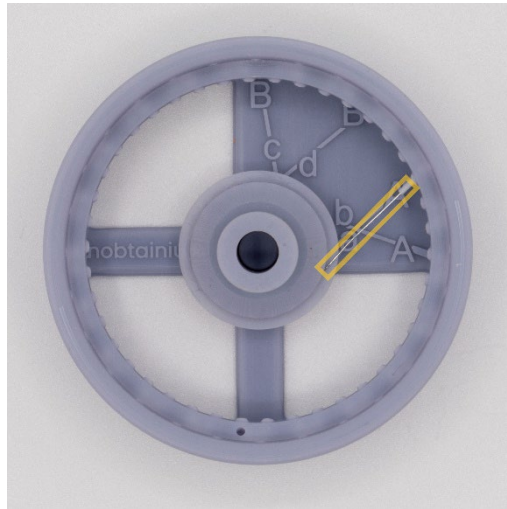

Take the first nipple and slide over the wire from outside the rim, do not use CA for this yet, it will stay in place without until the wheel is complete.

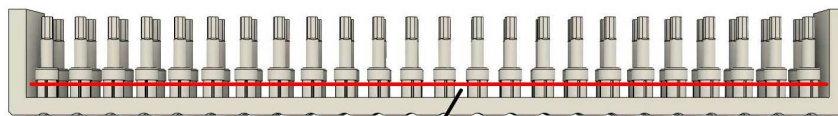

Cut here

For the next spoke, skip a hole on the Rim and use the next row a hole on the hub, like this:-

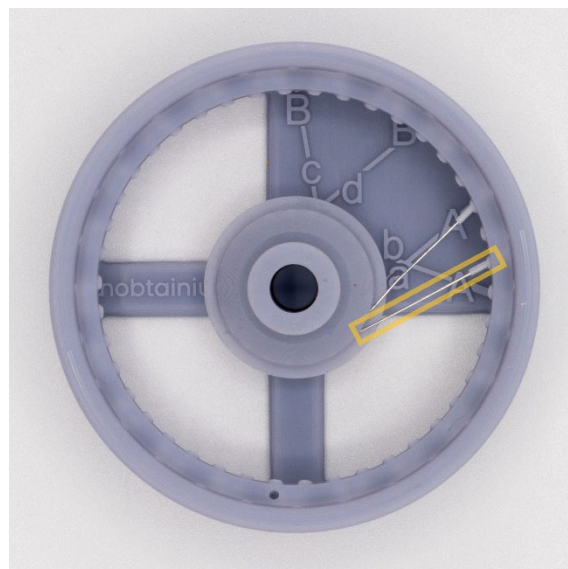

Take care as row **b** on the hub is slightly higher than row **a**, so make sure you pick the correct hole.

unobtainium



Continue until all 21 **A-a** spokes are in place.

Next, we will be lacing **A-b**, this is the back row of the rim and the remaining back row of the hub that you left every other hole empty in the last step.

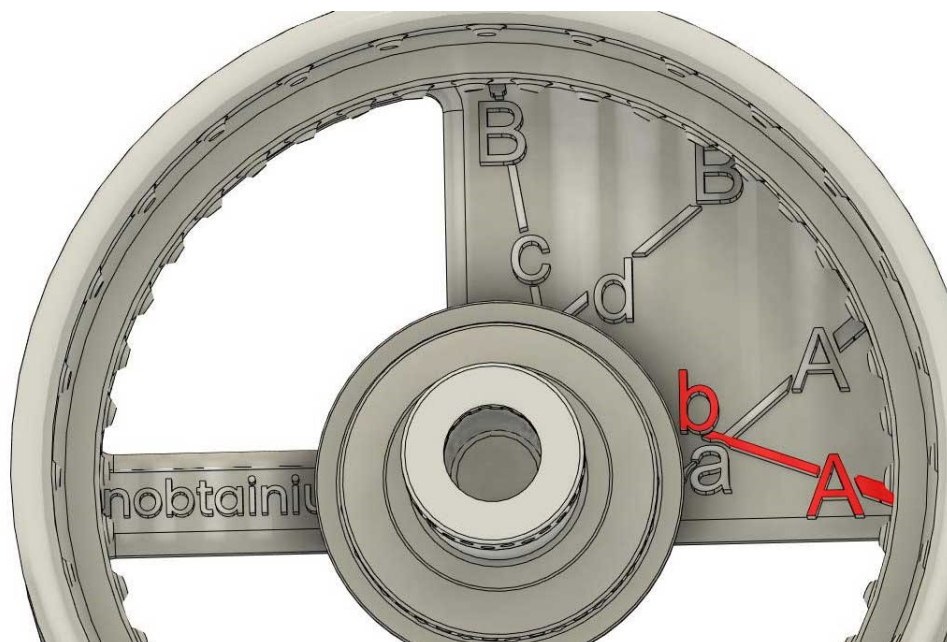

unobtainium

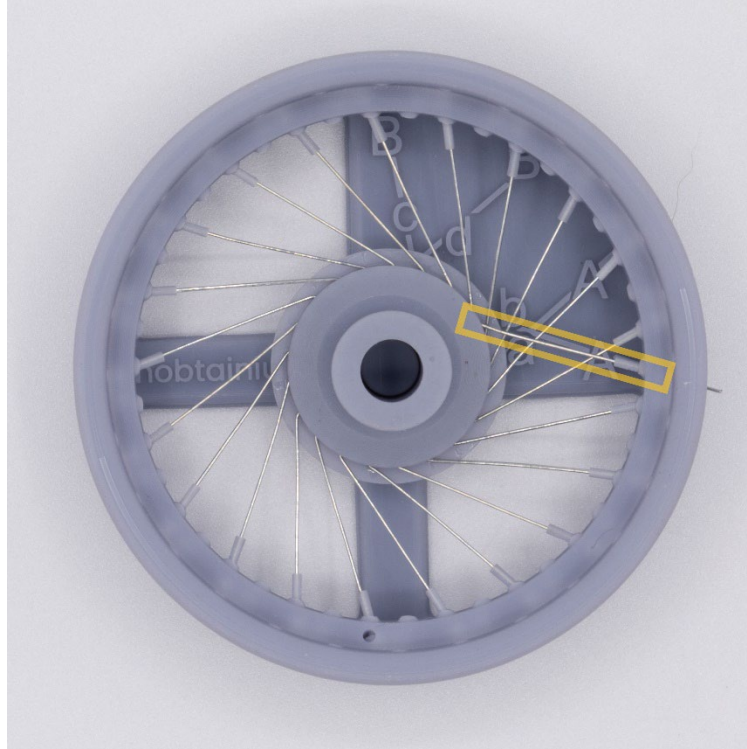

Continue as before, using CA on the Hub end only, inserting the nipples, but not fixing with CA yet. you should get to here



This completes the back row, **A-a**, **A-b** of the hub.

unobtainium

Next we will thread **B-c** using the guide on the jig, the **B-c** spokes prepared in stage 1 and the same techniques as before ie use every other hole on row **B** of the rim and all of row **c** on the hub, use CA on the hub end but not on the nipples yet.

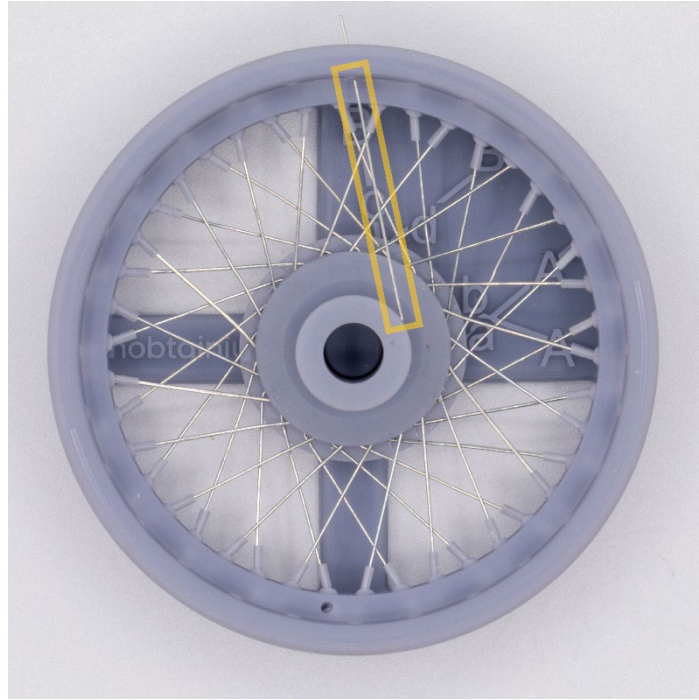

You should end up here



unobtainium

Finally thread spokes B-d using the now familiar technique

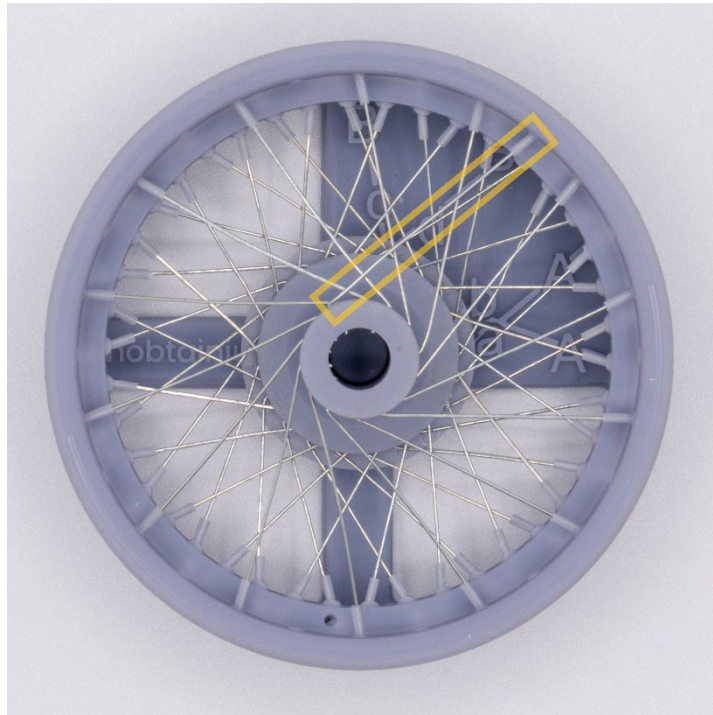

Repeat as earlier

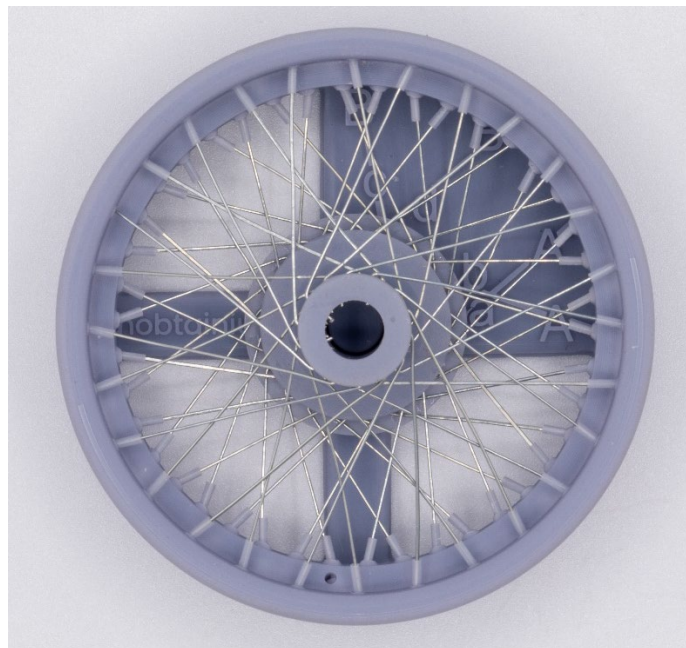

Ensure all the spokes are still straight and taught, correct as required. Then you can run CA around the nipples and spokes to lock the wheel off. Trim any excess wire protruding from the rim. Allow the CA to cure fully before the next step.

unobtainium

It's now time to release the wheel from the jig. Take care to handle the wheel by the rim and do not bend or compress the spokes. Carefully saw through the support tabs marked in red from the rear of the rim, cut as close to the jig (as opposed to the wheel rim) as possible, leaving the stubs on the wheel rim to avoid damage.

Cut
Here

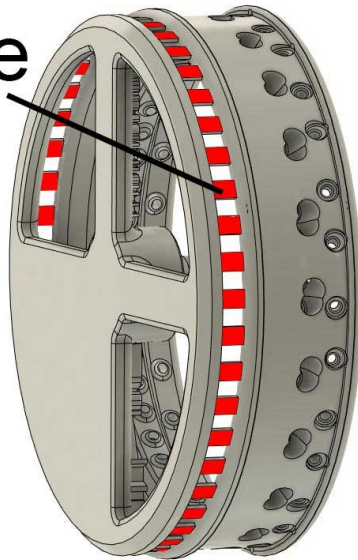

DO NOT SAW THROUGH THE CENTRE HUB AREA!



unobtainium

The stubs you are left with on the rim can be sanded away very easily.

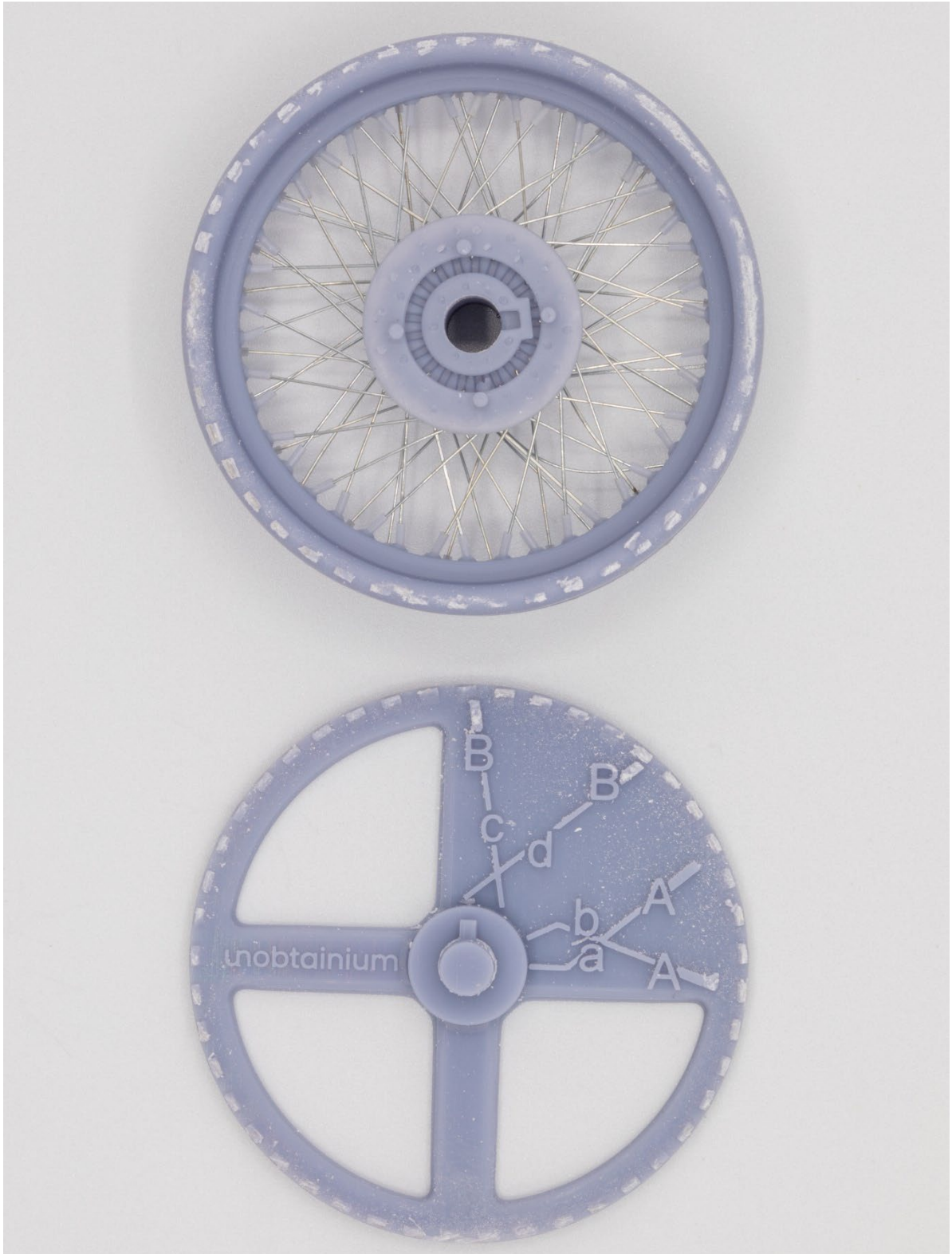

unobtainium

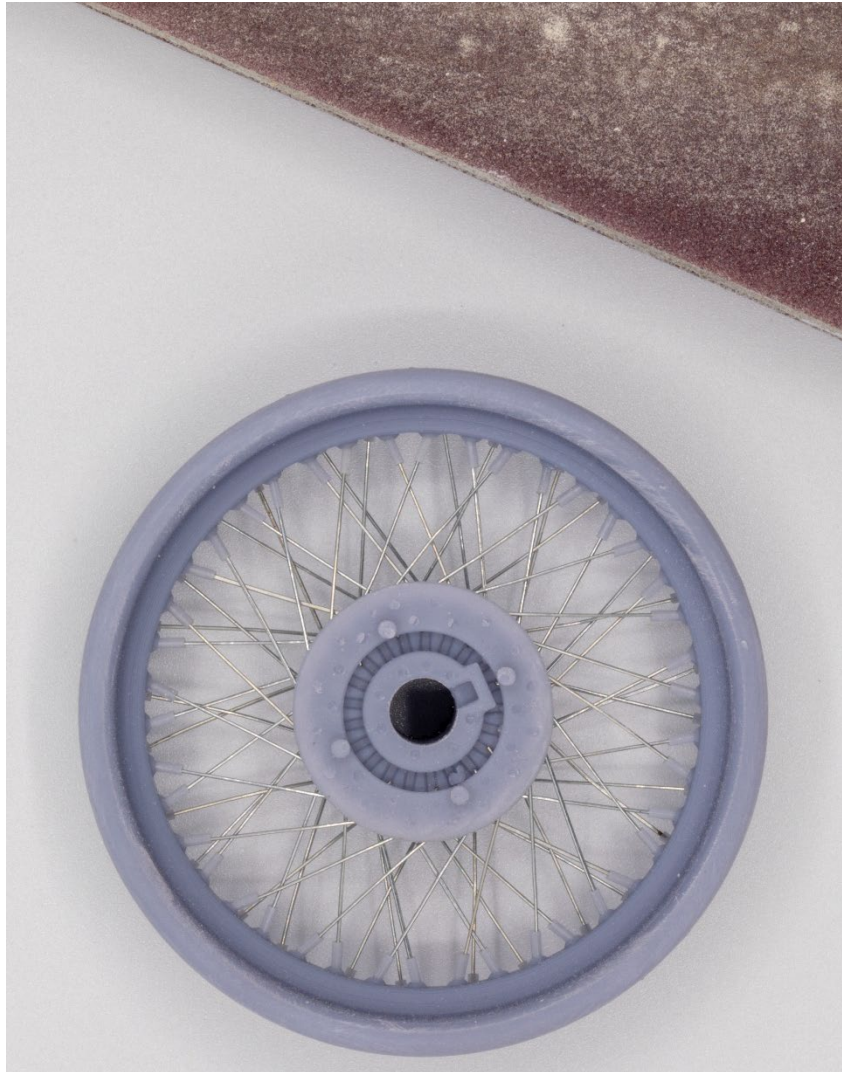

Finally sand the rear face smooth

You've got four more to make now - enjoy 😊

You may need to clear the hole in the hub centre with a round file if some of your spokes over-extend into it.
centre knock offs and tyre valves are also included in the set, there is a pre-printed hole in the rim for the valve, so don't drill another one!

I recommend priming with Tamiya fine surface primer or similar with at least two very fine coats.
Paint the colour of your choice, with very thinned, multiple coats to preserve the detail