

LOCKHEED-VEGA PV-1 VENTURA

Boulton Paul turret, glassed nose and RAF roundels for this version are available in a later re-release of this kit.

RAF Ventura II, AE936 SB-G 464 (RAAF)
 Squadron, Methwold, Norfolk



INSIDE RIGHT FIN
 INSIDE LEFT FIN



U.S. NAVY PV-1 "MISS-US-FLAK". VB 142, BuNo 49486, Tarawa, 1944.



NOSE DETAIL

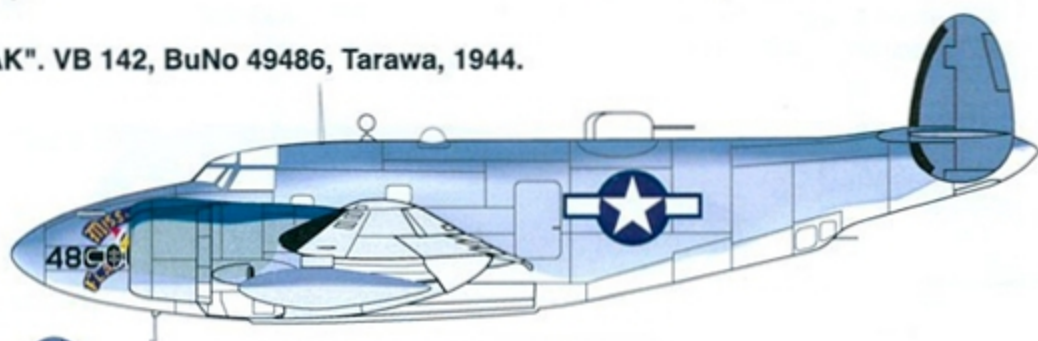

USE NATIONAL INSIGNIA FROM THE KIT



XTRACOLOR AND XTRACRYLIX COLOURS

-  X001 DARK GREEN BS 241
-  X002 DARK EARTH BS 450
-  X007 SKY BS 210
-  X121 SEA BLUE FS 35042
-  X107 BLUE GREY FS 35189
-  X007 FS 36373 LIGHT GREY

Visit our website for more decal titles.
www.hannants.co.uk

U.S. NAVY PV-1 "THUMPER". VB 132, Port Lyutey, French Morocco, 1944.

Insignia and codes are in the same position on both sides.

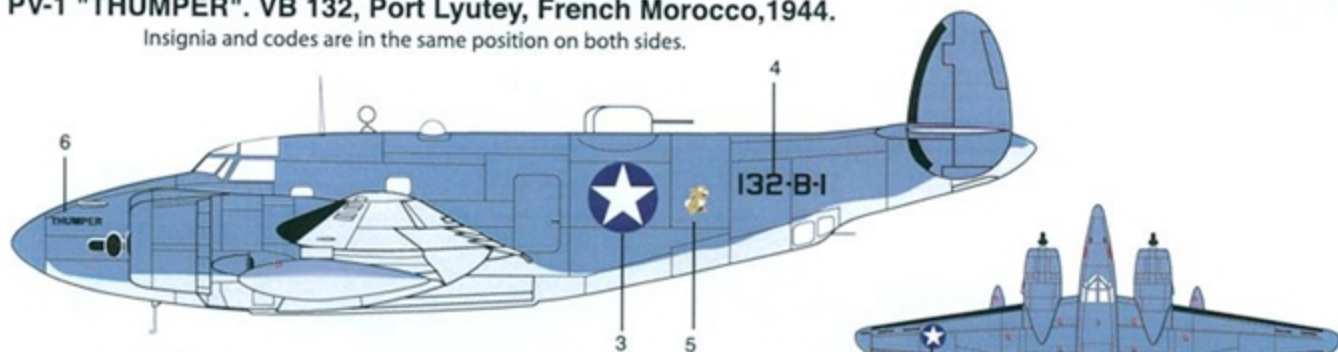

ROYAL NEW ZEALAND PV-1 NZ4509, NO. 11 SU, Gisborne, NZ, 1944

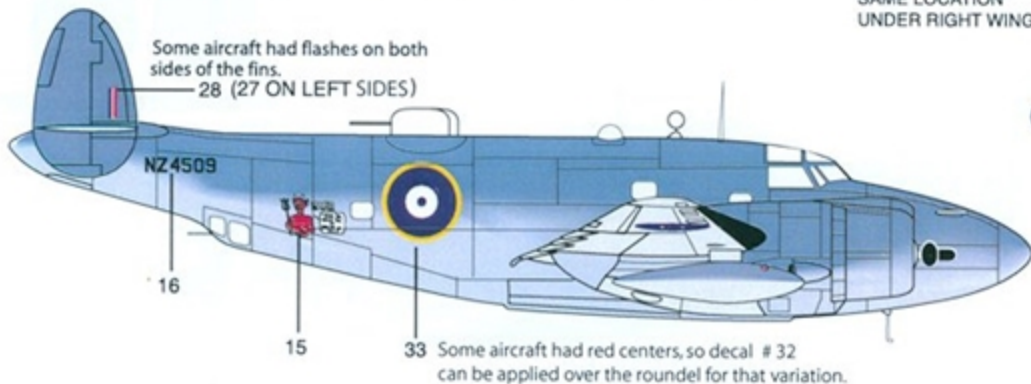

Some aircraft had flashes on both sides of the fins.
28 (27 ON LEFT SIDES)

Some aircraft had red centers, so decal # 32 can be applied over the roundel for that variation.

NOTE: THE DE-ICER BOOTS WERE SOON REMOVED FROM RNZAF VENTURAS, AS THEY WERE NOT USUALLY REQUIRED IN THE TROPICS.

"Slippery Sam" RNZAF PV-1 NZ4511, 1(BR) Squadron, Henderson Field, 1943.

Insignia and codes are in the same position on both sides.
(U.S. style bars, decal 34, were added in the war zone*)

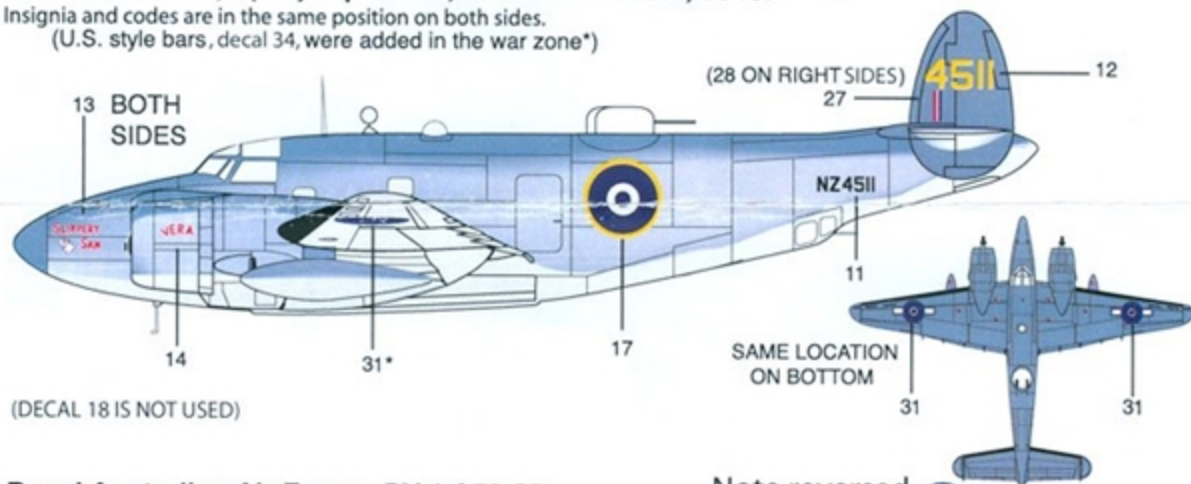

(DECAL 18 IS NOT USED)

(28 ON RIGHT SIDES)
27

SAME LOCATION ON BOTTOM

"Reluctant Dragon" Royal Australian Air Force, PV-1 A59-85, 13 Squadron RAAF, 1944.



NOSE DETAIL

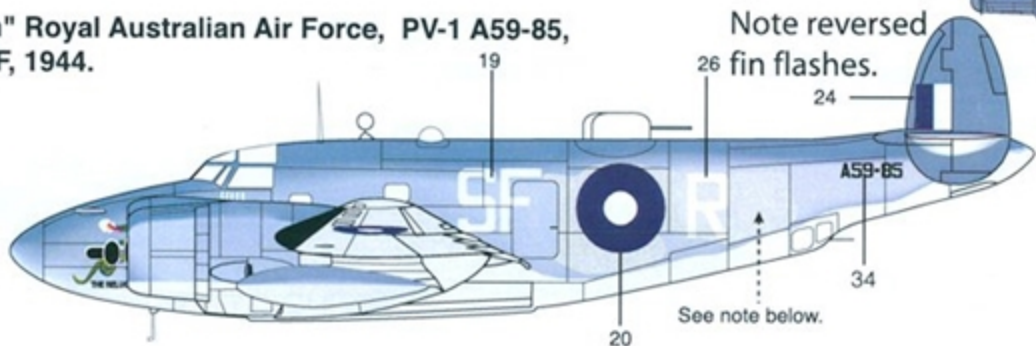

Note reversed fin flashes.

See note below.

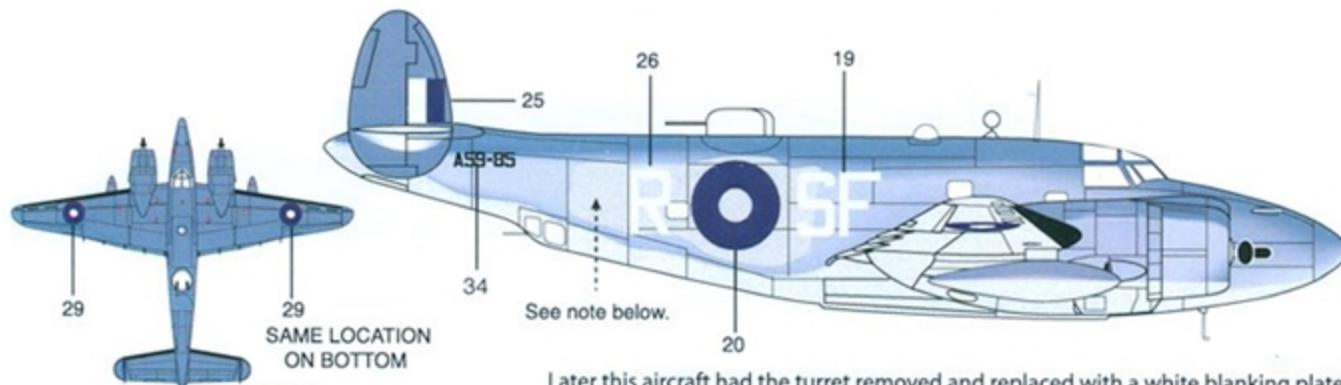

SAME LOCATION ON BOTTOM

NOTE

The original codes were painted out.
To approximate this color,
mix 20% X150 with 80% white.

Later this aircraft had the turret removed and replaced with a white blanking plate at which time the code R had a black outline, decal 35.

Decals 34 are provided so that bars can be added to other roundels if required.