

**92138, 92140**

Late in 1933 the RLM issued a specification calling for a monoplane fighter design. Four designs were produced: Arado 80, the Fw 159, the Bf 109 and the Heinkel 112.

The He 112, which was designed by Dipl. Ing. Heinrich Hertel, completed with the other three at a competition held at a competition held at Travemünde in October 1935. The product of the He 112A series was failed and Hertel undertook a complete structural redesign of the aircraft under the designation He 112B. The first production prototype was the V9, which first flew in July 1937. The Japanese government placed an order for thirty He 112 during the autumn of 1937. The He 112B-0 had two 20 mm cannon in the wings and two 7,9 mm MG machine-guns mounted above the engine cowling. The first twelve aircraft were delivered to Japan during the spring of 1938, but a second batch of twelve, were hurriedly impressed into the Luftwaffe because of the Sudeten crisis.

The machines were delivered to III./JG 132 at Fürstenwalde, but following the signing of the Munich agreement, the fighters were returned to Heinkel for export and immediately offered the to Spain. The seventeen were delivered to grupo 5-G-5 in November 1938. When the Spanish civil War was ended, the fifteen He 112 B-0 were transferred to Spanish Maroco.

Royal Rumanian airforce ordered early 1939 twentyfour aircraft of the improved B-1 series. The B-1 series was powered by a 700 hp Jumo 210 G engine with direct fuel injection. Twelve aircraft were delivered to each of two unic, the 20th Squadron, engaged in the defence of Bucharest, and the 51th, supported the Rumanian army across Bessarabia from June 1941. By the middle of 1942, remaining He 112 had been relegated to training units.

The last airarm to receive the He 112 was the Royal Hungarian Air Force which purchased thry He 112 B-1.

*Specifications:*

Span - 9,1m

Lenght - 9,3m

Engine - Jumo 210C (B-0)

- Jumo 210E (B-1)

Weight empty - 1 617 kg

Weight full - 2 248 kg

Max. speed - 510 km/h

Range - 1 150 km

Ceiling - 9 500m



Díly  
Parts  
Teile

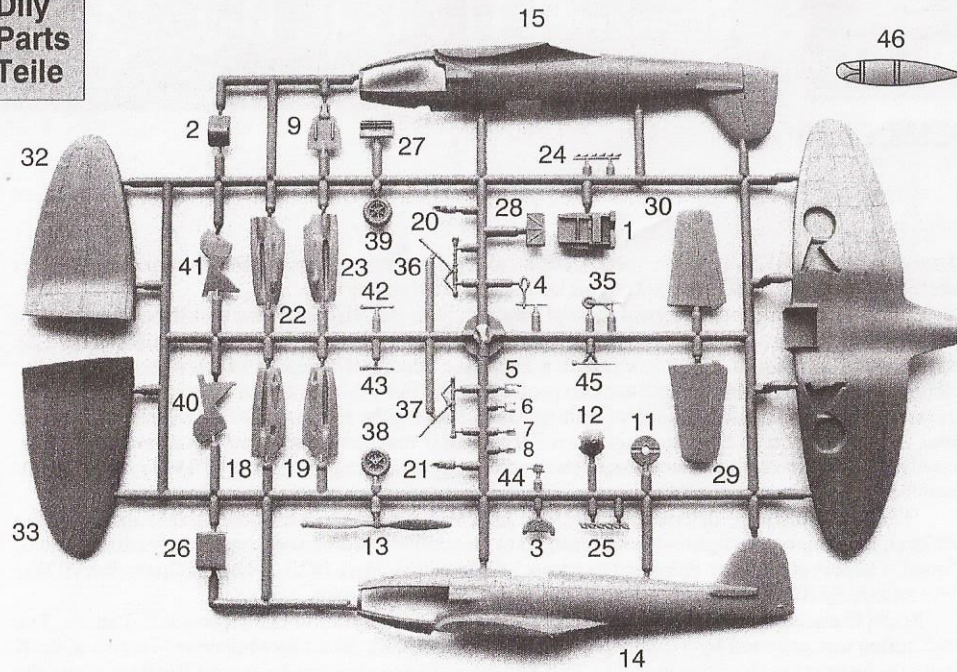

1.

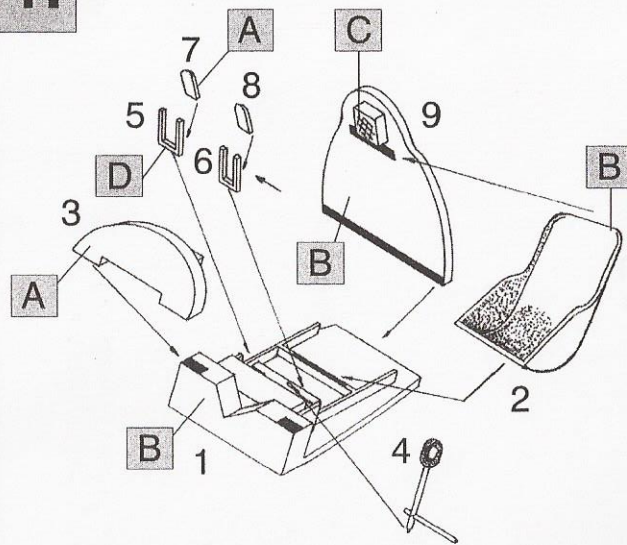

Barvy H - Humbrol  
Colours Ag - Agama

A	Černá Black Schwarz	H33 Ag 07 FS 37038
B	Šedá Grey Grau	H126 Ag A23 FS 26270
C	Hnědá Brown Braun	H29 Ag B2 FS 33105
D	Stříbrná Silver Silber	H111 Ag 08Me FS 17178
E	Výfuky Exhaus Tubs Auspuff	H rust Ag 54
F	Tmavá šedá Dark Grey Dunkelgrau	H32 Ag A17 FS 36081

2.

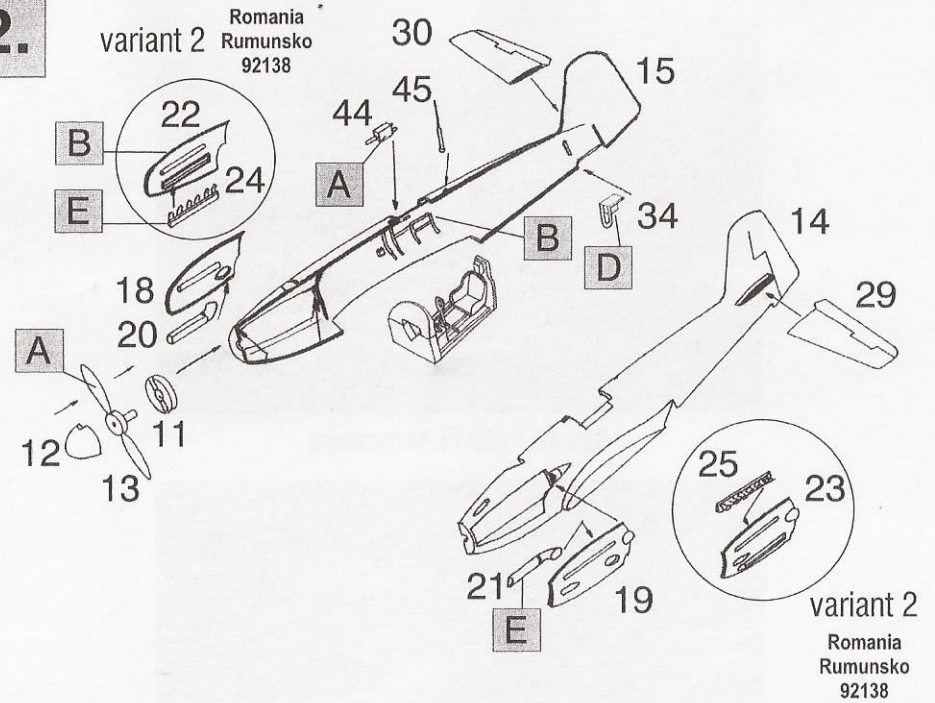

3.

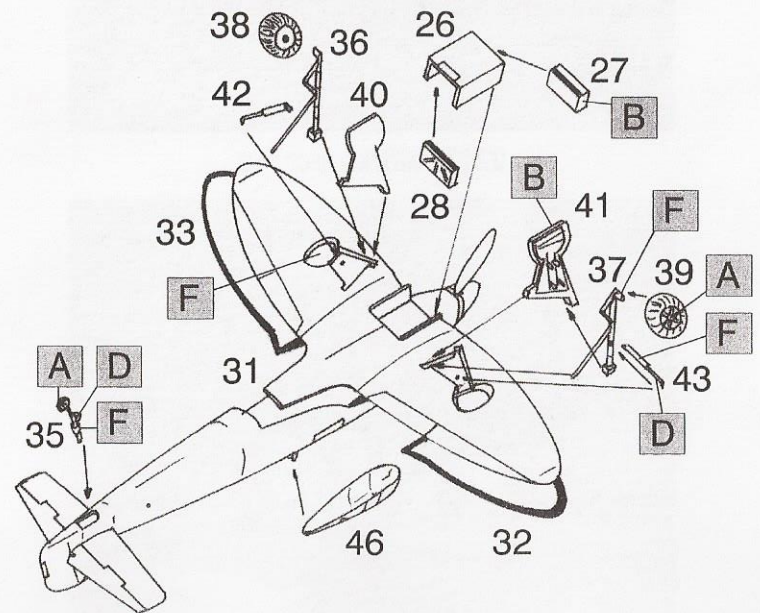



① Heinkel 112 B-0, Cap. Miguel Entrena Klett, Spanish AF 1943  
(shot down P-38 March 1943)

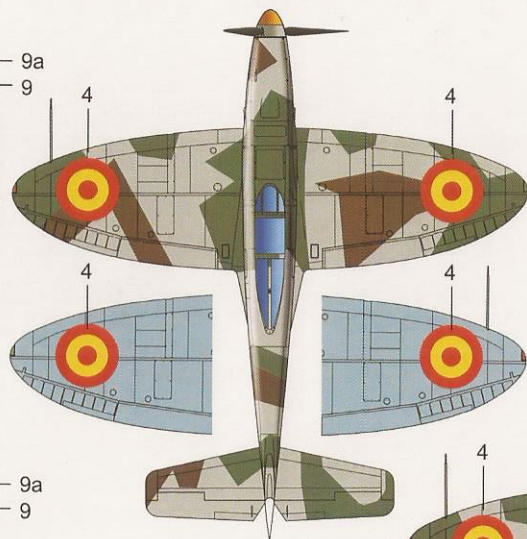
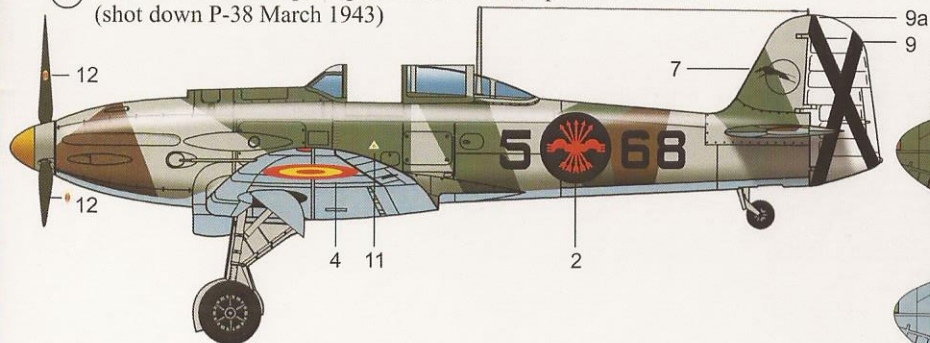

-  Tmavě hnědá / Dark brown - RLM 61
-  Tmavě zelená / Dark green - RLM 62
-  Světle modrá / Light blue - RLM 65
-  Žlutá / Yellow
-  Šedo zelená / Grey green RLM 63
-  Červená / Red
-  Bílá / White

② Heinkel 112 B-0, Spanish AF, 2 Rg. Mixte, Spain June 1946

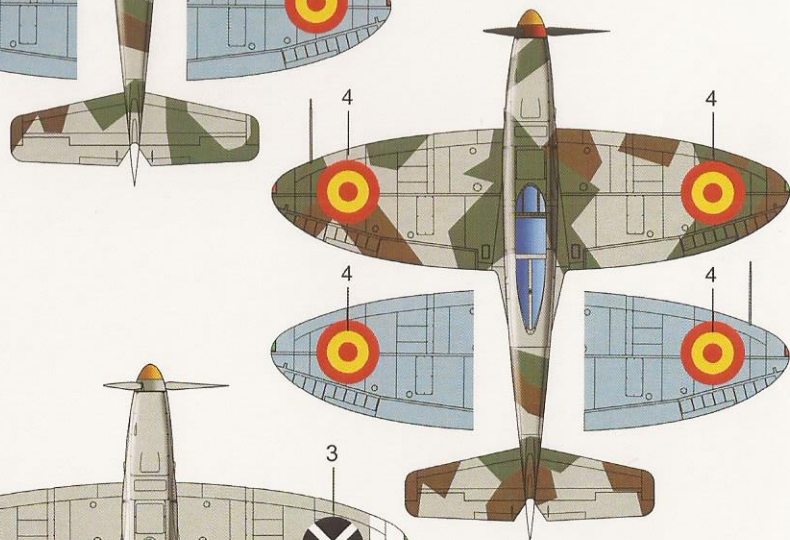
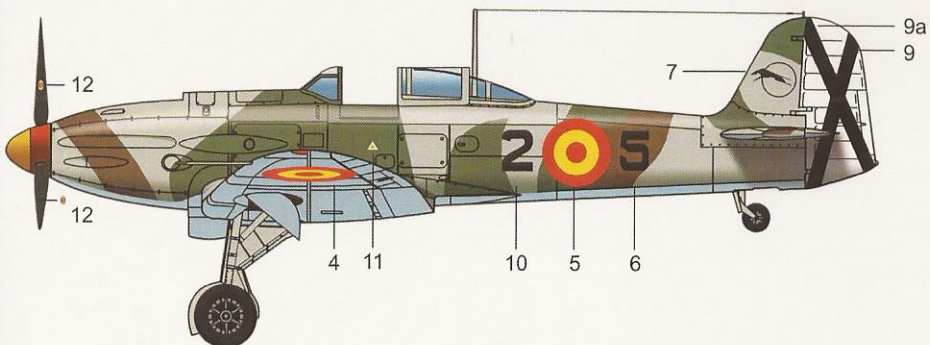

③ Heinkel 112 B-0, Cp. Miguel Garcia Pardo,  
(shot down Polikarpov I-16 at January 1939)

