

RUSSIAN WWII FIGHTER 1:48 SCALE PLASTIC KIT



ProfiPACK



eduard

intro

One of the most popular and best known Russian aircraft ever built was born in 1933. On the last day of that year, on December 31, the famous Soviet aviator Valerij Tchaloov conducted the maiden flight of the new CKB-12 prototype. The CKB-12 was a very modern and revolutionary design at the time. The installed powerplant was a Shvetsov M-22 engine (a license built Bristol Jupiter) rated at 480 hp, instead of the anticipated Shvetsov M-25 engine giving 750 hp. That was a Soviet license built Wright R-1820 Cyclone. Although the new aircraft was a bit underpowered, Tchaloov was amazed with its flight capabilities and especially its sensitivity of control. The second prototype was outfitted with an imported original Wright Cyclone engine, and the aircraft performance greatly improved. After necessary development and improvements, serial production was ordered at Zavod 39 in Moscow and at Zavod 21 in Gorki under the VVS (Soviet Air Force) designation I-16. These aircraft were equipped with the M-22 engine, because the new M-25 powerplant was not yet available, and no weapons were installed. Maximum speed of these first I-16s was 362 km/h at sea level and 346 km/h at 3000 m. Fifty aircraft were manufactured at Zavod 39, known as I-16 without any additional suffix designation. Zavod 21 produced the first batch of I-16, though with some difficulties, because three other aircraft types were on their production lines. For this reason, Zavod 21's I-16 were suffixed as „Type 4“. In late summer, 1934, the first aircraft reached VVS units. Reception of the new aircraft was cool, to put it gently. The flight characteristics were very different from the operational biplanes then in service; control was overly sensitive, and the landing speed too high with a lack of frontal view due to the wide nose. The lack of landing flaps, compensated for by the downward deflection of the ailerons acting as flaps on landing, didn't made the landing any easier. Accident rates soared to unacceptable levels, and reached the point where units couldn't achieve operational status. At this time, five NII VVS (Air force research institute) pilots, Kokkinaki, Suprun, Preman, Evseev and Shevchenko, made a tour of air force bases. With their red painted I-16, they demonstrated the aircraft's performance and potential. In late Spring, 1935, M-25 engine was finally available in sufficient quantities. The new engine received a new Watter type cowling, giving the I-16 its characteristic shape. The flight characteristics were unchanged, but the performance significantly improved. The maximum speed was now 390 km/h at sea level, and 445 km/h at 3 000m. The aircraft was now armed with two 7,62 mm ShKAS machine guns mounted in the wings. By January 1936, the Type 5 replaced the Type 4 on the production lines at Zavod 21. Still a fresh newcomer on the fighter scene, the I-16 Type 5 soon got the chance to show their stuff in a real fight. During the Spanish Civil War, the I-16 built its great warrior reputation. Until 1938, the Type 5 remained as the main version, marginally updated to the Type 6, but it is not certain if this was an official designation. Besides Spain, the Type 5 saw combat over China, where these aircraft were sent along with Soviet crews. By 1937, initial troubles were forgotten, but new critics were found. Therefore, the new and improved Type 10 was introduced, instigating some significant changes. First, the new M-25V 750 hp engine was installed. The wing was re-designed to include landing flaps. Two 7,62 mm ShKAS machine guns were added on top of the engine, with two corresponding fairings on the engine cowling. The cockpit was improved, and the canopy was completely redesigned, with an all-glass single piece windscreen ahead of a now open cockpit. Maximum speed was 390 km/h at sea level and 438 km/h at 3200 m. The Type 10's production started at Gorki in March, 1938. The Type 10 reached Spain as well as China, and fought against the Japanese over Chalkin-Gol and Chasan Lake. They saw action in the Winter War against the Finns, and also fought in Poland in the Autumn of 1939. In June, 1941, when the USSR was attacked by Germany and the Great Patriotic began, the I-16 Type 10 remained, along with other I-16 versions, the main weapon of VVS fighter units.

In total some 9450 I-16s of all versions were produced, most of them, to the tune of 8495, by Zavod 21 at Gorki. Type 10 was followed by improved versions, Type 17, 24 and 29.

The first I-16s, the Types 5 and 6, appeared in Spanish skies in November 1936. Republican government bought 422 I-16s from Soviet Union, but only about 293 aircraft was delivered to the Spanish hands due to the various issues. The I-16s experienced their baptism of fire on the 13 November 1936, when 12 I-16s (Type 5 and Type 6) intercepted a Nationalist bombing raid on Madrid. The I-16s immediately began dominating the enemy He 51s, Arado Ar 68 and Fiat CR.32 biplanes until the arrival of the Messerschmitt Bf 109.

Combat experience showed the I-16's weaknesses also; several aircraft were lost after structural failure of the wings, machine gun bullets could sometimes penetrate the armored backrest and fuel tanks protection. The Mediterranean climate required more efficient oil radiators. The dust shortened the life of the engines. The inadequate light armament of only two 7.62 mm (0.30 in) machine guns (three ones in the Type 6 case) insufficient in combat with modern bombers led to the arrival of the four-gun Type 10. The total number of I-16s delivered to Spain in 1936-1938 amounted to 276. By the war end on 1 April 1939 the total of 187 Ratas was lost in Spain: 112 in the aerial combat, one shot down by anti-aircraft fire, 11 destroyed on the ground, one force-landed and 62 lost in accidents.

After the Nationalist's victory 22 captured Ratas were assigned to Grupo 28. Their number had increased to 52 later. The first 22 captured I-16s acted as Grupo 1W, then the designation of group changed to Grupo 28 de Caza (Fighter Group). The group was based at air station, San-Juan on the island

of Majorca. By the autumn of 1940 all the I-16s had been transferred to Sevilla where they joined Grupo 26.

In 1945 the Spanish Air Force introduced the new system of designation. Ratas then received a code C.8 instead of 1W. The national insignia - Red / Yellow cocardes were added to the sides of the fuselage. At about this time, Grupo 26 was renamed to Grupo 22.

In the early 1950's, the surviving I-16s were used at a fighter school in Morón. On August 15th, 1953, Miguel Entrena flew the last serviceable I-16 for the last time and terminated the interesting career of the "Rata" in the Spanish sky.

ATTENTION



UPOZORNĚNÍ



ACHTUNG



ATTENTION



注意



Carefully read instruction sheet before assembling. When you use glue or paint, do not use near open flame and use in well ventilated room. Keep out of reach of small children. Children must not be allowed to suck any part, or pull vinyl bag over the head.



Před započatím stavby si pečlivě prostudujte stavební návod. Při používání barev a lepidel pracujte v dobře větrané místnosti. Lepidla ani barvy nepoužívejte v blízkosti otevřeného ohně. Model není určen malým dětem, mohlo by dojít k požití drobných dílů.

INSTRUCTION SIGNS * INSTR. SYMBOL * INSTRUKTION SINNBILDEN * SYMBOLES * 記号の説明

OPTIONAL
VOLBABEND
OHNOUTOPEN HOLE
VYVRTAT OTVORSYMETRICAL ASSEMBLY
SYMETRICKÁ MONTÁŽNOTCH
ZÁREZREMOVE
ODŘÍZNOUTAPPLY EDUARD MASK
AND PAINT
POUŽIT EDUARDS MASK
NABARVIT

PARTS



DÍLY



TEILE



PIÈCES



部品

PLASTIC PARTS

A>

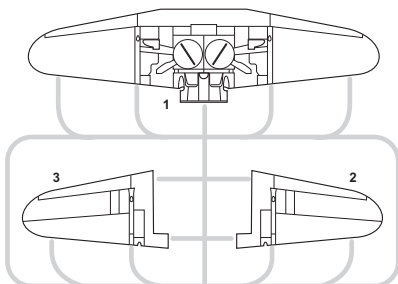

D> E>

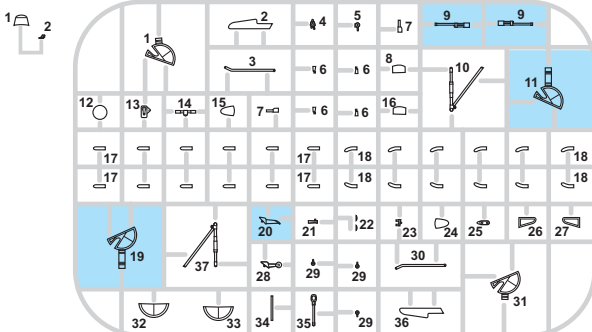
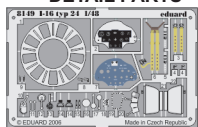
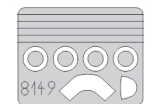
PE - PHOTO ETCHED
DETAIL PARTSeduard
MASK

FILM



F>

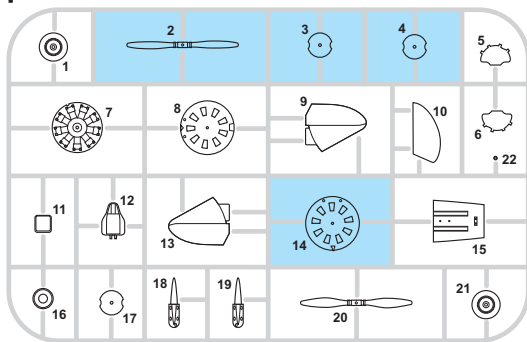

I>

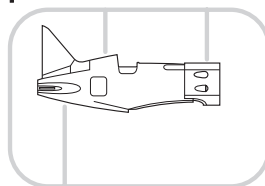

J>

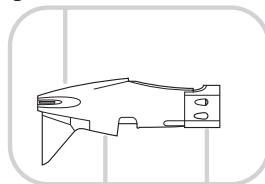

-Parts not for use. -Teile werden nicht verwendet. -Pièces à ne pas utiliser. -Tyto díly nepoužívejte při stavbě. - 使用しない部品

COLOURS



BARVY



FARBEN



PEINTURE



色

GSI Creos (GUNZE)		
AQUEOUS	Mr.COLOR	
[H 3]	[3]	RED
[H 4]	[4]	YELLOW
[H 12]	[33]	FLAT BLACK
[H 47]	[41]	RED BROWN
[H 57]	[73]	GRAY
[H 61]	[35]	LIGHT GRAY
[H 67]	[115]	LIGHT BLUE
[H 77]	[137]	TIRE BLACK
[H 90]	[47]	CLEAR RED

AQUEOUS	Mr.COLOR	
[H 94]	[138]	CLEAR GREEN
[H 303]	[303]	GREEN
[H 320]	[320]	GREEN
[H 35]	[81]	RUSSET
[]	[74]	LIGHT BLUE
Mr.METAL COLOR		
[MC214]		DARK IRON
[MC218]		ALUMINIUM
Mr.COLOR SUPER METALLIC		
[SM06]		CHROME SILVER

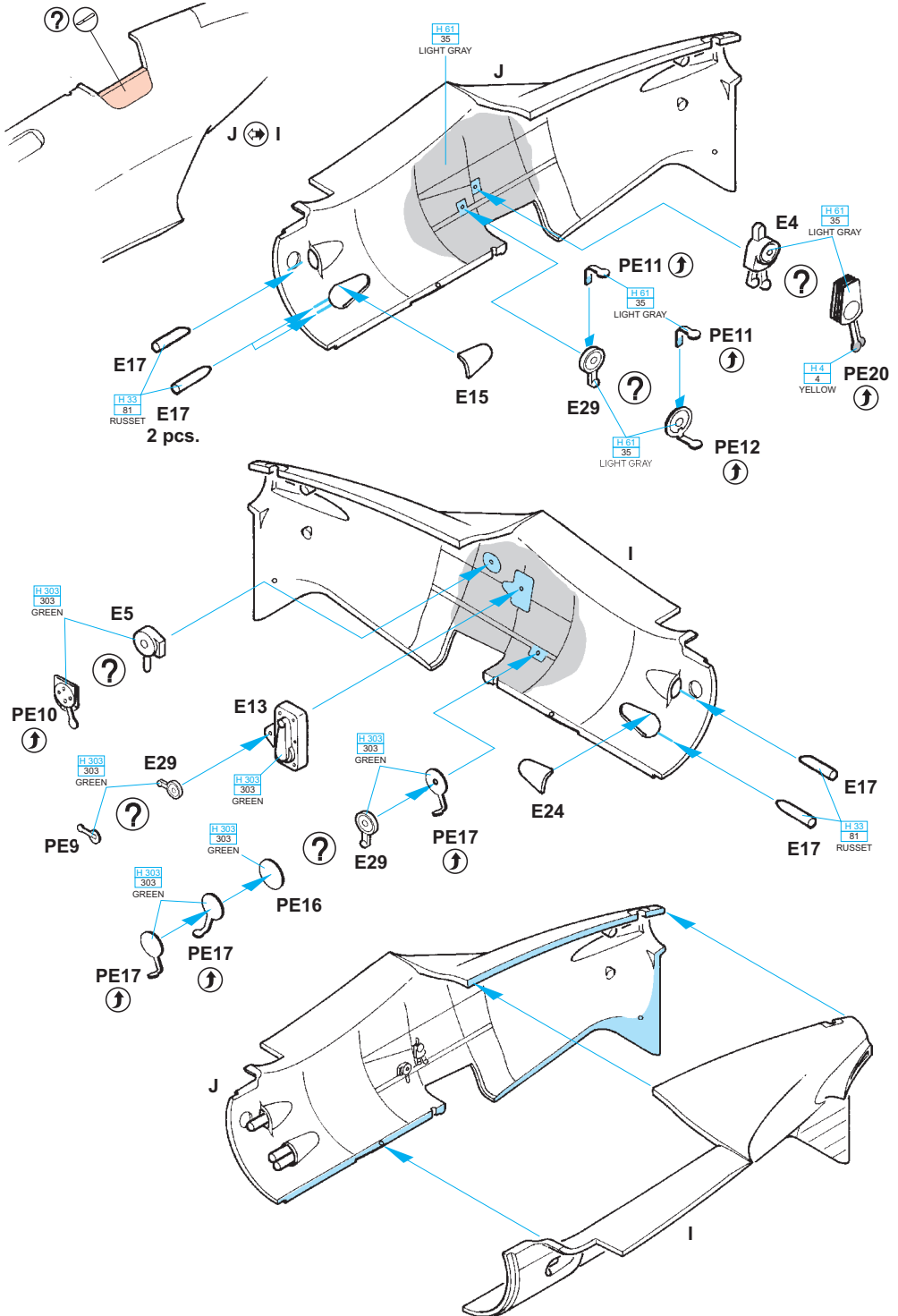

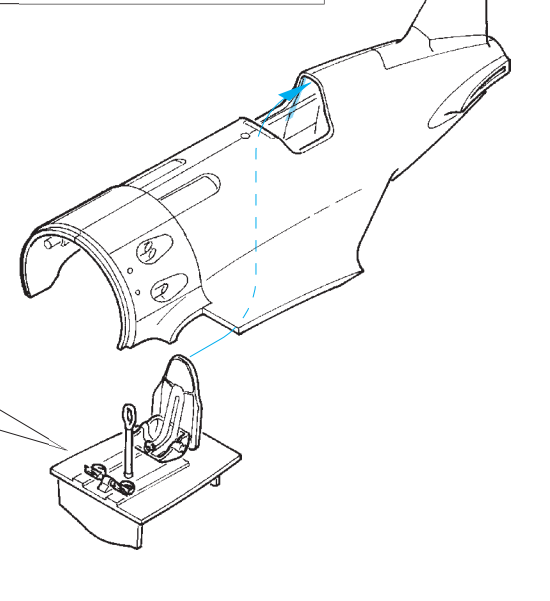
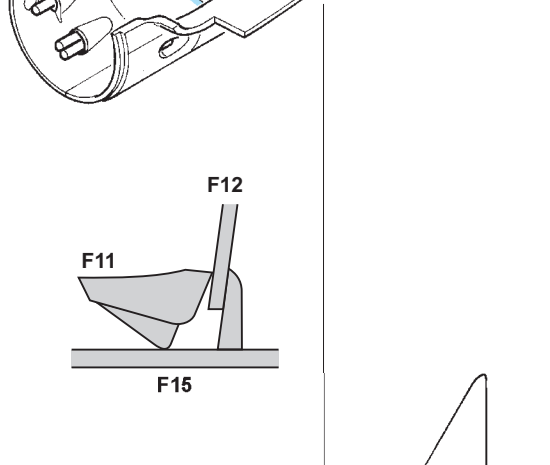
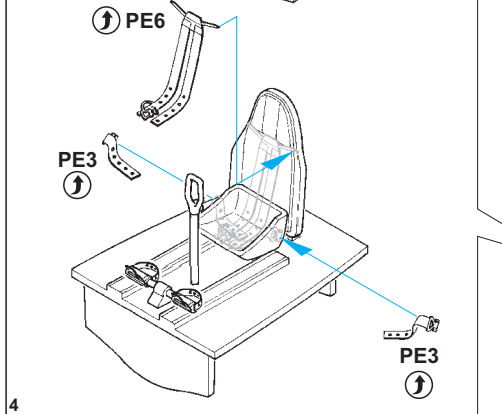
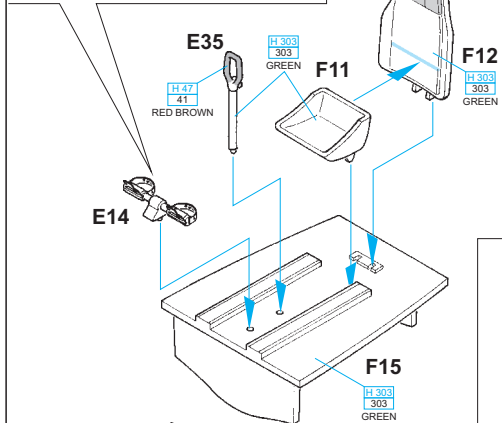
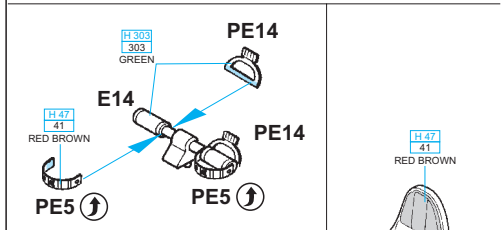
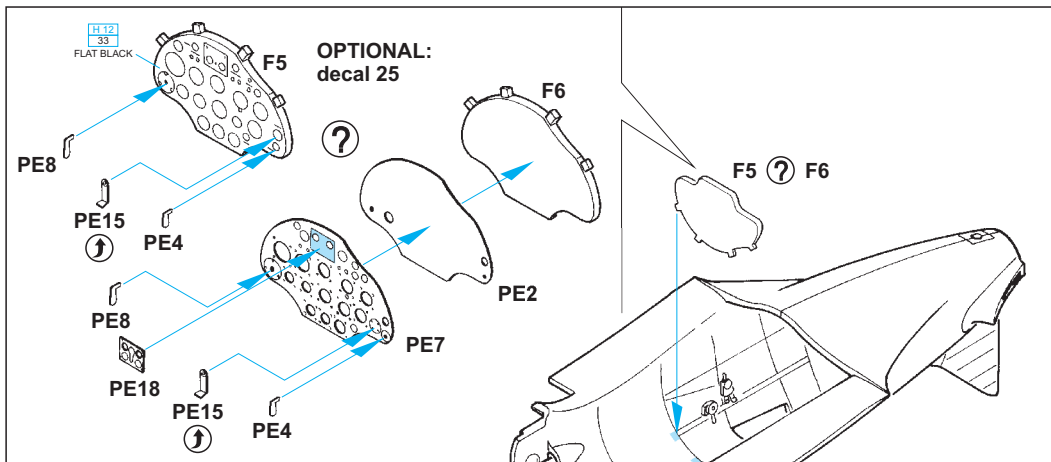

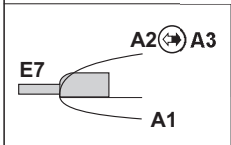
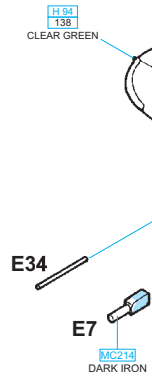
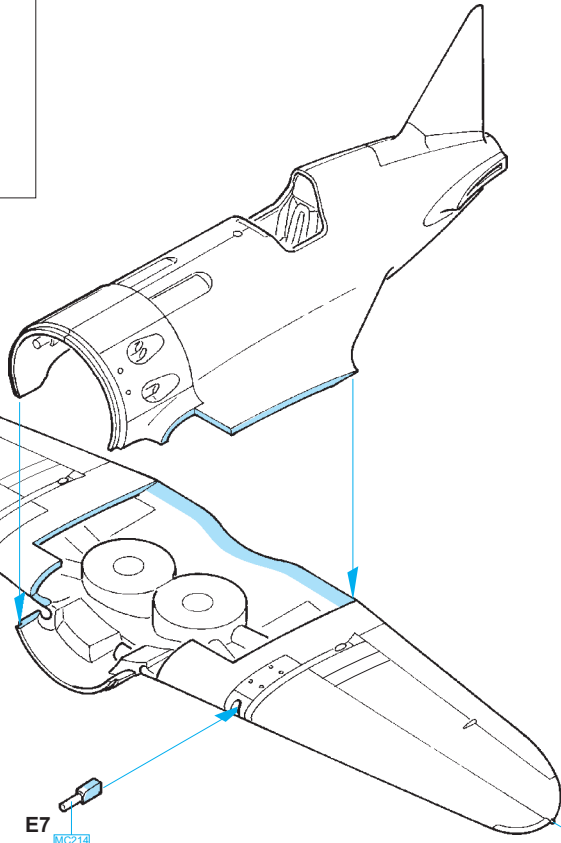
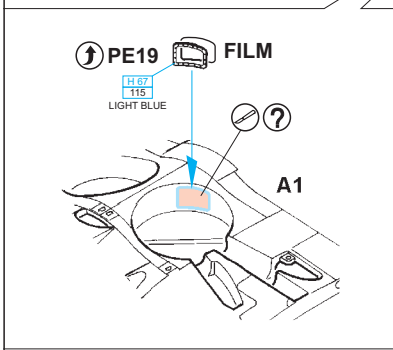
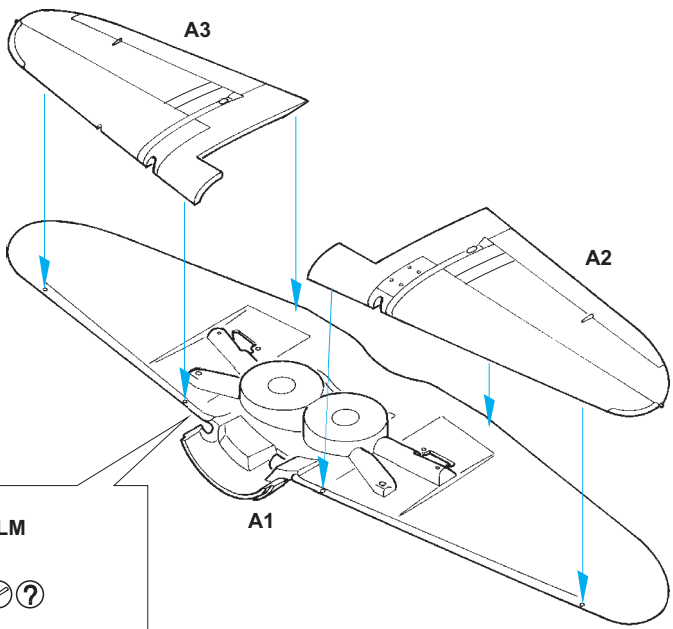

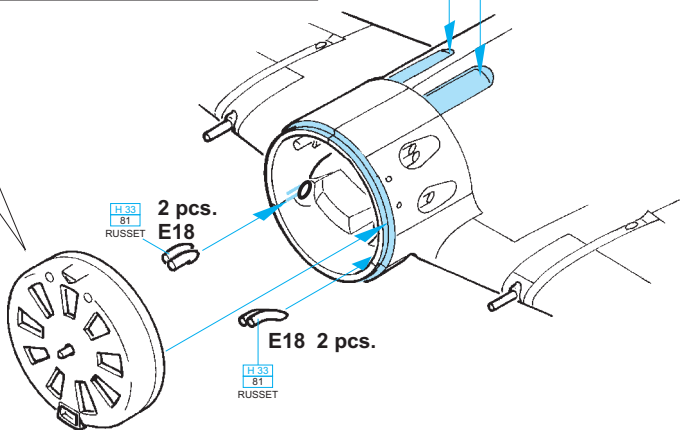
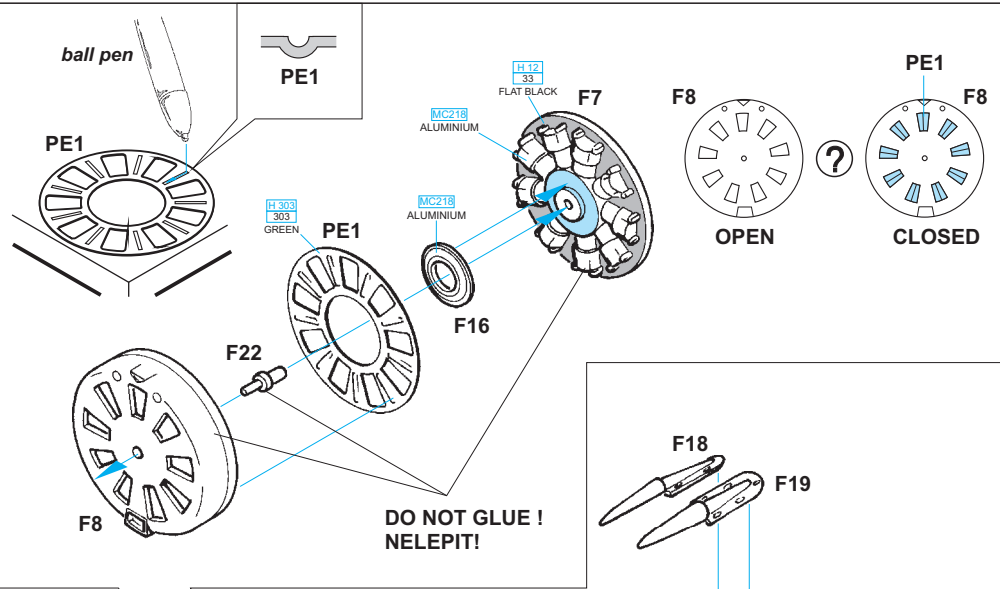
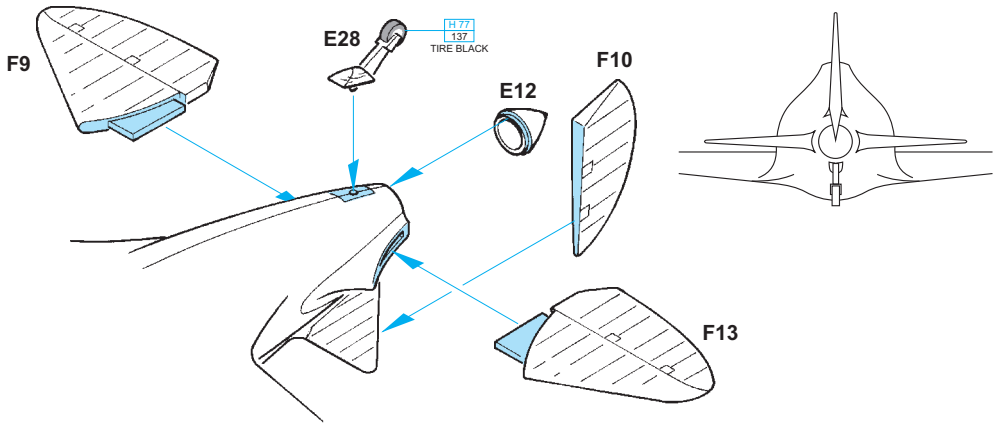

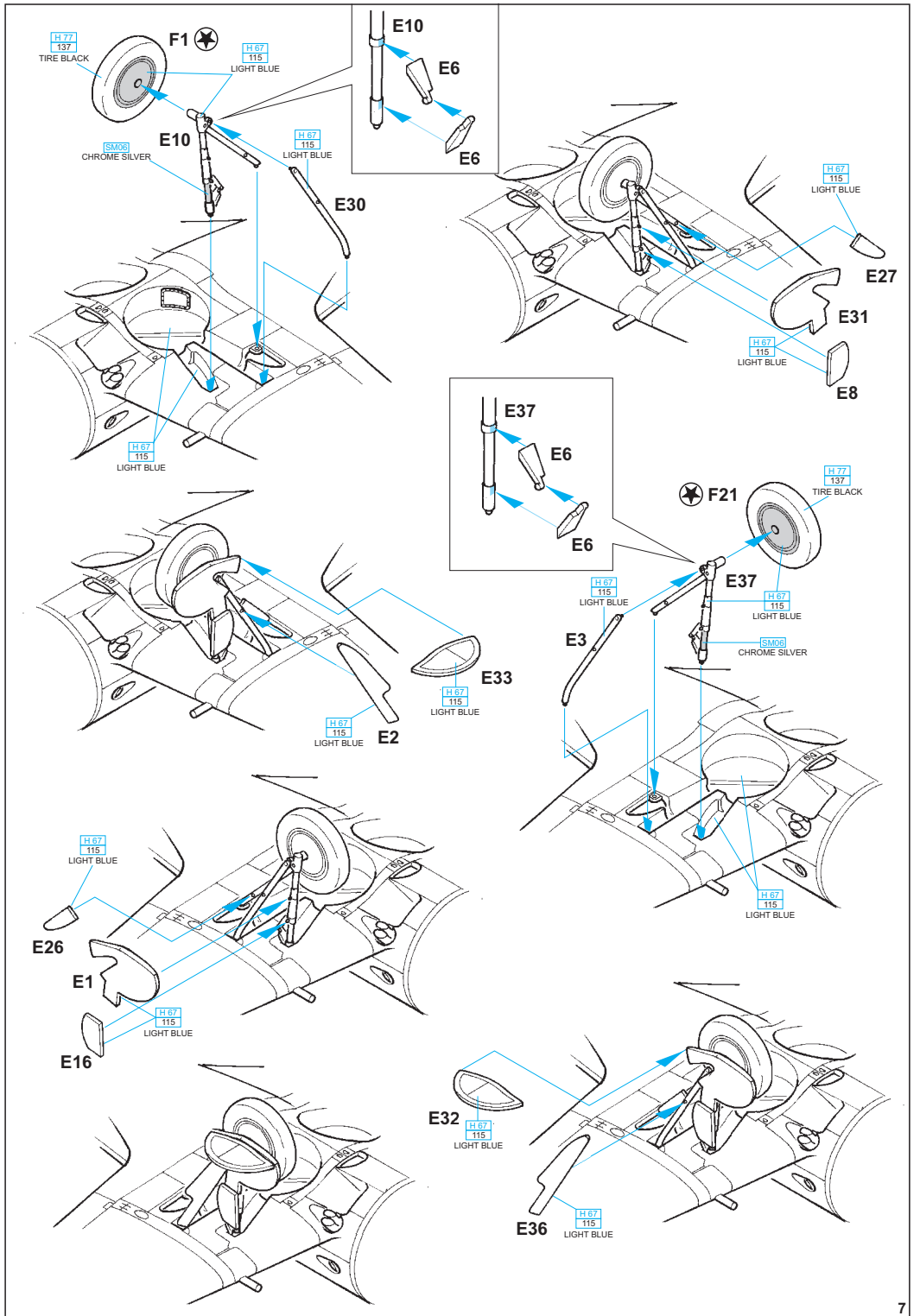

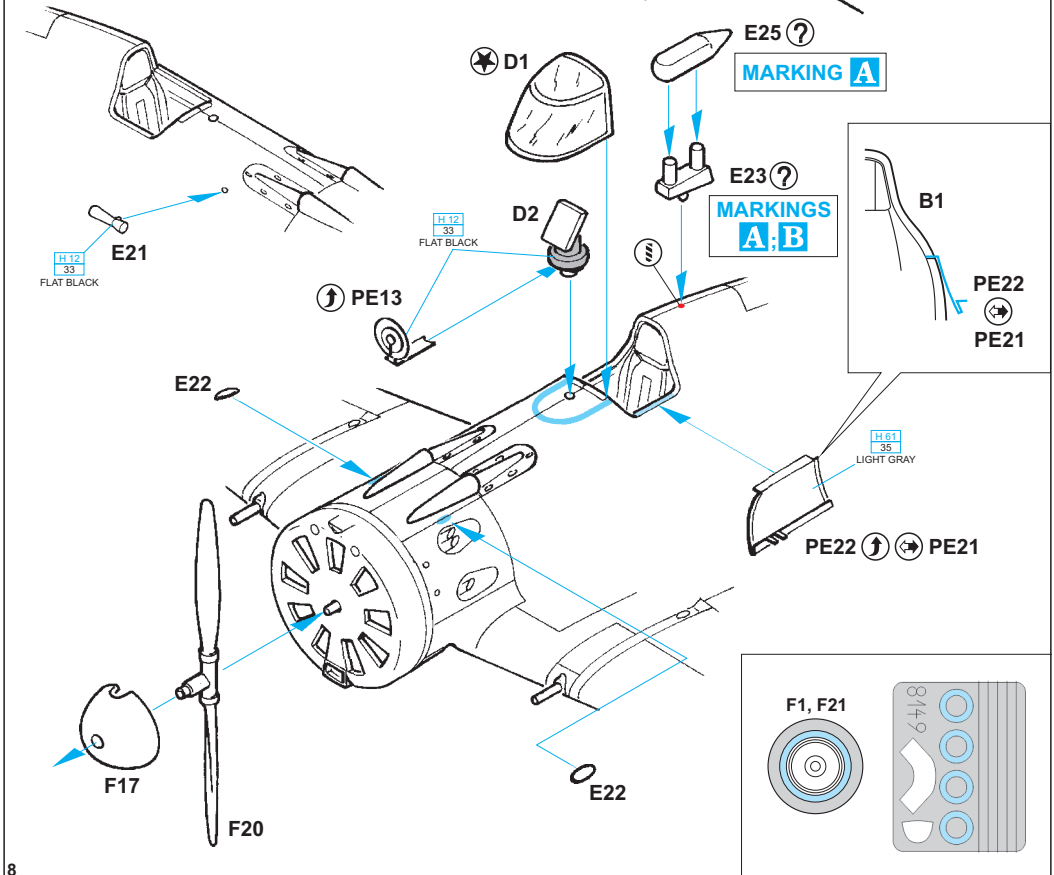
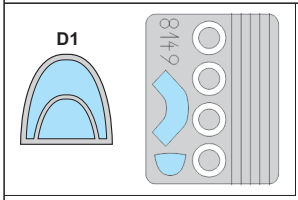
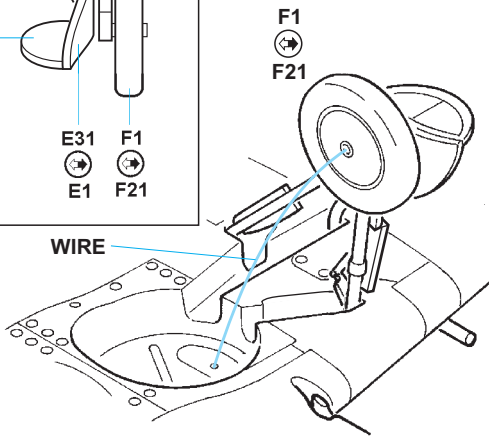
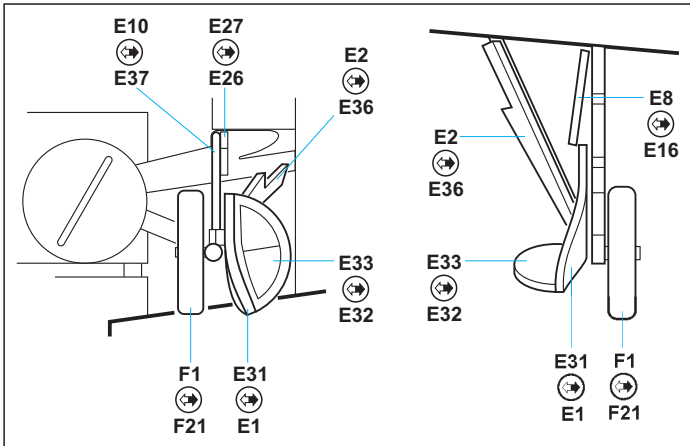

A Boris F. Safonov, 72. SAP, Northern fleet, Summer 1941

Boris F. Safonov was the first pilot serving with the Soviet Navy awarded the Gold Star of the Hero of the Soviet Union during the Great Patriotic War (Sept. 16, 1941). Although this aircraft was on many occasions depicted in various books, it remains a mystery. The left side is quite clear, but the right side has been described to varying degrees. We offer you two versions of the right side slogan. However, the corresponding left side slogan, in this case, is perhaps a simple and erroneous eyewitness flashback. In our mind, there was nothing on the right side except the red star on the fuselage and the number 11 on the rudder. The mysterious slogan "SMERT FASIZMU" was actually painted on the left side of another aircraft, No. 10, which is also noted to have been flown by Safonov. There was also a third aircraft with a patriotic slogan, No. 13 "ZASSSR!" So with that, some of the interpretation will have to be up to you.

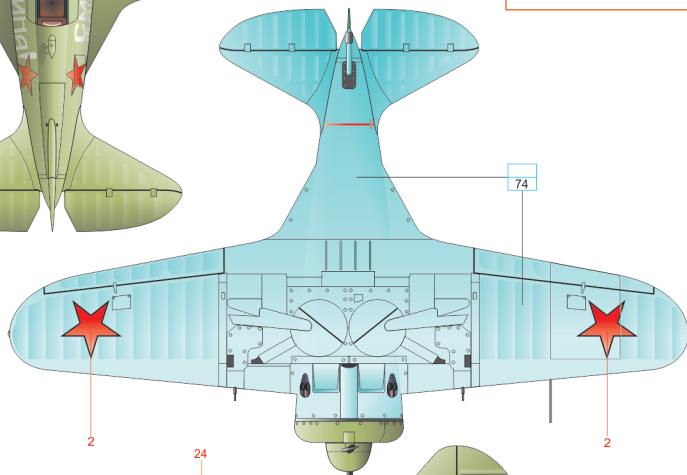
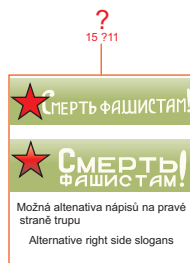
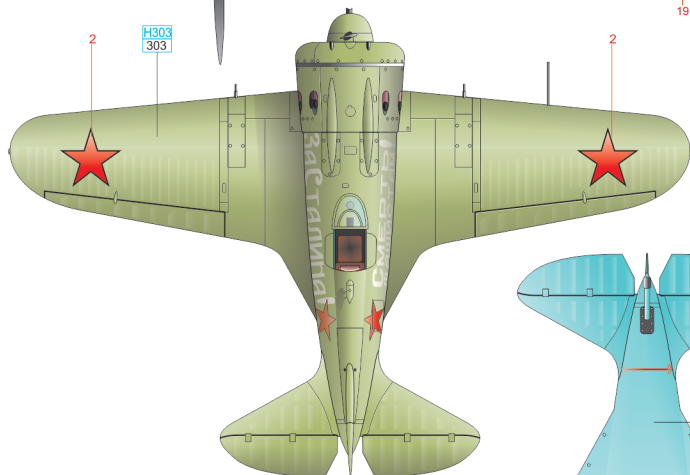
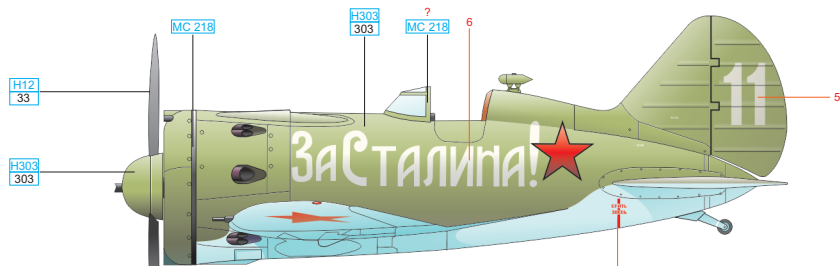

ČESKOU VERZI TEXTU A KOMPLETNÍ KAMUFLÁŽNÍ SCHEMA NALEZNETE NA www.eduard.com/s/8149



ALUMINIUM MC 218

LIGHT BLUE 74

GREEN H303 303

FLAT BLACK H12 33

eduard

B Genadij Tsokolajev, 4.GIAP, Baltic fleet, lake Ladoga, april 1942

Captain Genadij Tsokolajev is another Navy ace with 17 individual and 11 shared victories. He was awarded the Gold Star of the Hero of the Soviet Union on June 14, 1942. It is not certain, if the Guards badge was in reality painted on both sides of the fuselage. Also, the blue bottom surfaces are not definitely ascertained; it is possible the aircraft was light gray overall. Note missing undercarriage doors.

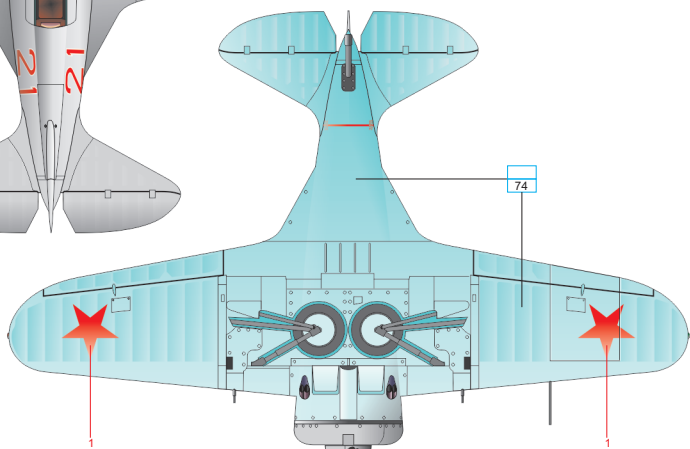
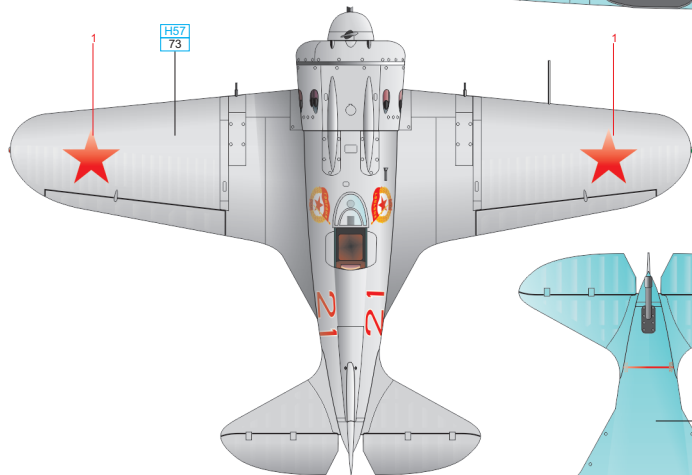
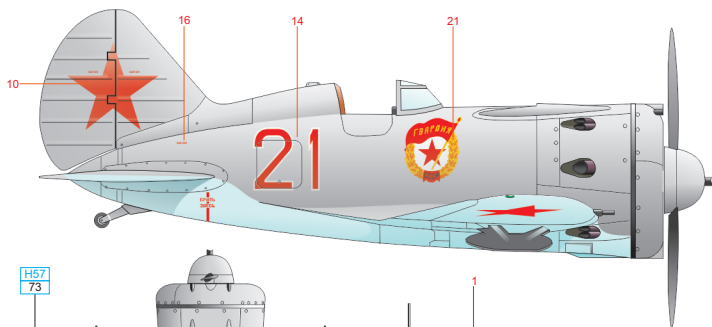

ČESKOU VERZI TEXTU A KOMPLETNÍ KAMUFLÁŽNÍ SCHÉMA NALEZNETE NA www.eduard.com/s/8149

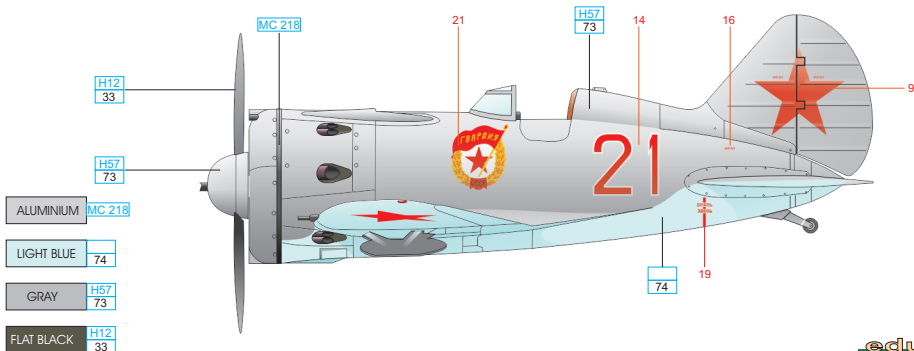

ALUMINIUM MC 218

LIGHT BLUE 74

GRAY H57 73

FLAT BLACK H12 33

eduard

C Lt. Krichevskiy, 254. IAP, Leningrad front, 1942

254. IAP (Fighter Aviation Regiment) was an unit of the 8. SAD (Mixed Air Division), based at Budogosh airfield in the fortified Leningrad area in 1942. The aircraft was painted in a two-tone, pre-war VVS scheme, common in the early Great Patriotic War months, with AII Green upper surfaces and AII Blue lower surfaces. The propeller blades were heavily weathered. Note missing undercarriage doors.

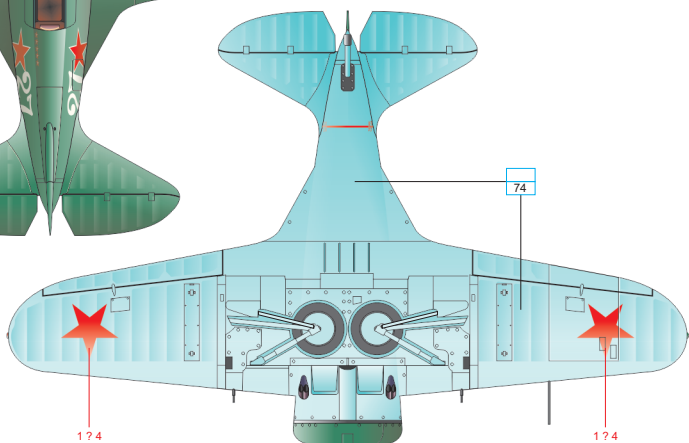
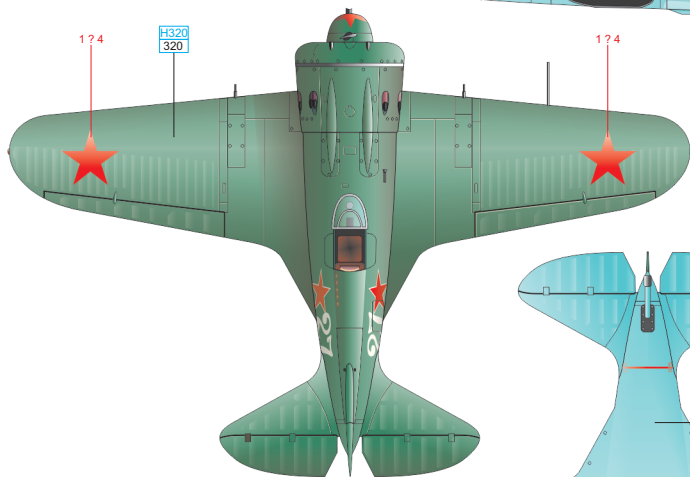
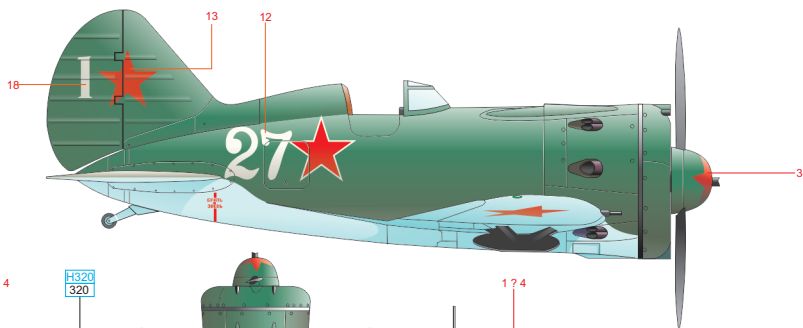

ČESKOU VERZI TEXTU A KOMPLETNÍ KAMUFLÁŽNÍ SCHÉMA NALEZNETE NA www.eduard.com/s/8149

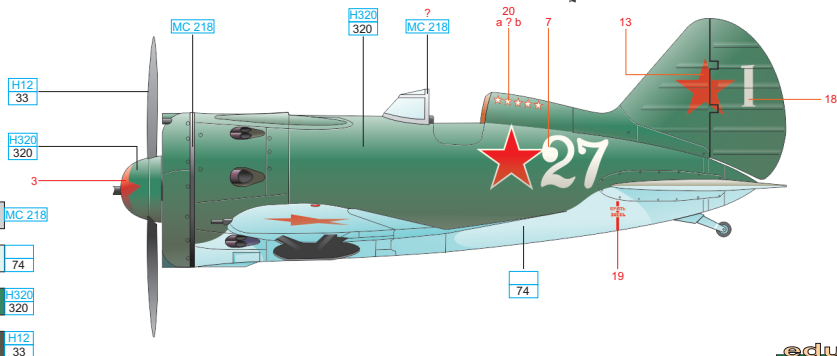

ALUMINIUM MC 218

LIGHT BLUE 74

GREEN H320 320

FLAT BLACK H12 33

D Lev L. Shestakov, 69. IAP, Odessa, summer 1941

69. IAP (Fighter Aviation Regiment), later renamed 9. GIAP (Guard Fighter Aviation Regiment), was commanded by a Spanish Civil War veteran, Lev Shestakov, in the summer of 1941. The regiment took part in the protection of the important south Ukrainian port of Odessa against advancing German and Rumanian troops. Lev Shestakov was an ace with 7 individual and 8 shared victories, with another three (2+1), achieved in Spain. The 9. GIAP gained notoriety later in the war, after re-equipping with P-39 Airacobras, during the Battle of Kuban, under the command of the legendary, three-time Hero of the Soviet Union, A. I. Pokrishkin.

