

Lifelike Decals

48-037

Nakajima Ki-44 Part 2

Limited Edition!

(II Hei)

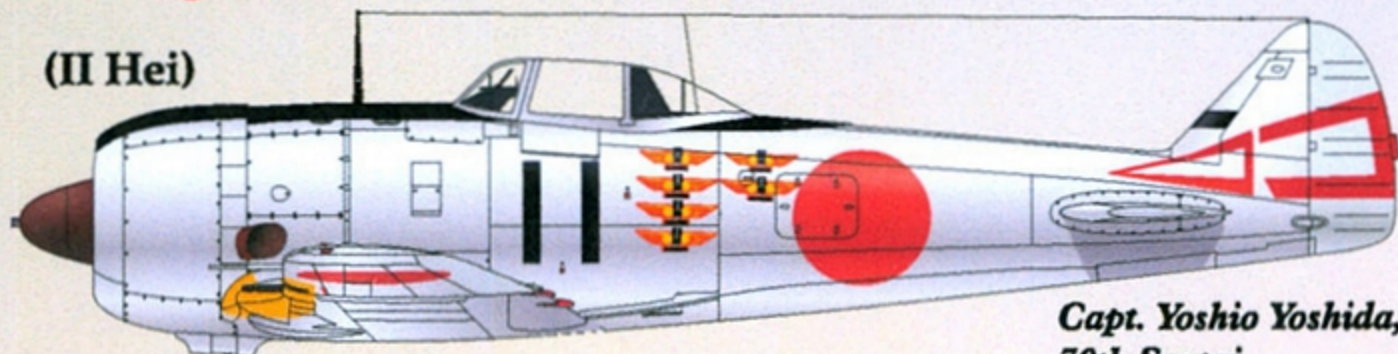

*Capt. Yoshio Yoshida,
70th Sentai*

(II Hei)

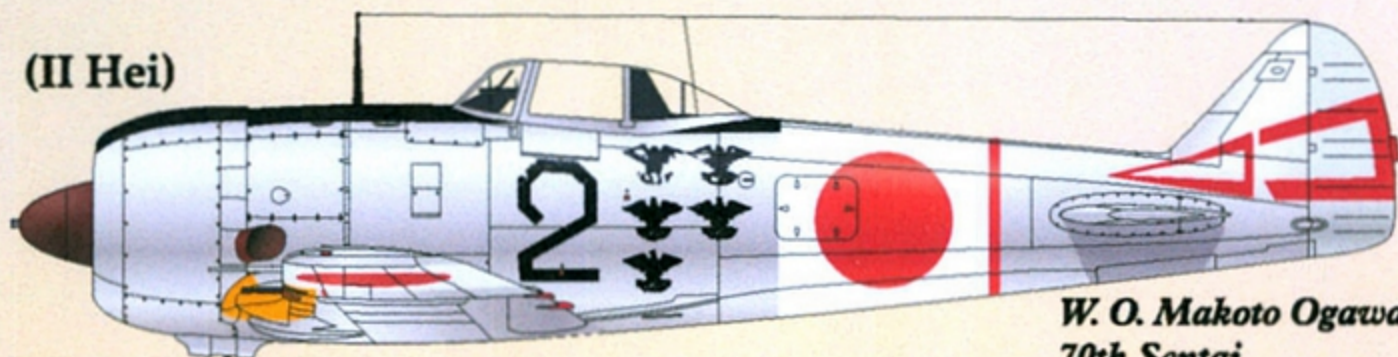

*W. O. Makoto Ogawa,
70th Sentai*

(II Kou)

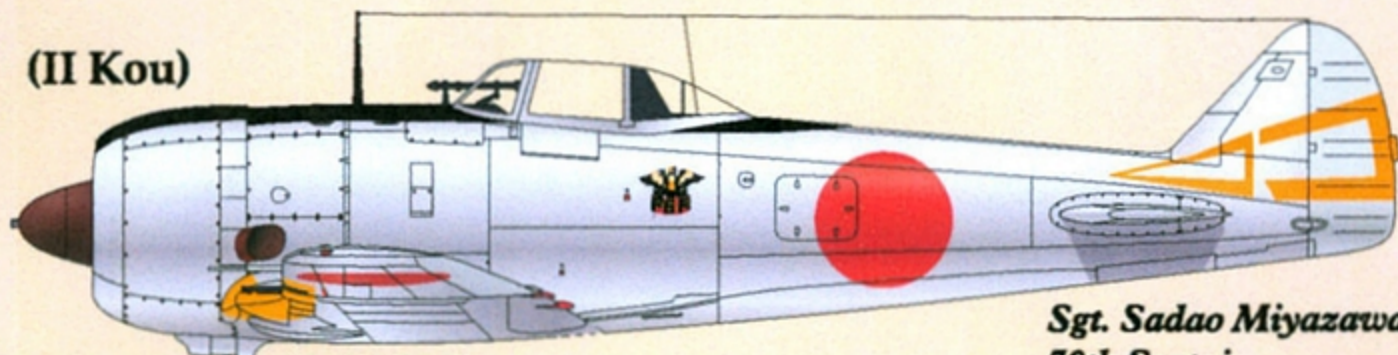

*Sgt. Sadao Miyazawa,
70th Sentai*

(II Kou?)

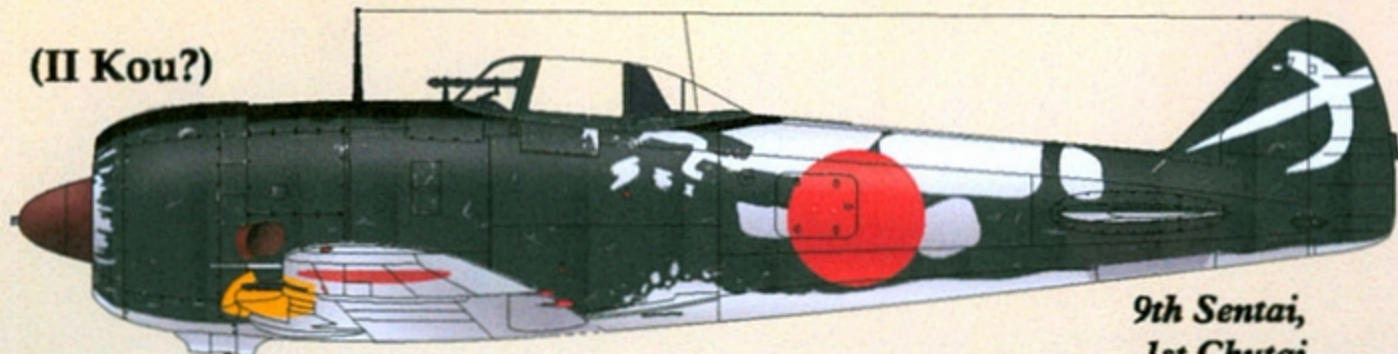

*9th Sentai,
1st Chutai*

© 2011/09

Recommended kit: Hasegawa Ki-44

Lifelike Decals wants to hear from you and your input.

Fax: +81-743-73-5526, e-mail: lifelike_d@kcn.jp

<http://lifelikedecals.sakura.ne.jp>

A/C #1

Shoki type II Hei, flown by Capt. Yoshio Yoshida of 70th Sentai 1st Chutai leader, Kashiwa AB/Chiba, June 1945.

This is a very well known A/C, and its photos are shown in many references (like 1 to 5). Its illustrations are usually shown with yellow Sentai emblem on its tail, as Capt. Yoshida is claimed to be the leader of 3rd Chutai in ref. 6. But the Sentai emblem on its tail is too dark for "yellow" color.

This puzzle was solved by Mr. Watanabe's article in ref. 7, clarifying that Capt. Yoshida was the leader of 1st Chutai, while 3rd Chutai leader was Capt. Tadayoshi Watanabe. This article has another photo showing "yellow" Sentai emblem, and the tonal difference between "red" and "yellow" emblem is very clear. Thus this A/C should have "red" Sentai emblem. The small bar on the leading edge of the tail is slightly darker than

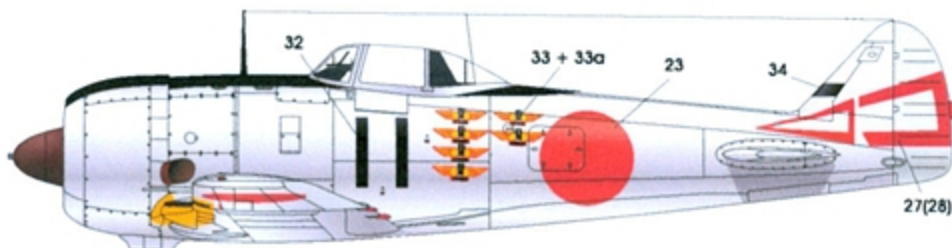

Sentai emblem or Hinomaru, and close to A/C code "11", so we think this is black. But the meaning of this small bar is not known.

There is another photo showing two kill marks in ref. 1 to 5, but A/C code "11" has much peel-off of paint and it lacks the kill (B-29) mark achieved on March 10, 1945. In the 6 kill mark photo March 10's kill mark was added, and A/C code "11" was freshly painted.

Capt. Yoshida was a veteran skilled pilot, serving 70th Sentai from October 1942. His first victory was a "probable" kill of a B-29 on September 8th 1944 in Manchuria. After returning to Kashiwa AB in November, he added 6 more B-29 kills among which 5 kills were achieved in the night interception mission. So he is a very rare "night fighter" ace in Japan, and was awarded the Bukousho medal on July 9th. The war ended, while he was waiting for the arrival of Shusui to 70th Sentai.

A/C #2

Shoki type II Hei, flown by Warrant Officer Makoto Ogawa of 70th Sentai 1st Chutai, Kashiwa AB/Chiba, May to June 1945.

This is also a very well known A/C with stylized kill marks. A total of 3 photos of this A/C are shown in ref. 1 to 8, but like Capt. Yoshida's A/C it is usually illustrated with "yellow" Sentai emblem of 3rd Chutai. But Mr. Watanabe's article in ref. 7 shows he belonged to 1st Chutai, so the Sentai emblem on the tail should again be "red". The overall view photo (without kill marks) does not show distinctive Sentai emblem, but this is apparently due to the dull focus on the tail section.

Its illustration (ref. 3, 4, 5, 9) has always 6 kill marks (stylized eagle) since ref. 2, but the existence of 6th kill mark is quite questionable. The overview photo shows that the white fuselage band is of normal size, i.e., covering whole area of fuselage rectangle panel. Closer look at the much clearer photo of the kill marks in ref. 1 shows the fuselage panel line passes slightly inside the right wing of left row kill marks and body center of right row kill marks. This indicates that the size of the kill

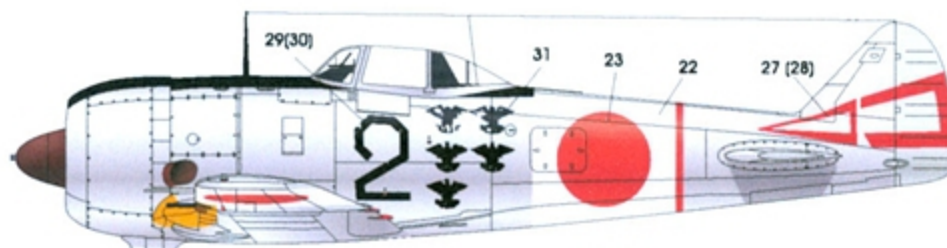

marks are bigger than illustrated, and the position of the 6th kill marks (if any) on the right of the top row should overlap the white fuselage band, which is not so probable from the discipline of Army pilot at that time. Also from the degree of black-grey paint peel-off from the kill marks, it is apparent that top row two kill marks are the oldest ones, the middle row two kill marks are somewhat old, and lower left kill mark is the latest one with solid wing. Then normally speaking the 6th kill mark will be placed on the lower right position. Why extreme right of the top row? So we think the number of kill marks applied is just 5, not 6, and we reproduced the peel-off of black-grey paint from the kill marks and

A/C code "2".

W. O. Ogawa was a veteran skill pilot, serving 70th Sentai from the end of 1941, but there were not so many chances of air combat in Manchuria, and the Sentai was ordered to return to Home Defense duties. W. O. Ogawa achieved a total of 9 victories (7 B-29s and 2 P-51s) to become the top ace of the Sentai. In the day-time interception of February 10th, he shot down two B-29s with several shots of 40mm cannon (second A/C fell down from the debris of the first A/C blast), and he shot down another B-29 in the night interception of March 10th. He was awarded Bukousho on July 9th 1945 with promotion to 2nd Lt, and lived through the war.

A/C #3

Shoki type II Kou, flown by Sgt. Sadao Miyazawa of 70th Sentai 3rd Chutai (?), Kashiwa AB/Chiba, February 1945.

Though this A/C is rather little known, this is another example of Shoki with a kill mark. Its photo (the only recorded one) was shown in ref. 1 and 3, and shows the clear details of Sgt. Miyazawa's kill mark applied by his crew chief. He scored this victory (F6F) on February 17, 1945, and shows this date (1945 is Showa year 20) below the bird mark. In the old reference 1 Sgt. Miyazawa as well as Capt. Yoshida and W.O. Ogawa were all assigned to 3rd Chutai, and 3rd Chutai is said to be the only Chutai to adorn their A/C with kill marks. The latest article by Mr. Watanabe (ref. 7) regrettably



does not clarify whether Sgt. Miyazawa belonged to 3rd Chutai or 1st Chutai nor the kill marks were applied on A/C of other Chutai or not, so the Sentai emblem color of this A/C is not 100% sure. If only the Chutai of Capt. Yoshida (now established as 1st Chutai) had kill marks,

this A/C should have red Sentai emblem. If Sgt. Miyazawa is indeed 3rd Chutai member, Sentai emblem should be yellow. We provide both options for you to choose.

We do not know the career of Sgt. Miyazawa except his one victory on February 17, 1945.

A/C #4

Shoki type II Kou?, flown by 9th Sentai 1st Chutai, China, 1944-45.

Though the 9th Sentai is known to have flown Shoki in China, we could not find any such photo, but only some illustrations in ref. 6, 10 and 11. These illustrations show the Sentai emblem (symbolizing the scythe that Japanese Samurai Kiyomasa Kato used in Japanese invasion of Korea in 1590s) in a very slim style. But the photo of abandoned Oscar in Nanjing (ref. 12) or Hayate in Korea (ref. 13 and another once shown on the internet) after the war clearly shows the 9th Sentai emblem is more bold and covering most area of the tail.

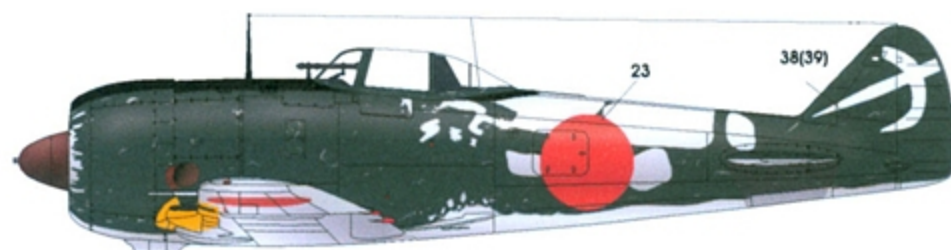

This decal reproduces the mark worn by the photographed Oscar. (Though Oscar is not known to be assigned to 9th Sentai, the A/C in ref. 12 photo is not Shoki but Oscar due to relative position of wings and

stabilizer to canopy and tail.)

It is claimed that the Sentai emblem was unified to the red one from January 1944, but the above Hayate photos clearly show 1st Chutai continued to use white emblem till the war's end.



A/C No.2



A/C No.1, 3

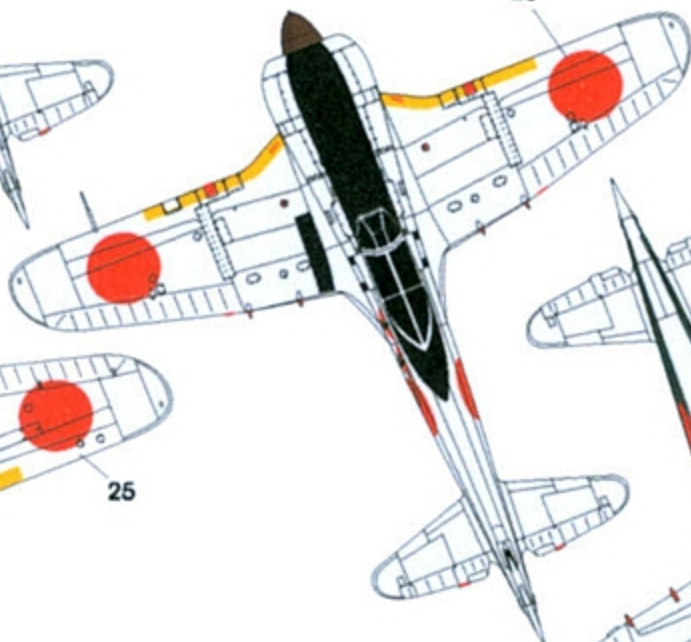

A/C No.4

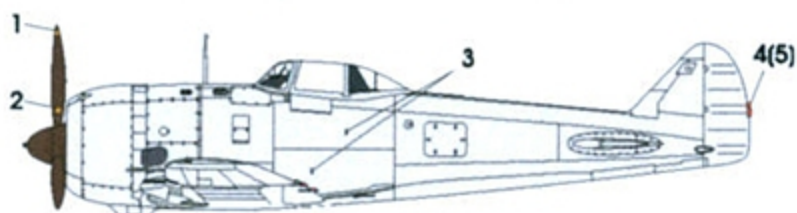
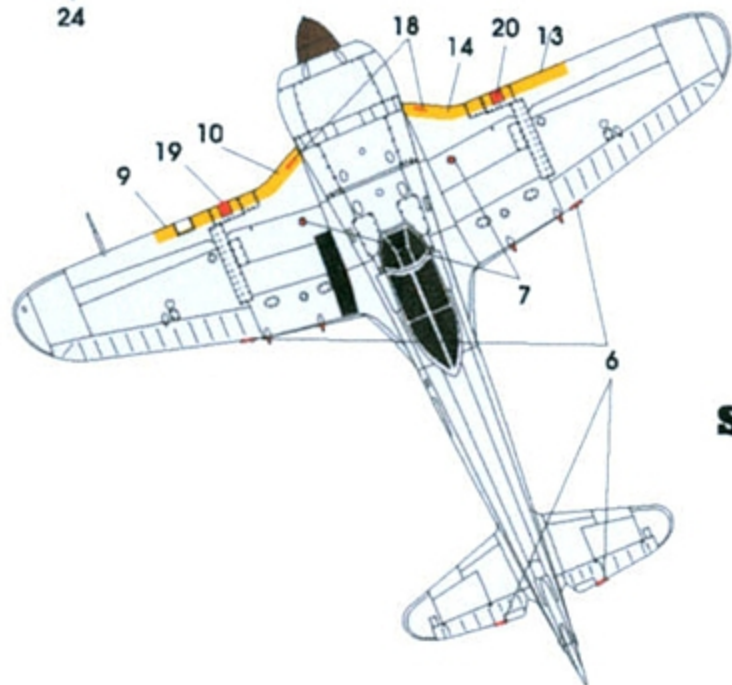
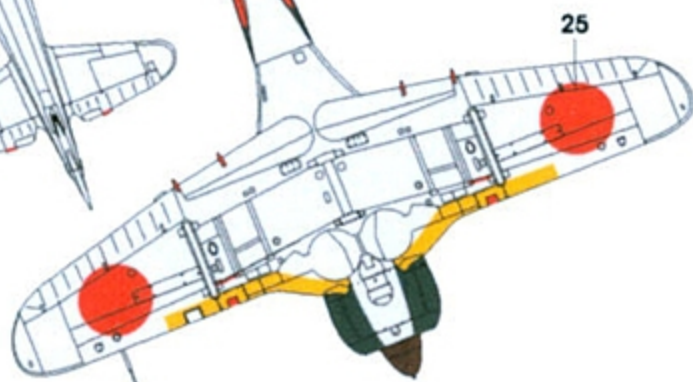
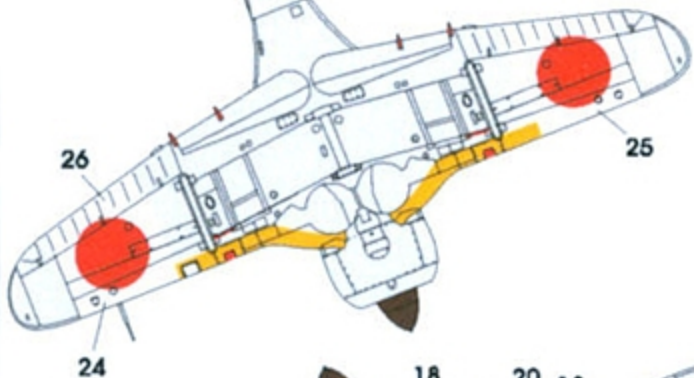

Stencils

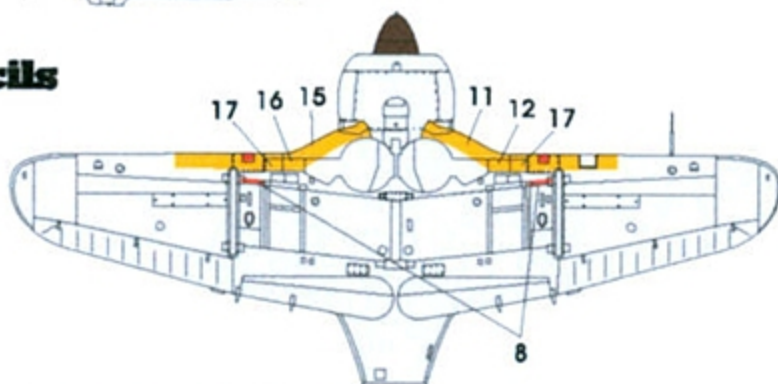

References;

1. Pictorial History of Air War over Japan - Japanese Army Air Force (Yoji Watanabe, Hara Publ., 1980)
2. Model Art #416 Medaled Pilots of Japanese Army Air Force in WWII (Model Art, 1993)
3. Osprey Aces 13 Japanese Army Air Force Aces 1937-45 (Osprey publ., 1997)
4. Osprey Aviation Elite 5 B-29 Hunters of the JAAF (Osprey Publ., 2001)
5. Pictorial History of the 70th Sentai (Dainippon Kaiga, 2009)
6. Japanese Army Fighter Force and Aces in WWII (Hata/Izawa, Kanto-sha, 1984)
7. Koku-Fan magazine March 2009
8. Famous Airplanes of the World No. 16, Type 2 Fighter Shoki (Burrin-do, MAy 1989).
9. Aero Military Collection 6-Japanese Army Fighter (Koei Publ., 2006)
10. Famous Airplanes of the World No. 147, Type 2 Fighter Shoki (Burrin-do Pub., January 1985).
11. Model Art Profile 5 - Ki 44 Shoki (Model Art, 2009)
12. Le Fana de l'Aviation (French magazine), No. 54 (May 1974)
13. Air Combat over China of Ki44 and Ki84 in 1943-45, 9th & 85th Sentai (Dainippon Kaiga, 2008).