



Third Group™



PO BOX 98865 • TACOMA WA 98498-0865 • USA
Tel: (253) 475-9505 ~ Fax: (253) 475-1597 ~ Email: tgdecals@aol.com

A THREE GEESSE PUBLISHING COMPANY

48-045

1:48
scale

Focke-Wulf Fw 190 #10 – Survivors #2 A-3/F-3/8

Fw. Eugen Lörcher, 5./SG 2

Fw 190F-8 – Germany – Summer 1945



Ofw. Josef "Sepp" Enzenberger, II/SG 10

Fw 190F-3 – Germany – May 8, 1945



Fw 190A-3, WNr 2168 – Germany – Summer 1945

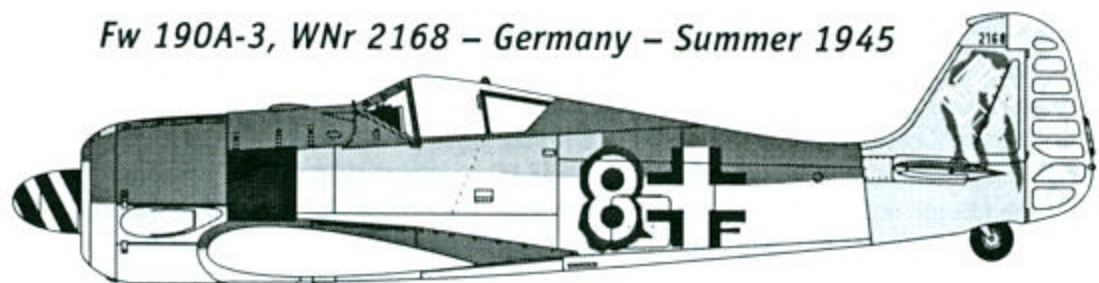

Fw 190F-8, WNr 582384 – Germany – Summer 1945

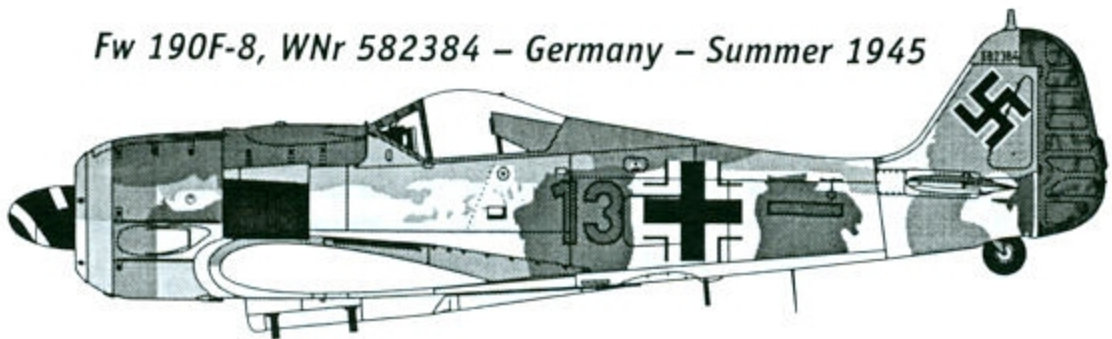

Black 3

RLM 83 mottled with RLM 81

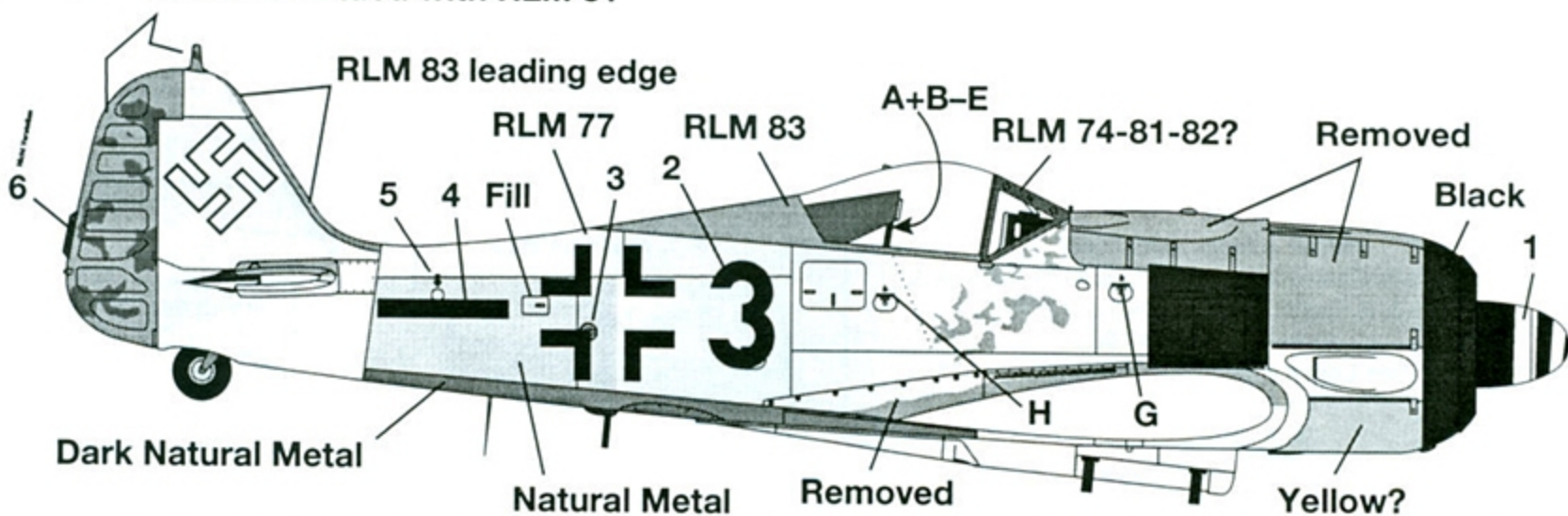

(leading demarcation just forward of fuselage cross center, at rivet line not present on kit)

Black K

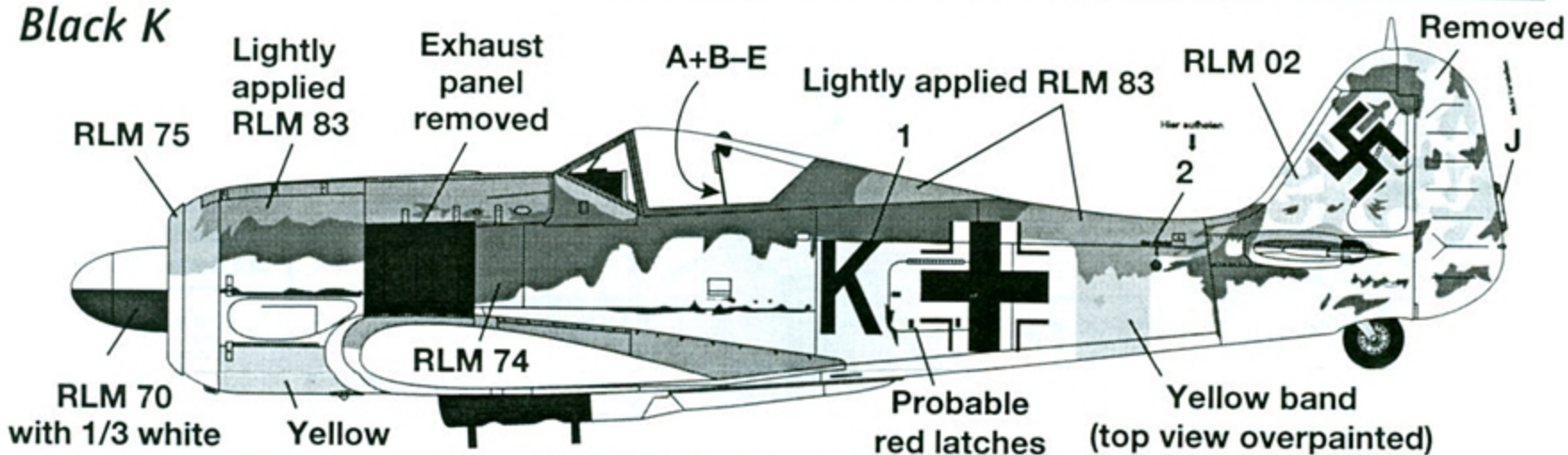

White/Yellow 8

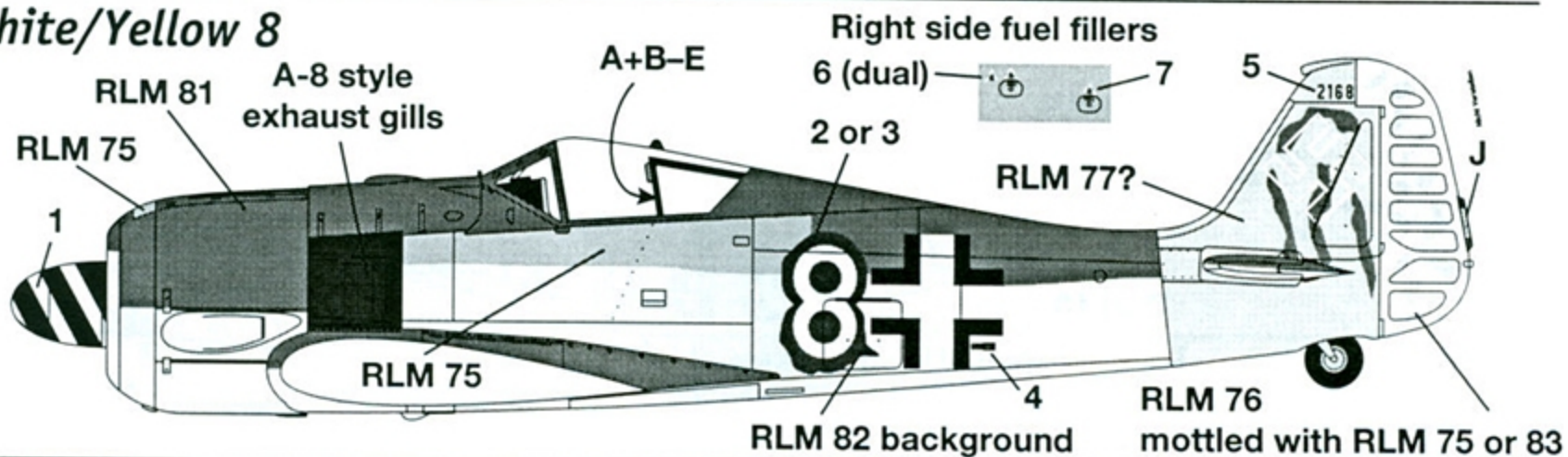

Red 13

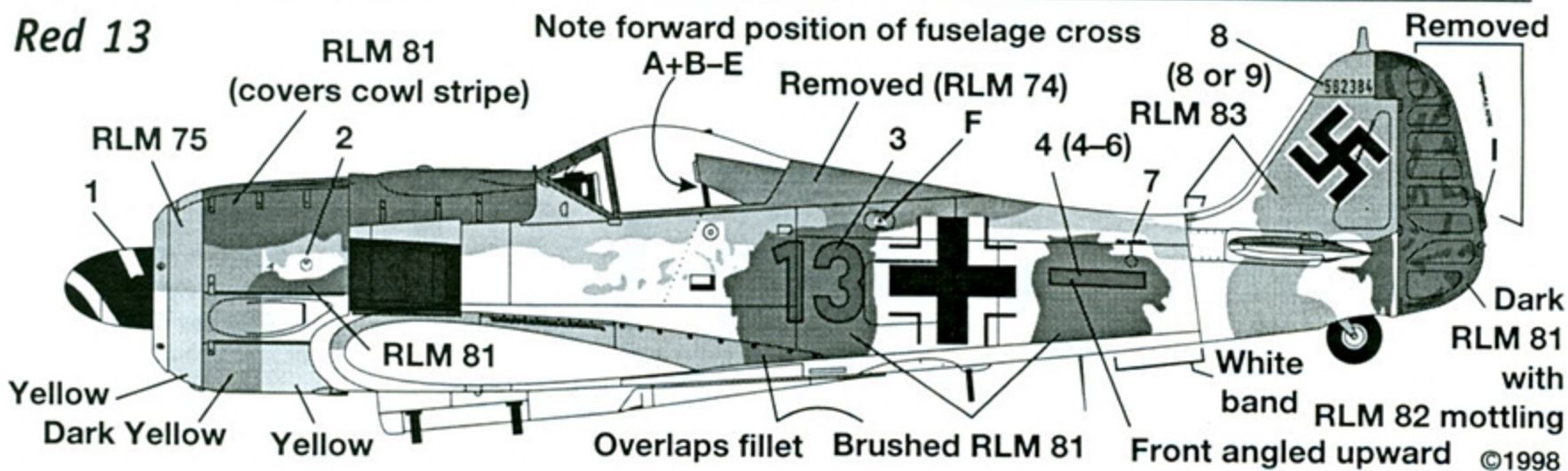

Some upper surface patterns are conjectural as they are washed-out in reference photographs or are not visible. Contrary to popular belief, quite a number of Fw 190s had nonstandard upper surface camouflage. If possible, review the listed references and make your own determination regarding camouflage colors.

For scale plan views, enlarge by 200%

REFERENCES

A: *Jet & Prop*, 3/95: 1995
B: *Luftwaffe Camouflage & Markings 1935-45, Vol. 3:* J. R. Smith & J. D. Gallaspy, 1977
C: *Le Focke Wulf 190:* Jean Yves Lorant & Jean Bernard Frappé, 1981
D: *Airfoil #5*, 1987
E: *Airfoil #2*, 1984

Left upper surfaces not visible (left wing based loosely on similar aircraft at Grove, Denmark)

Black 3

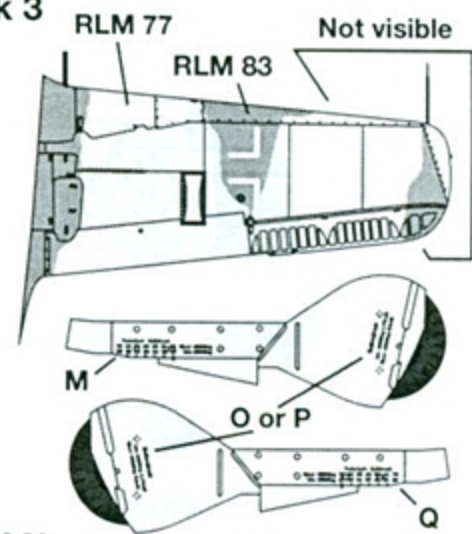
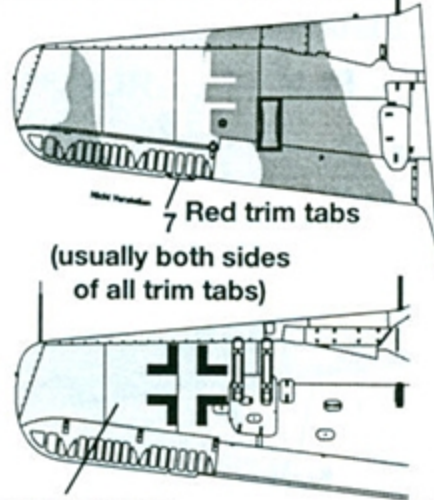

Outboard gun ports not faired

Leading edge visible **Black K**

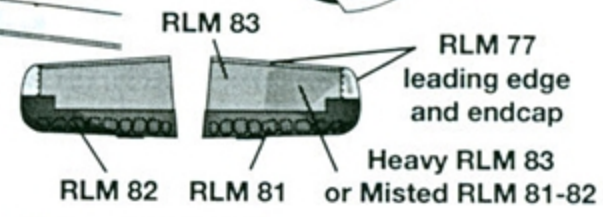
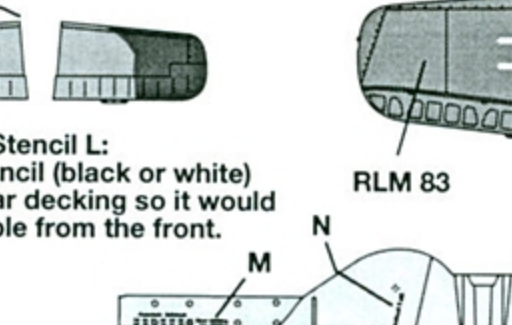
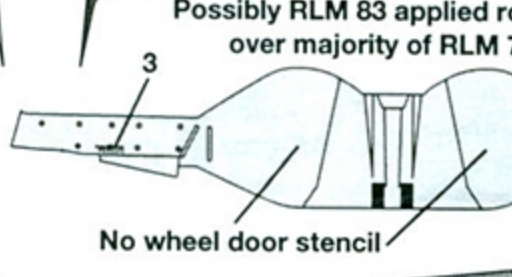
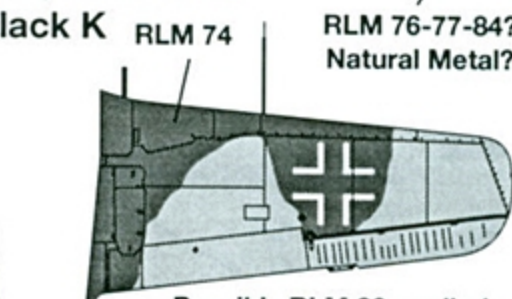
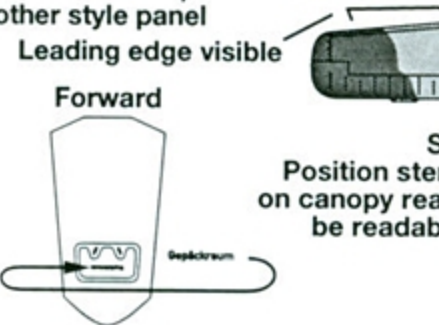
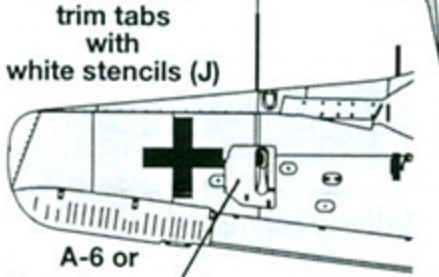
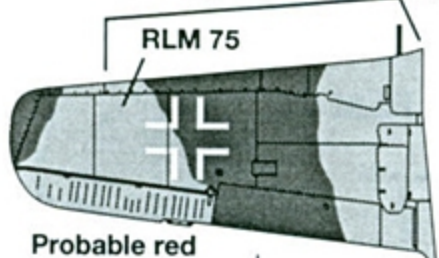

Outboard ticks of stencils M & Q removed to accommodate kit.

Upper wing crosses are Focke-Wulf standard, meaning they are nonregulation.

White/Yellow 8

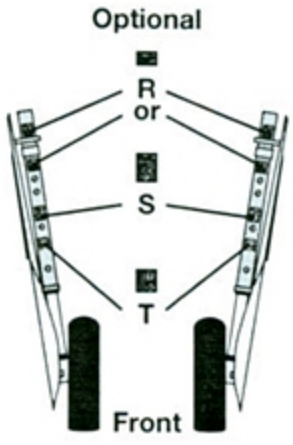
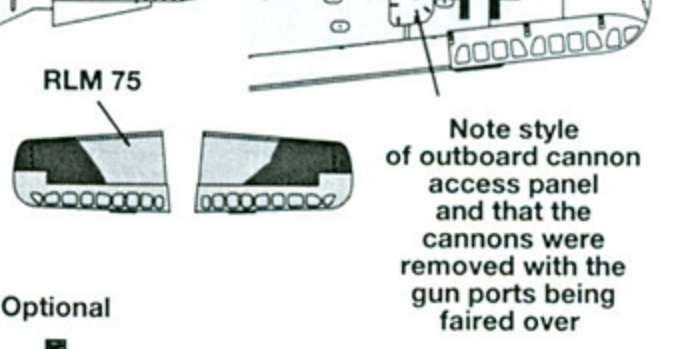
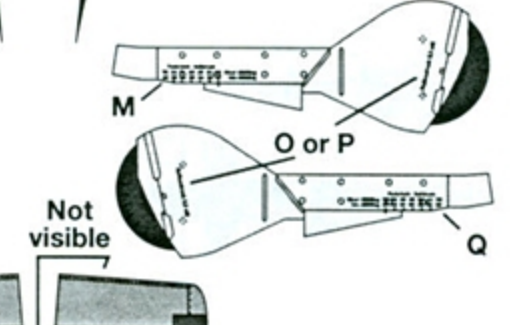
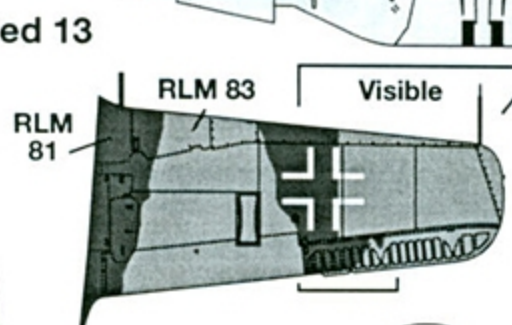
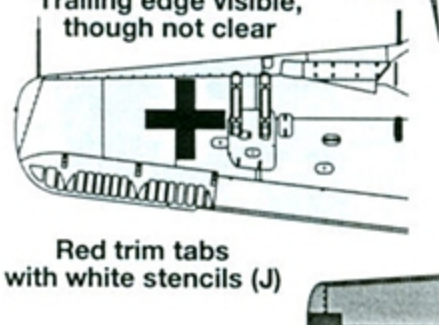
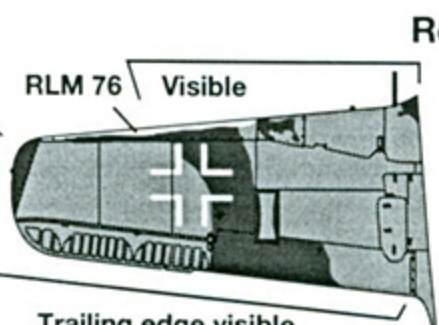
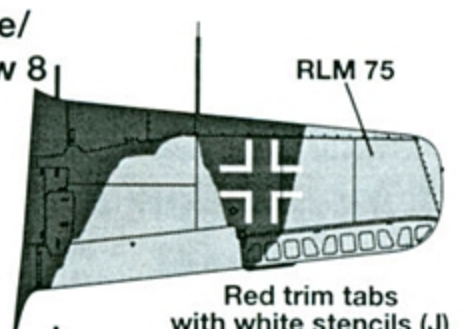
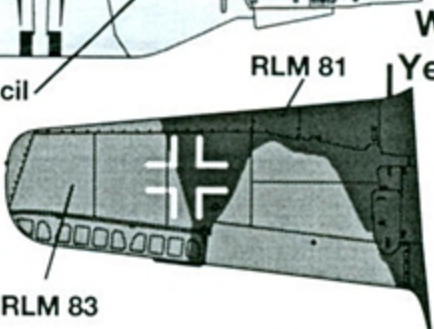

Special thanks to Robert P. Morrison, George R. Morrison, Jr. & Werner Stocker for research assistance.

Equipment: All except White/Yellow 8 probably had an ETC 501 centerline rack and possibly a Morane antenna. It was common to remove the FuG 25 antenna from aircraft on the Eastern Front, though some did carry it.

Stencils: Provided stencils are known or likely. Four variants are provided for the armored headrest: B, C, D & E, of which B was the most common. See the kit for additional stencils, though keep in mind these aircraft probably had minimal stenciling.

Black 3: Fw. Eugen Lörcher belly-landed Black 3 at the end of his "West is Best" flight during May, 1945 while carrying a passenger in the rear fuselage – his fiancée!

Equipment: Blown canopy. Right fuselage first aid cross compartment omitted, so kit panel lines should be filled. Upper engine cowling, gun cowling, and right wingroot fillet not present. Probable ETC 50 or 71 wing racks. **Camouflage:** RLM 77 fuselage (some say natural metal) with light RLM 83 mottling on forward fuselage, natural metal lower rear panel and dark natural metal lower rear fuselage, black cowl ring, RLM 74 or 81 or 82 windscreen frame, RLM 83 rudder mottled with RLM 81, right tail has four upper colors (RLM 77/81/82/83). Probable white-spiraled black spinner. Underside wing camouflage is speculative: RLM 76, RLM 84, natural metal, combination? **Markings:** White upper wing crosses, black outline fuselage crosses and swastikas. Probable black outline lower wing crosses. **Stencils:** Known stencils are 3, 5, 6 & 7. Fuel filler triangles, if present, would have been on or above the hatches. An optional six-digit Werknummer may be made from those provided and applied to the left side. The '58x' sets are block numbers. Pre-made and individual trailing numbers provided. **Reference: A - 16 & 18.**

Black K: Ofw. Josef "Sepp" Enzenberger crash-landed this F-3 on his freedom flight to Western occupied territory. This probably was not Sepp's aircraft but rather one that just happened to be available when it was time to go. **Equipment:** Standard canopy. ETC 50 wing racks may have been fitted. **Camouflage:** RLM 74/75/76 with RLM 83 roughly applied over fuselage RLM 74 and possibly areas of wing. Black (or RLM 70) spinner with 1/3 in white, yellow fuselage band. Probable yellow lower engine cowling. **Markings:** Standard fuselage crosses and white-bordered swastikas, and white outline upper wing crosses. Unknown style of lower wing crosses. **Stencils:** Known stencils are 2.

Reference: A - 17.

White/Yellow 8: A rare Focke-Wulf for 1945. A-8 add-ons make it rarer still. **Equipment:** Standard canopy. A-8 style exhaust gills (use aftermarket photoetch, or use the DML A-4 as a basis for it comes with early and late style exhaust gills). Clean lower wing (no rack nor Morane antenna) with inboard gear doors, A-8 main wheels and gear strut door stencils, and odd style lower wing outboard cannon access panels. Interestingly, considering the odd style access panels, the outboard cannons were removed and the gun ports faired over. **Camouflage:** RLM 81/75/76 fuselage, RLM 75 cowl ring upper panel, RLM 77(?) empennage mottled with RLM 81, RLM 76 rudder mottled with RLM 75 or 83, white-spiraled black spinner (conjectural style as only the end is visible). Upper camouflage is a close mirror pattern with one color change: RLM 81/83 left wing, RLM 81/75 right wing, and RLM 81/75 horizontal tail. **Markings:** White outline upper wing crosses, black outline lower wing and fuselage crosses, and white outline swastikas. In-Staffel number (white or yellow; our guess is white) on RLM 82 background. **Stencils:** Known stencils are 4 (two data plates), 6, 7 & L. **References: B - 138; C - 390, 391 & 393; D - 14, 16 & 17.**

Red 13: Either long-lived or a rebuild. **Equipment:** ETC 50 wing racks, and possibly a blown canopy (removed). **Camouflage:** RLM 74/75/81/76 fuselage with dark yellow cowl ring (upper area overpainted with RLM 81), yellow lower engine cowling, brushed RLM 81 markings background, partially overpainted white fuselage band. RLM 81/83/76 vertical tail with dark RLM 81 rudder mottled with RLM 82. **Markings:** Standard fuselage crosses (forward of usual), white-bordered swastikas, and white outline upper wing crosses. Unknown style of lower wing crosses. **Stencils:** Known stencils are 2, 7, F (upper point covered by RLM 81 mottle) & I. **Reference: E - 17, 20 & 23.**