

MINIATURES SERIES

# PASSENGER BUS GAZ-03-30

38005



## GENERAL INSTRUCTION

- HIGHLY DETAILED MODEL
- TOTAL DETAILS 331
- 297 PLASTIC PARTS
- 8 PHOTOETCHED PARTS
- 26 CLEAR PLASTIC PARTS
- DECALS SHEET FOR 8 OPTIONS
- FULL-COLOUR INSTRUCTION
- 4 VARIANTS OF BUS Mod. 1938
- 4 VARIANTS OF BUS Mod. 1945
- FULLY DETAILED ENGINE COMPARTMENT AND CHASSIS
- UP-TO-DATE TECHNOLOGY USING SLIDING MOULDS

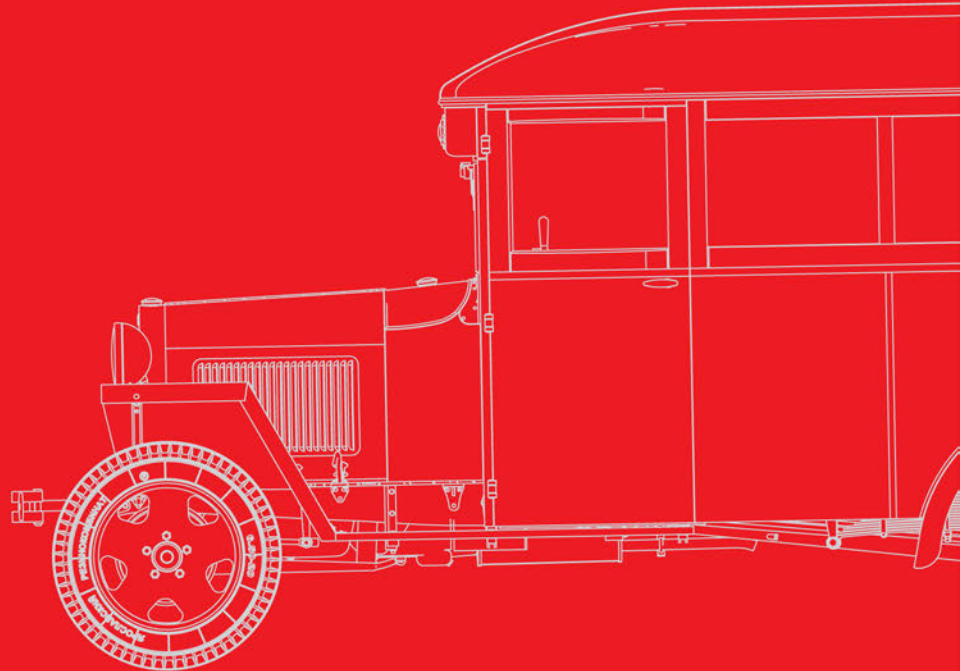

MiniART : 38005

Service bus for the Ministry of Internal Affairs of the Byelorussian Soviet Socialist Republic, Minsk, 1946-58.

Служебный автобус Министерства Внутренних Дел Белорусской ССР, Минск, 1946-1958 годы.

COLOR NAME	AMMO
Rubber & Tires	A.MIG-033
Dark Tracks	A.MIG-035
Matt Black	A.MIG-046
Red	A.MIG-049
Crystal Red	A.MIG-093
Medium Blue	A.MIG-103
Grey Shadow	A.MIG-906

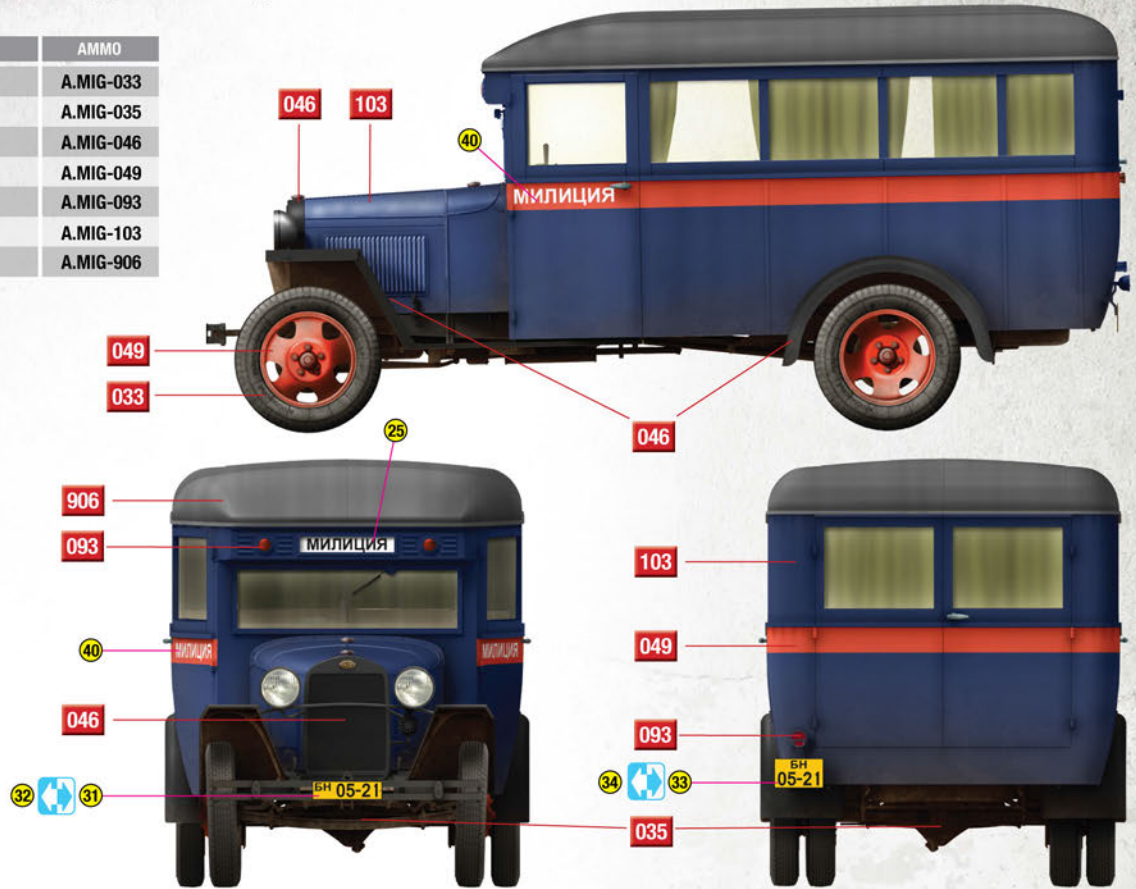

Service buses for construction management №5 (SMU-5), Zaporozhskaya Oblast (Zaporizhzhya), 1958-65.

Служебный автобус, строительно-монтажного управления №5, Запорожская область, 1958-1965 годы.

COLOR NAME	AMMO
Rubber & Tires	A.MIG-033
Dark Tracks	A.MIG-035
Matt Black	A.MIG-046
White	A.MIG-047
Oil Ochre	A.MIG-055
Crystal Red	A.MIG-093
Steel	A.MIG-191

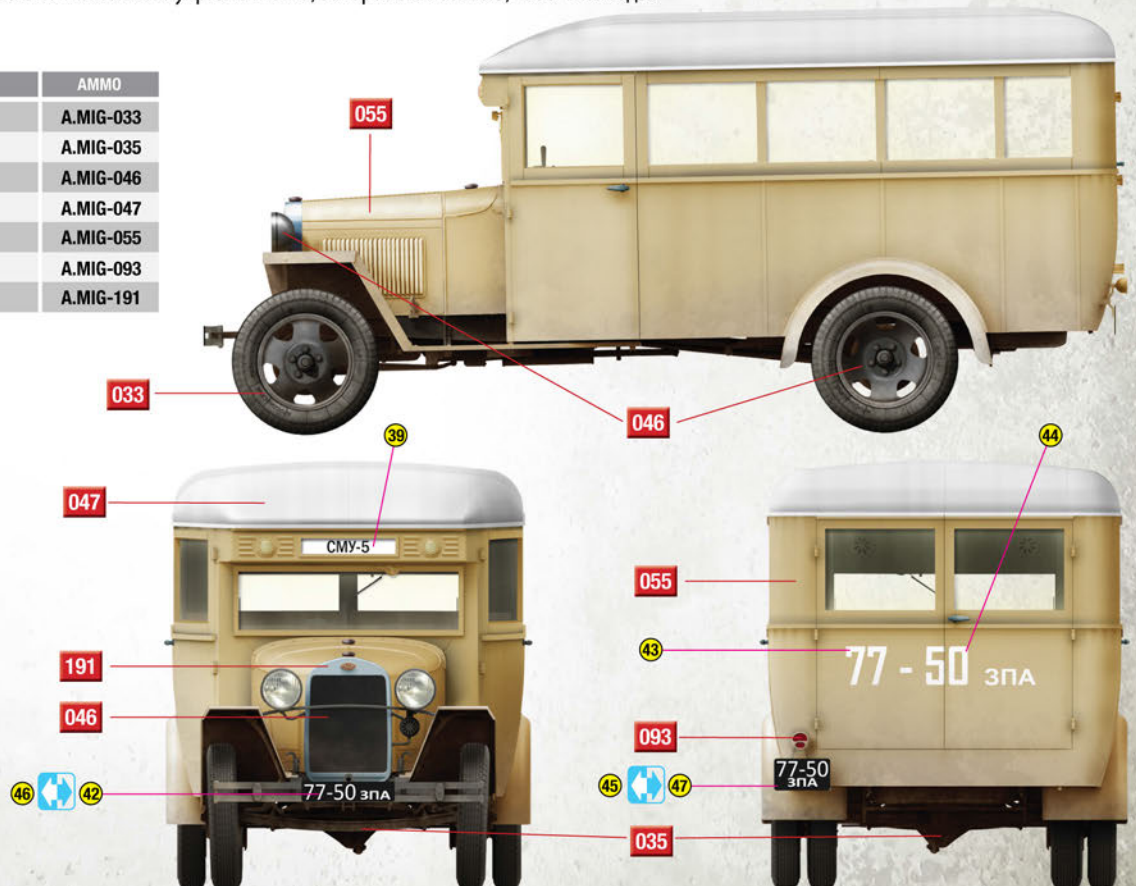

Color info & profiles by



**ATTENTION**

Ne pas utiliser de colle ou de peinture à proximité d'une flamme nue, et adrer la pièce de temps en temps.  
 Pour retirer les pièces hors du cadre, utiliser des ciseaux spéciaux pour maquette le plastique en excès avec un cutter ou une lime.  
 Voir la fin de cette colonne pour la signification des symboles

**ZUR BEACHTUNG**

Kleber und Farbe nicht nahe von offenem Feuer verwenden und das Fenster von Zeit zu Zeit zur Belüftung öffnen.  
 Zum Abschneiden der Teile vom Verbundstück eine Modellierschere verwenden und die überstehenden Plastikteile mit einem Messer oder einer Feile beseitigen.  
 Die Bedeutung der Symbole finden Sie unten in dieser

**УВАГА**

Під час використання клею та фарби, всі роботи проводити у провітрюваному приміщенні по далі від джерела вогню.  
 Деталі відокремлювати від літників ножем або іншим ріжучим інструментом.

Зачистити обліюї місця з'язу за допомогою наждапки та наждакового паперу.

Складення моделей проводити згідно схеми складання. Для зручності складання кожна деталь відзначена номером.

**ATTENZIONE**

Non usare colla e vernice vicino a fiamme esposte, e aprire le finestre di tanto in tanto per cambiare l'aria.  
 Quando si staccano parti del cartello, usare forbici da modellismo e eliminare la plastica in eccesso con un coltello o una lima.  
 Vedere in fondo a questa colonna per le signifi

**ВНИМАНИЕ**

При использовании клея и красок, все работы производить в проветриваемом помещении вдали от источников огня.

Детали отделять от литников ножом или другим режущим инструментом.

Зачистить обліюї места среза при помощи наждапки и наждачной бумаги.

Сборку моделей производить согласно схемы сборки. Для удобства сборки каждая деталь обозначена номером.

**CAUTION**

When you use glue or paint, do not use near open flame, and use in well ventilated room.  
 When you take parts off from the runner frame, use a modeling scissors and trim excess plastic with a cutter or a file.  
 See the bottom of this column for the meaning of symbols.



MAKE 2PCS  
2 TEILE FERTIGEN  
EFFECTUER 2 PIECES  
FAIRE DUE PEZZI  
TEE 2 KPL  
GÖR 2 ST  
ПОВТОРИТЬ ДВА РАЗА  
КІЛЬКІСТЬ РАЗІВ



DO NOT CEMENT  
NICHT KLEBEN  
NE PAS COLLER  
NON INCOLLARE  
EILIMAA  
LIMMAEJ  
НЕ ИСПОЛЬЗОВАТЬ КЛЕЙ  
НЕ КЛЕЙТИ



OPTIONAL  
NÄCH BELIEBEN  
FACULTATIF  
FACOLTATIVO  
VALINNANVARAINEN  
VALSAR  
ВАРИАНТЫ  
ВАРИАНТИ



OPEN HOLE  
ÖFFNEN  
FAIRE UN TROU  
FORO APERTO  
AVAA REIKÄ  
ÖPNÄ HALET  
СДЕЛАТЬ ОТВЕРСТИЕ  
ЗРОБИТИ ОТВІР



REMOVE  
ENTFERNEN  
RETIRER  
SEPARARE  
POISTA  
AVLAGSNA  
ОТРЕЗАТЬ  
ВІДРІЗАТИ



BEND  
BIEGEN  
BITTE  
PLIER S'IL VOUS PLAIT  
PIEGARE  
TAJTA  
BOCKA  
ВЫГНУТИ  
ВИГНУТИ



SCRATCH/BUILD  
AM MEISTEN ZU MACHEN  
FAIRE LE PLUS RENDITI  
TEE ITSE  
GÖR DIG SJÄLV  
СДЕЛАТЬ САМОМУ  
ЗРОБИТИ САМОМУ

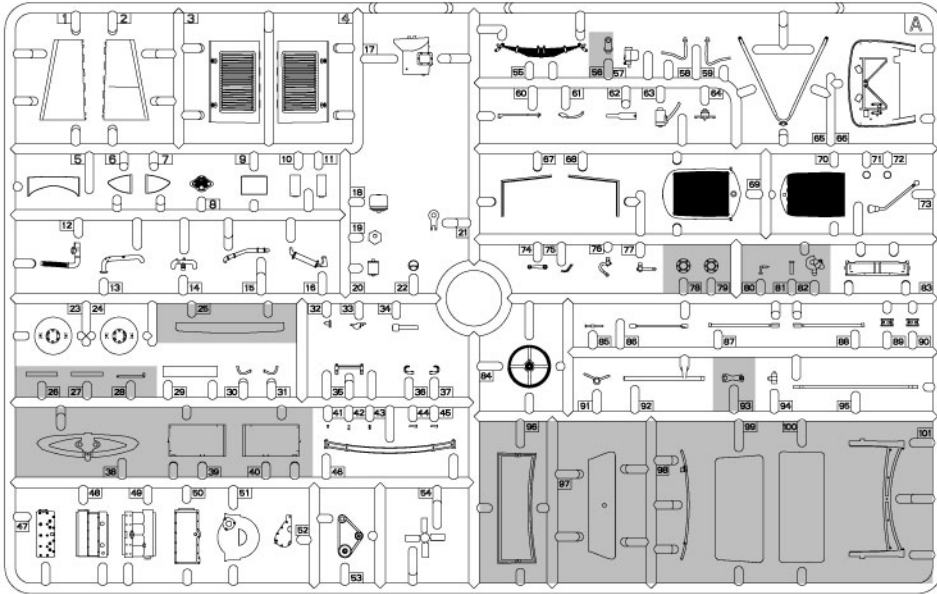
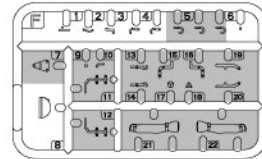
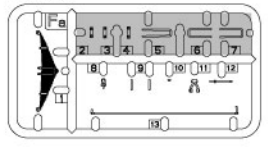
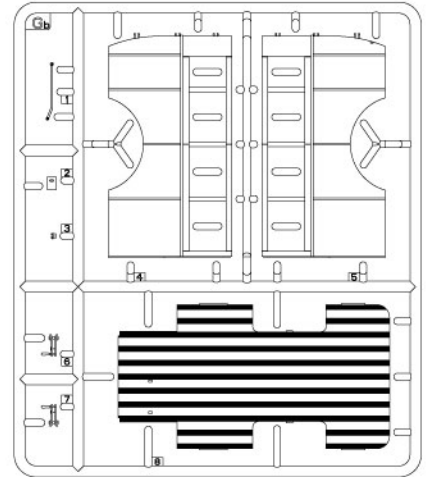
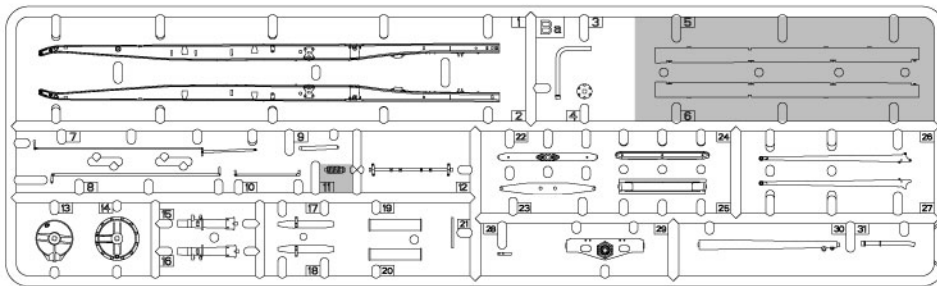
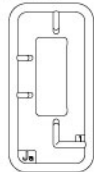
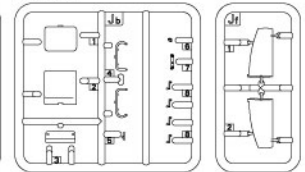
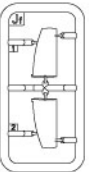
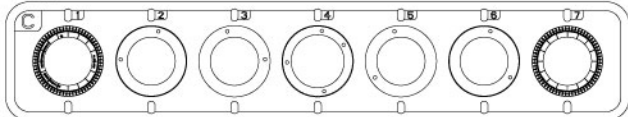
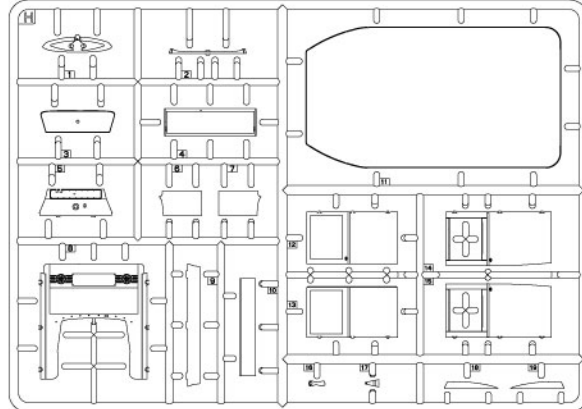
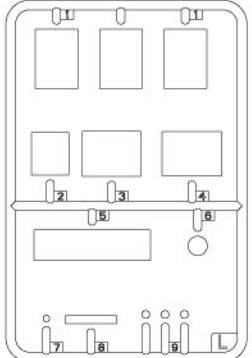
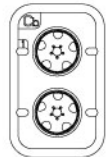
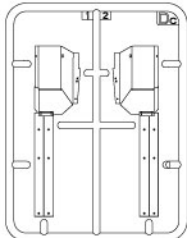
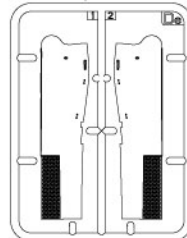
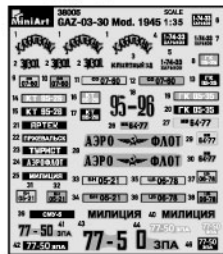
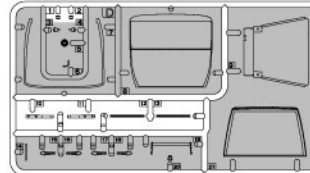
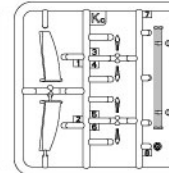
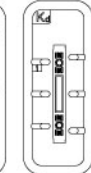
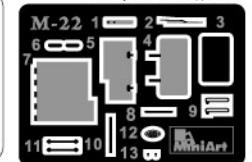

PARTS NOT FOR USE  
TEILE WERDEN NICHT VERWENDET  
NEST PAS UTILISÉ  
PARTI NON PER L'USO  
OSIA EI KÄYTTÄ  
INTE FÖR ANVÄNDNING  
НЕ ИСПОЛЬЗУЕТСЯ  
НЕ ВИКОРИСТОВУЄТЬСЯ

**INSTRUCTION/ІНСТРУКЦІЯ****A****F x2****Fa x2****Gb****Ba****J x8****Ja x2****Jb x2****Jf****C x7****H****L x2****Ca****Cb x2****Cc x2****Cd****Dc Mod. 1945**  
Обр. 1945**De Mod. 1938**  
Обр. 1938**Decal/Деколь****D****Kc****Kd****PE Photo Etched parts**  
Фототравленые детали

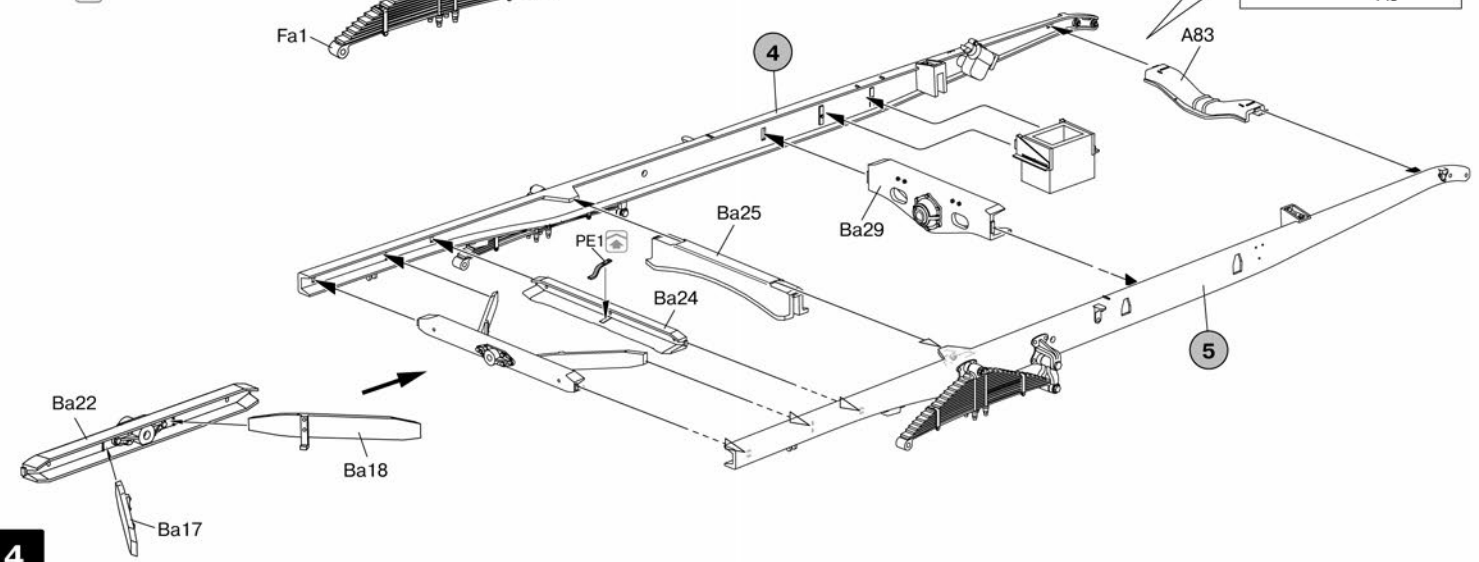
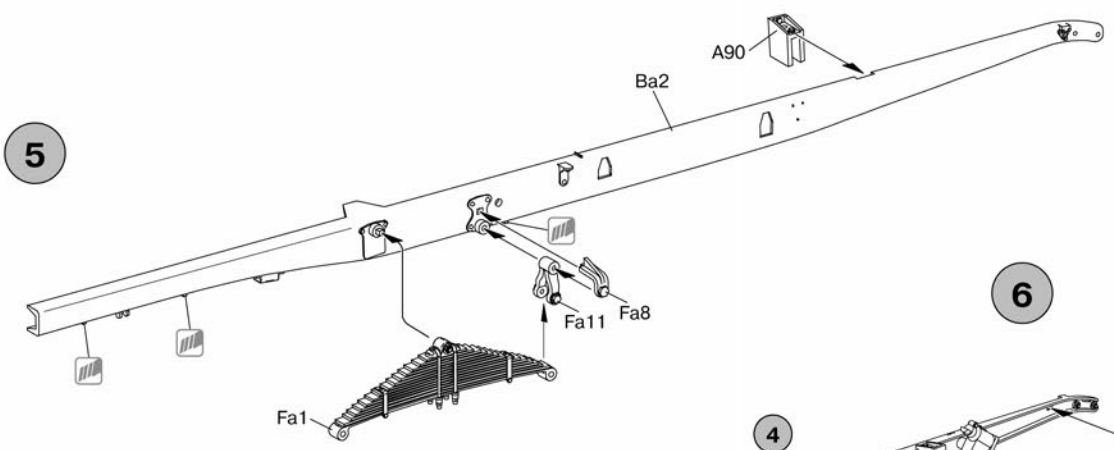
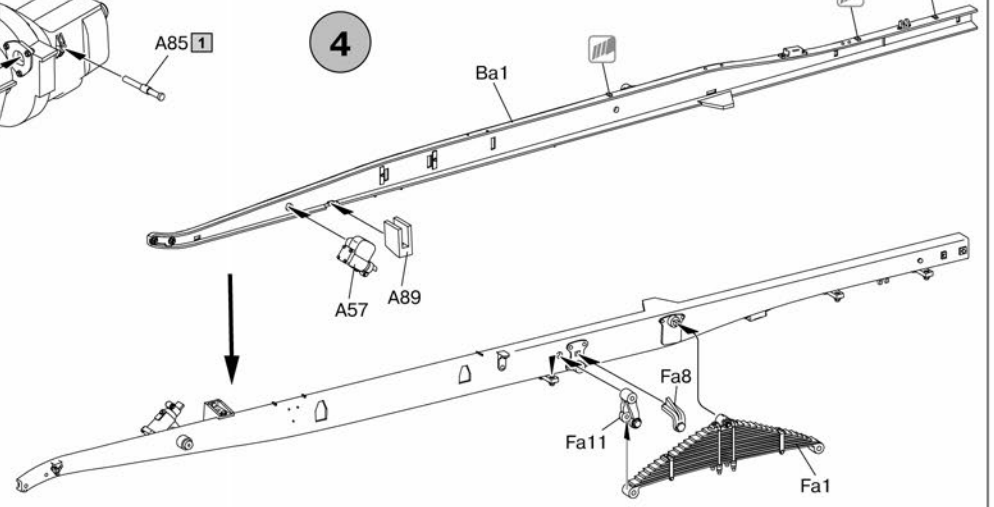
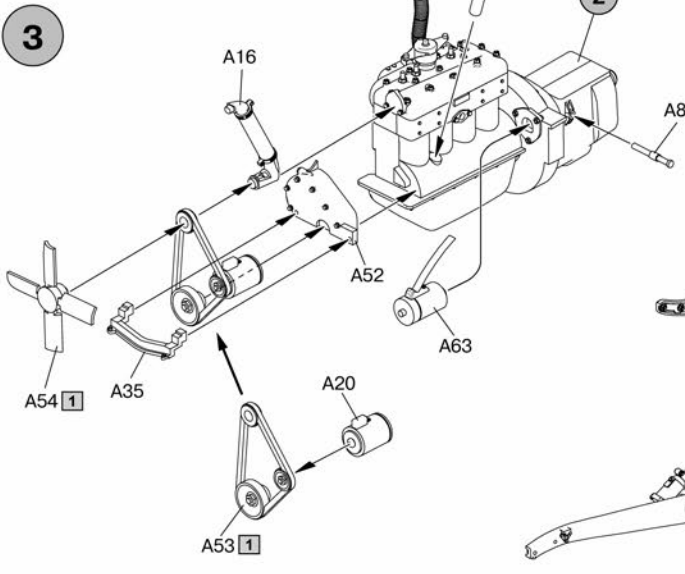
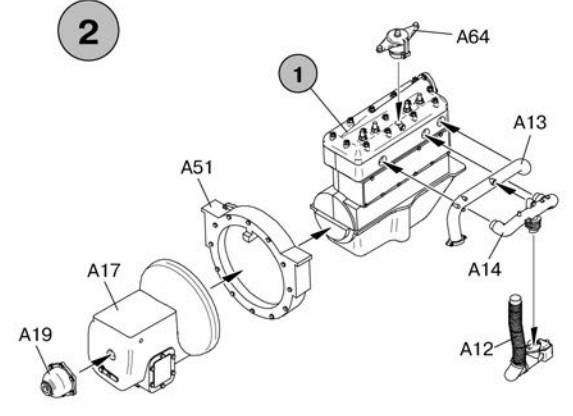
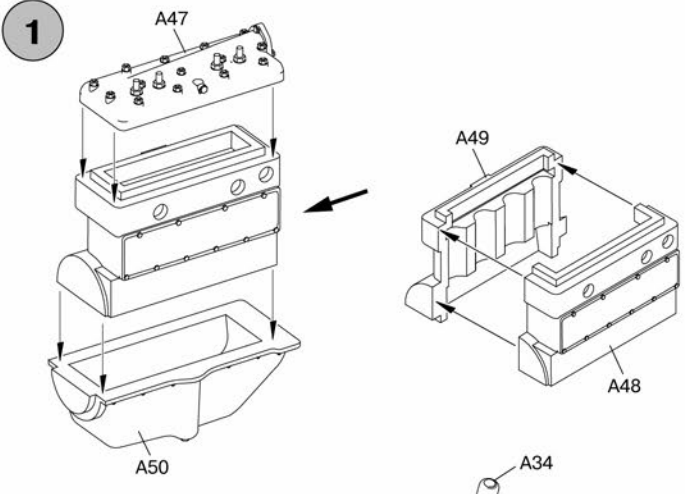

7 x7

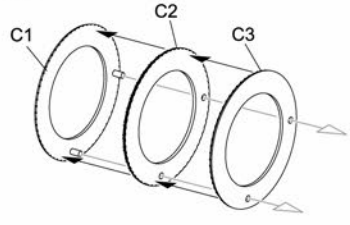

8 x7

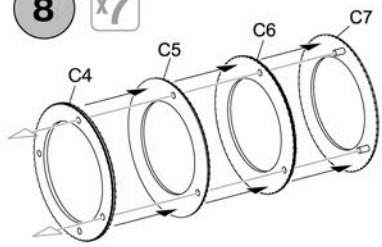

10

9

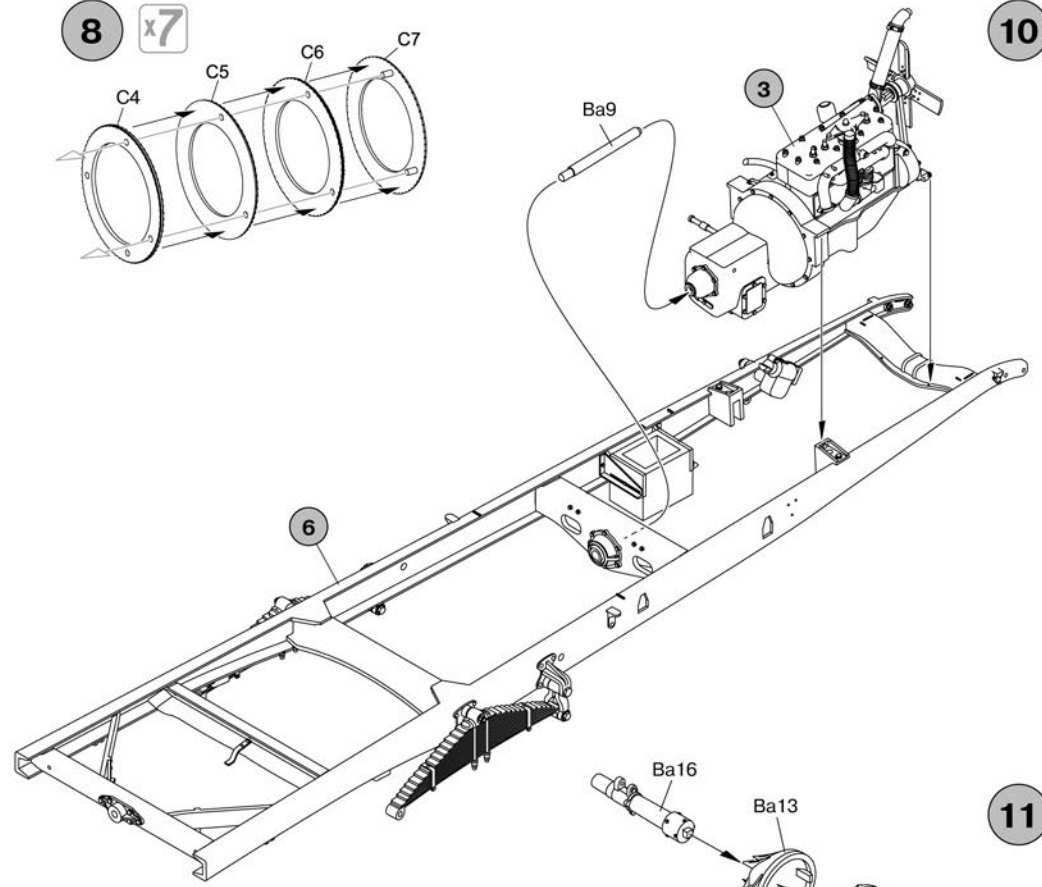
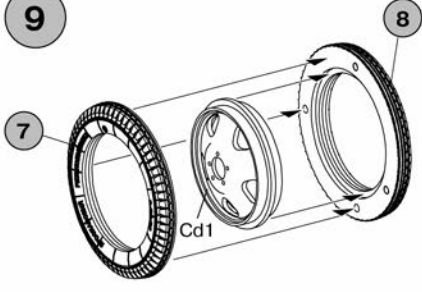

12

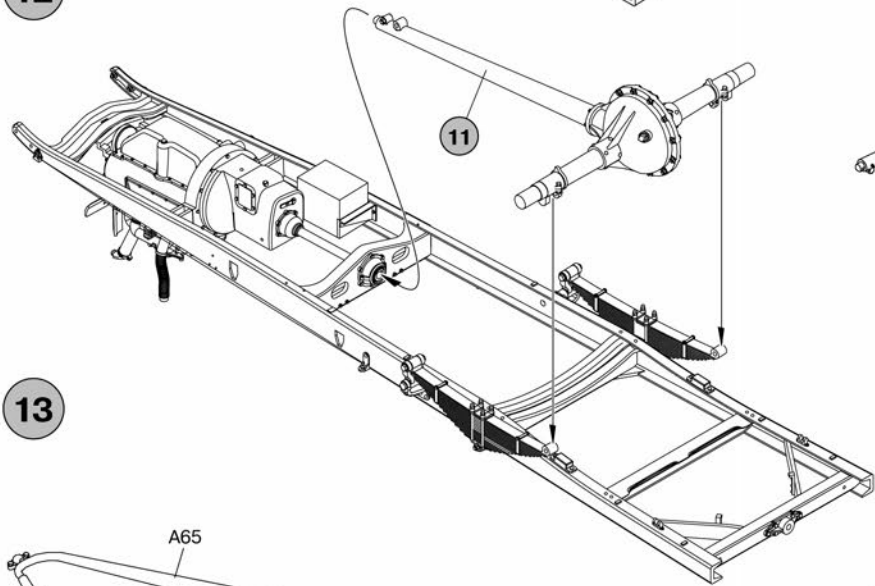

11

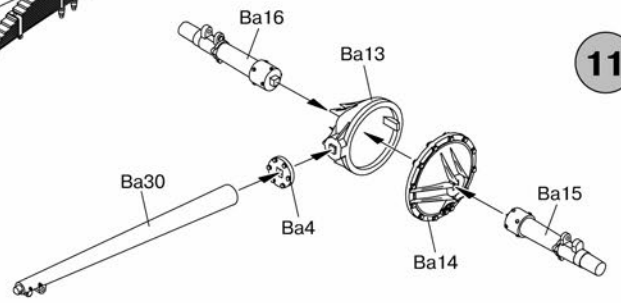

13

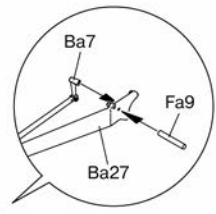
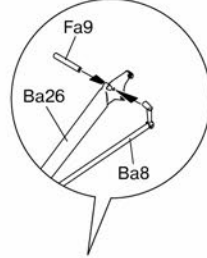
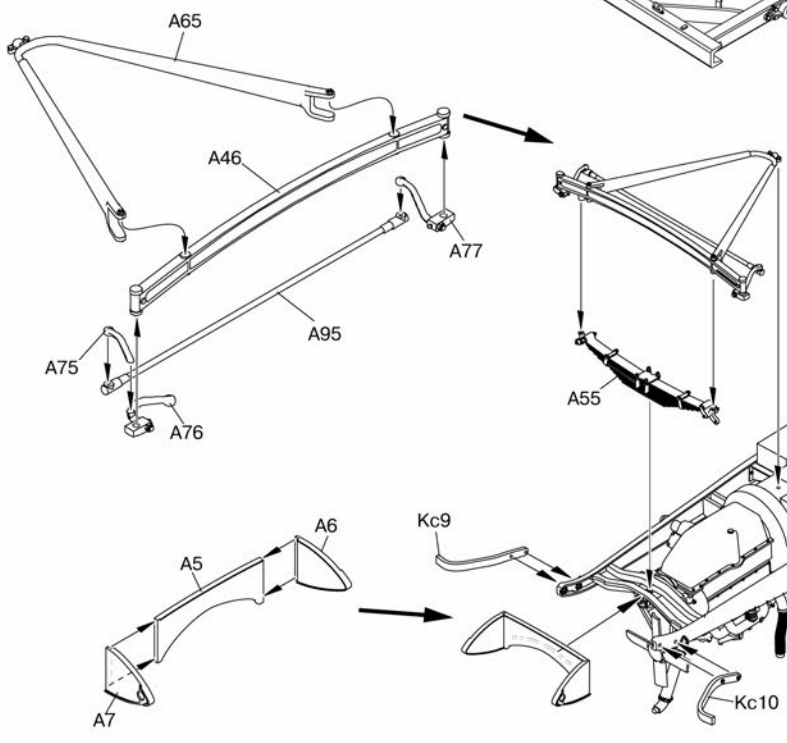

14

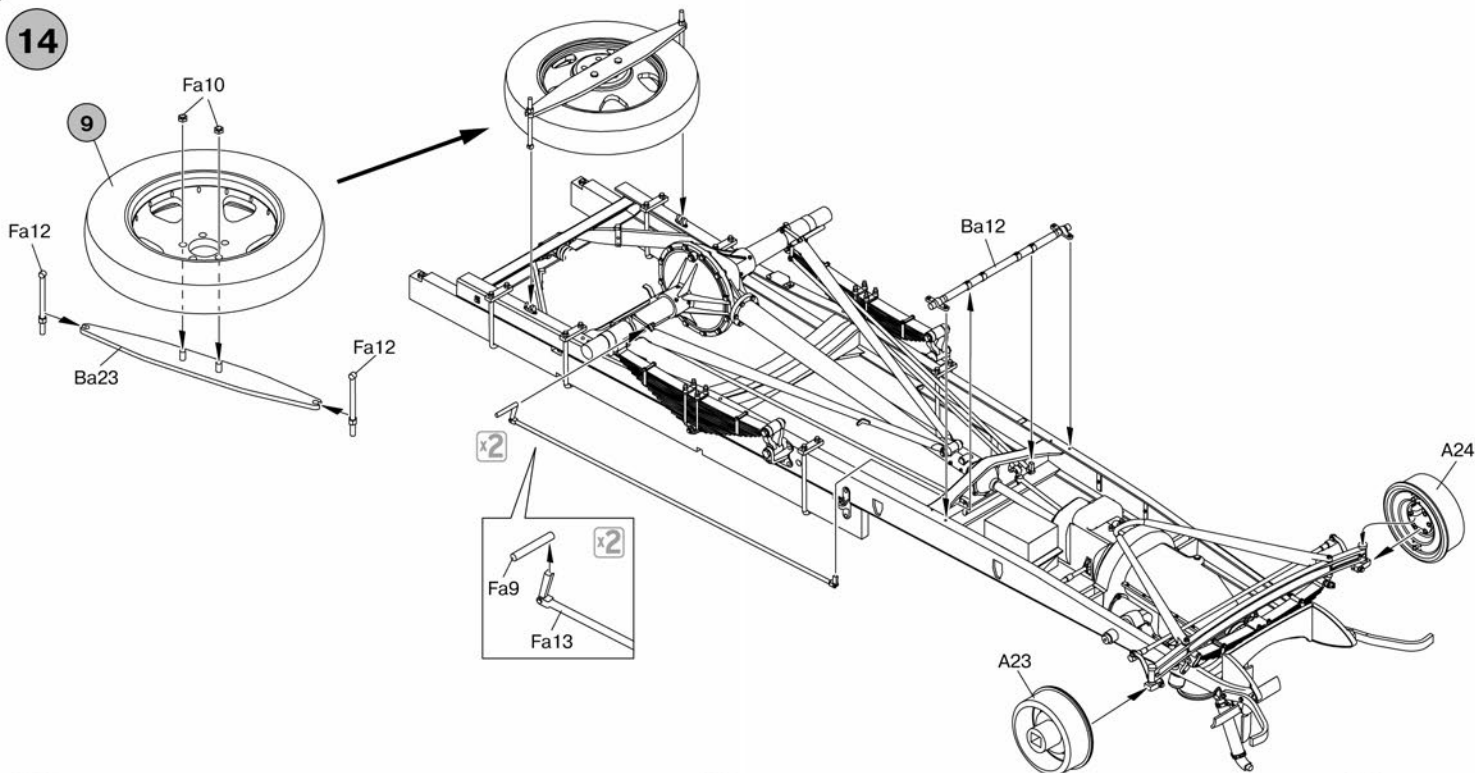

15 x4

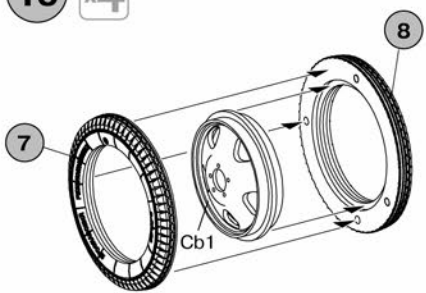

16 x2

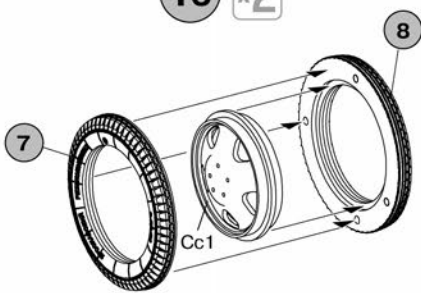

17 x2

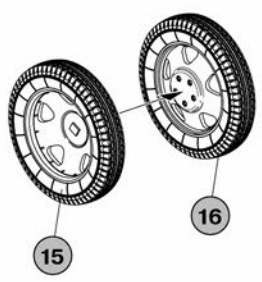

18

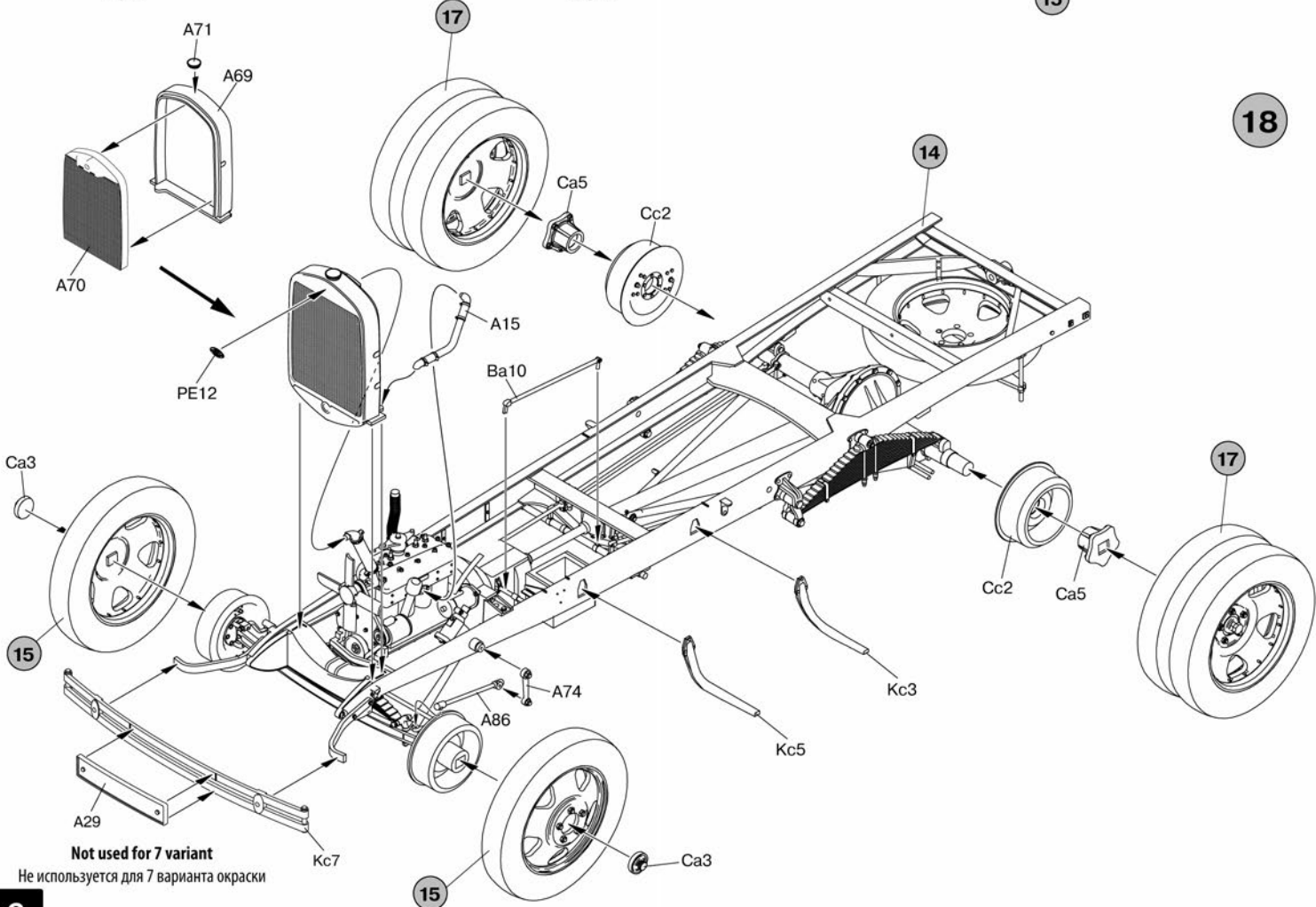

19

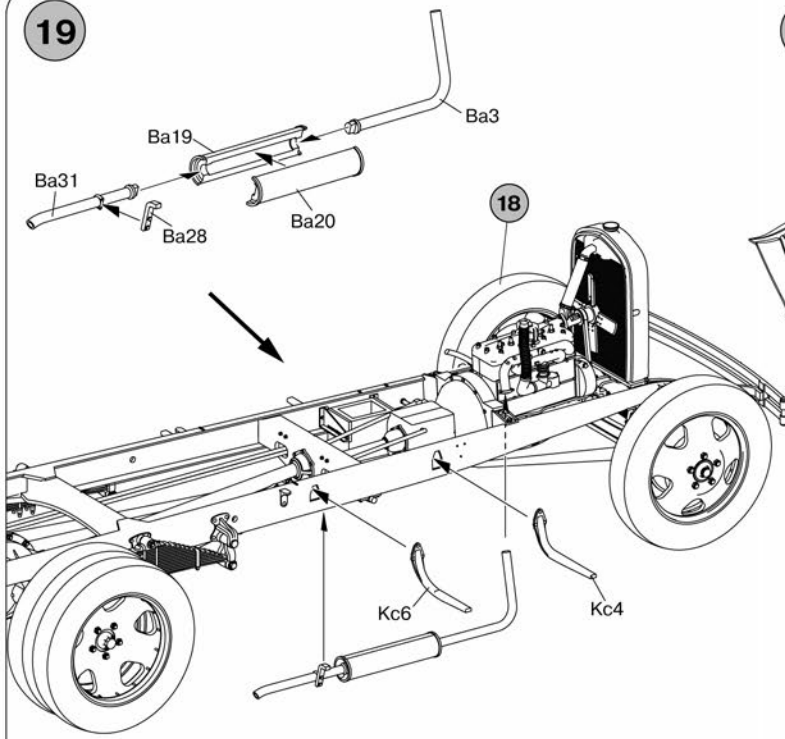

20

Mod. 1938  
06p. 1938

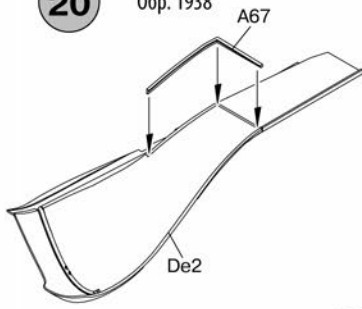

Mod. 1945  
06p. 1945

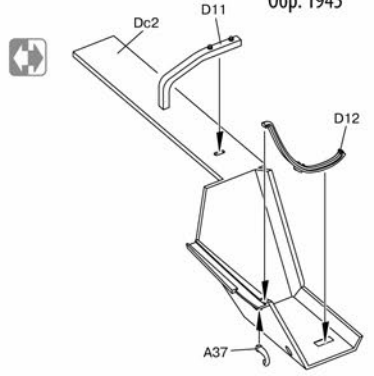

21

Mod. 1938  
06p. 1938

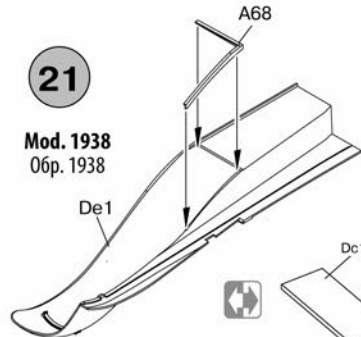

Mod. 1945  
06p. 1945

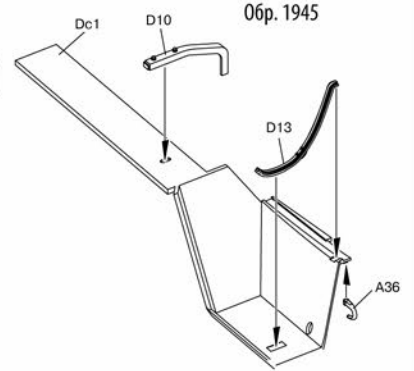

22

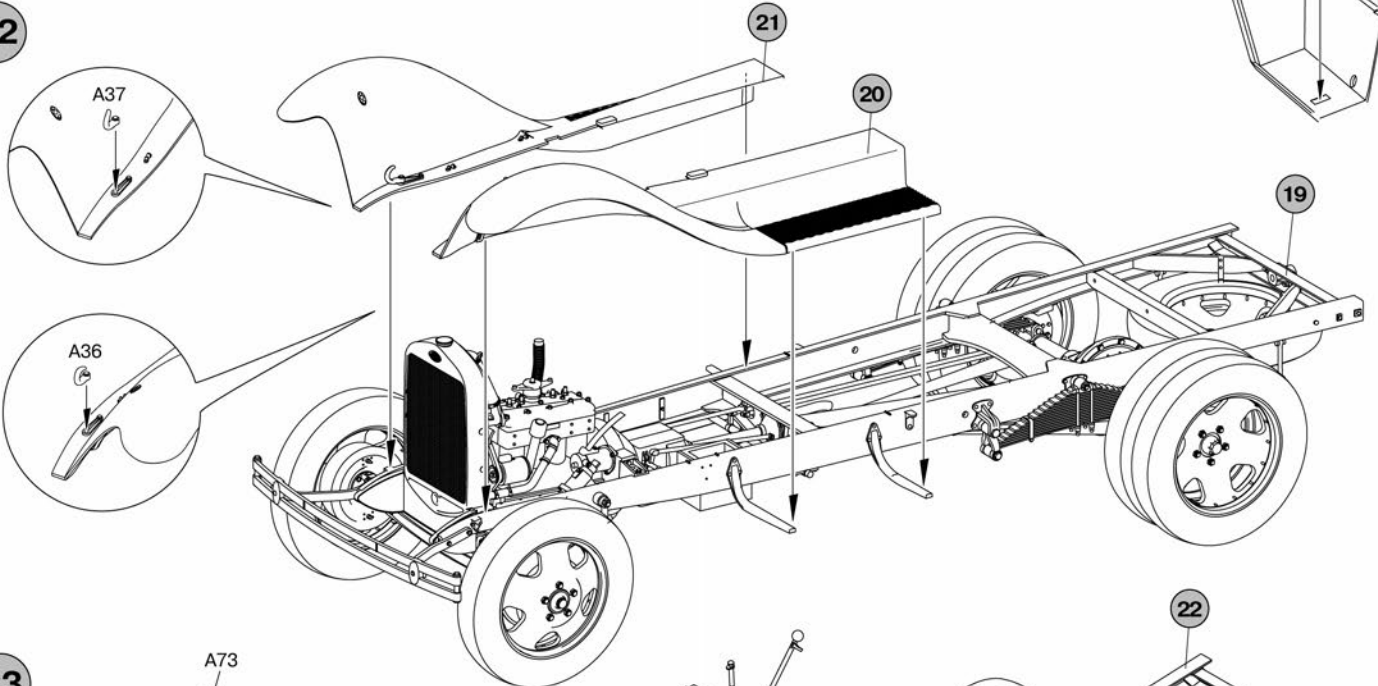

23

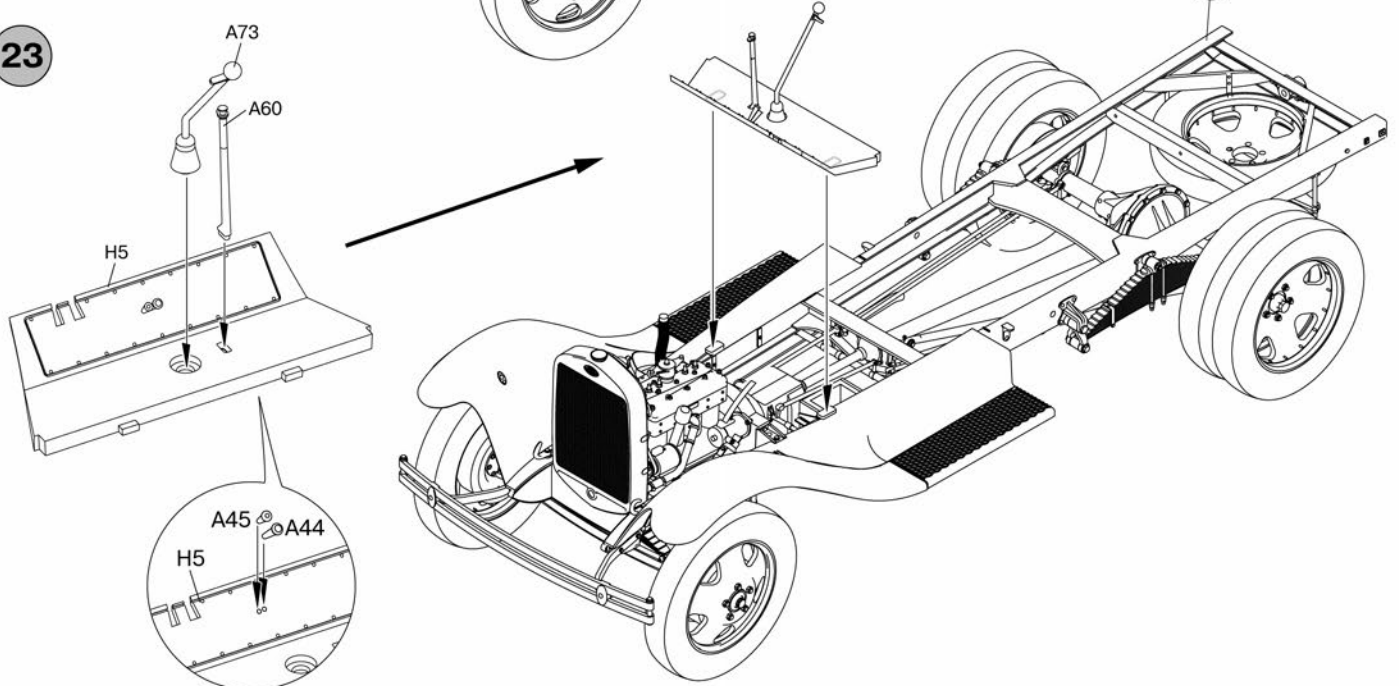

24

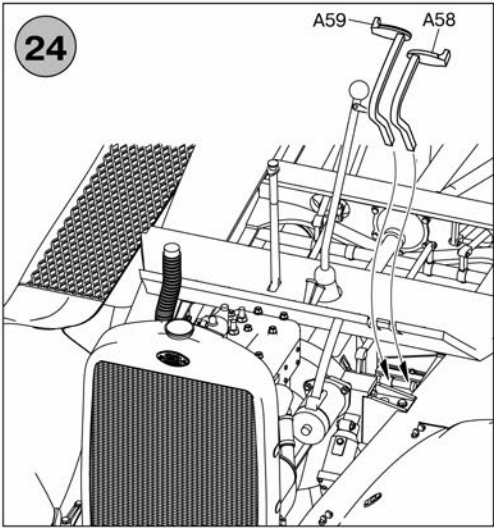

25

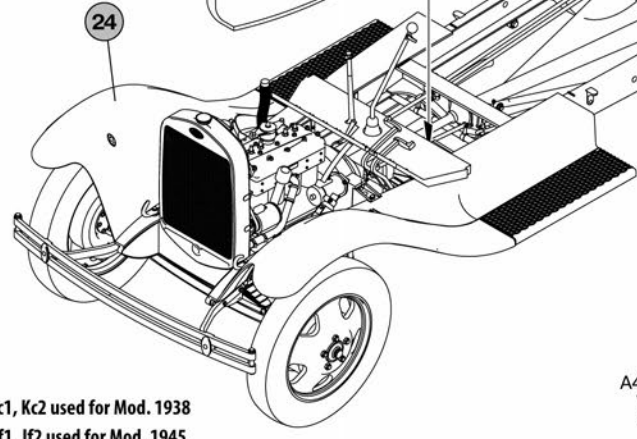
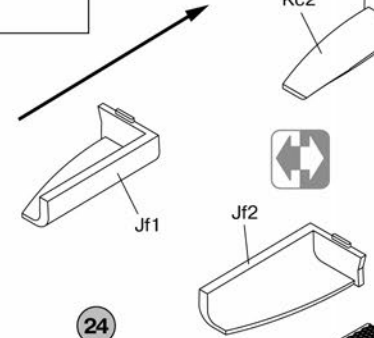
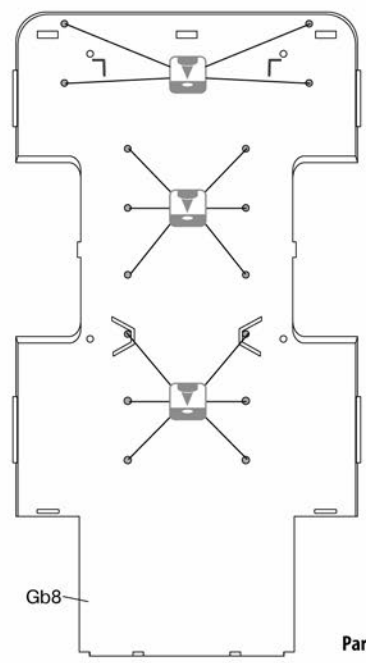
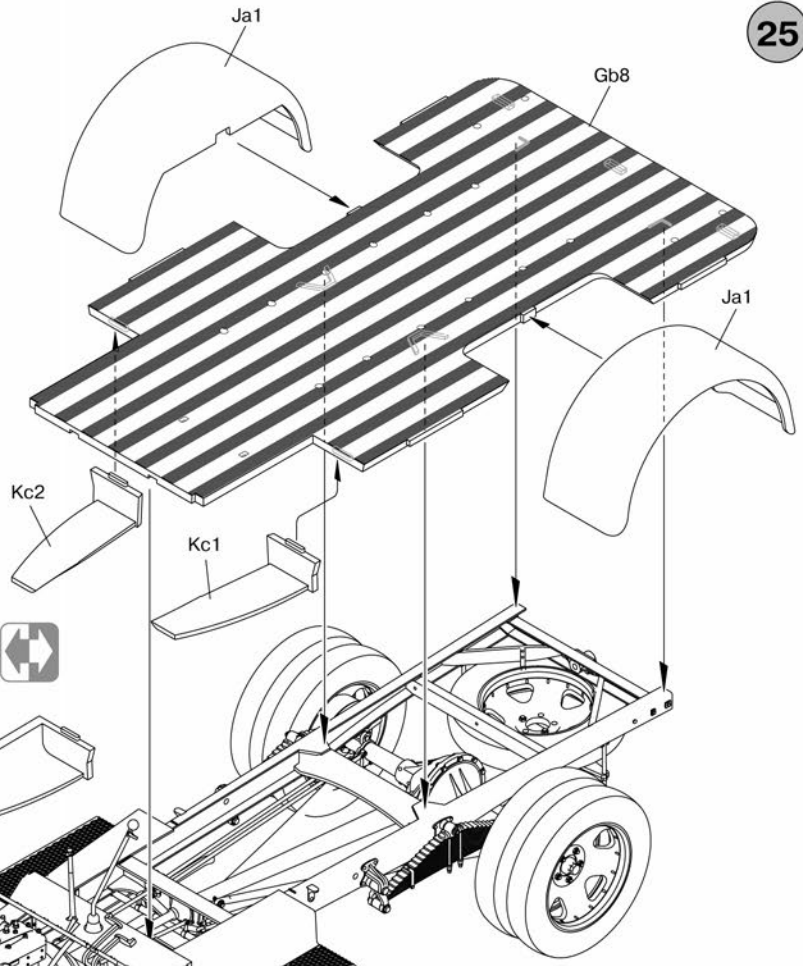

26

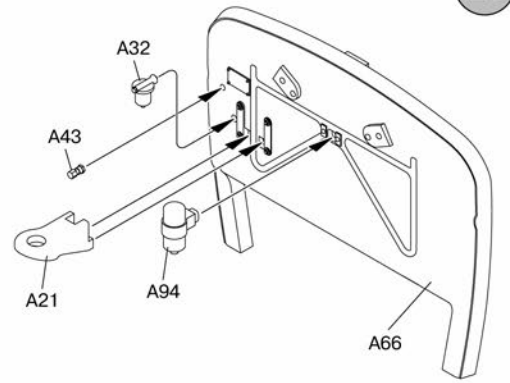

Parts Kc1, Kc2 used for Mod. 1938  
 Parts Jf1, Jf2 used for Mod. 1945

Детали Kc1, Kc2 используются для автобуса обр. 1938 г.  
 Детали Jf1, Jf2 используются для автобуса обр. 1945 г.

27

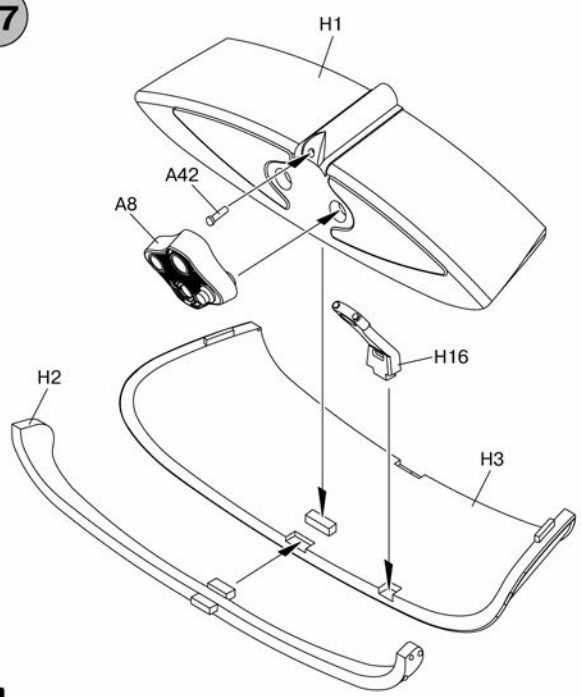

28

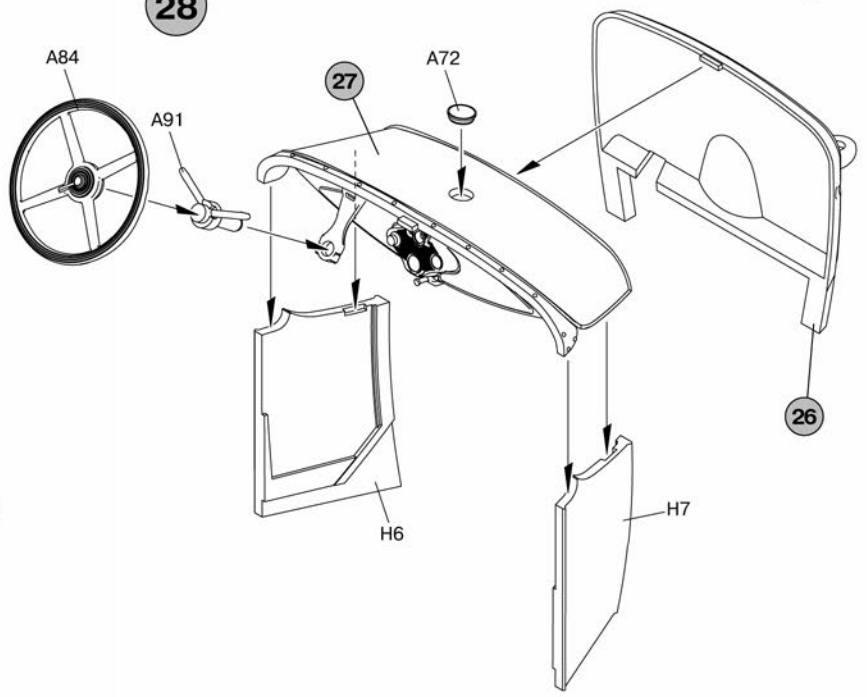



29 x4

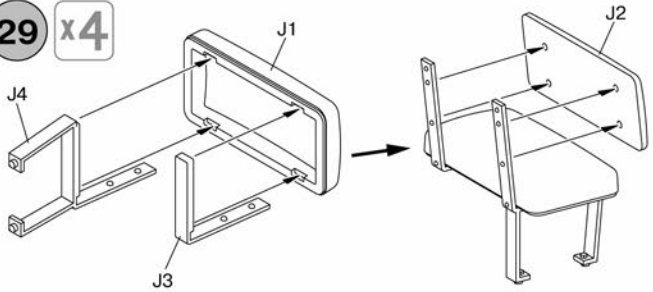

30 x4

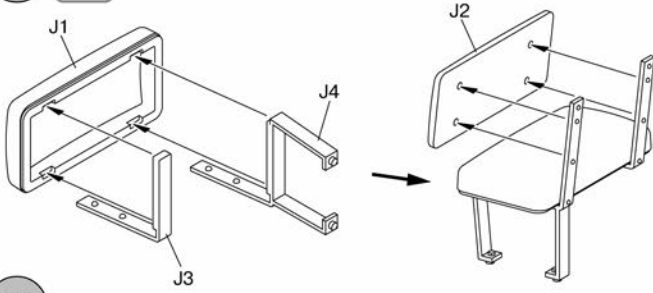

32

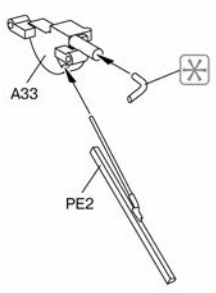

33

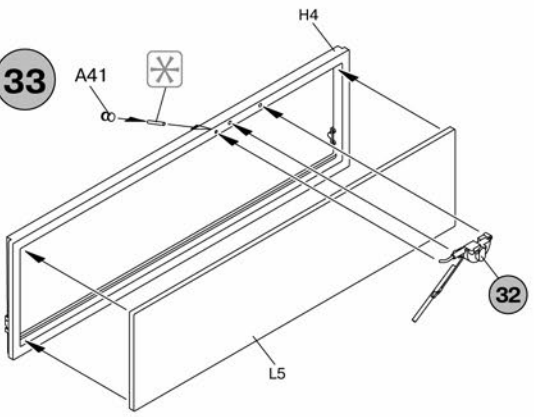

35

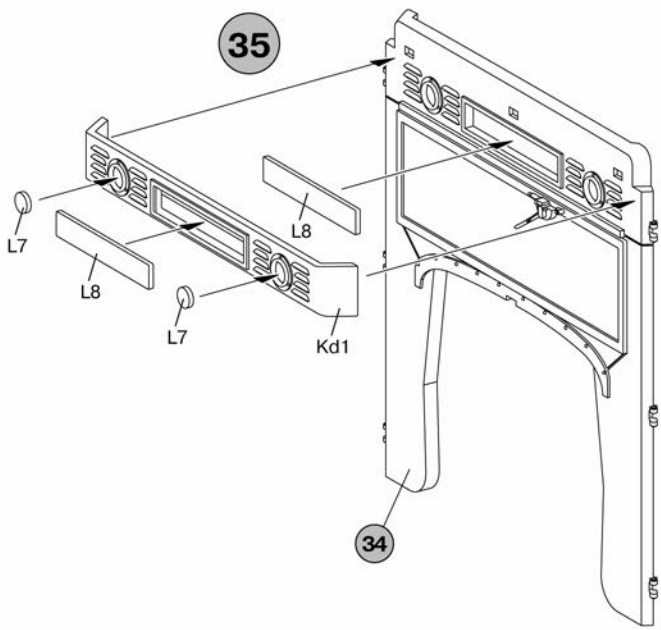

Interior's color is green 4B0  
Интерьер окрашен в зеленый цвет 4B0

31

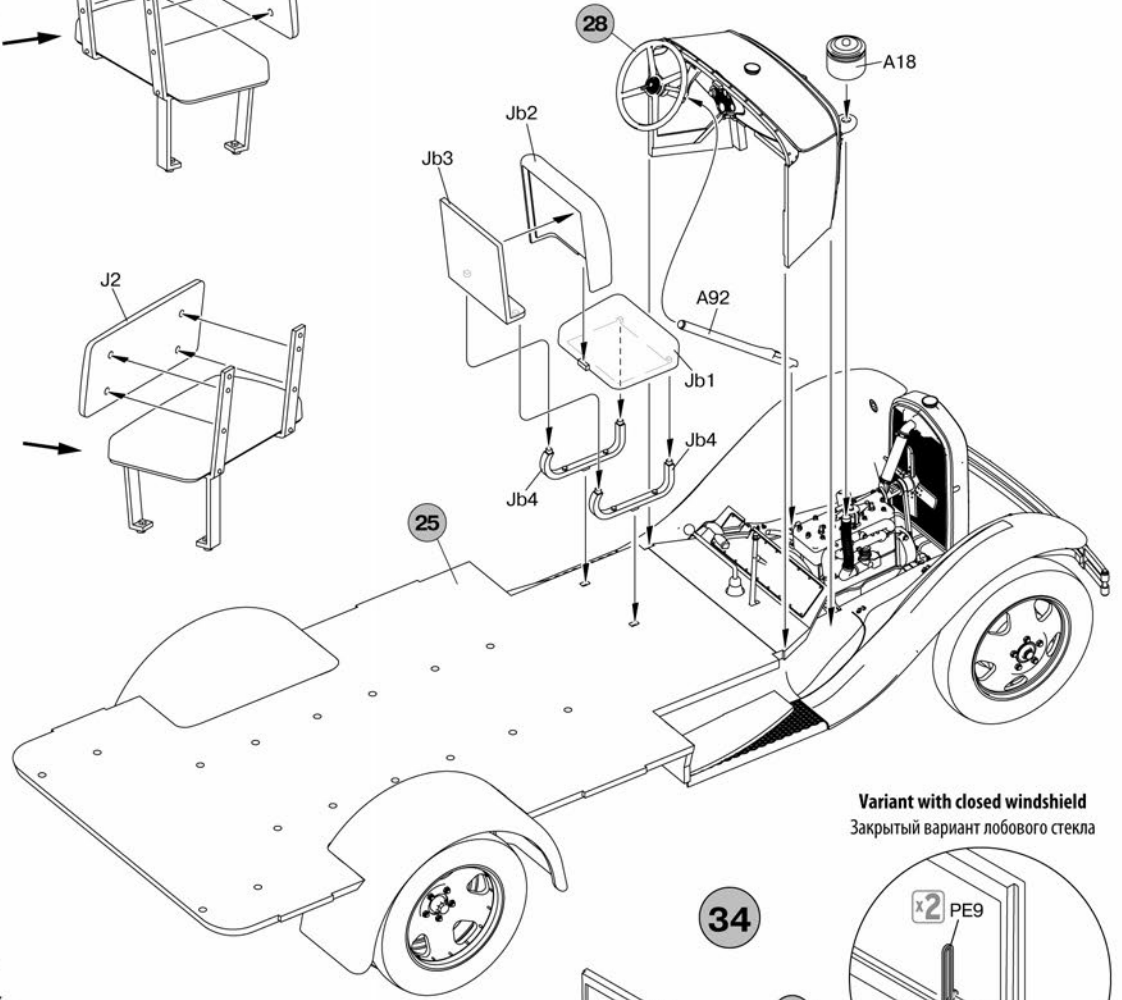

Variant with closed windshield  
Закрытый вариант лобового стекла

34

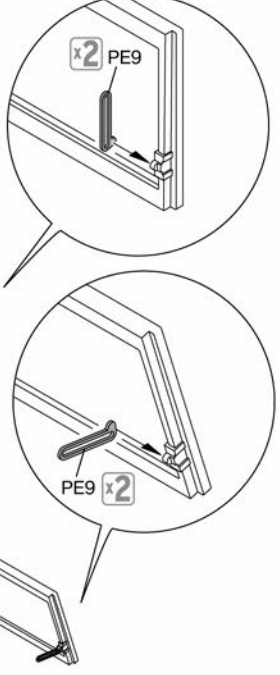

Variant with opened windshield  
Открытый вариант лобового стекла

Variant with opened windshield  
Открытый вариант лобового стекла

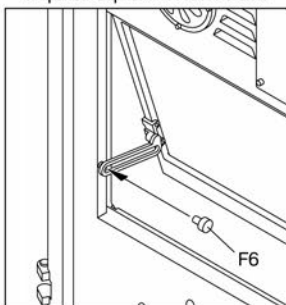

Variant with closed windshield  
Закрытый вариант лобового стекла

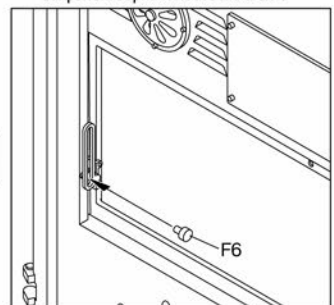

The parts Jb7, Jb6 use only for opened back doors

Детали Jb6, Jb7 используются только для варианта с открытыми задними дверями

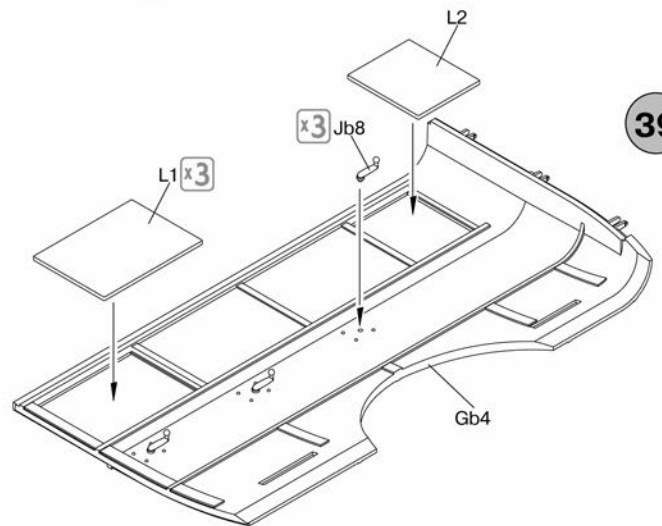
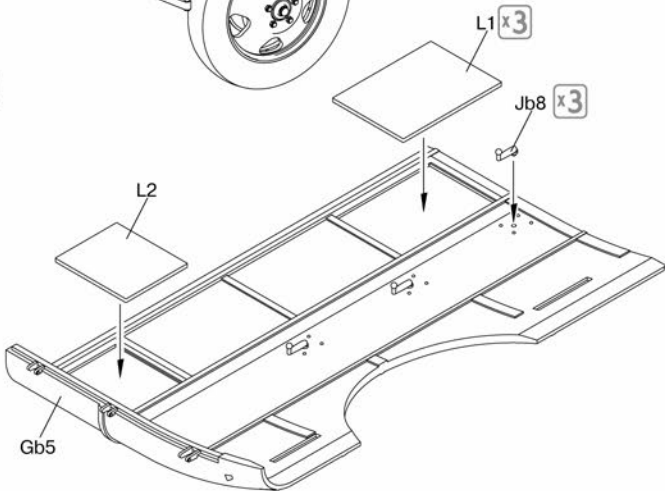
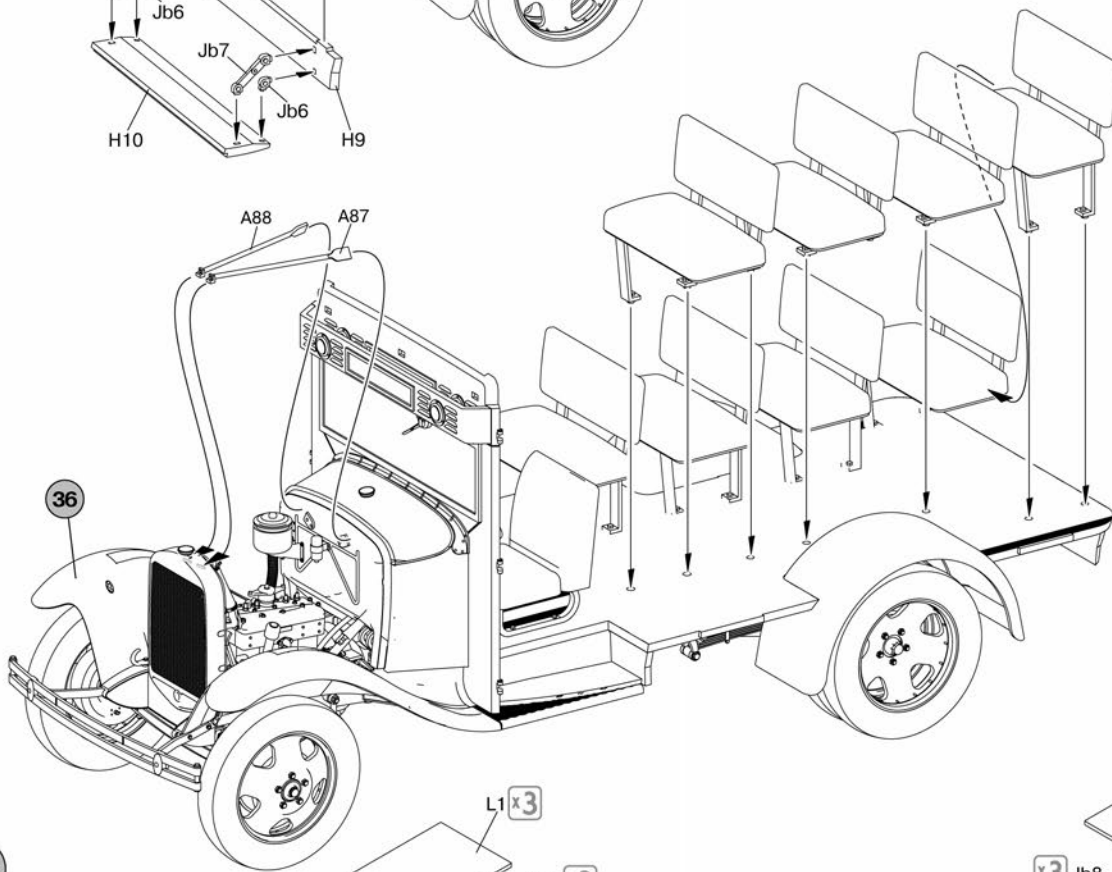
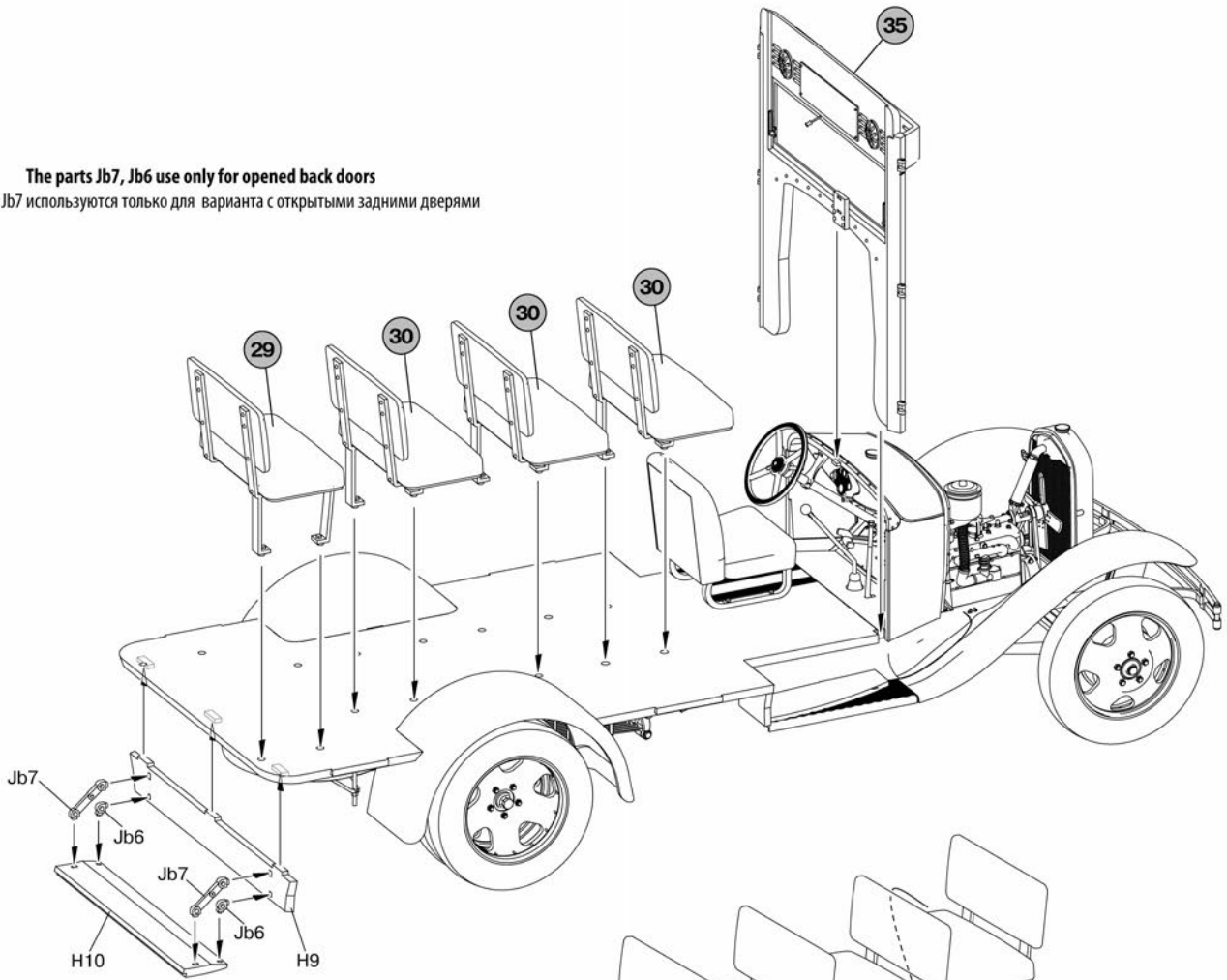

40

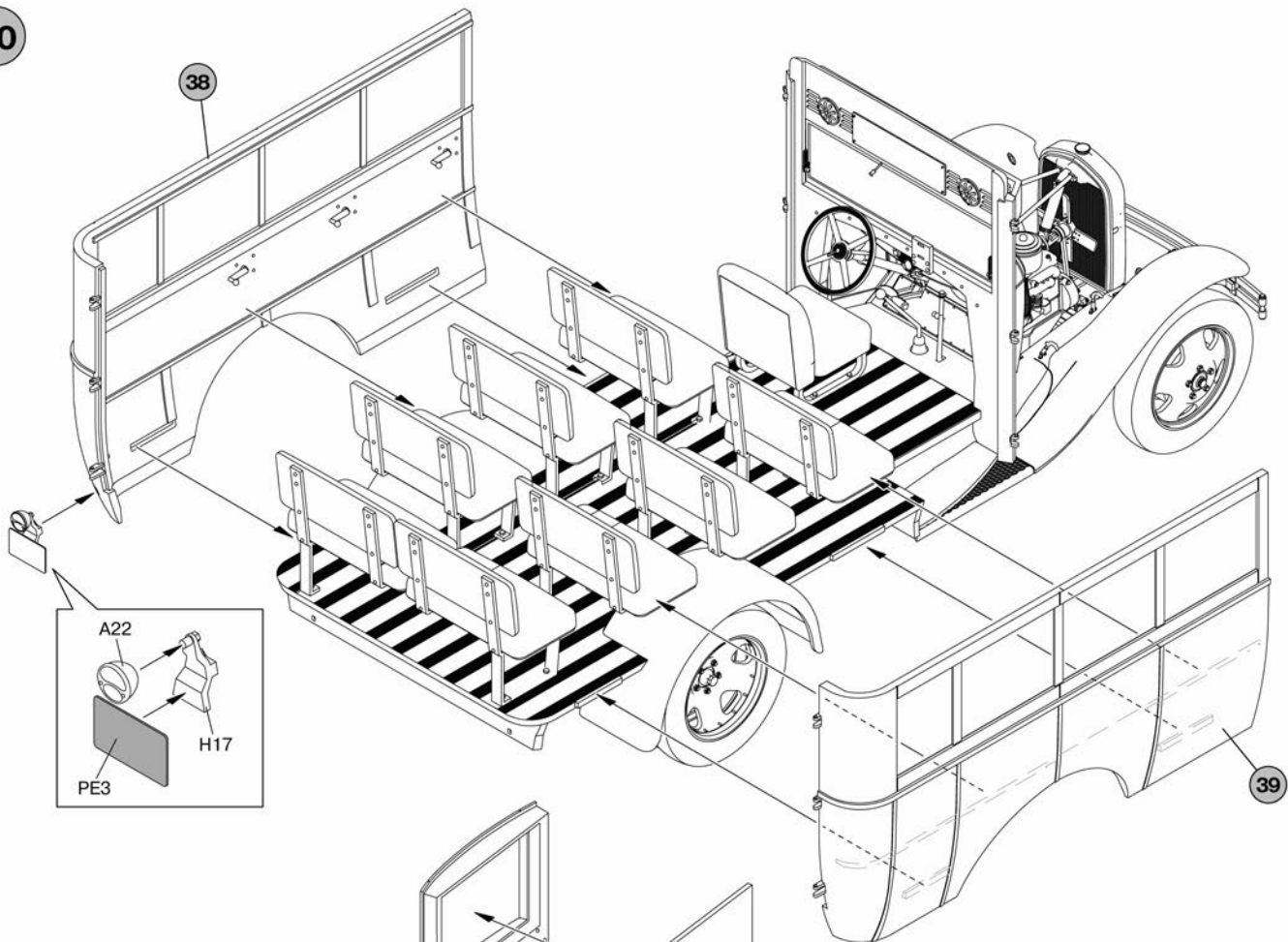

41

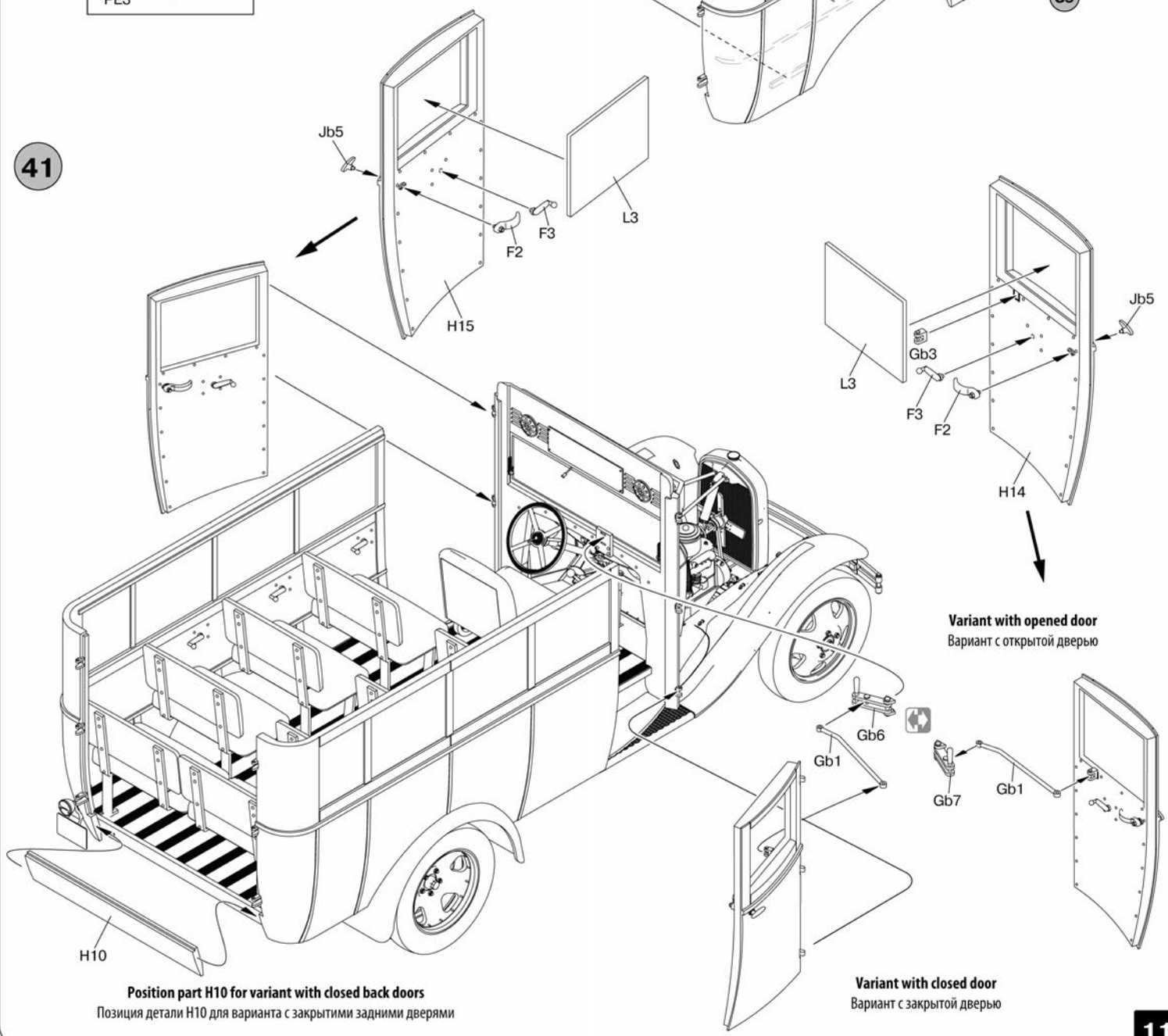

**Position part H10 for variant with closed back doors**  
 Позиция детали H10 для варианта с закрытыми задними дверями

**Variant with opened door**  
 Вариант с открытой дверью

**Variant with closed door**  
 Вариант с закрытой дверью

42

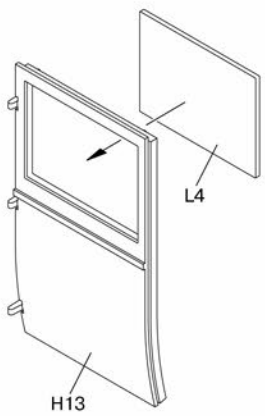

43

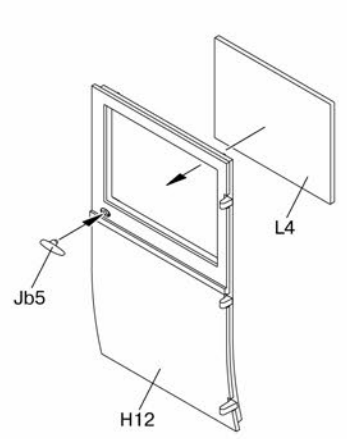

44

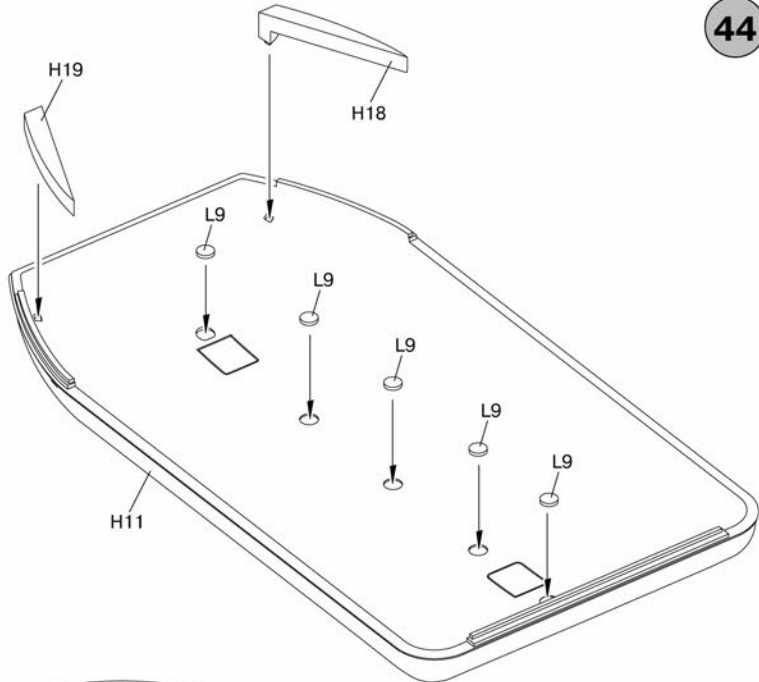

45

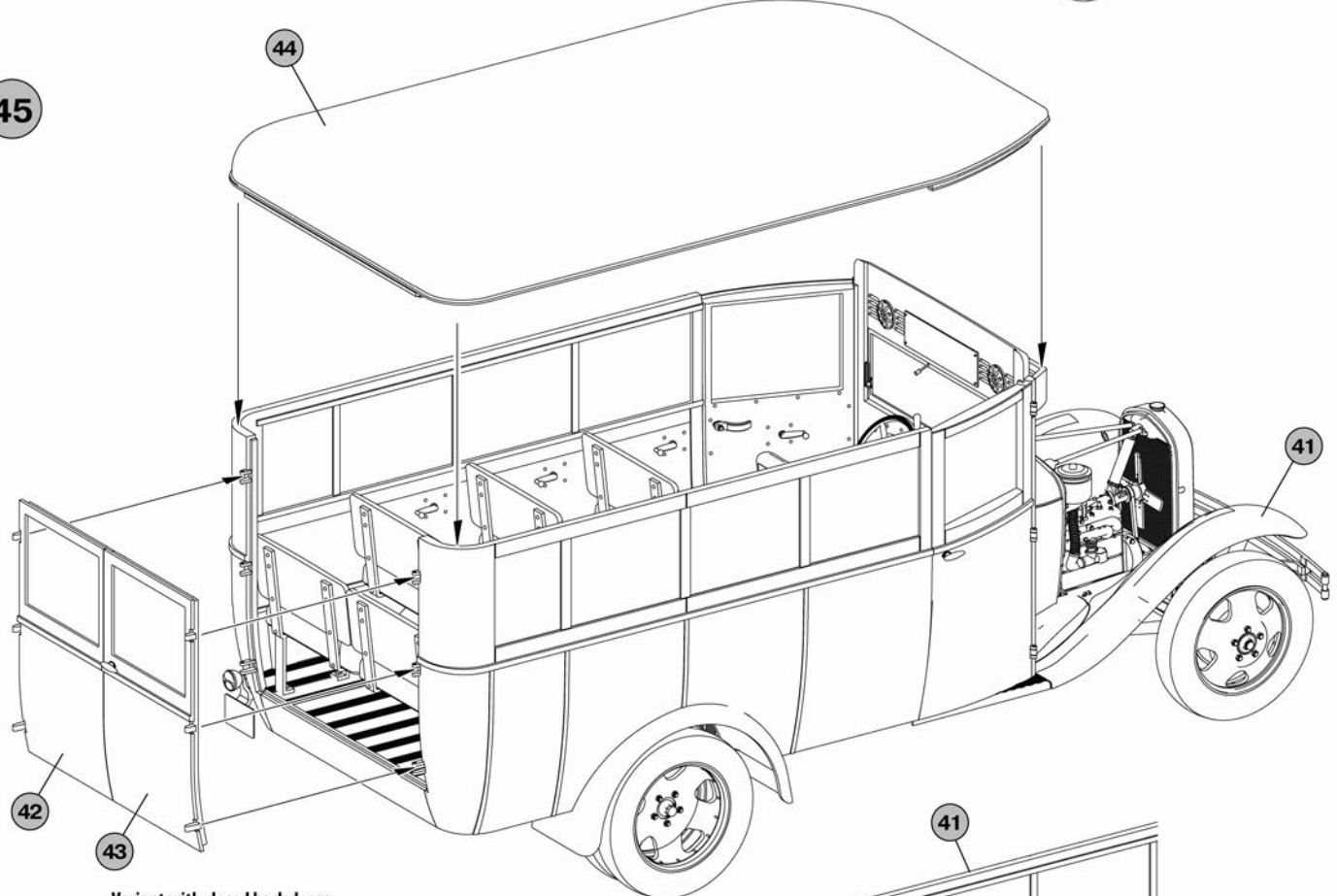

**Variant with closed back doors**  
 Вариант с закрытыми задними дверями



**Variant with opened back doors**  
 Вариант с открытыми задними дверями

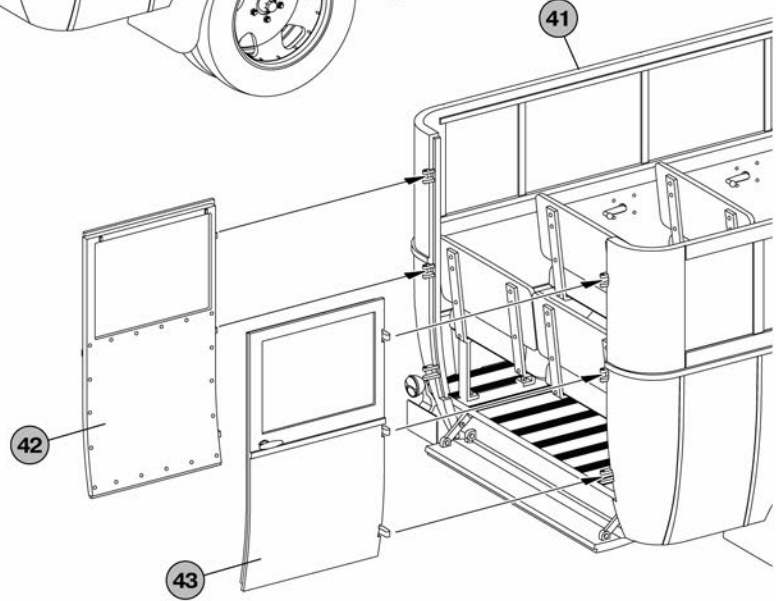

for variant with closed cover  
для варианта с закрытым капотом



for variant with opened cover  
для варианта с открытым капотом

for variant with opened cover  
для варианта с открытым капотом



for variant with closed cover  
для варианта с закрытым капотом

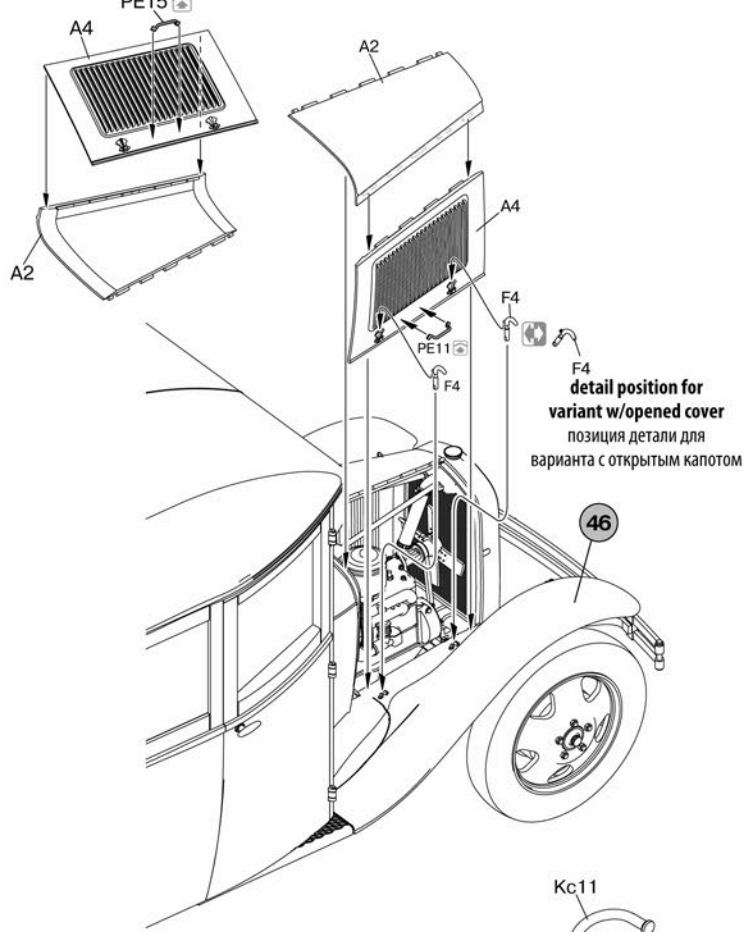
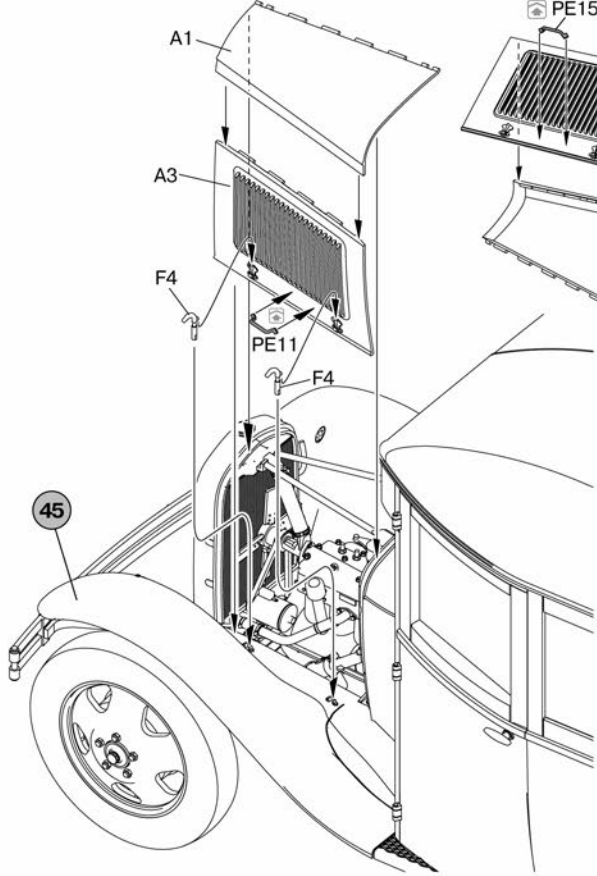

Parts D1, D2 use  
for variant GAZ-03-30 Mod.1945  
Детали D1, D2 используются  
для варианта обр. 1945 года.

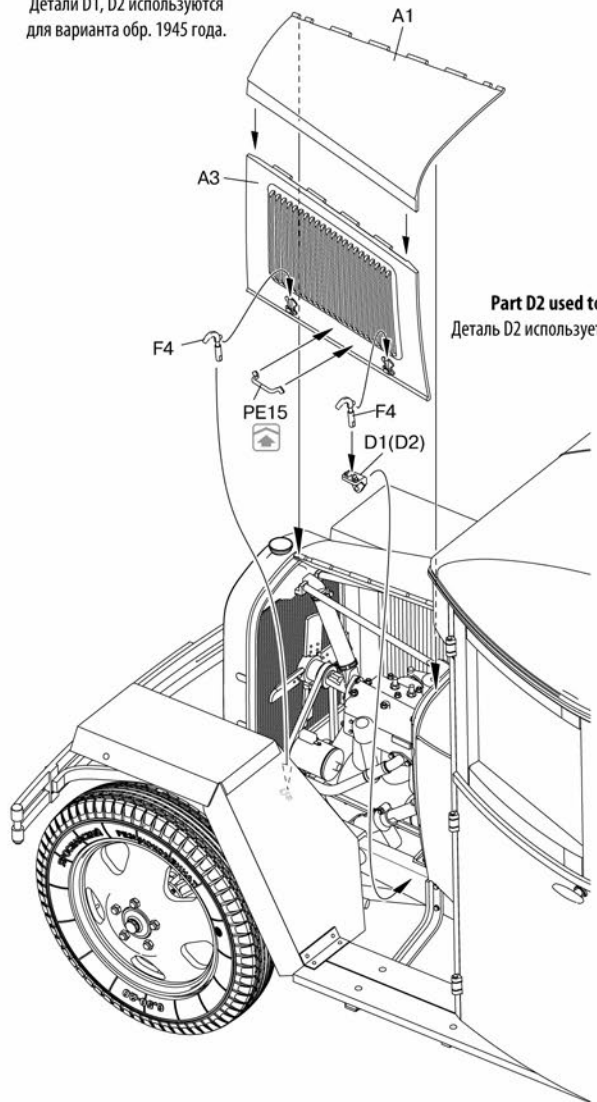

Part PE4 used only for 7 variant  
of painting  
Деталь PE4 используется только  
для 7 варианта окраски

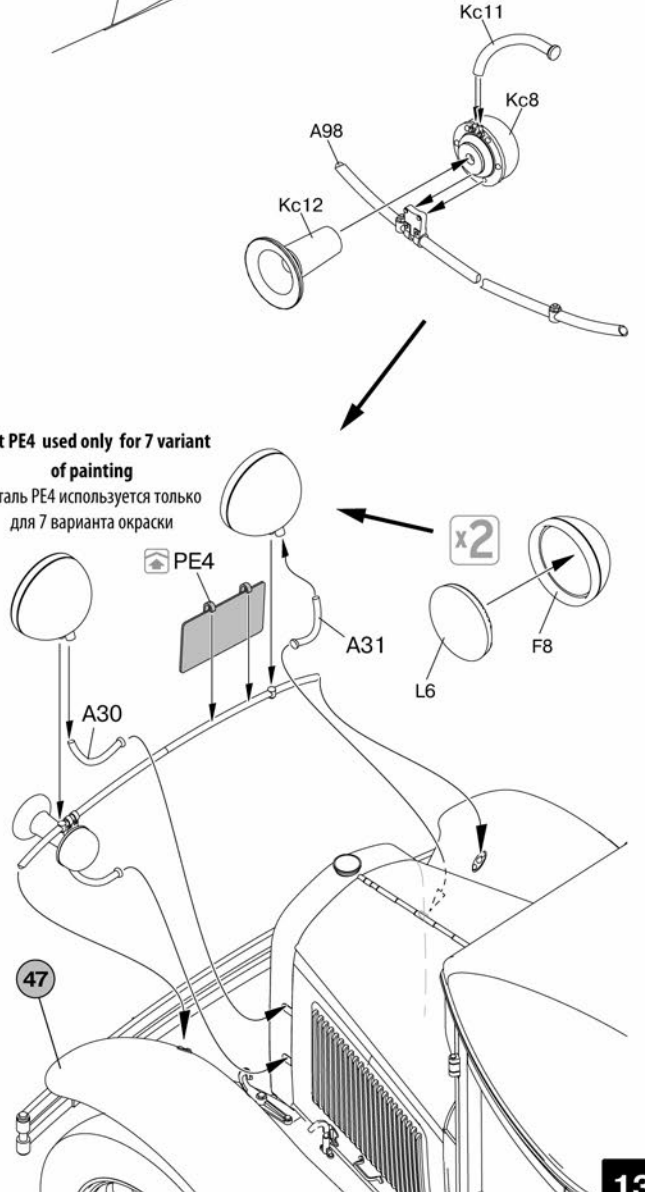

**Service bus for tourist camp "Sochi", Sochi, 1951.**

Служебный автобус туристической базы «Сочи», Сочи, 1951 год.

COLOR NAME	AMMO
Resedagrün	A.MIG-003
Rubber & Tires	A.MIG-033
Dark Tracks	A.MIG-035
Matt Black	A.MIG-046
White	A.MIG-047
French Blue	A.MIG-062
Crystal Red	A.MIG-093

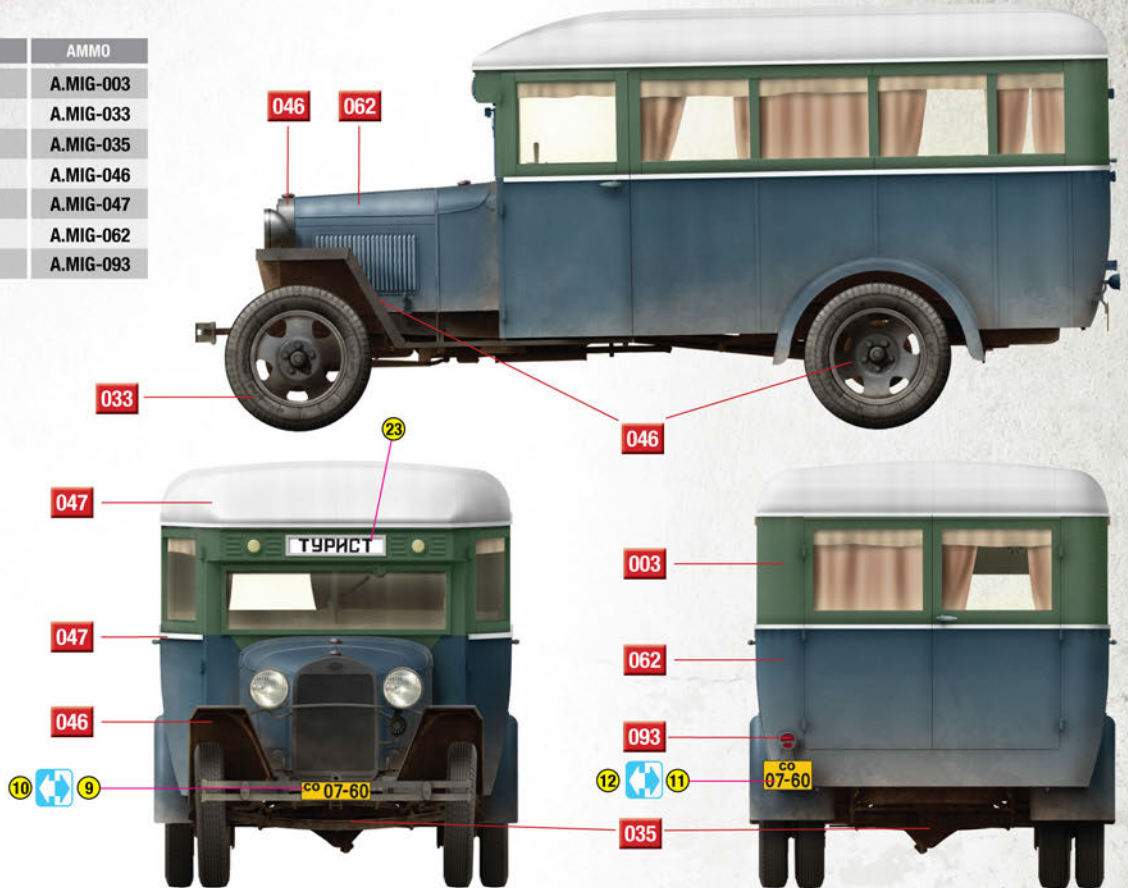

**A regular-route bus, town of Przhevalsk (now Karakol), Issyk-Kul region, Kyrgyz Soviet Socialist Republic, 1946-58.**

Рейсовый автобус Пржевальского автобусного парка, Пржевальск, Исык-Кульская область, Киргизская ССР, 1946-1958 годы.

COLOR NAME	AMMO
Resedagrün	A.MIG-003
Rubber & Tires	A.MIG-033
Dark Tracks	A.MIG-035
Matt Black	A.MIG-046
White	A.MIG-047
Oil Ochre	A.MIG-055
Crystal Red	A.MIG-093

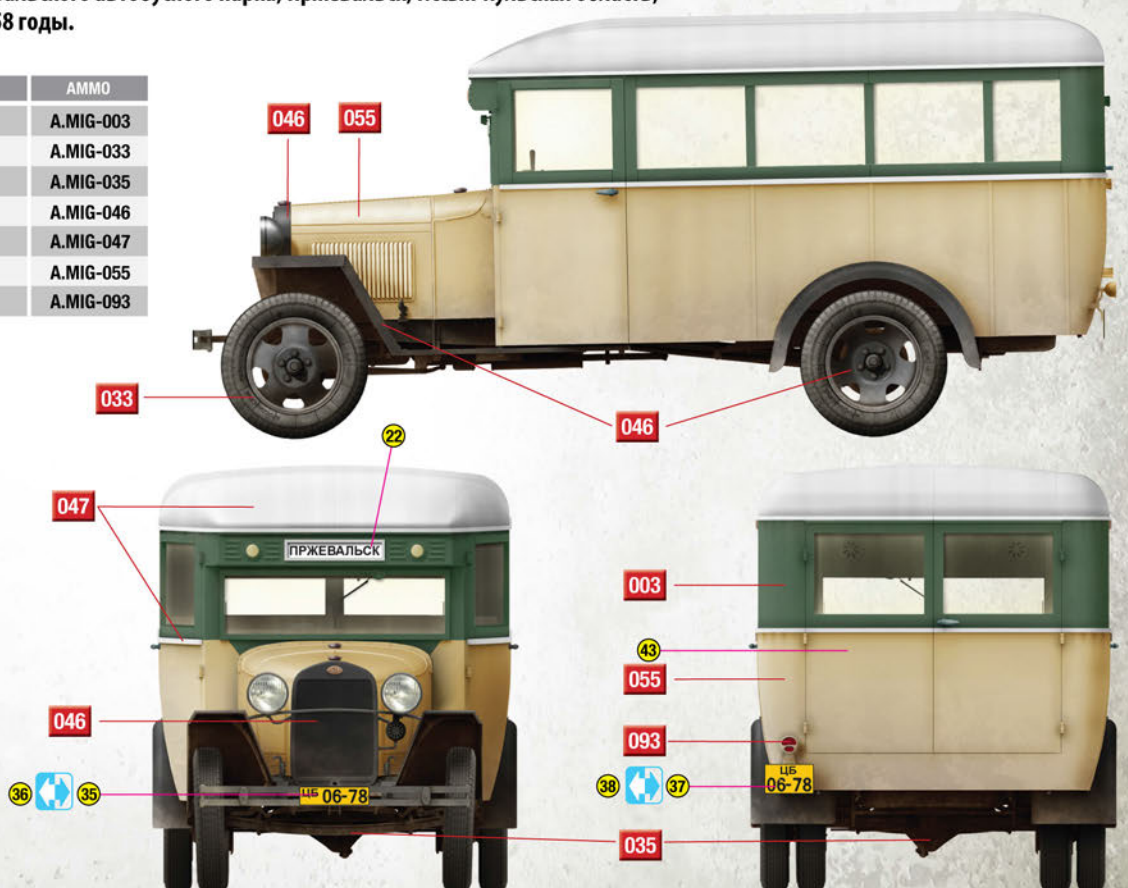

Color info & profiles by



MiniART : 38005

Service bus for unknown organization/enterprise, Gorky city (now Nizhny Novgorod), 1940-ies.  
 Служебный автобус неустановленной организации/предприятия, Горький, 40-е годы.

COLOR NAME	AMMO
Rubber & Tires	A.MIG-033
Dark Tracks	A.MIG-035
Matt Black	A.MIG-046
Yellow	A.MIG-048
Red	A.MIG-049
Crystal Red	A.MIG-093
Steel	A.MIG-191

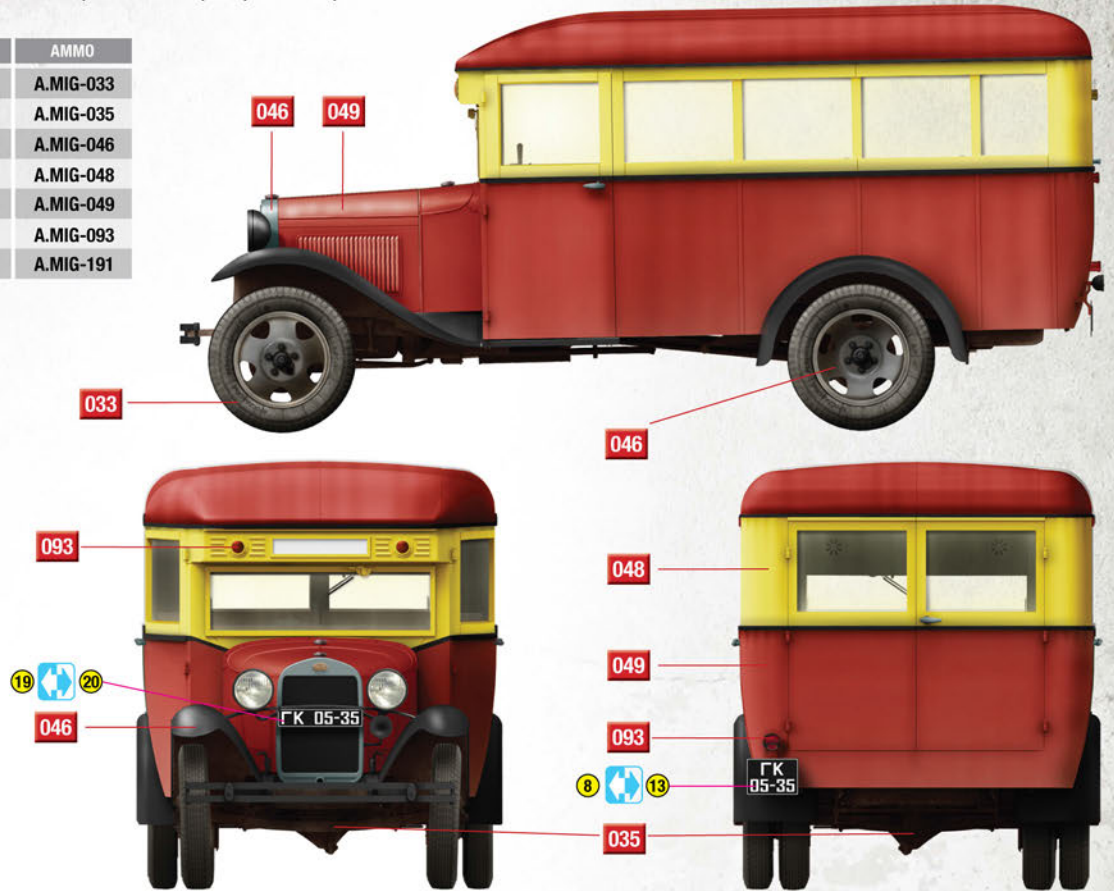

Service bus for "Aeroflot" company, Moscow, 1946.  
 Служебный автобус предприятия «Аэрофлот», Москва, 1946 год.

COLOR NAME	AMMO
Rubber & Tires	A.MIG-033
Dark Tracks	A.MIG-035
Matt Black	A.MIG-046
White	A.MIG-047
French Blue	A.MIG-062
Dull Green	A.MIG-077
Crystal Red	A.MIG-093
Steel	A.MIG-191
Gray Shine	A.MIG-911
Yellow	A.MIG-048



Color info & profiles by



MiniART : 38005

### Service bus for Kharkov rope plant, Kharkov, 1938-41.

Служебный автобус Харьковского Канатного завода, Харьков, 1938-1941 годы.

COLOR NAME	AMMO
Rubber & Tires	A.MIG-033
Dark Tracks	A.MIG-035
Matt Black	A.MIG-046
White	A.MIG-047
Crystal Red	A.MIG-093
Russian Green Base	A.MIG-932

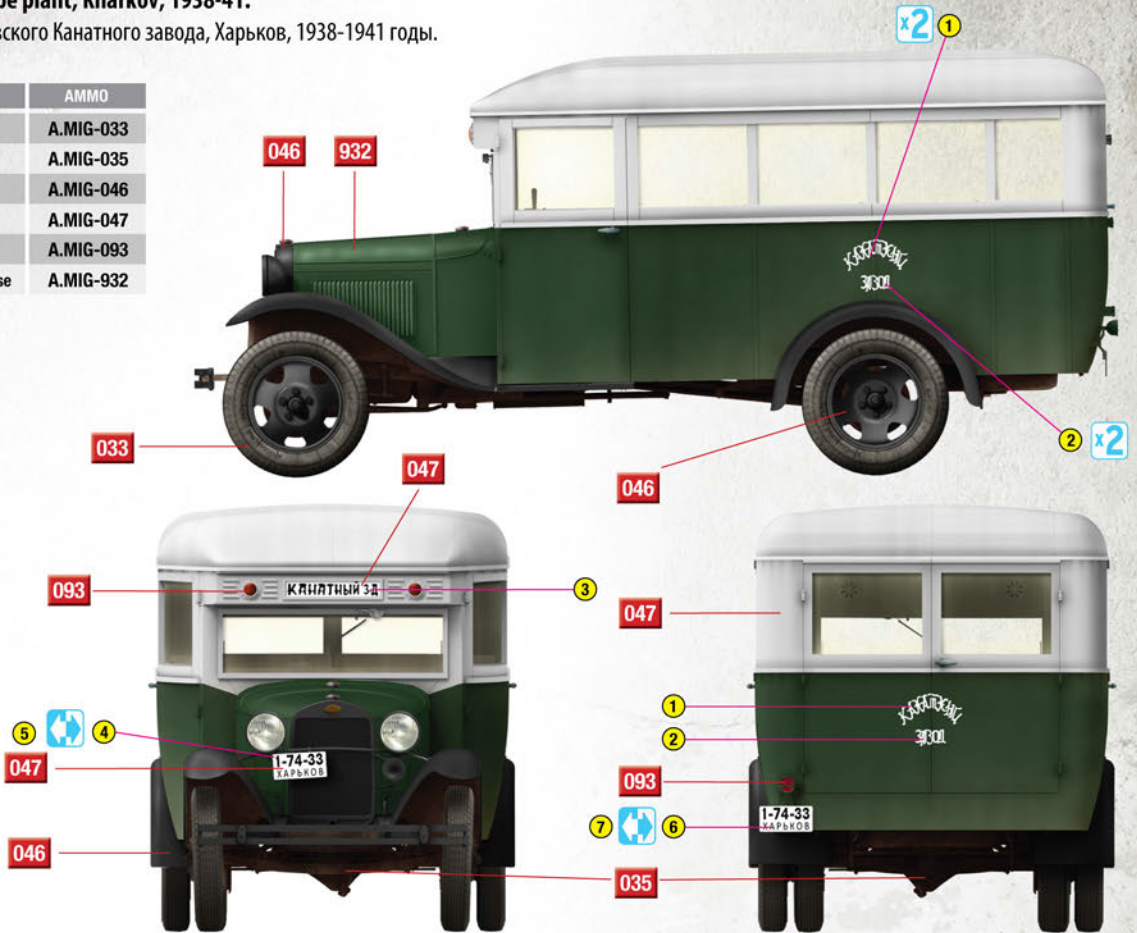

### Service bus for All-Union Young Pioneer camp "Artek". Gurzuf settlement, Crimean Peninsula, 1940-41.

Служебный автобус детского пионерского лагеря «Артек», поселок Гурзуф, Крым, 1940-1941 годы.

COLOR NAME	AMMO
Rubber & Tires	A.MIG-033
Dark Tracks	A.MIG-035
Matt Black	A.MIG-046
Yellow	A.MIG-048
Crystal Red	A.MIG-093
Medium Blue	A.MIG-103
Gray Shine	A.MIG-911

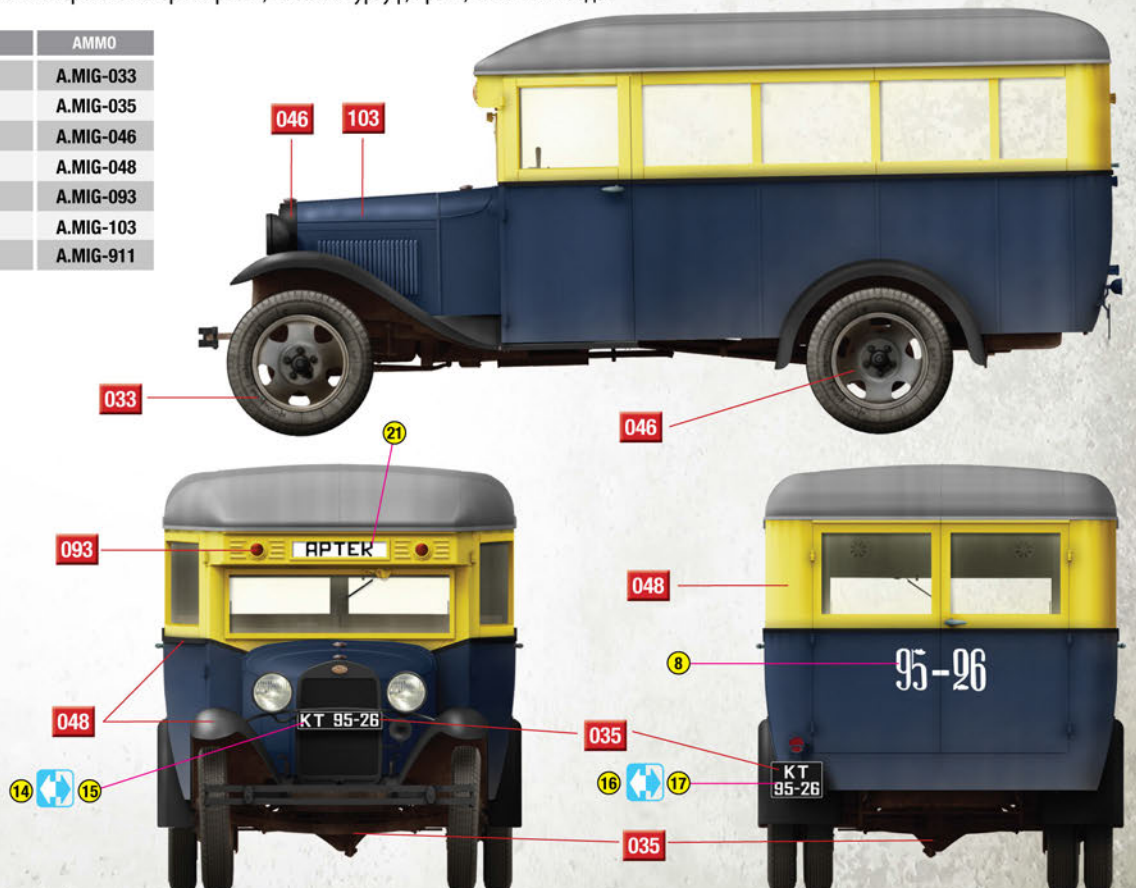

Color info & profiles by

