

**ROBERT McDERMOTT'S P-38 LIGHTNING**  
 "Fatty Patty Ann" of the 474th Fighter Group

**UNDERSIDE**

Decal Art by Scott Hall



FS 35102 Blue

FS 35102 Blue

Star upper right wing same position as lower wing star

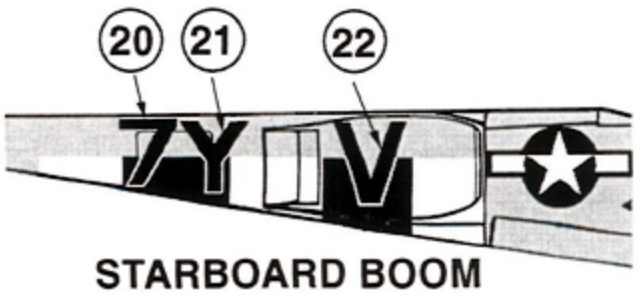
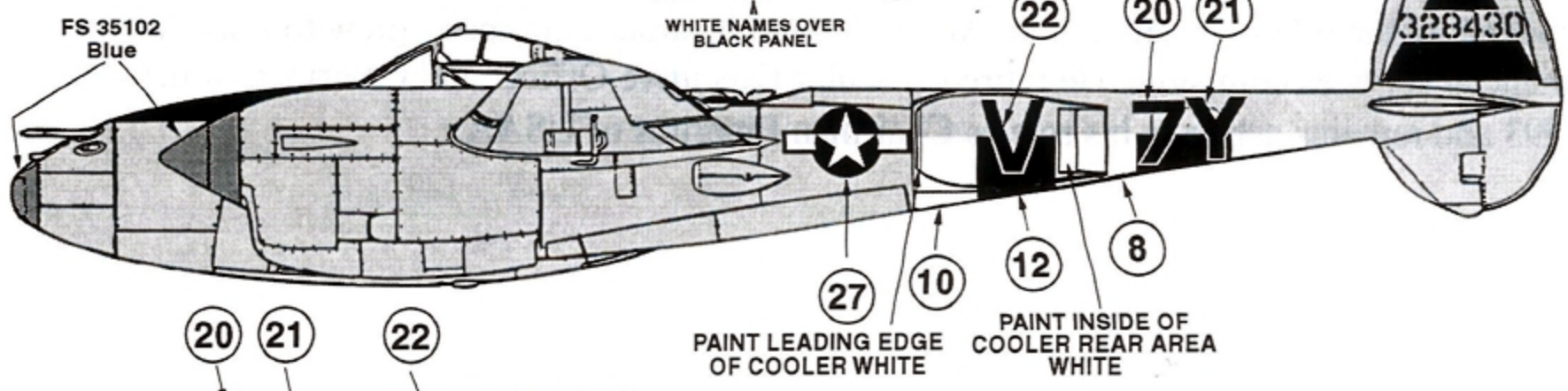
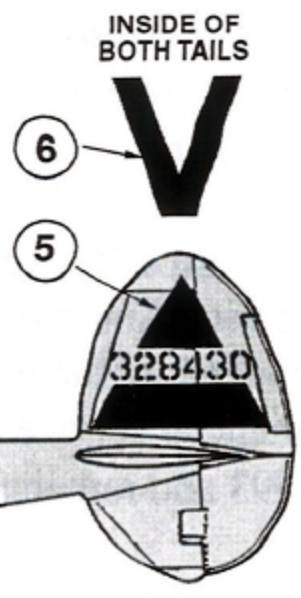
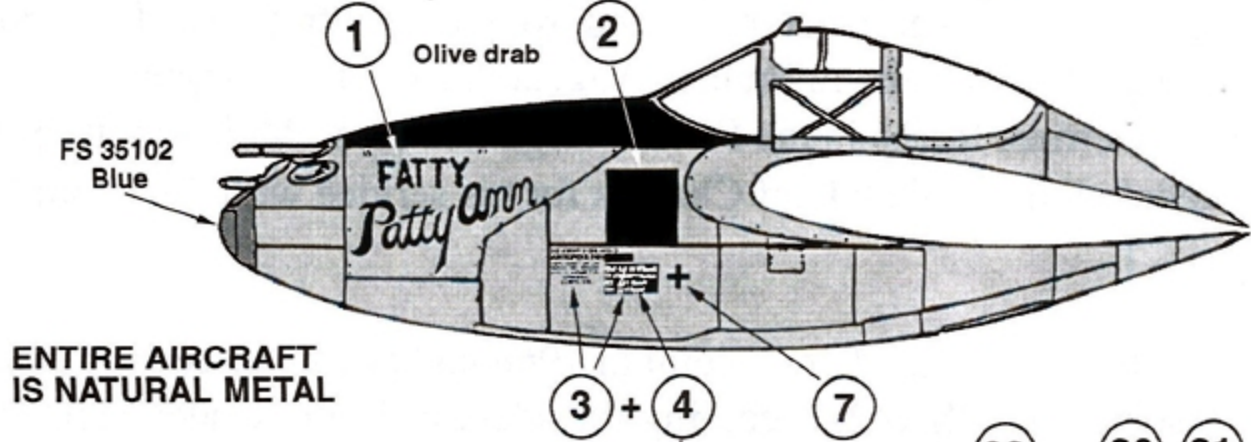
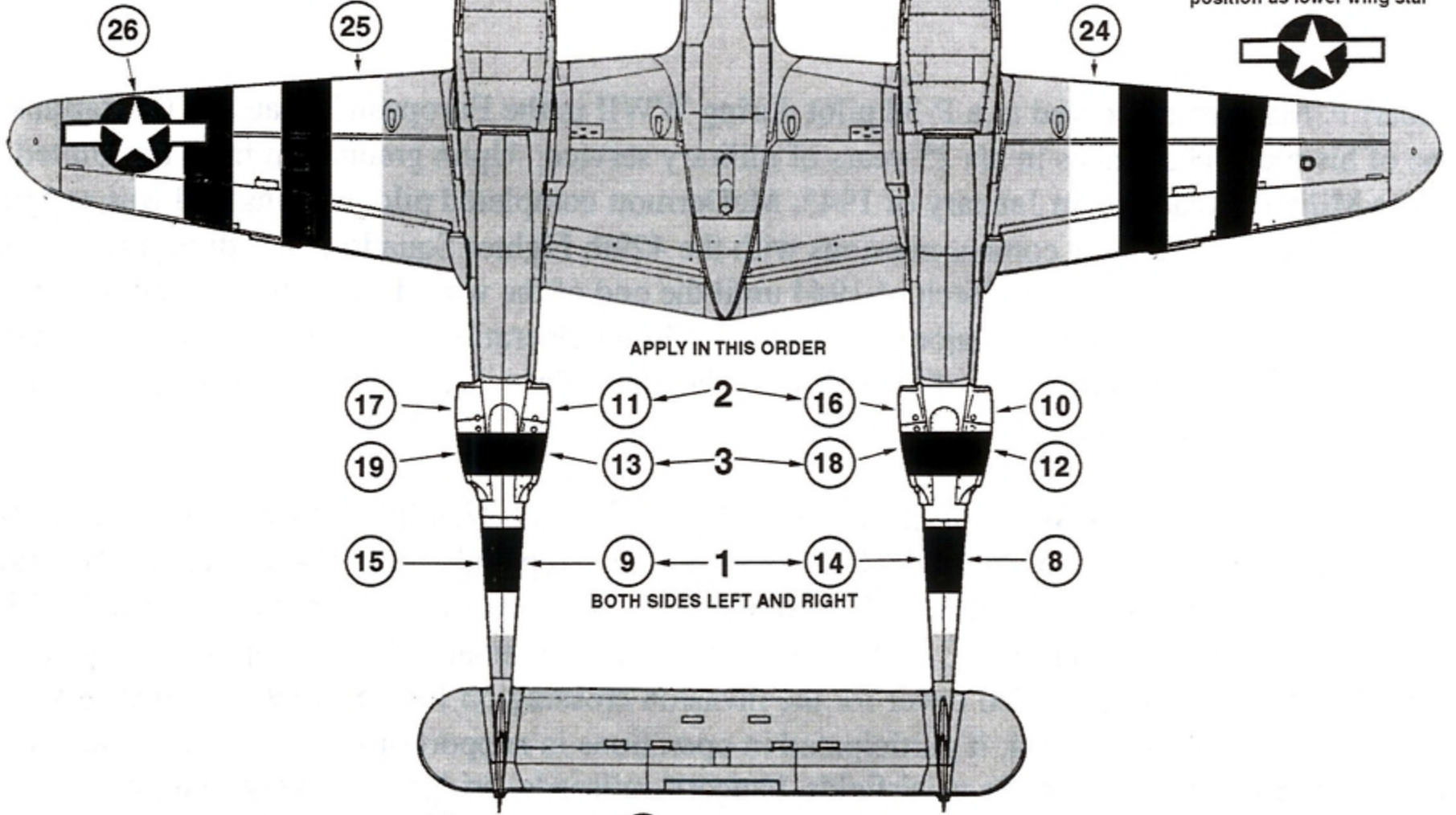

# Robert F. McDermott

Robert F. McDermott served as a P-38 pilot during WWII in the European Theater of Operations -- one of his many challenges in his 25 years of military service. Upon graduation from the United States Military Academy in January of 1943, McDermott completed pilot training and was assigned to fly combat. He flew 61 combat missions with the 429th Fighter Squadron, 474th Fighter Group, and the Ninth Air Force from March of 1944 until the end of the war. During this period he was promoted to Captain and then Major serving as the Group Operations Officer. His aircraft, "Fatty Patty Ann," was named in honor of his first born daughter, Patricia Ann, and is the subject of this commemorative decal sheet.

The group landed at RAF Warmwell, England, March 12, 1944; Neuilly, France, August 12, 1944; St. Marceau, France, September 2, 1944; Peronne, France, September 9, 1944; Florennes, Belgium, October 1, 1944; Strassfeld, Germany, March 31, 1945; and Langensalza, Germany, April 22, 1945 until the end of the war in Europe. The Group flew it's first combat fighter sweep over France on April 25, 1944. It also provided cover for the invasion crossing on June 5-6, 1944. After moving to the Continent in August, 1944, it participated in operations in support of ground forces. The Group bombed and strafed such targets as airfields, hangers, railroads, bridges, highways, barges, ammunition depots, fuel dumps, gun emplacements and troop concentrations. The Group received a Distinguished Unit Citation for a mission in France, August 23, 1944, in support of a joint air-ground against retreating German forces in the Falaise-Argentan area. McDermott received the Bronze Star and Air Medal with five Oak Leaf Clusters for his service with the 474th Fighter Group in WWII.

He retired from the Air Force as a Brigadier General in 1968 and began his second career at United Service Automobile Association (USAA), becoming President in 1969. Under McDermott's leadership, the relatively small, San Antonio based insurance company grew to a world class financial services company. He retired as Chief Executive Officer and Chairman of the Board in 1993 and remains active in his role as Chairman Emeritus of USAA.