



HIGH QUALITY SCALE MODEL, RESIN MODEL
Fiat CR.42

Designed as the successor to the Fiat CR.32, the Fiat CR.42 Falco was larger than its predecessor and fitted with a Fiat A-74 radial engine. The CR.42 made its maiden flight on 23rd May 1938 and at the outbreak of Second World War it equipped seven combat units from Italy to Somaliland. The CR.42 fought in France, the Mediterranean area, Balkans, North and East Africa. It was even dispatched to Belgium to take part in the Battle of Britain.

Although it had an open canopy, lacked improved armament and had the limits of its radial air-cooled engine, the fighter was viewed favorably by both pilots and ground crew for its reliability and easy maintenance. During 1942 it was regulated to second line units after being equipped with underwing bomb rack for ground attack duties and also in night fighter intercept flights with scarce results. Production for Regia Aeronautica ended in 1944. The CR.42 served with many countries, with examples exported to Sweden, Hungary and Belgium. The Luftwaffe requisitioned less than a hundred CR.42's, using them in night fighters missions. At the end of the war, several were converted into two-seat trainers and remained in service with the new Italian Air Force some more years, until its complete withdrawal.

Only one example survived the war, and it is now preserved in the Swedish Air Force Museum in Linköping. Some years ago, AREA of Venegono (Varese, Northern Italy), put together many original parts coming from Italy and Sweden, to build two new examples. The first is now on display at Vigna di Valle Italian Air Force Museum, resplendent in its wartime 162 Squadriglia's colors, while the second example, resides at Duxford (UK) where it will soon make its maiden flight.

TECHNICAL DATA

Crew:	1
Length:	8,25 m
Wingspan - top wing:	9,7 m
Wingspan - bottom wing:	6,5 m
Height:	3,58 m
Wing area:	22,4 m ²
Empty weight:	1,78 kg
Loaded weight:	2,29 kg
Powerplant:	1x Fiat A.74 Rc38
	14-cylinders radial engine (840 hp)
Maximum speed:	441 km/h
Range:	780 km
Service ceiling:	10,210 m.
Armament:	2 x 12,7 mm Breda SAFAT + 200 kg bombs

Italian version

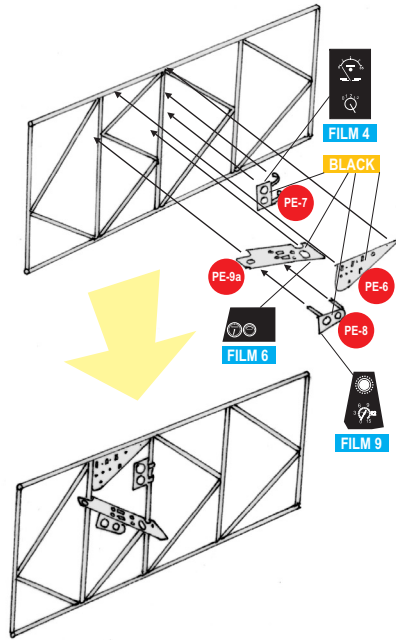
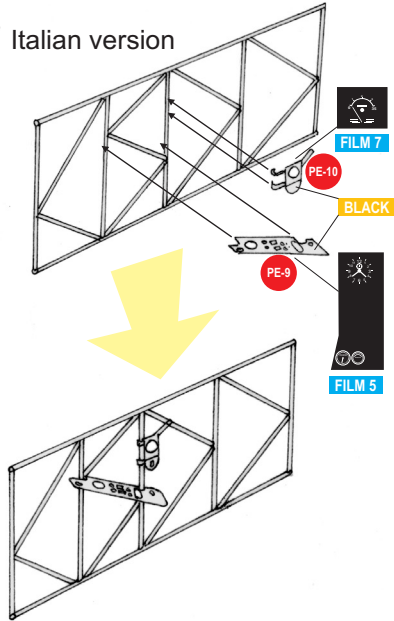

Swedish and German version

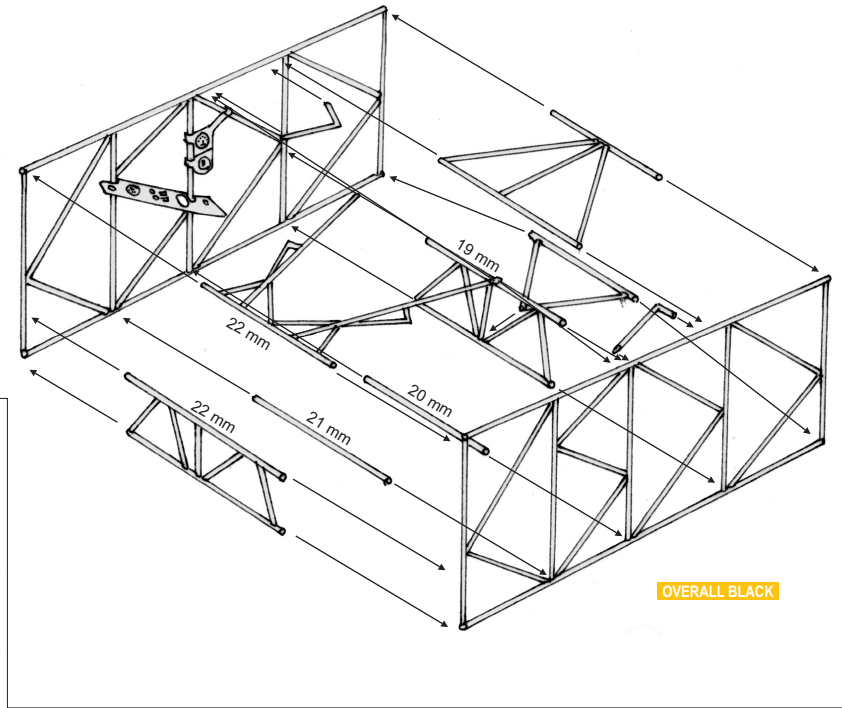

LIGHT GREY

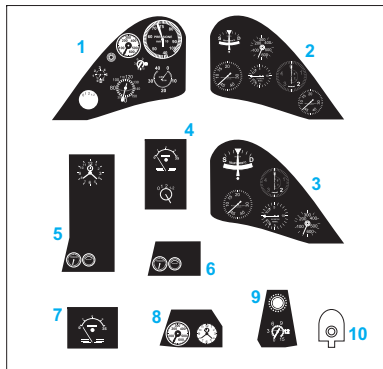
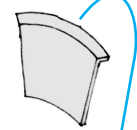

Film set

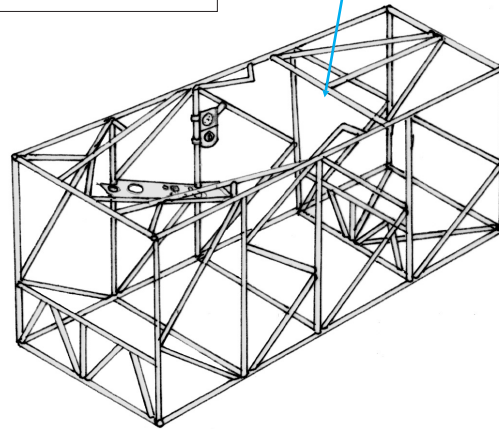

PE9 & PE9a colours

Adjust PE shape

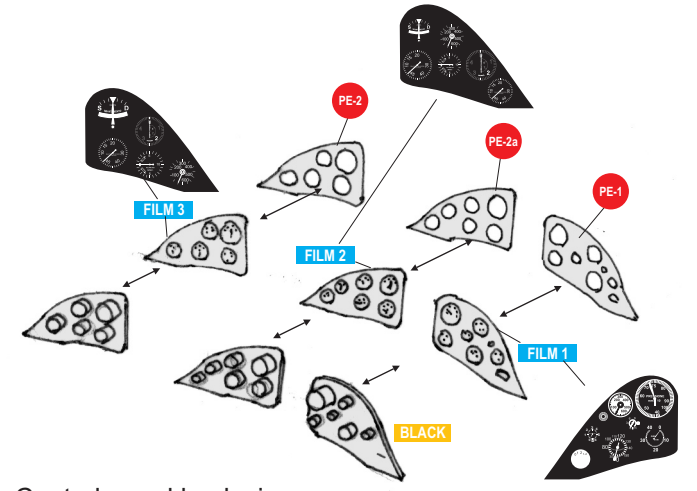
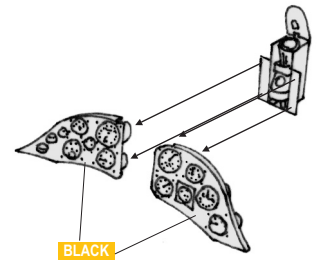
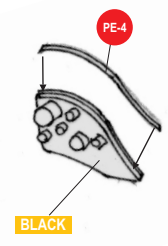
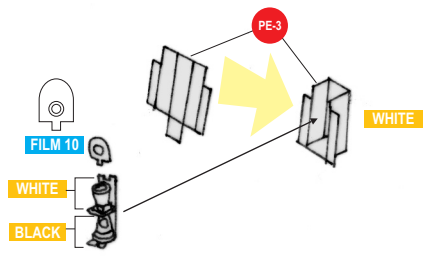

Control panel back view

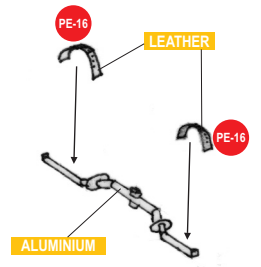
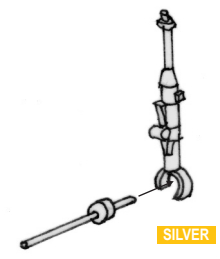
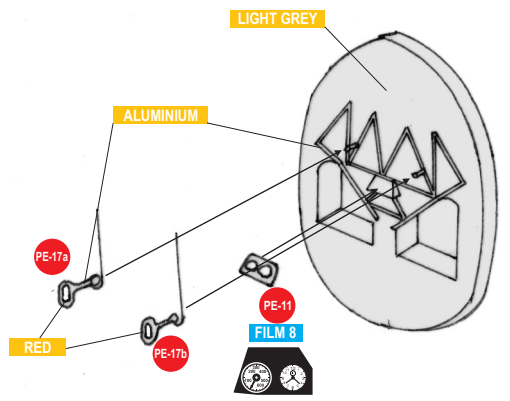

Italian version

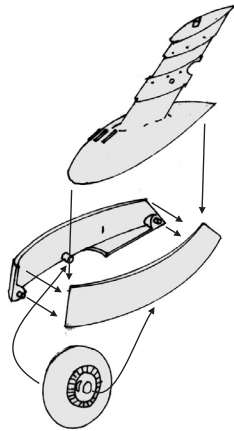

Swedish version

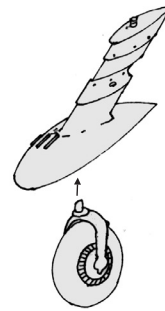
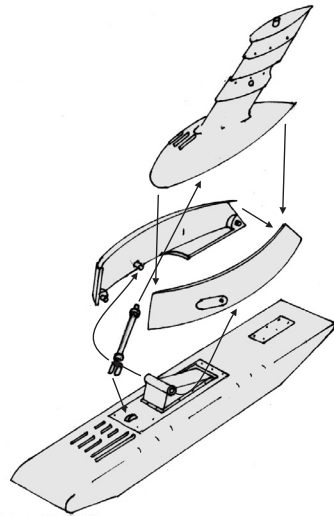

German version

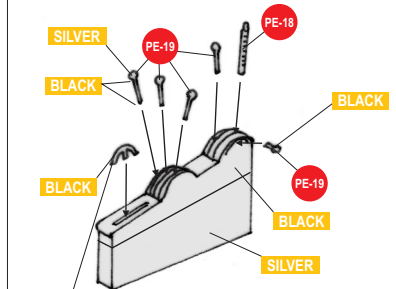
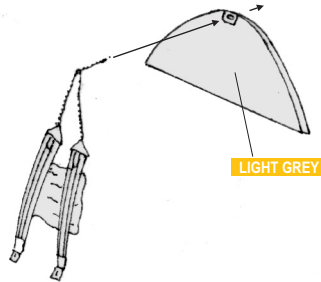
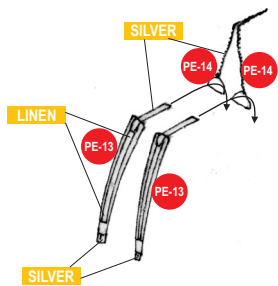
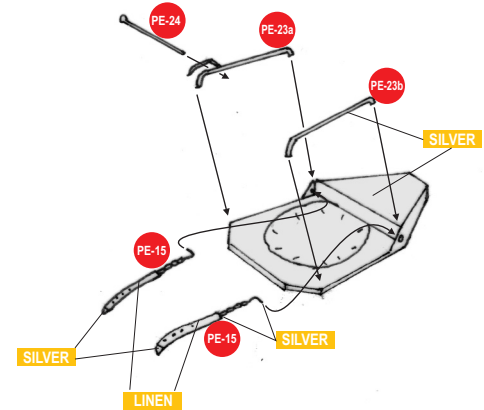

prepare on your own

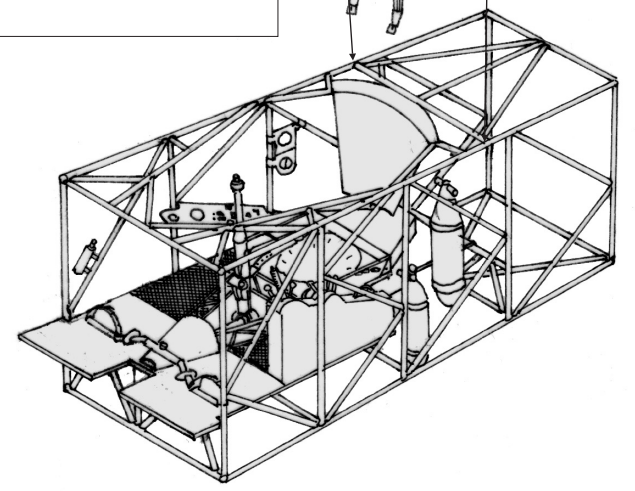
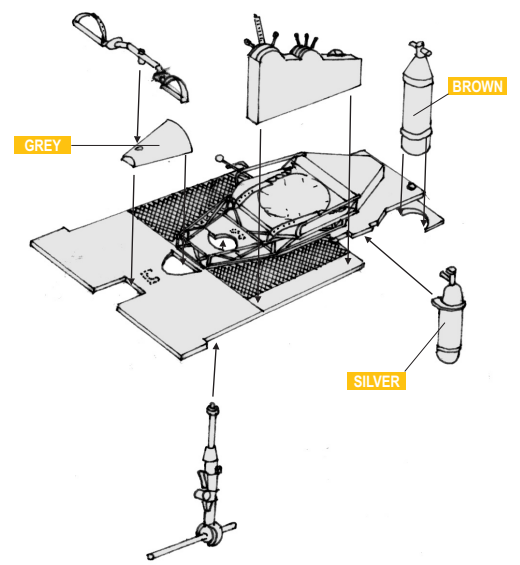
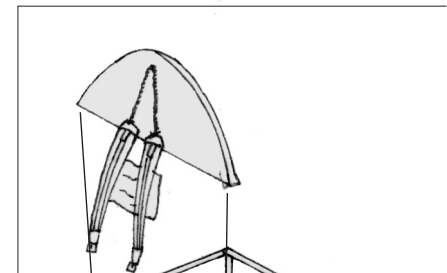
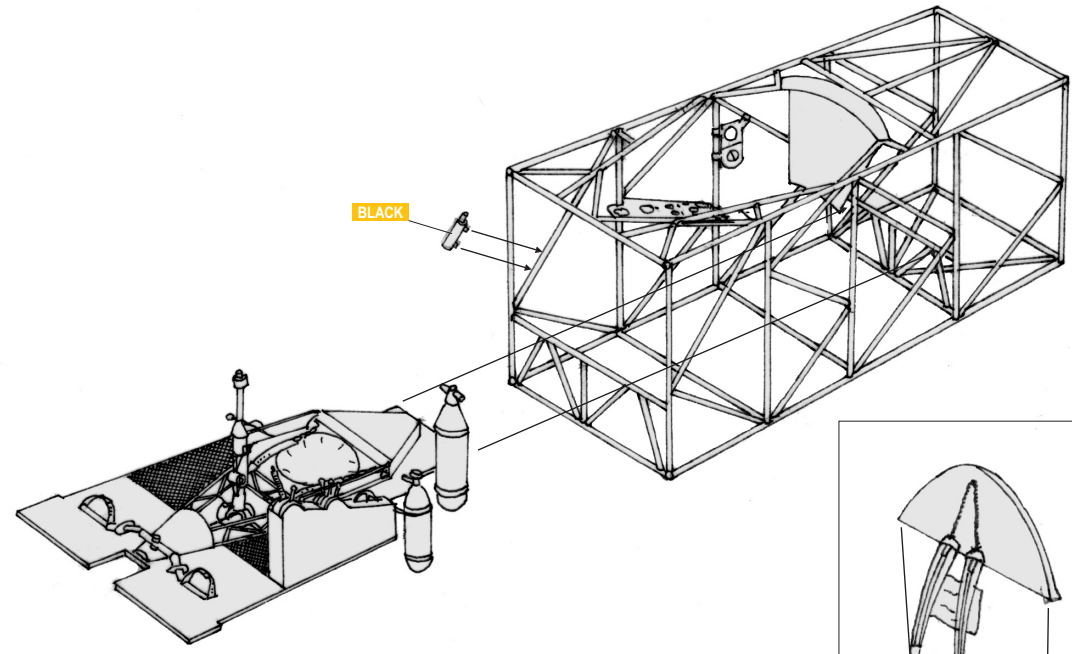
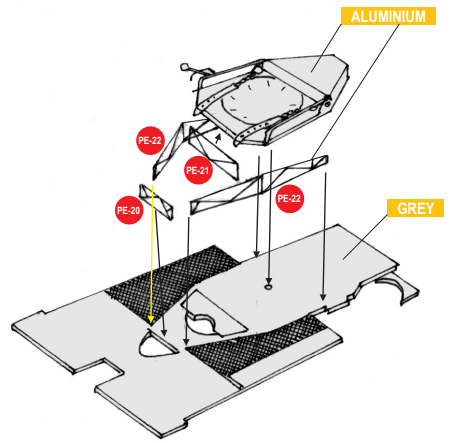

Spark plugs wires
– prepare on your own

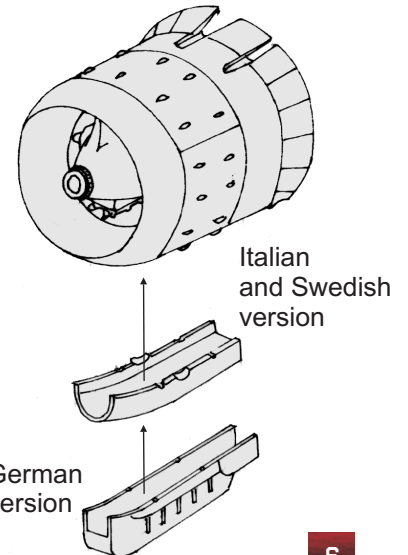
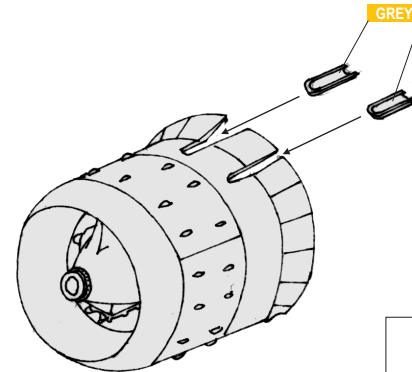
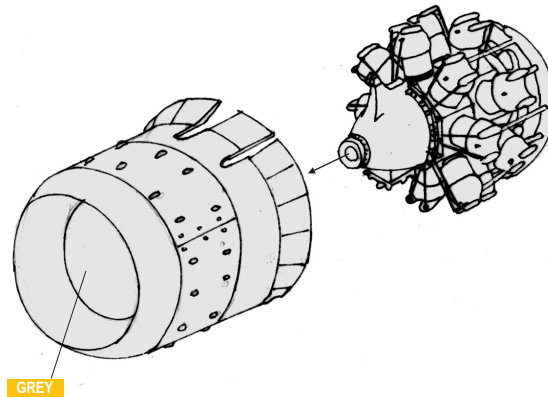
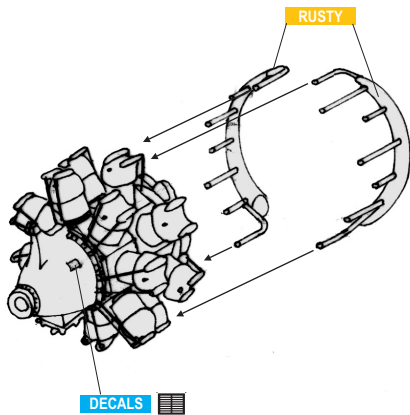
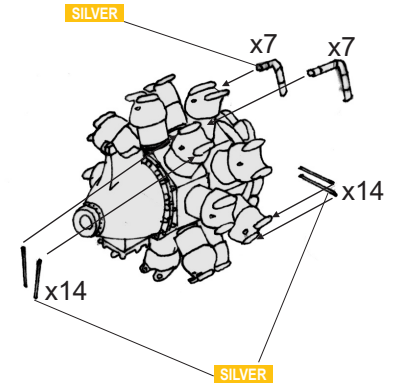
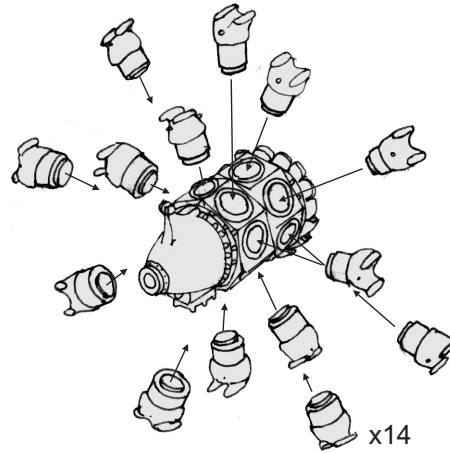
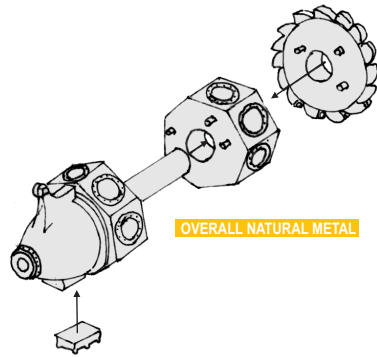
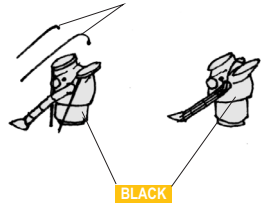

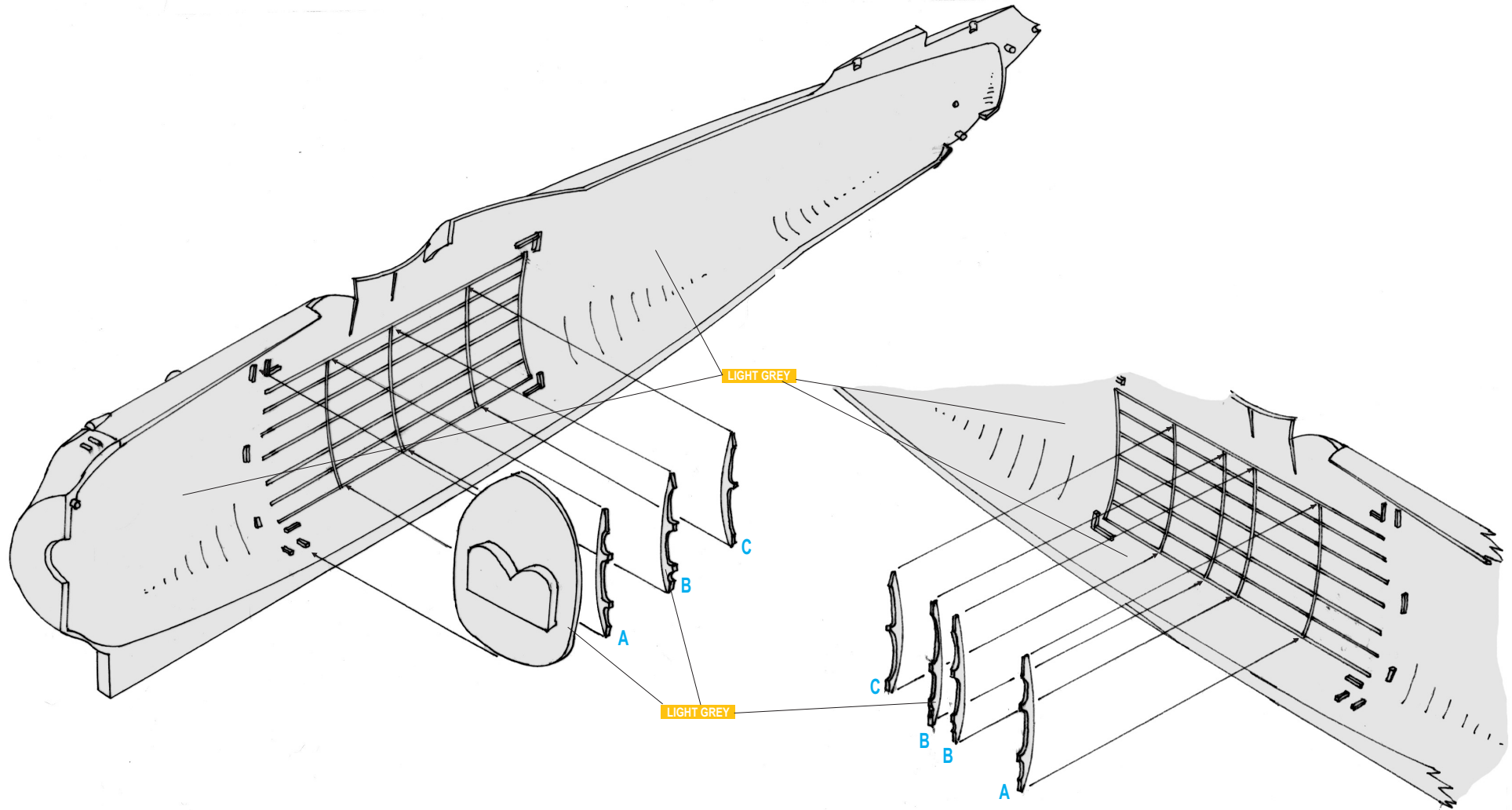

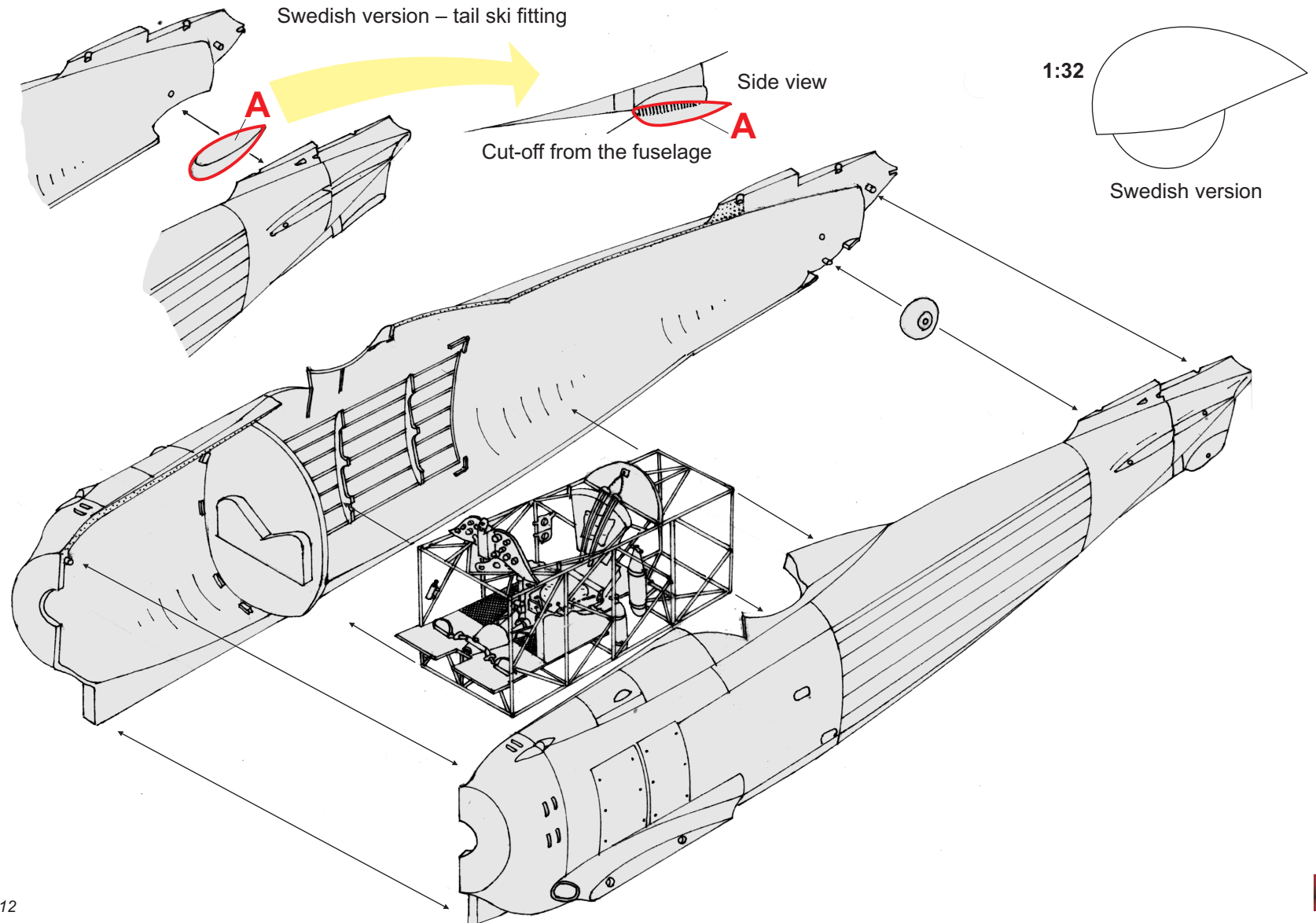

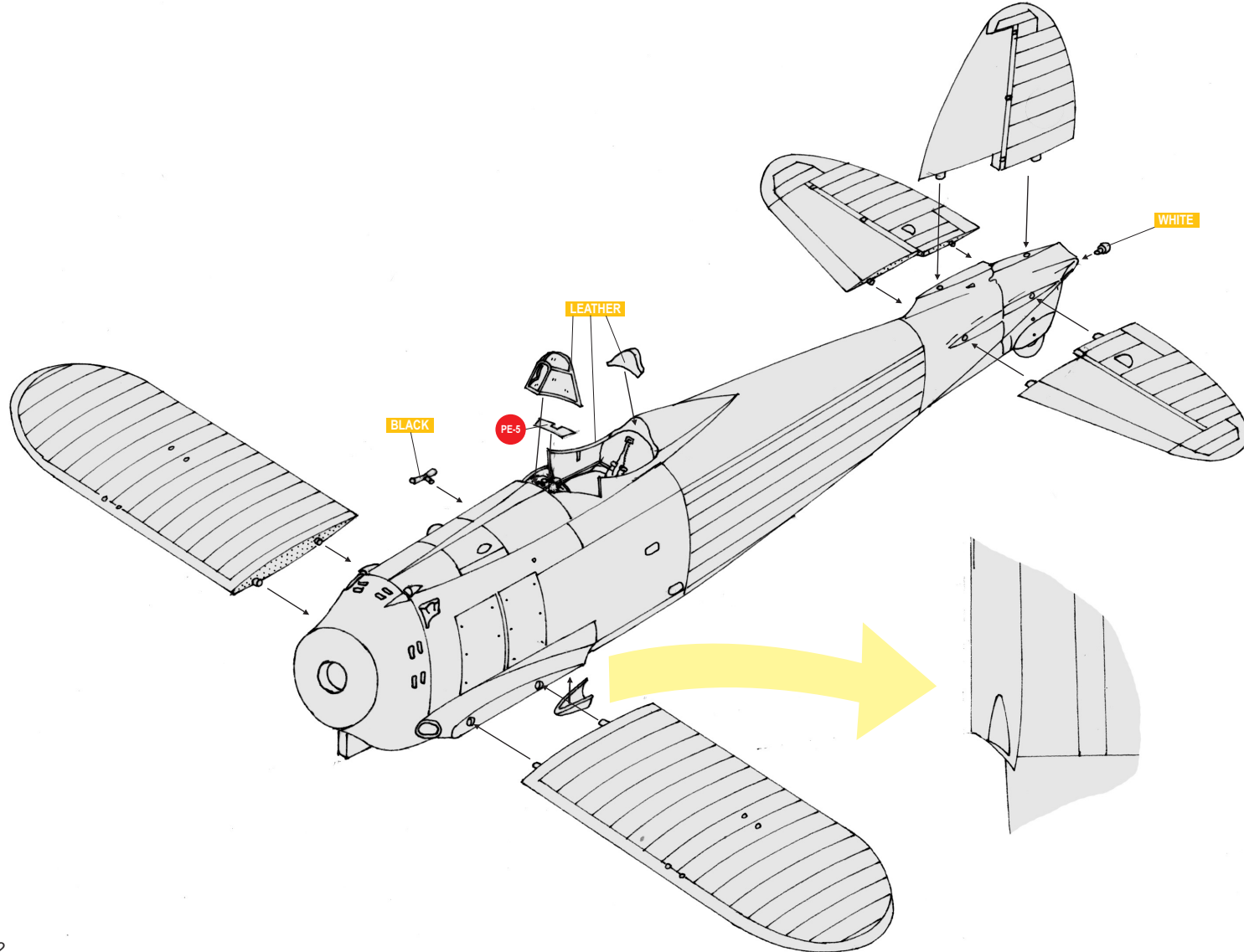

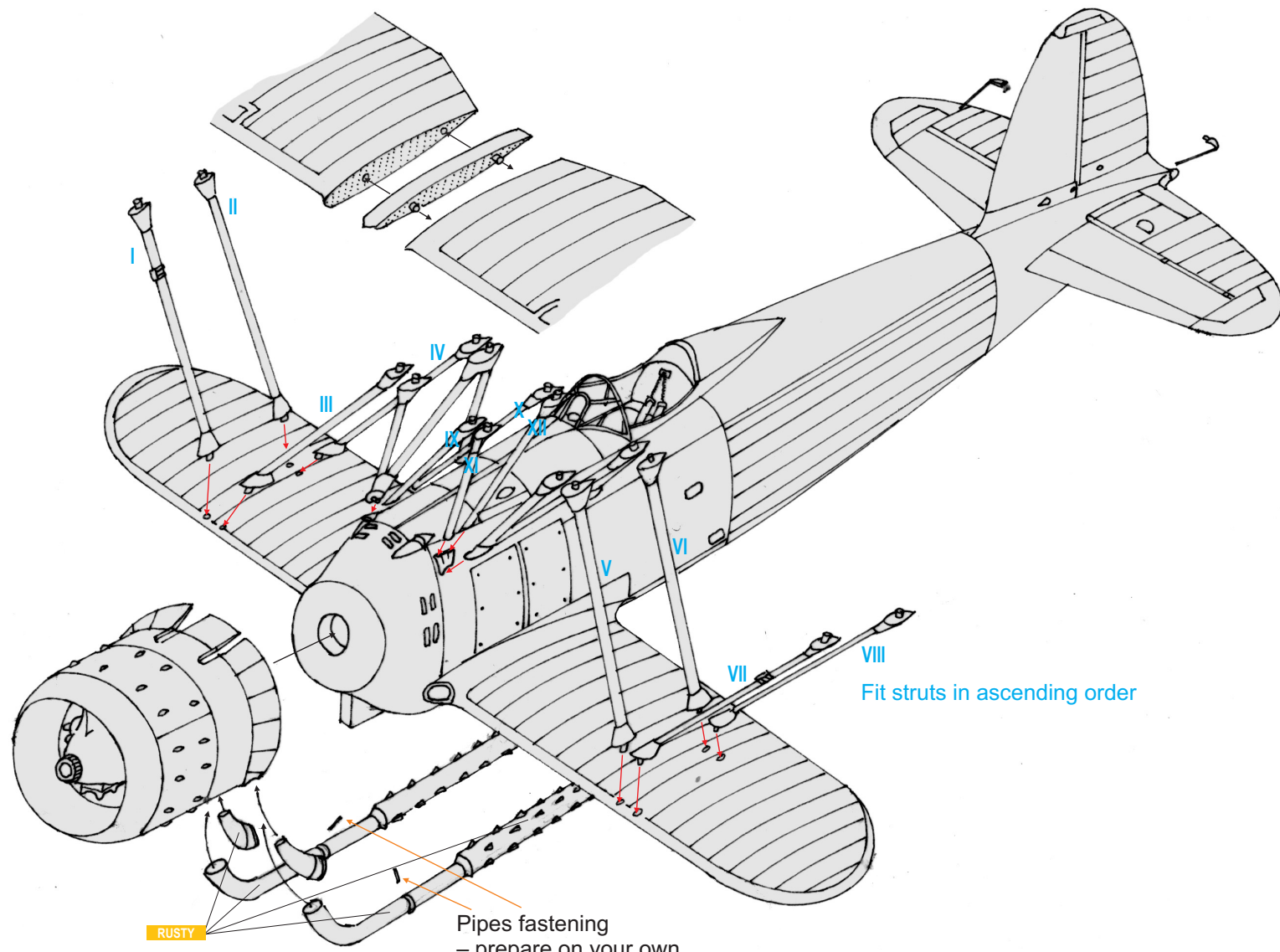

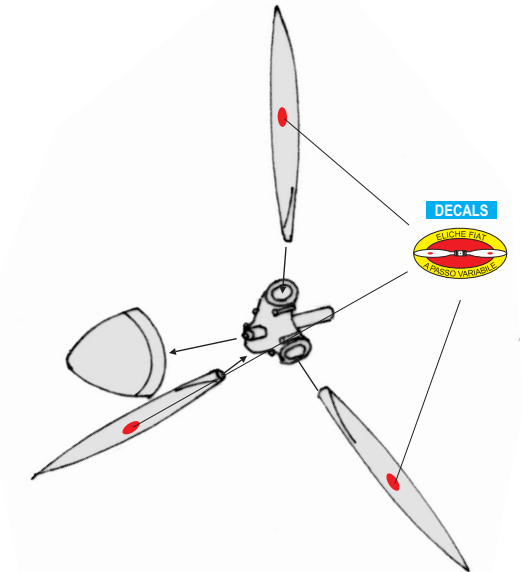
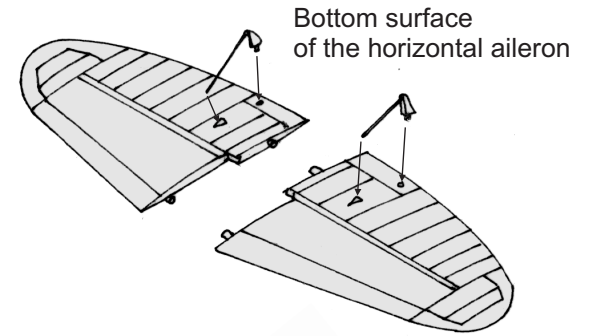
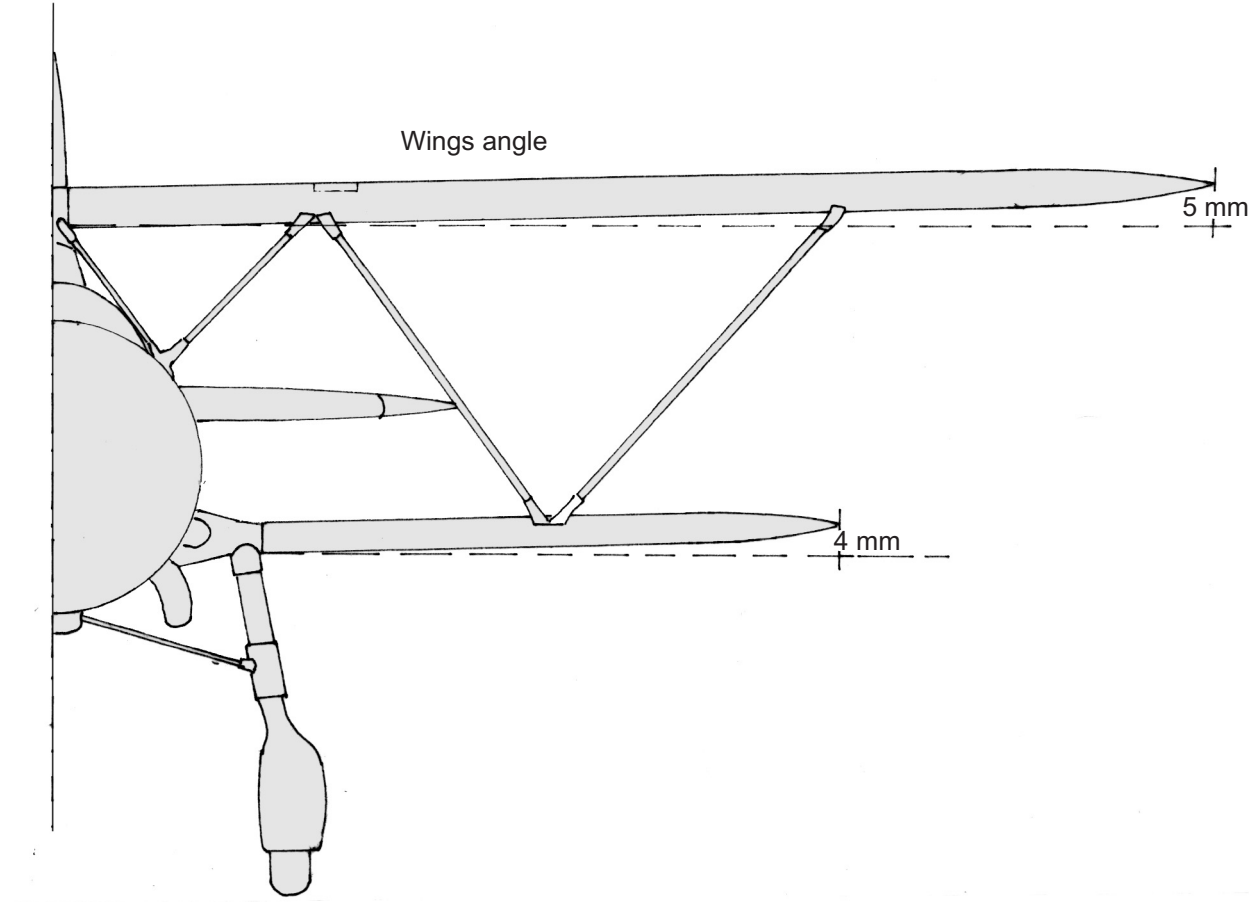

Prepare on your own

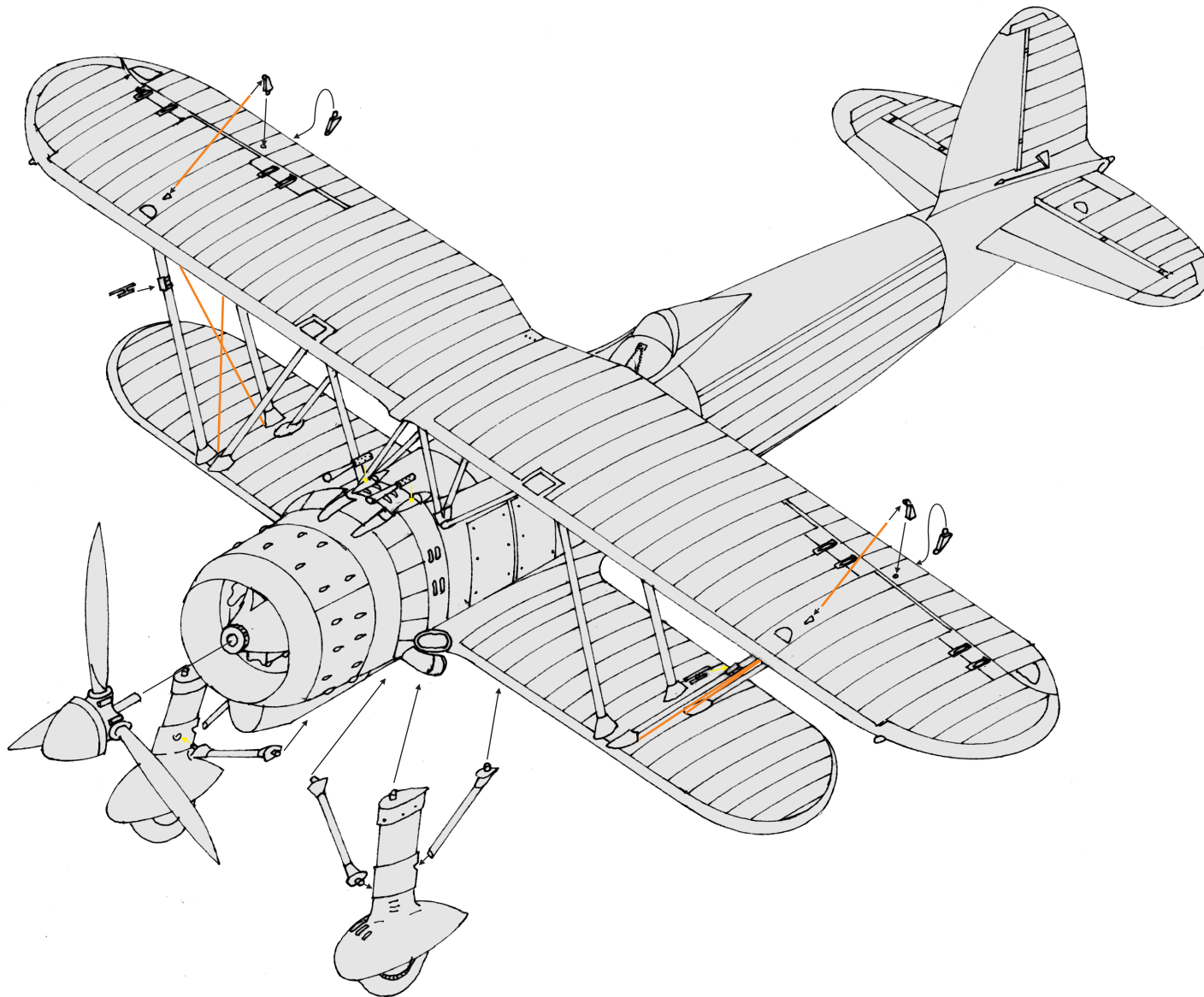

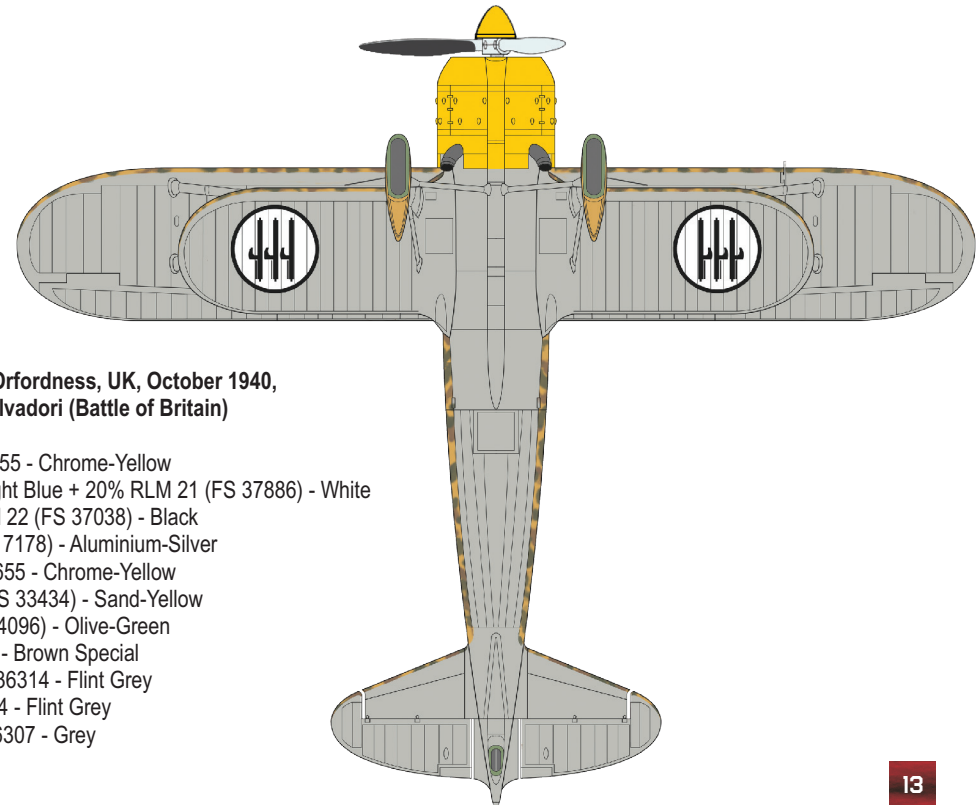
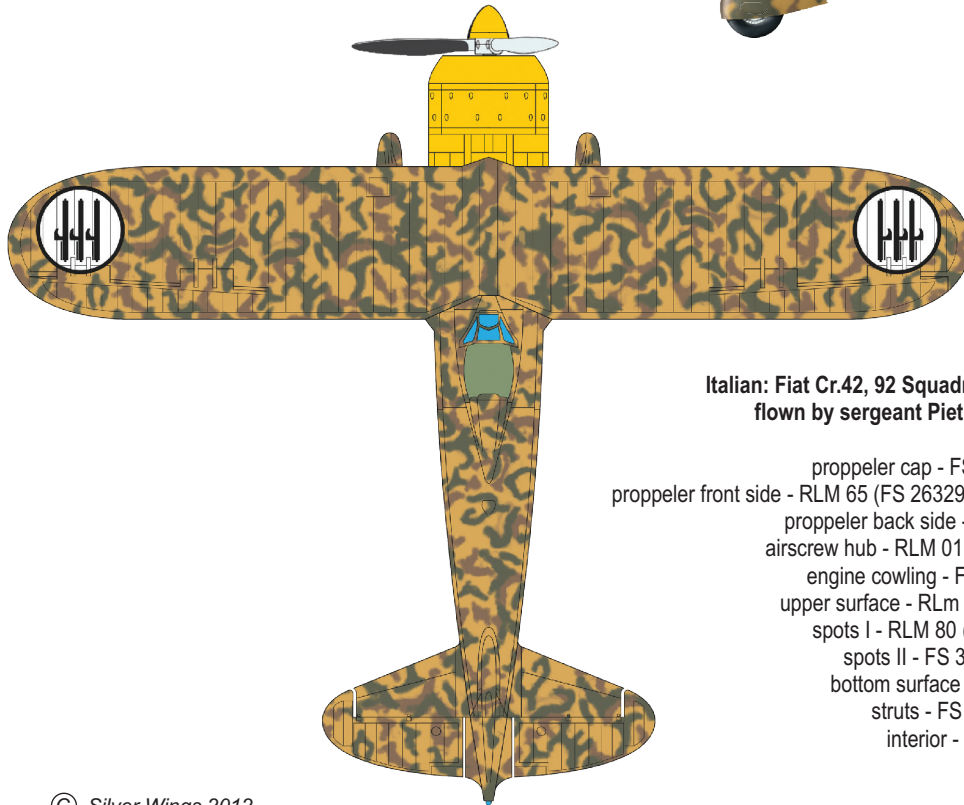

**Italian: Fiat Cr.42, 92 Squadron, Orfordness, UK, October 1940,
flown by sergeant Pietro Salvadori (Battle of Britain)**

propeller cap - FS 33655 - Chrome-Yellow
 propeller front side - RLM 65 (FS 26329) - Light Blue + 20% RLM 21 (FS 37886) - White
 propeller back side - RLM 22 (FS 37038) - Black
 airscrew hub - RLM 01 (FS 17178) - Aluminium-Silver
 engine cowling - FS 33655 - Chrome-Yellow
 upper surface - RLM 79 (FS 33434) - Sand-Yellow
 spots I - RLM 80 (FS 34096) - Olive-Green
 spots II - FS 30140 - Brown Special
 bottom surface - FS 36314 - Flint Grey
 struts - FS 36314 - Flint Grey
 interior - FS 36307 - Grey

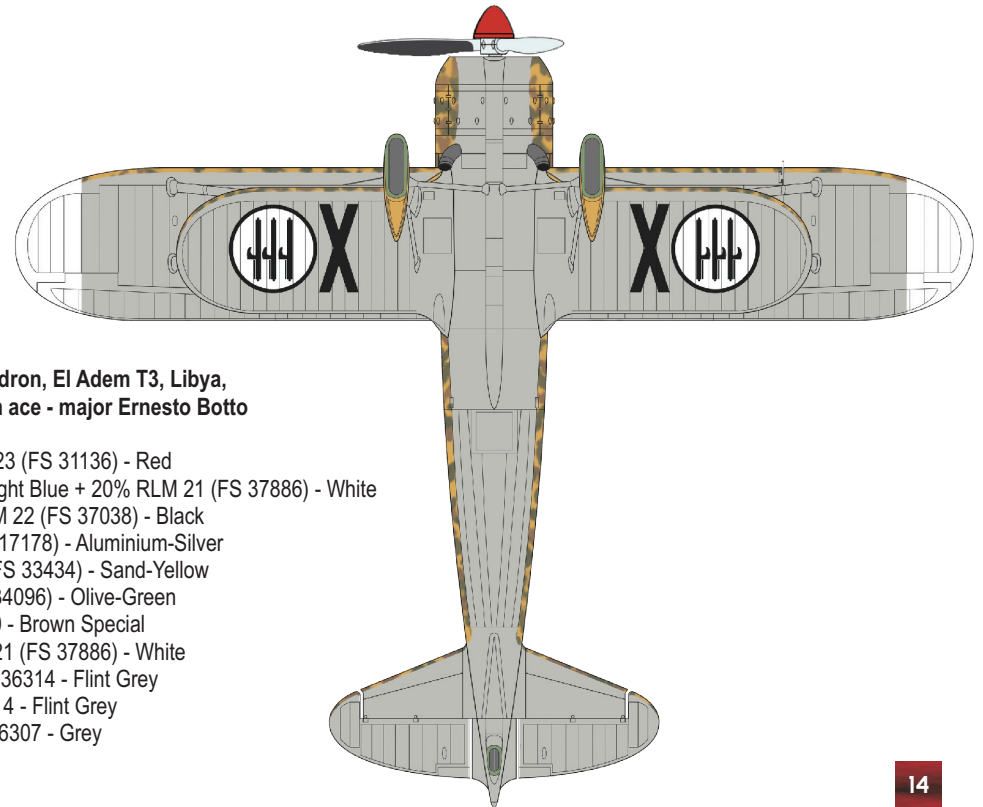
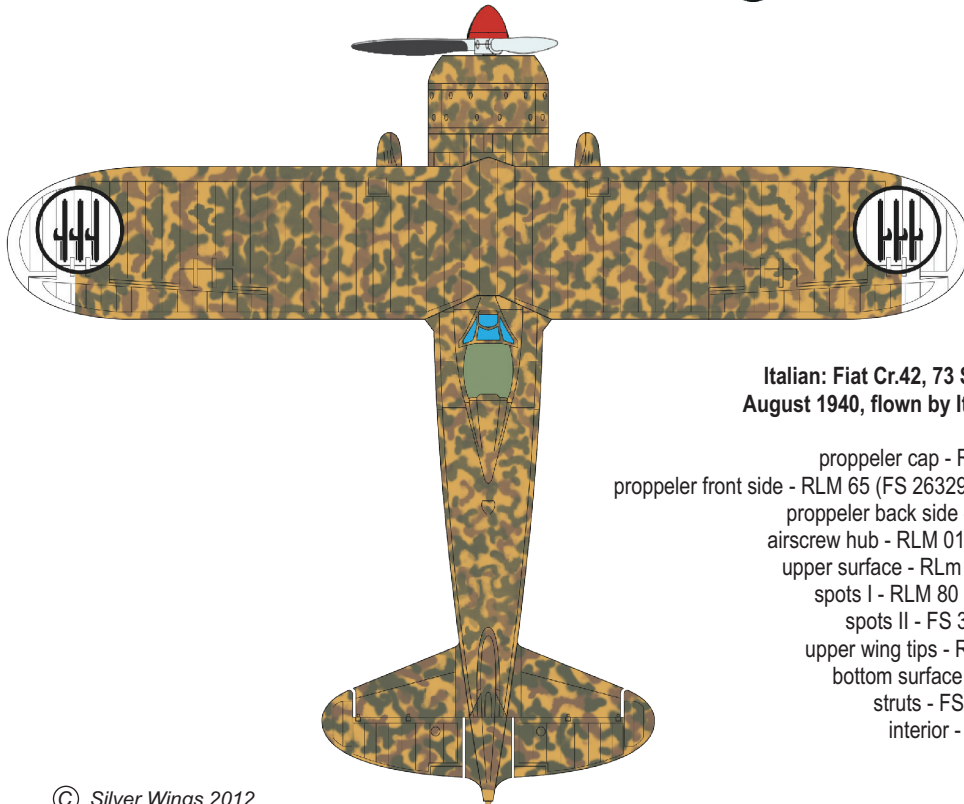

Italian: Fiat Cr.42, 73 Squadron, El Adem T3, Libya, August 1940, flown by Italian ace - major Ernesto Botto

- propeller cap - RLM 23 (FS 31136) - Red
- propeller front side - RLM 65 (FS 26329) - Light Blue + 20% RLM 21 (FS 37886) - White
- propeller back side - RLM 22 (FS 37038) - Black
- airscrew hub - RLM 01 (FS 17178) - Aluminium-Silver
- upper surface - RLM 79 (FS 33434) - Sand-Yellow
- spots I - RLM 80 (FS 34096) - Olive-Green
- spots II - FS 30140 - Brown Special
- upper wing tips - RLM 21 (FS 37886) - White
- bottom surface - FS 36314 - Flint Grey
- struts - FS 36314 - Flint Grey
- interior - FS 36307 - Grey

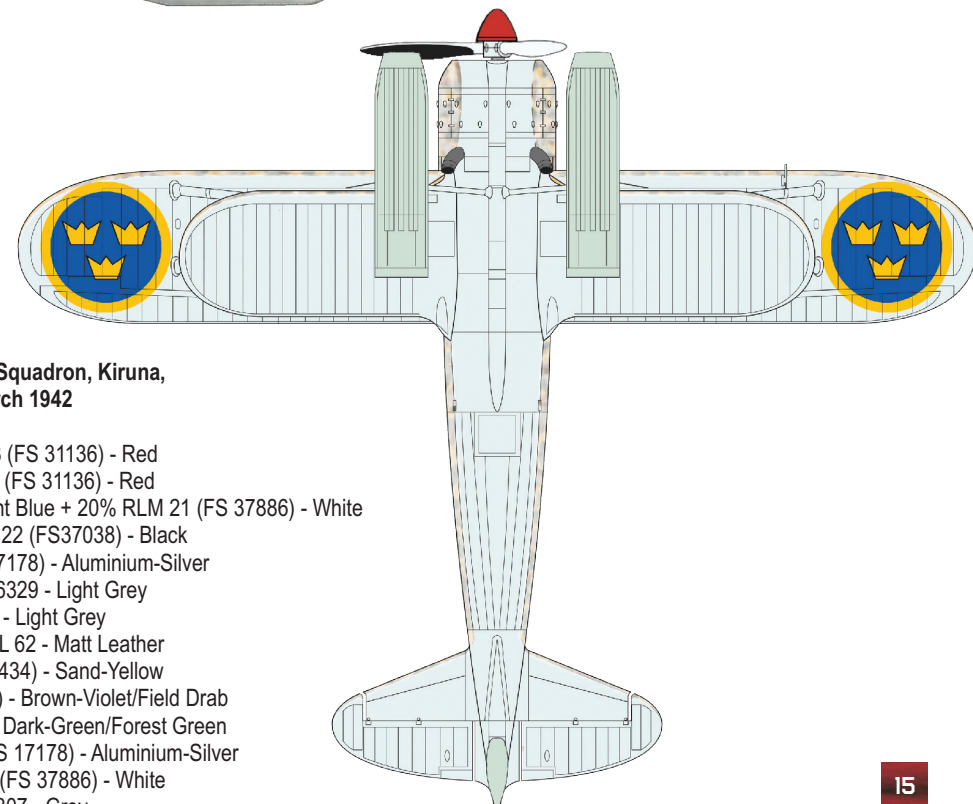
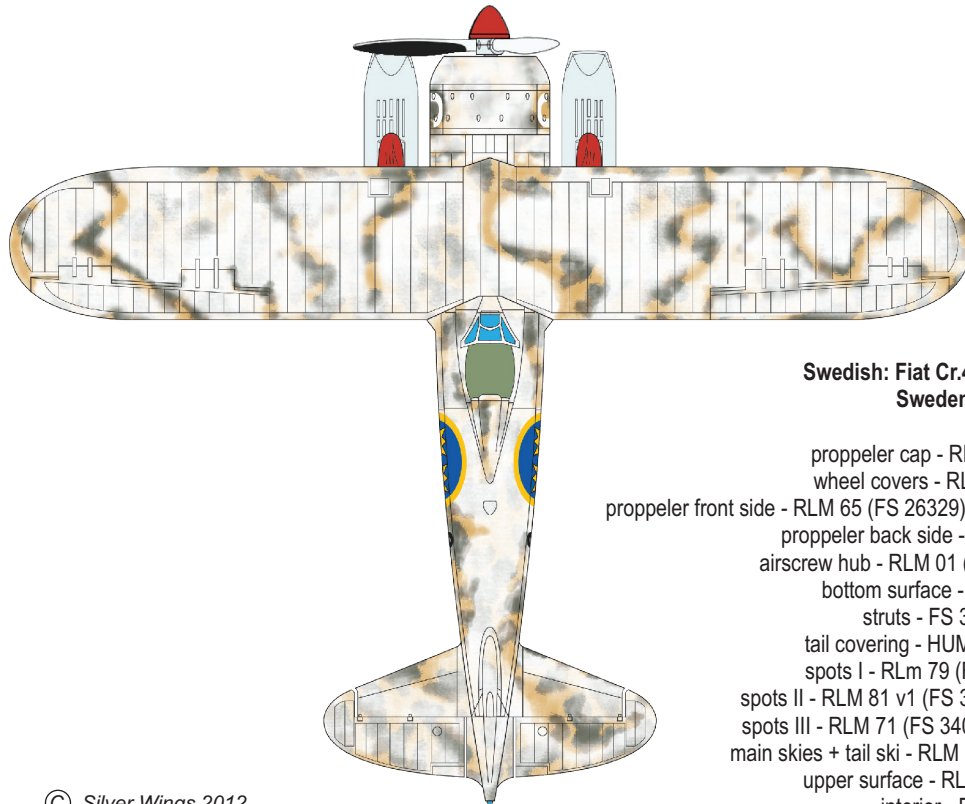

**Swedish: Fiat Cr.42, 1 Squadron, Kiruna,
Sweden, March 1942**

- propeller cap - RLM 23 (FS 31136) - Red
- wheel covers - RLM 23 (FS 31136) - Red
- propeller front side - RLM 65 (FS 26329) - Light Blue + 20% RLM 21 (FS 37886) - White
- propeller back side - RLM 22 (FS37038) - Black
- airscrew hub - RLM 01 (FS 17178) - Aluminium-Silver
- bottom surface - FS 36329 - Light Grey
- struts - FS 36329 - Light Grey
- tail covering - HUMBROL 62 - Matt Leather
- spots I - RLM 79 (FS 33434) - Sand-Yellow
- spots II - RLM 81 v1 (FS 30118) - Brown-Violet/Field Drab
- spots III - RLM 71 (FS 34079) - Dark-Green/Forest Green
- main skies + tail ski - RLM 01 (FS 17178) - Aluminium-Silver
- upper surface - RLM 21 (FS 37886) - White
- interior - FS 36307 - Grey

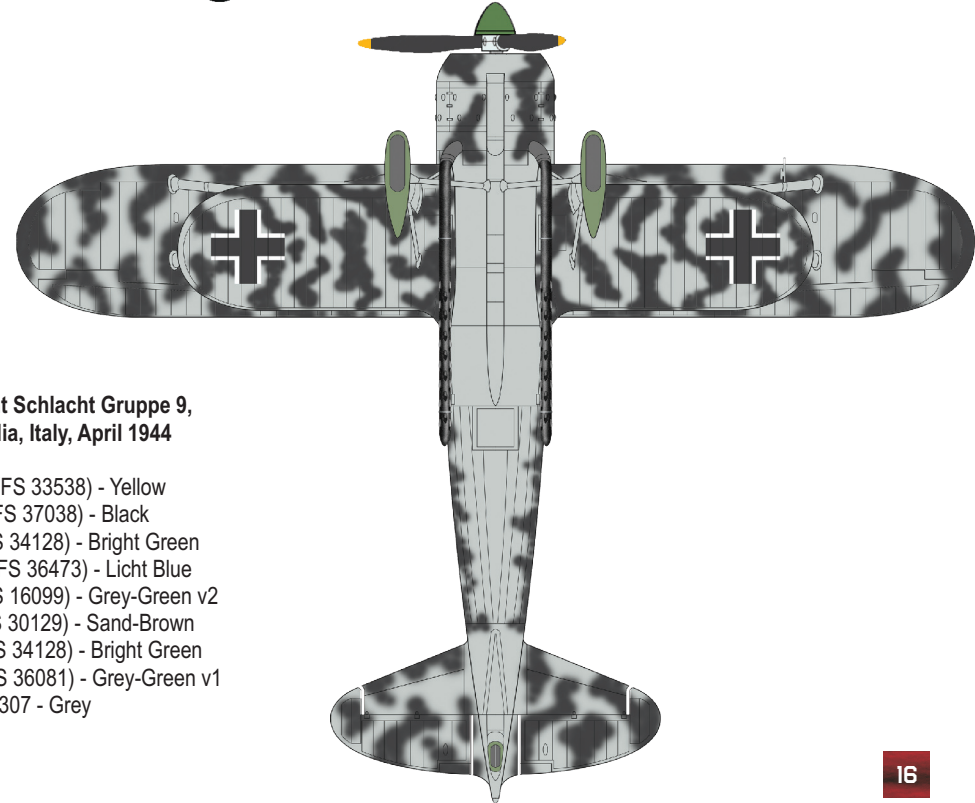
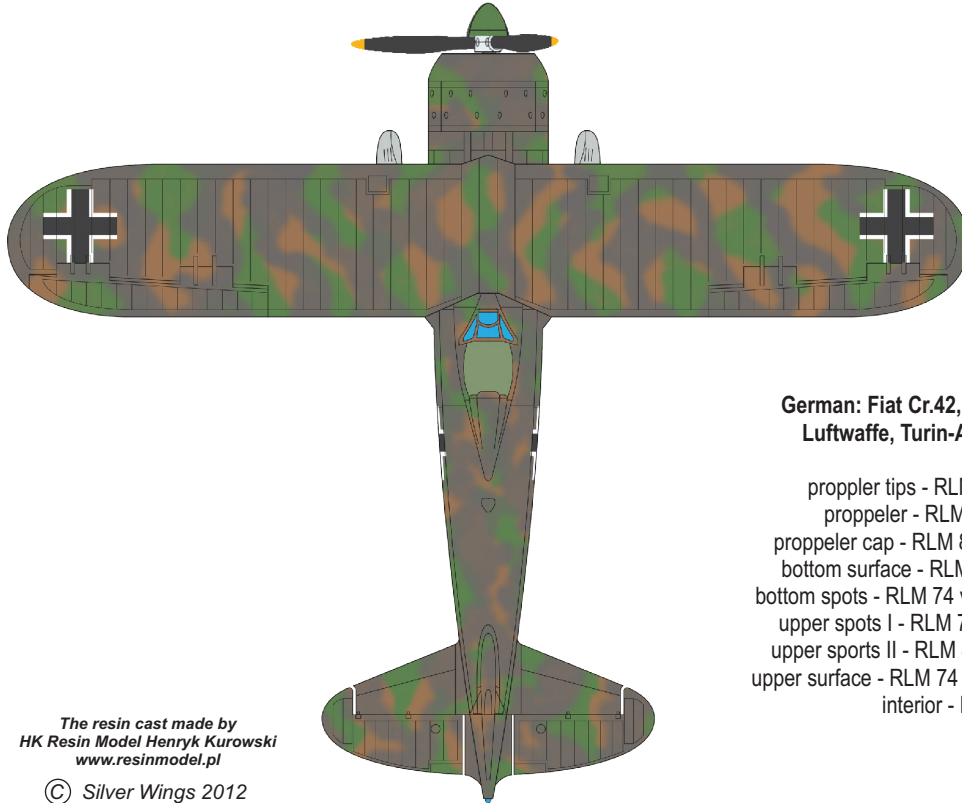

**German: Fiat Cr.42, Nacht Schlacht Gruppe 9,
Luftwaffe, Turin-Aeritalia, Italy, April 1944**

- propeller tips - RLM 04 (FS 33538) - Yellow
- propeller - RLM 22 (FS 37038) - Black
- propeller cap - RLM 82 (FS 34128) - Bright Green
- bottom surface - RLM 76 (FS 36473) - Licht Blue
- bottom spots - RLM 74 v2 (FS 16099) - Grey-Green v2
- upper spots I - RLM 79 (FS 30129) - Sand-Brown
- upper spots II - RLM 82 (FS 34128) - Bright Green
- upper surface - RLM 74 v1 (FS 36081) - Grey-Green v1
- interior - FS 36307 - Grey