

EagleCals
EC#174

1/32
 1/48 1/72

Spitfire Mk.Ia

eagle
EDITIONS LTD.



KL•B (N3180) , No. 54 Sqn.



QV•I (X4474), No. 19 Sqn.



LZ•N (R6800), No. 66 Sqn.

EagleCals EC#174 • © 2020 Eagle Editions Ltd.

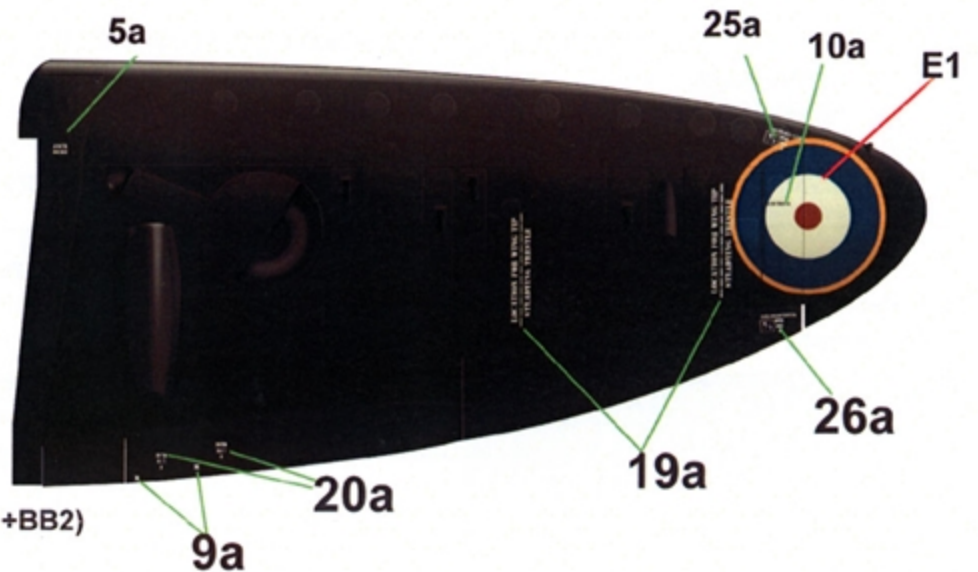
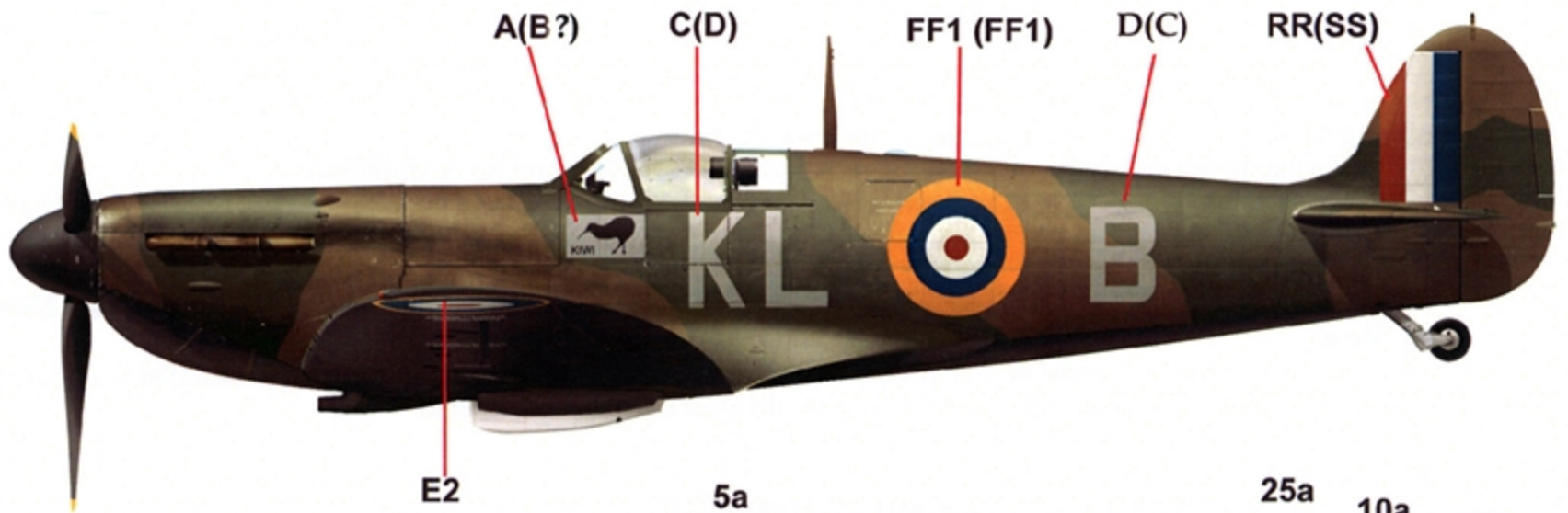

Extra white stencil
decals are provided —
just in case.

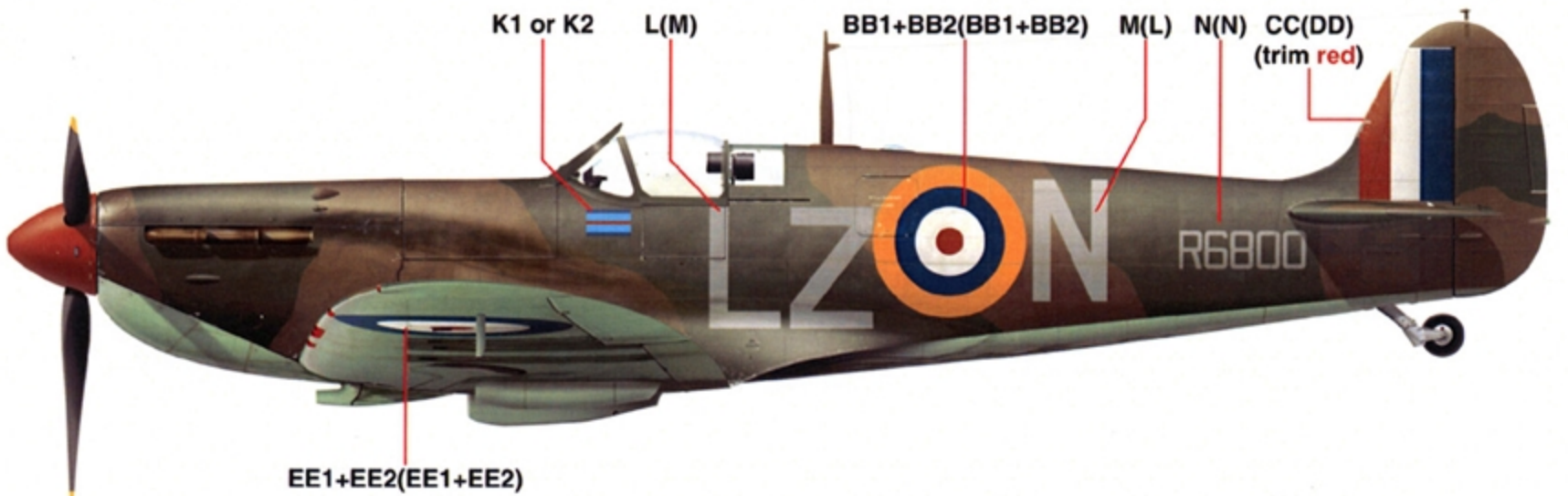
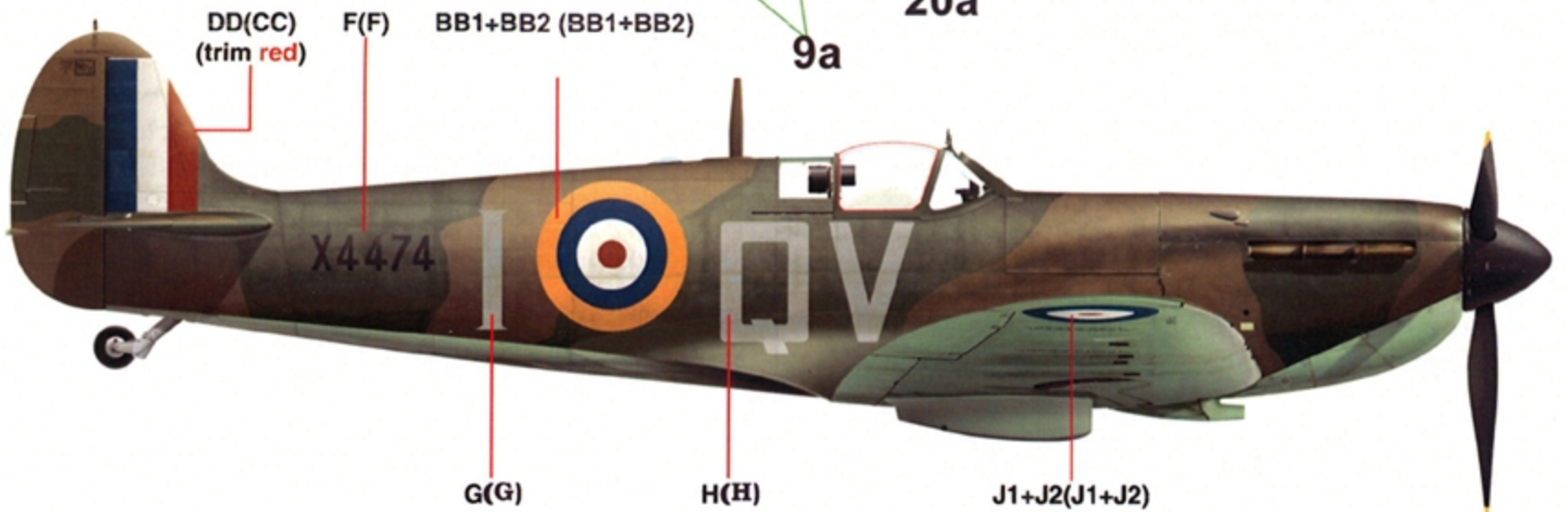

KL•B

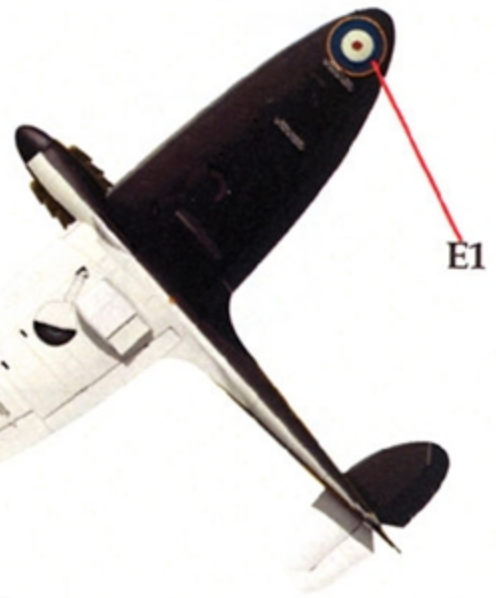
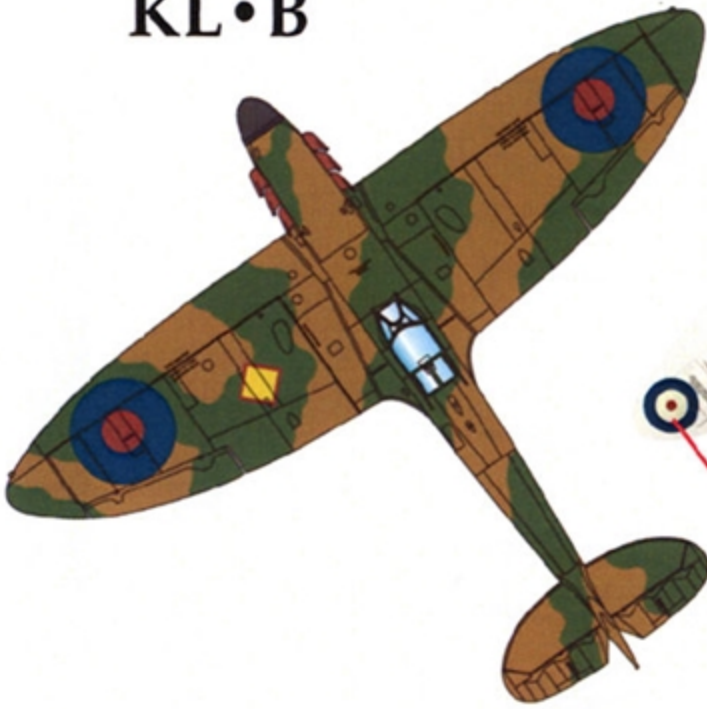

E2

◀ QV•I ▼

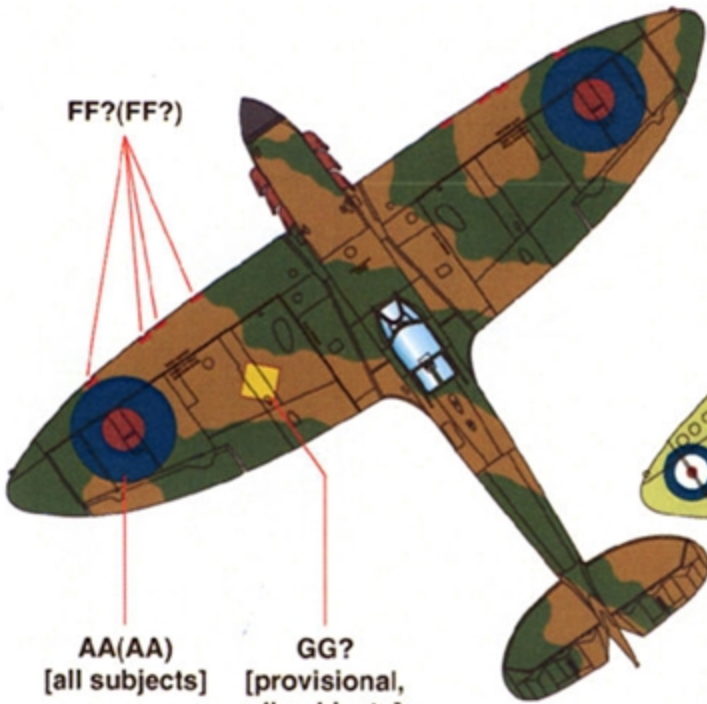

FF?(FF?)

AA(AA)
[all subjects]

GG?
[provisional,
all subjects]

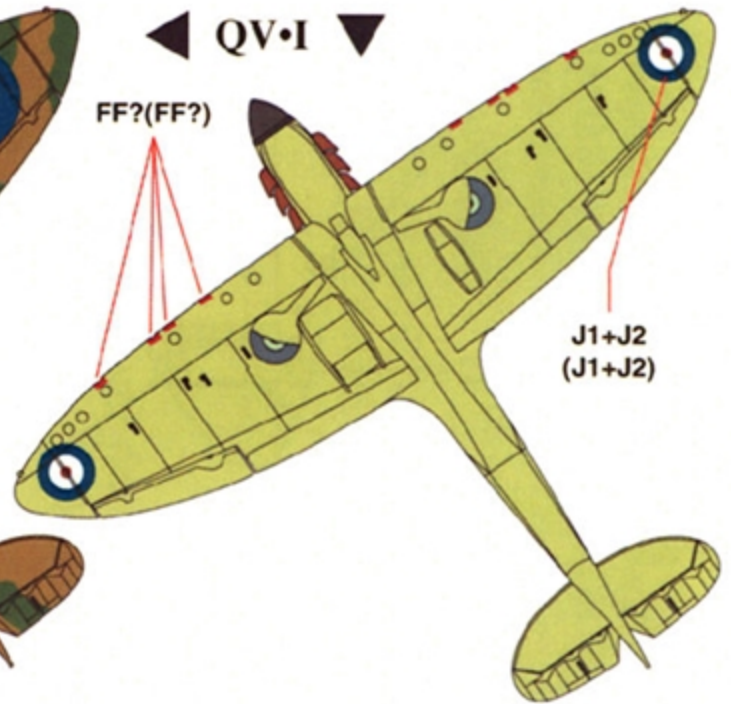

FF?(FF?)

J1+J2
(J1+J2)

◀ LZ•N ▼

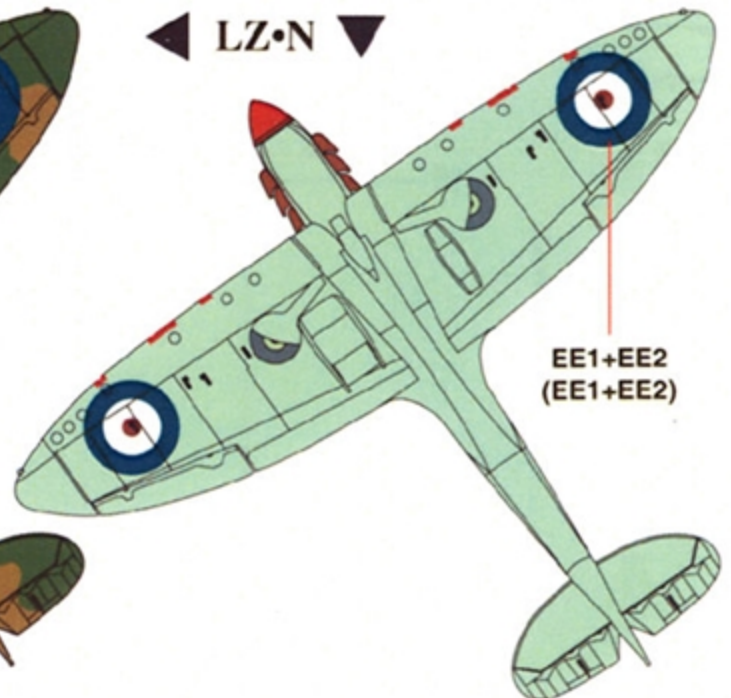

EE1+EE2
(EE1+EE2)

Provisional markings are supplied. Check your references for selections.

**Note: "?"
Denotes
Provisional
Markings**

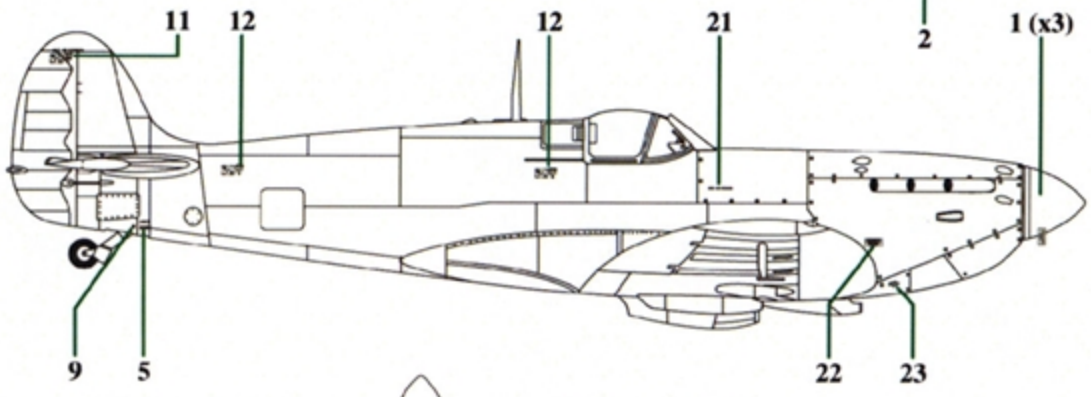
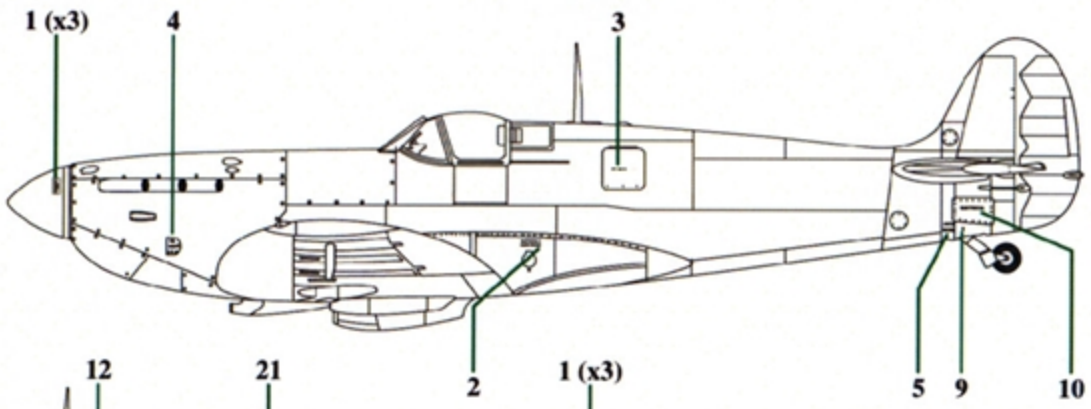

**Provisional
Decals "FF"
Cover
Wing Gun
Openings
(Check
References)**

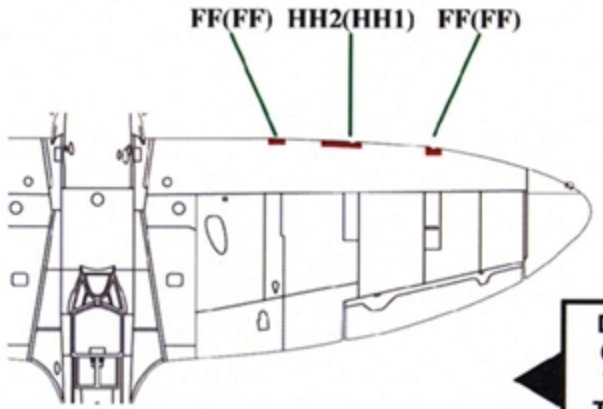
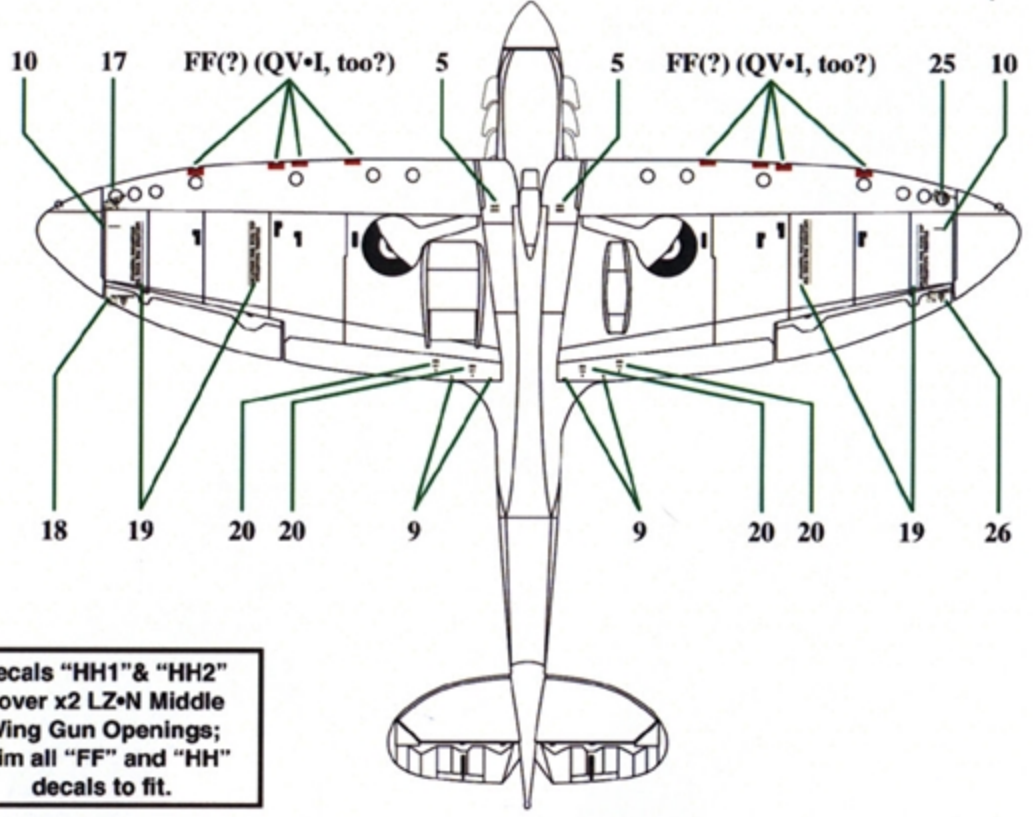
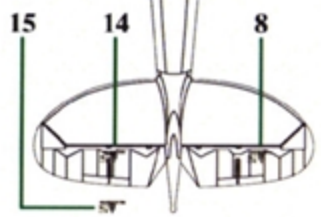
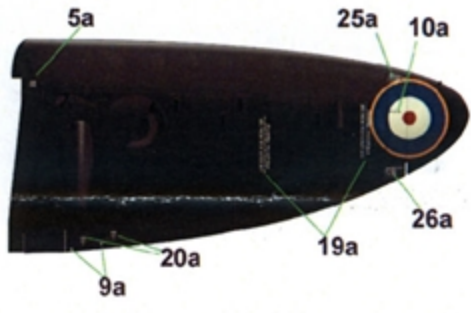
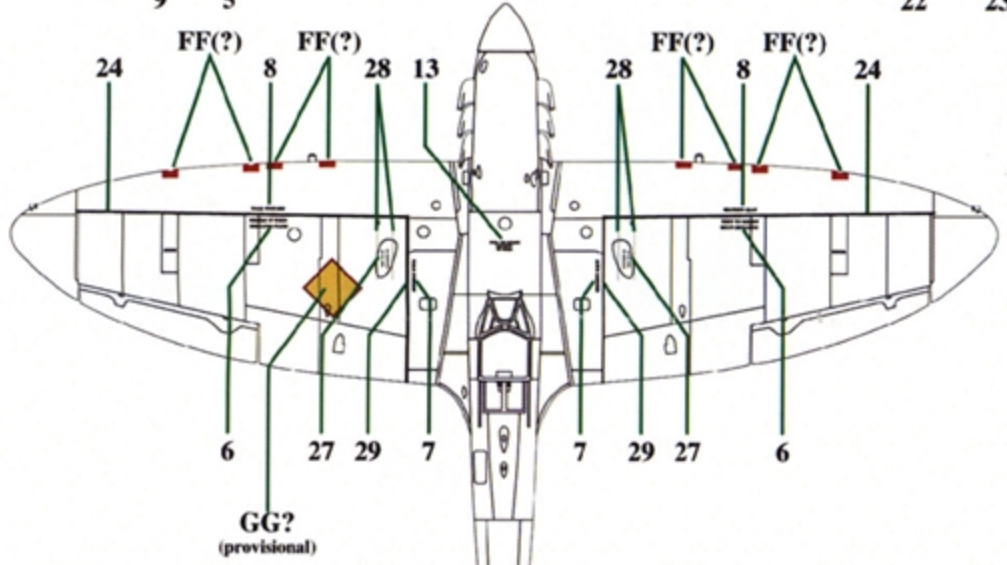

**Decals "HH1" & "HH2"
Cover x2 LZ•N Middle
Wing Gun Openings;
Trim all "FF" and "HH"
decals to fit.**

EagleCals EC#174 • © 2019 Eagle Editions Ltd.

Insignia omitted for clarity. See detail notes for additional markings placement information.

The Supermarine Spitfire is arguably among the most iconic designs to emerge from the Second World War. It achieved legendary status during the Battle of Britain and remained in front line use for the duration of the war in many subsequent variations. Its unique elliptical wing design makes the aircraft easily recognizable to even the most novice historian. The Spitfire and its many variations have been well served by many model companies in all popular scales. A large number of aftermarket items are also available.

KL-B **N3180** **Kiwi** **No. 54 Sqn.** **23 May 1940**

Pilot: P/O Al Deere.

Notes: No antenna wire fitted to later aerial mast. Equipped with Rotol propeller. Starboard Kiwi marking is included as optional.

Colors: Upper surfaces: Temperate Land Scheme of Dark Earth and Dark Green in "B" scheme.

Lower surfaces: Left half: Black. Right half: White. Spinner: Black.

National Insignia: Upper surfaces: 56 inch diameter. Lower surfaces: Provisional depicted as no known photos exist. However, other squadron Spitfires photographed downed on the beach at Dunkirk show roundels were applied at the extreme outboard of the wing.

Fuselage: Non-Standard Red/White/Blue /Yellow roundel.

References: EE private photos

Wingleader Photo Archive Number 1: Supermarine Spitfire Mk I in RAF Service

QV-I **X4474** **No. 19 Sqn.** **Sept. 1940**

Pilot: Sgt. Bernard Jennings.

Notes: No antenna wire fitted to later aerial mast.

Colors: Upper Surfaces: Temperate Land Scheme of Dark Earth and Dark Green in "A" scheme.

Lower Surfaces: Duck Egg Green in variation of Sky. Spinner: Black.

National Insignia: Upper surfaces: 56 inch diameter. Lower surfaces: 30 inch roundel near the wing tips. Fuselage: 35 inch Red/White/Blue/Yellow roundel.

References: Combat Colors No. 8: Supermarine Spitfire in World War II

Osprey Aircraft of the Aces 12: Spitfire Mark I/II Aces 1939-41

LZ-N **R6800** **No. 66 Sqn.** **October 1940**

Pilot: S/L Rupert "Lucky" Leigh. Shot down by Werner Molders on 17 October 1940 with American P/O Hugh Reilly KIA.

Colors: Upper surfaces: Temperate Land Scheme of Dark Earth and Dark Green in "B" scheme.

Lower surfaces: Duck Egg Blue (Provisional). Spinner: Red.

National Insignia: Upper surfaces: 56 inch diameter. Lower surfaces: 50 inch Red/White/Blue.

Fuselage: 35 inch Red/White/Blue/Yellow roundel.

References: American Eagles: American Volunteers in the RAF 1937-1943

Osprey Aircraft of the Aces 12: Spitfire Mark I/II Aces 1939-41

*With special thanks to Mark Proulx for research and proofing
Color aircraft profiles by James Bentley*

© 2020 Eagle Editions Ltd. All images/photos copyrighted by
Eagle Editions Ltd. LLC
752 Bobcat Lane Hamilton MT 59840
www.eagle-editions.com

No copies may be reproduced without written consent from publisher Eagle Editions Ltd. LLC
The color schemes depicted are the artist's interpretations of the available photographic references only.
The final decision resides with the modeler.