

# 21 cm Mörser 18 "Matterhorn"



Vývoj započal v roce 1933, první kompletní zbraň byla zařazena do služby v roce 1939. Dělo bylo používáno ve dvou variantách; stejnálafeta jako u 17 cm K18. Výroba byla zastavena v roce 1942 ve prospěch 17 cm K18. Bylo používáno operačně na všech frontách a střílelo širokou řadu munice vyráběné speciálně pro tuto zbraň.

Development began 1933, first complete equipment entered service 1939. Used in two variants; same carriage as 17 cm K18. Production ceased 1942 in favour of 17 cm K18. Used operationally on all fronts and fired wide range of ammunition specially developed for this weapon.

Die Entwicklung begann in 1933, die erste komplette Waffe trat in Dienst in 1939. Wurde in zwei Varianten verwendet; gleiche Lafette wie bei 17 cm K18. Erzeugung beendet in 1942 zu gunsten der 17 cm K18. Angewandt operationell an allen Fronten und schoss einen breiten Umfang von Munition, die speziell für diese Waffe hergestellt wurde.

MV 044

1/72

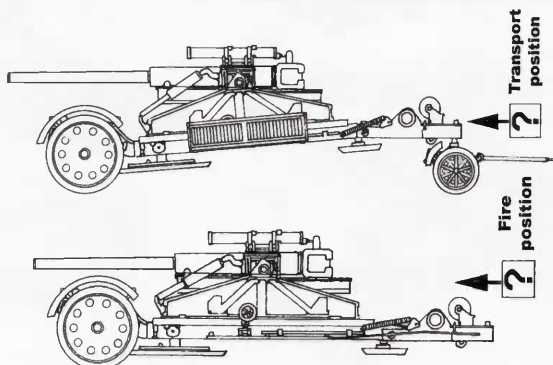

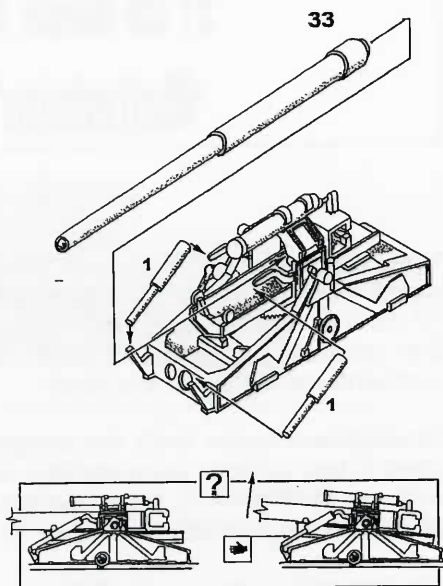
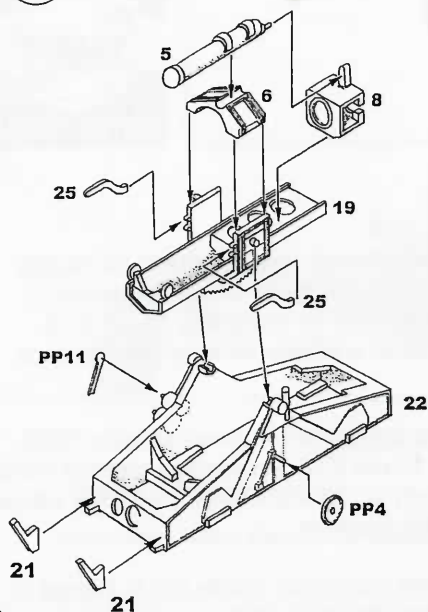
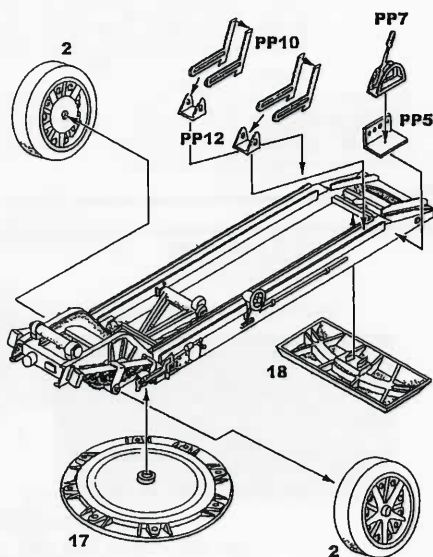
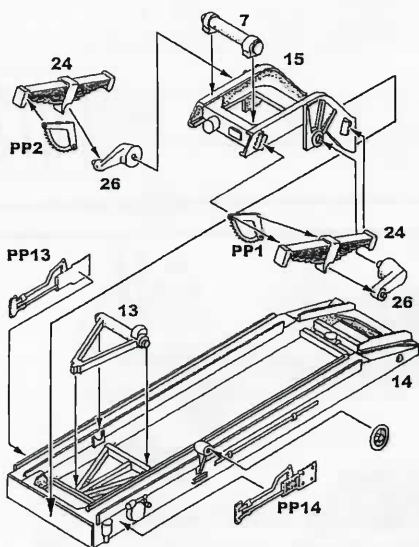
**1****Sestavení kanonu / Cannon assembly / Zusammenbau der Kanone****2****Montáž podvozku / Chassis mounting / Fahrwerkmontage**

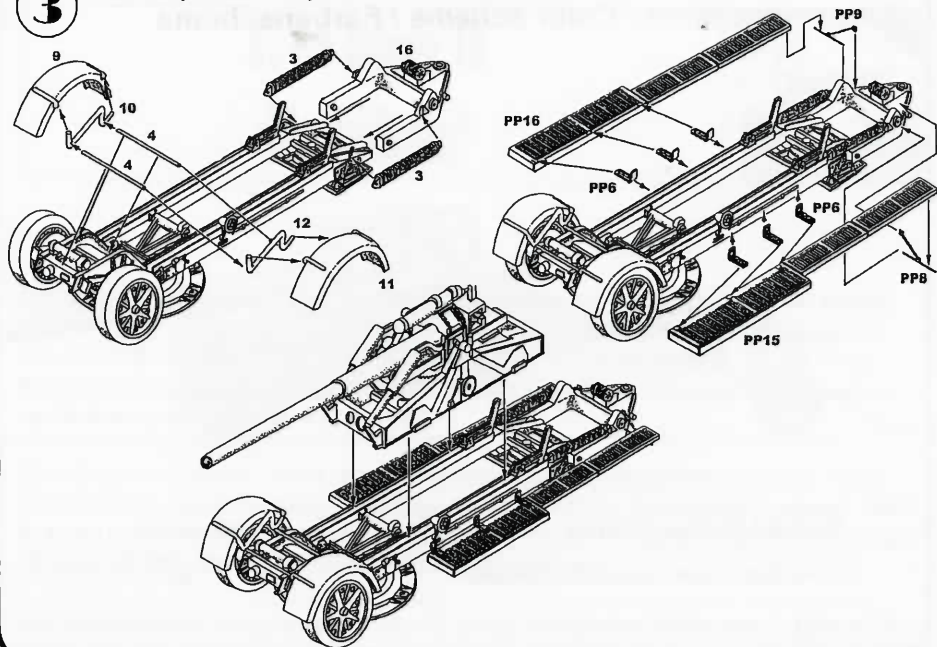
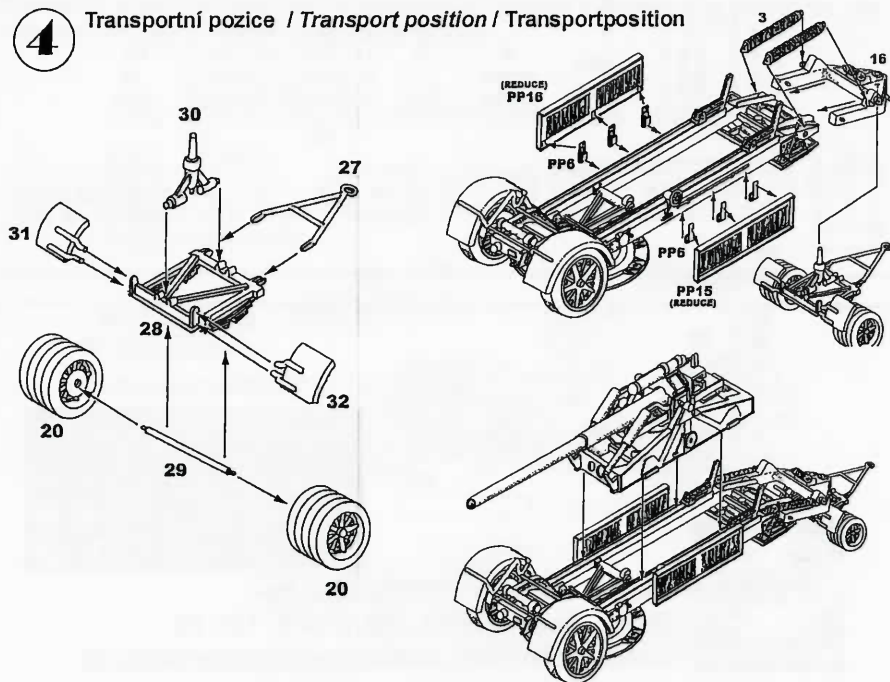
**3****Palebná pozice / Fire position / Schiessstand****4****Transportní pozice / Transport position / Transportposition**

Barevné schéma / Color scheme / Farbenschema

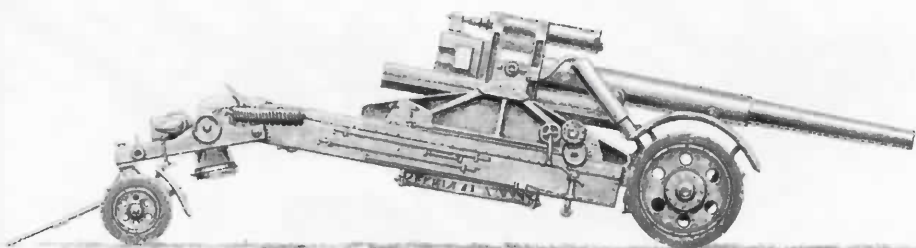

Barva / Colour / Farbe

Humbrol

Tmavá žlutá / Dark Yellow / Dunkelgelb

94

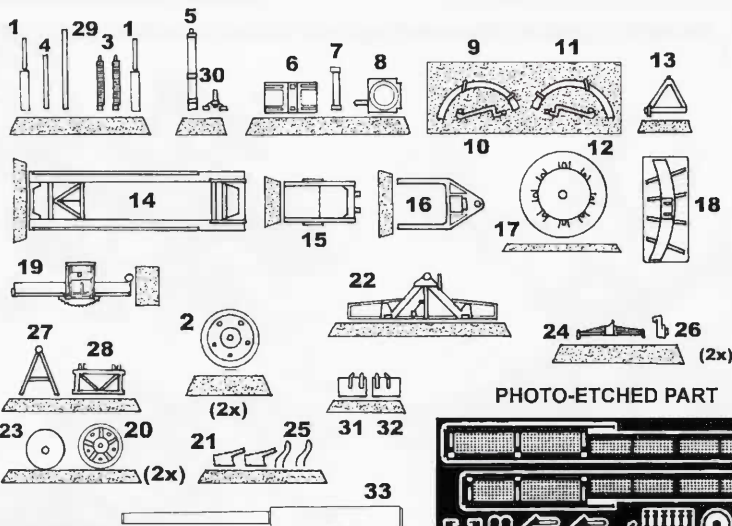

PHOTO-ETCHED PART



Planet models distributors by :  
CMK Mezilesí 718, PRAHA 9 139 00  
Czech Republic, [www.czechmasterskits.cz](http://www.czechmasterskits.cz)