



# PLASTIC AIRCRAFT KIT

## Gloster Meteor NF 11/12/14

1/72 scale

XK7200.

The Gloster Meteor was Britain's first jet day fighter to enter service in World War Two and it remain in front line service in various versions until the later 1950s. Following the end of the war, Armstrong Whitworth was given the responsibility of developing a two-seat version of the Meteor for the night fighter role to replace the aging Mosquito, the second crew member acting as radar operator and navigator. With a lengthened nose housing the airborne interception (AI) radar, and fitted with the early long-span wings which now housed the four 20 mm cannons, the prototype NF11 first flew on 31 May 1950. NF11s entered service with the RAF in 1951 and in 1953 were followed into limited production by the NF12 which had improved AI radar and an increase in fin area. The NF13 was a tropicalised version of the NF11 which served with the RAF in the middle and far east. The final production variant was the NF14 which was an update of the NF12, having a completely revised clear vision cockpit canopy; it was 430 mm longer than the NF11 and entered service in May 1954. By 1961 the Gloster Javelin all-weather fighter had replaced all version of the Meteor night fighter, which had served with 19 front line RAF squadrons. Meteor night fighters saw limited operational use in the middle east, especially during the 1956 Suez crisis; several NF11s were exported to Belgium, Denmark, and France; Egypt, Israel and Syria received limited numbers of NF13s and the sole ex-RAF NF14 export went to France for experimental use. The Meteor NF11 had a wing span of 13,1 m and a length of 14,77 m.

**A**

bronze green, matt  
vert bronze, mat

**B**

grey, matt  
gris, mat

**C**

greyish blue, matt  
gris-bleu, mat

**D**

black, matt  
noir, mat

**E**

Nazi-olive, matt  
olive O.T.A.N., ma

**F**

aluminium, metallic  
aluminium, métallique

**G**

white, matt  
blanc, mat

**H**

carmin red, matt  
rouge carmin, mat

### Used Colours

### Used Symbols



Optional  
Facultatif



Number of working steps  
Nombre d'étapes de travail

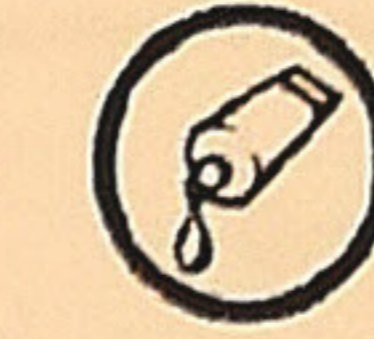

Glue  
Colle



Don't glue  
Ne pas coller



Make a hole  
Faire un trou



Clear parts  
Pièces transparentes



Illustration of assembled parts  
Figure représentant les pièces assemblées



Repeat same procedure on opposite side  
Opérer de la même façon sur l'autre face



20 gr.

Add weight for improved stability  
Pour une mise en place correcte allourdir



Soak and apply decals  
Mouiller et appliquer les décalcomanies

1

(25,26)

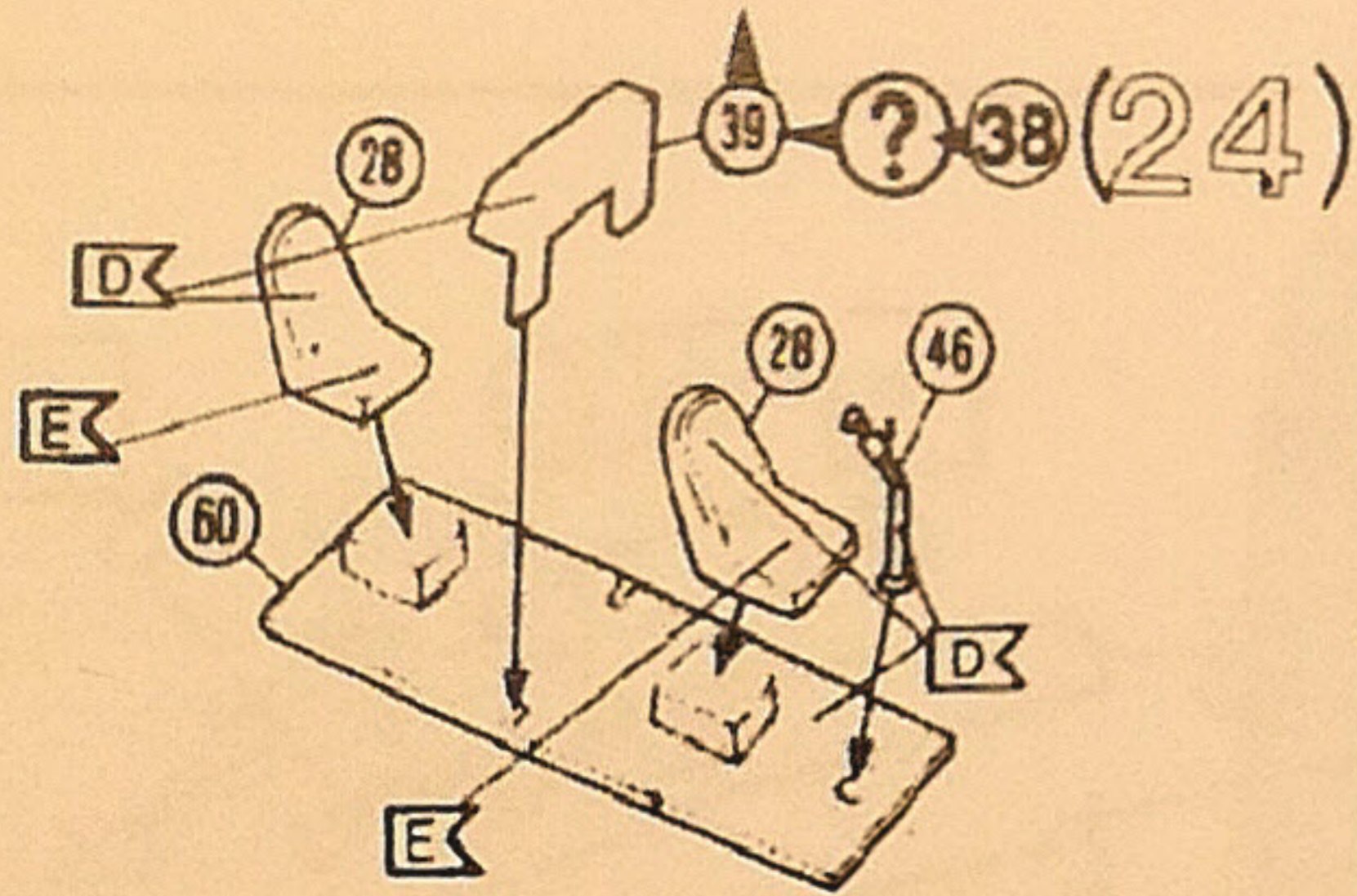

2

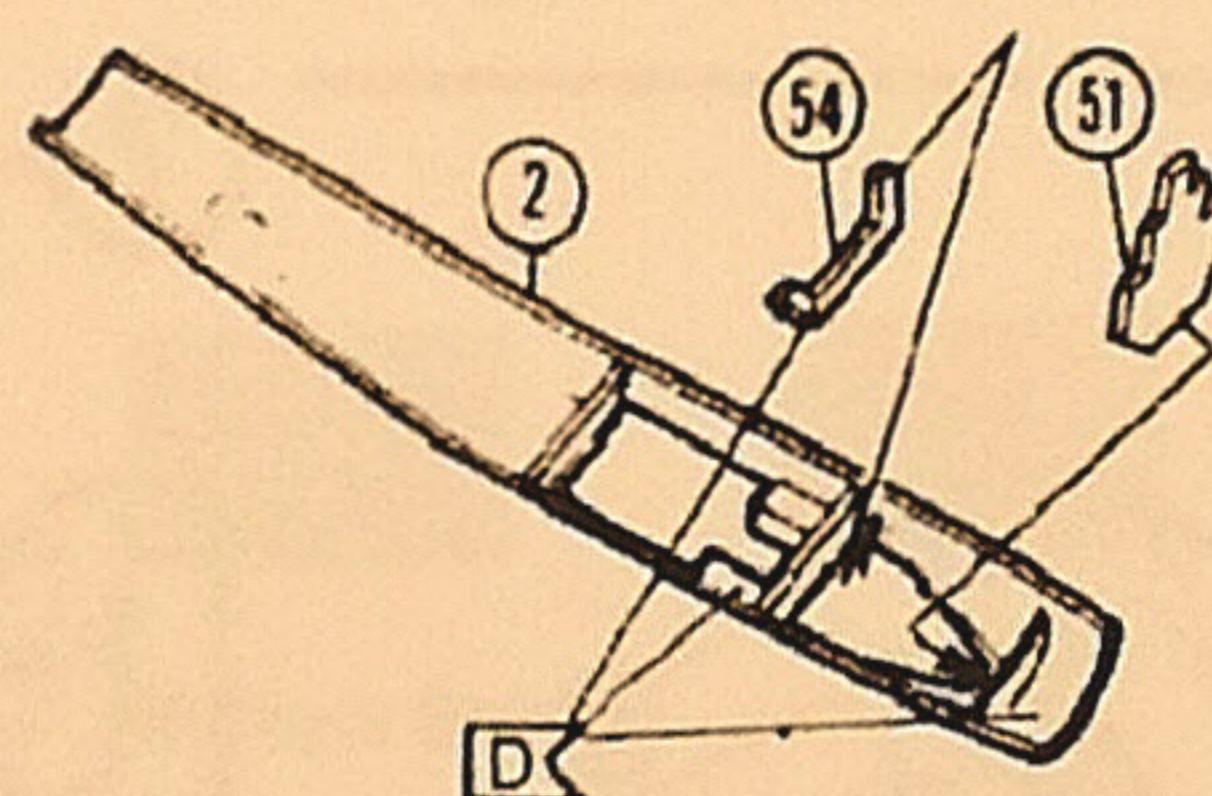

3

? 24,26

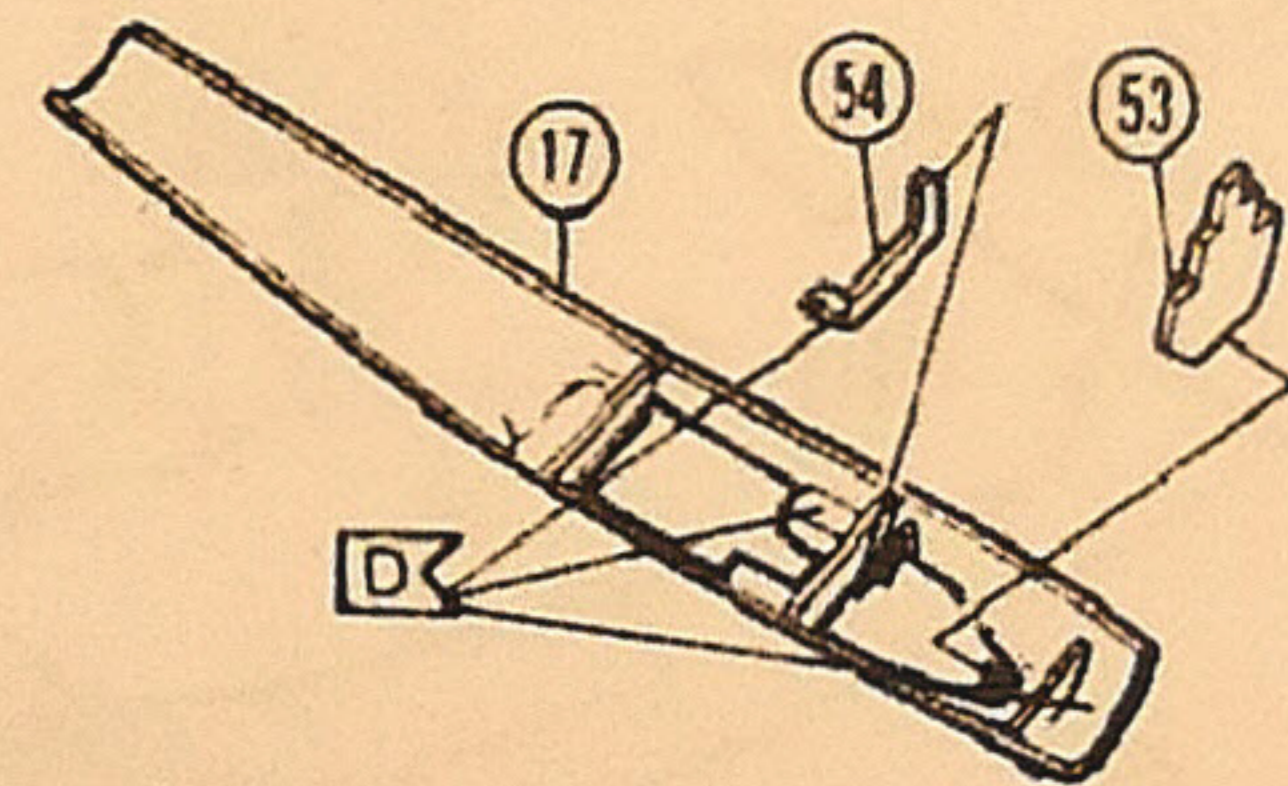

4

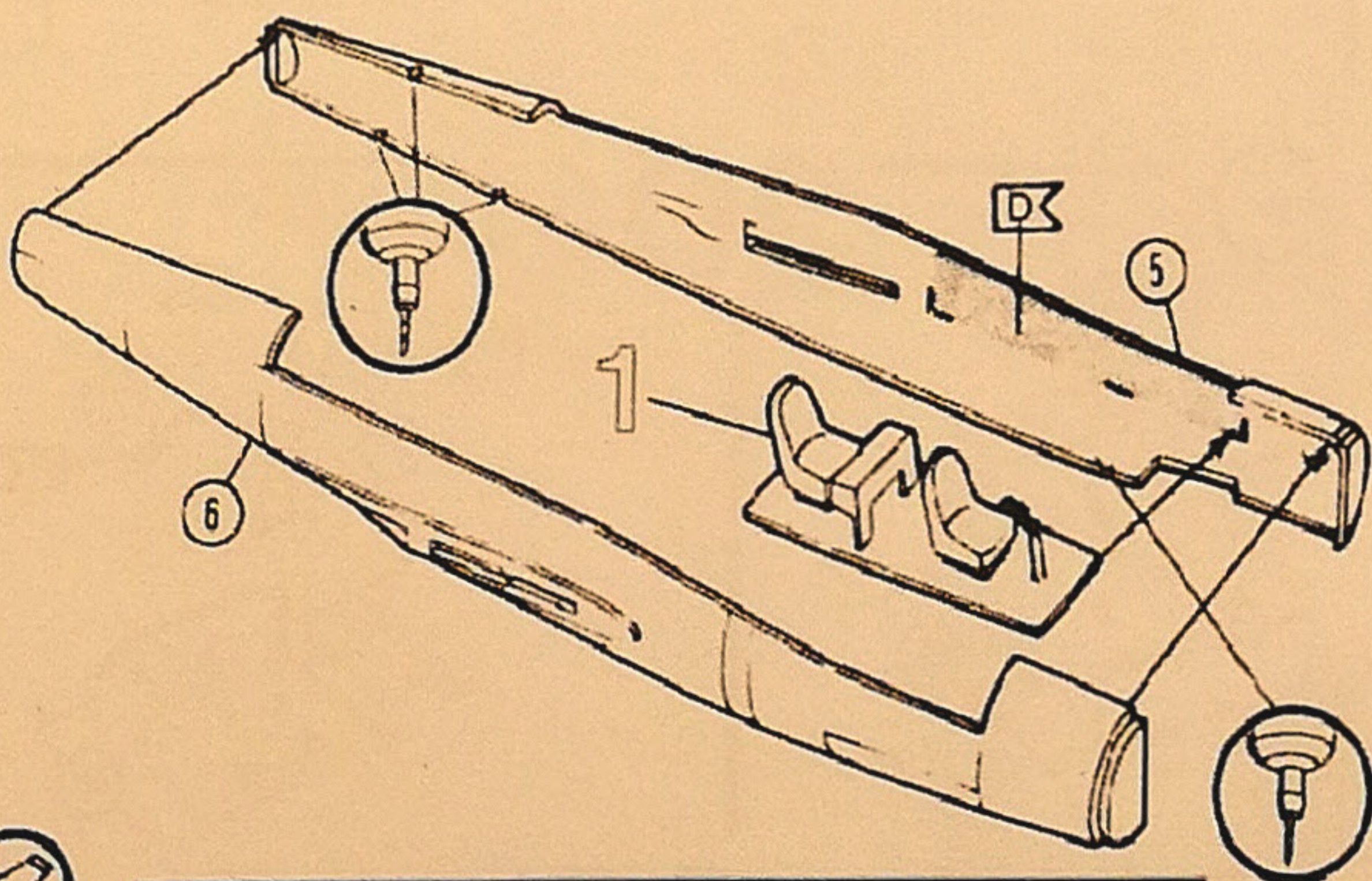

5

? 25, 26

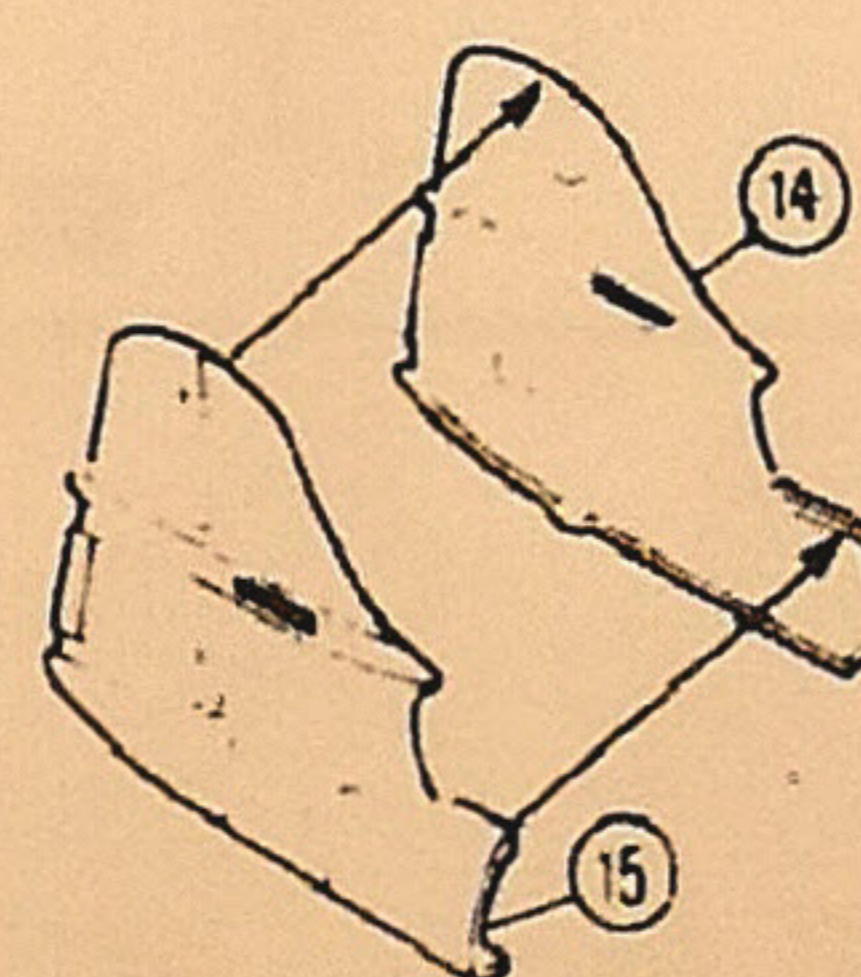

6

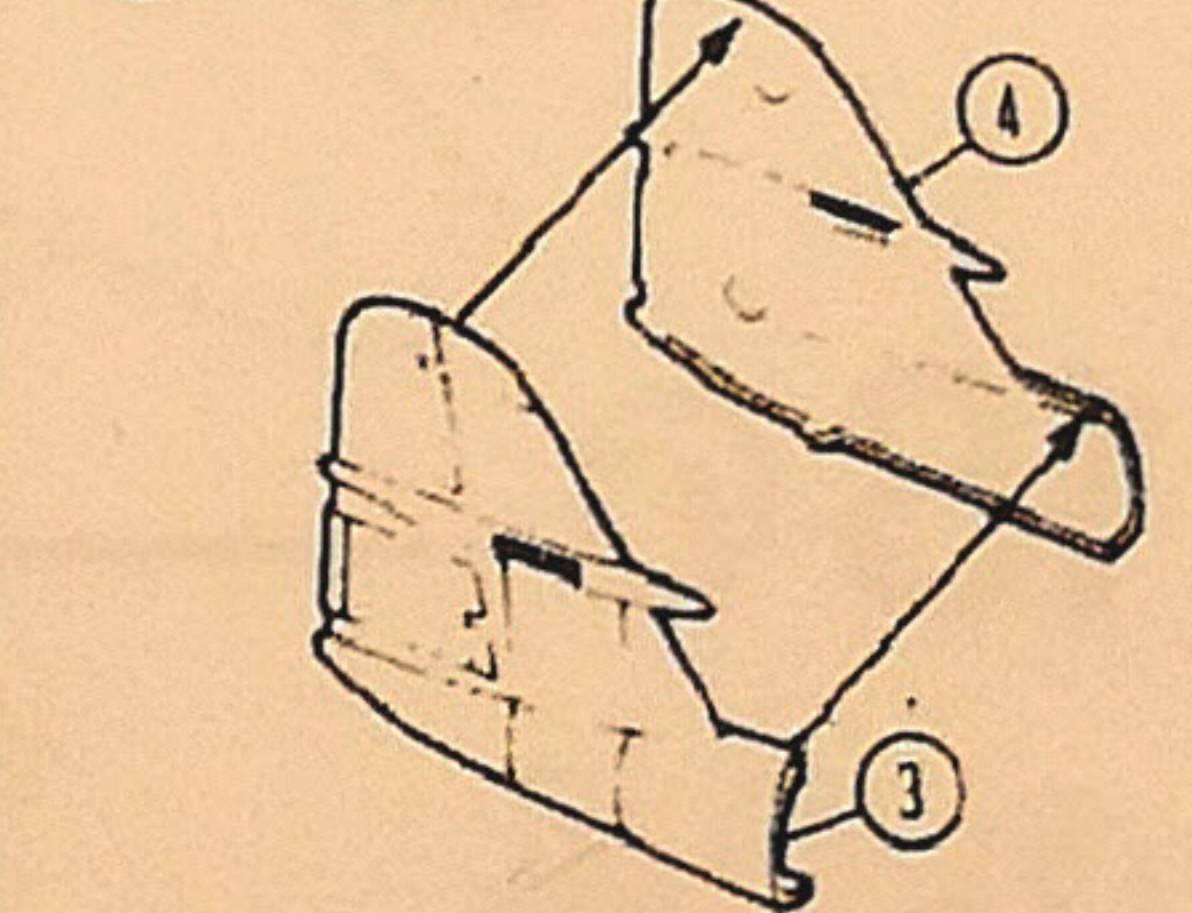

? 24

7

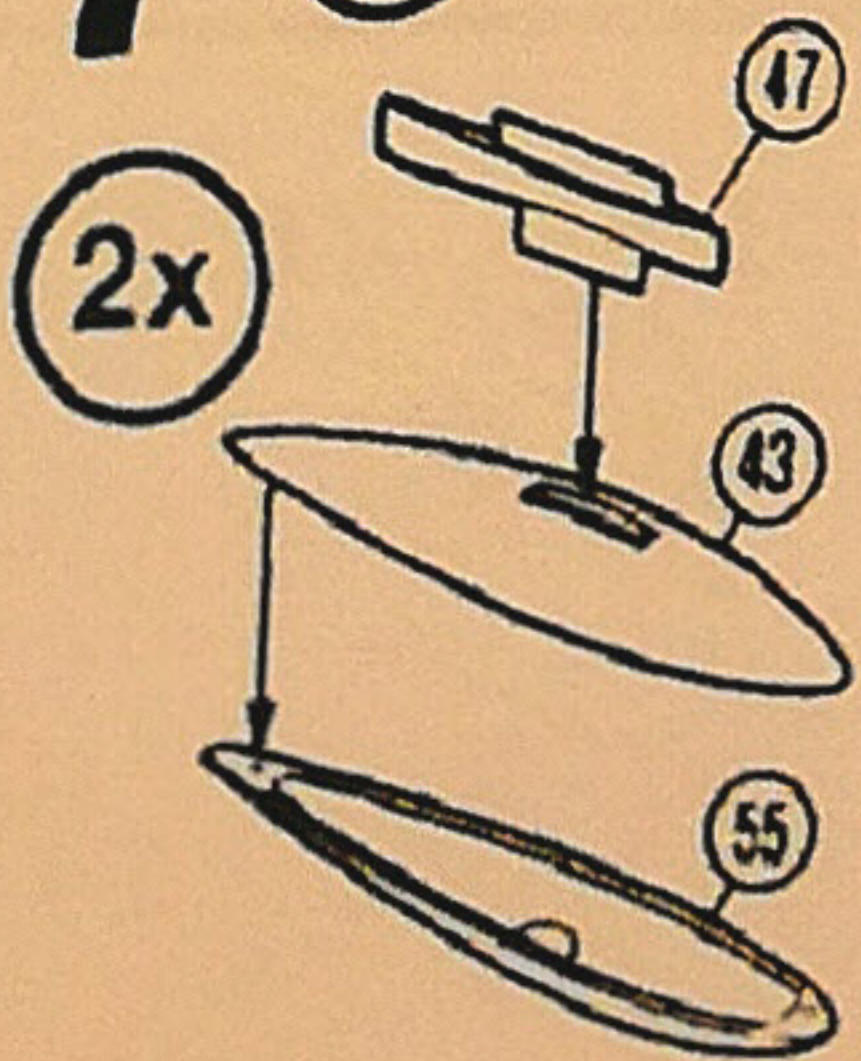

8

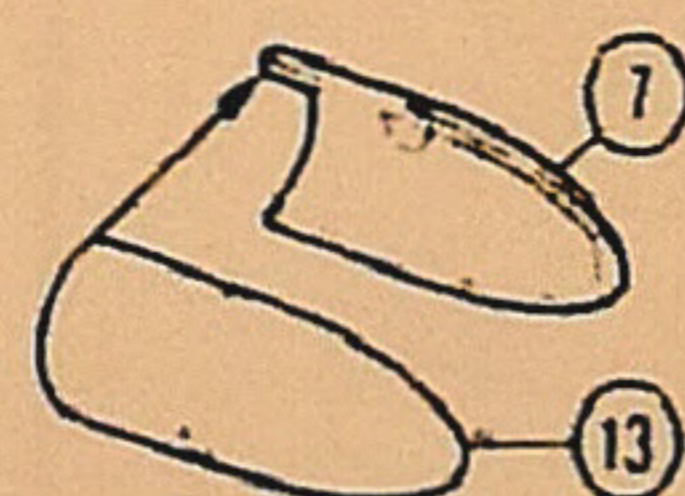

9



10



11

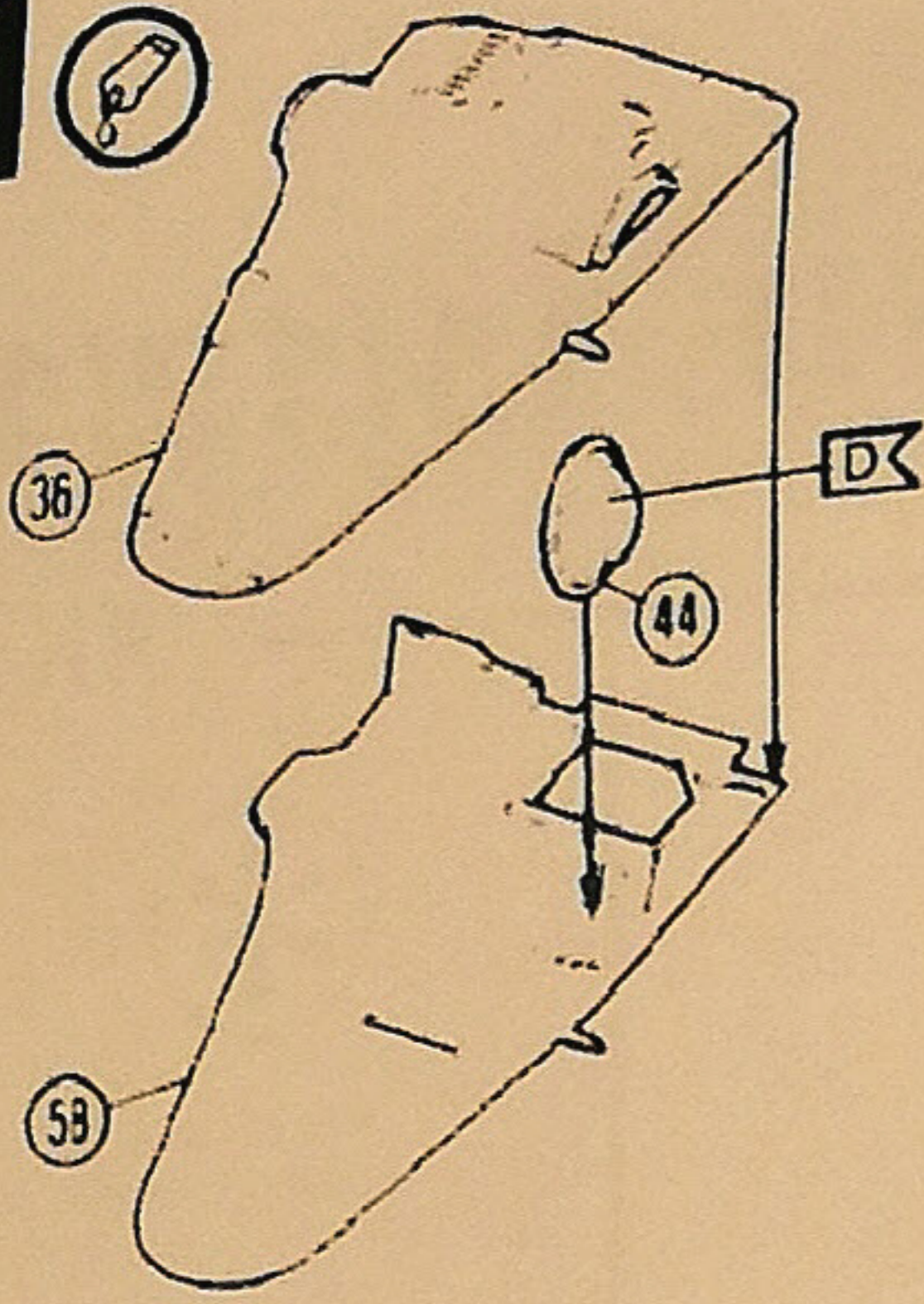

12

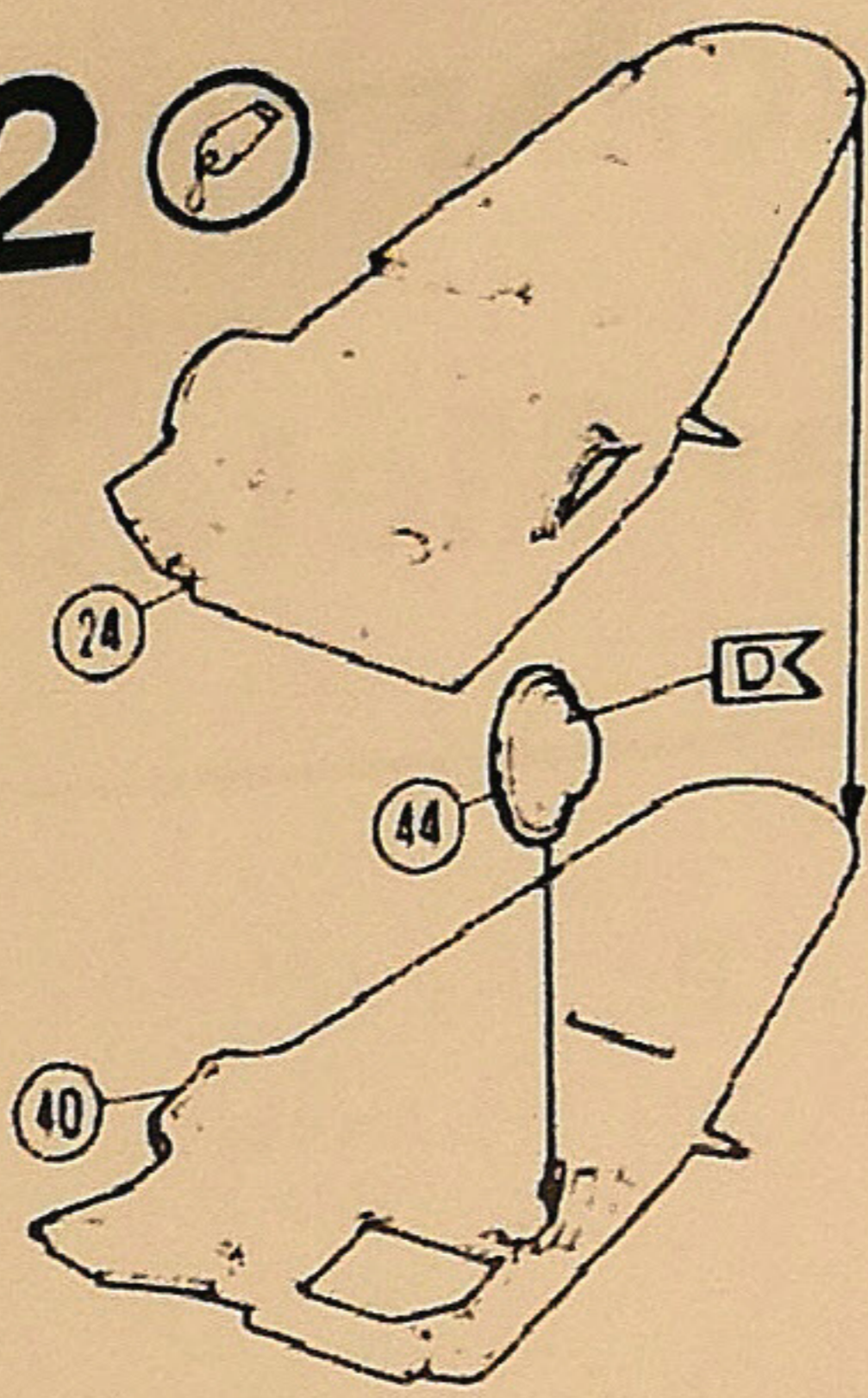

13

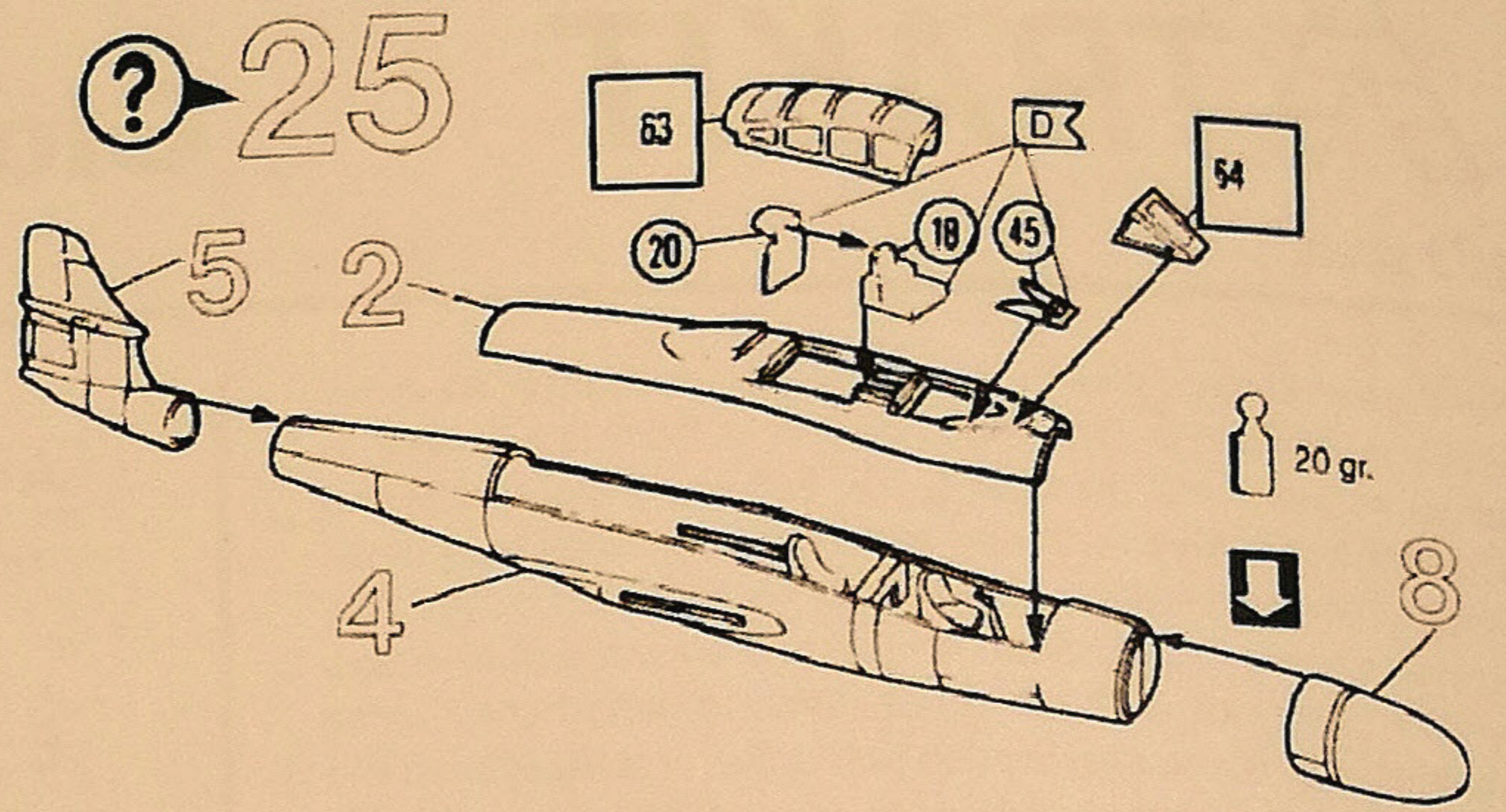

14

25

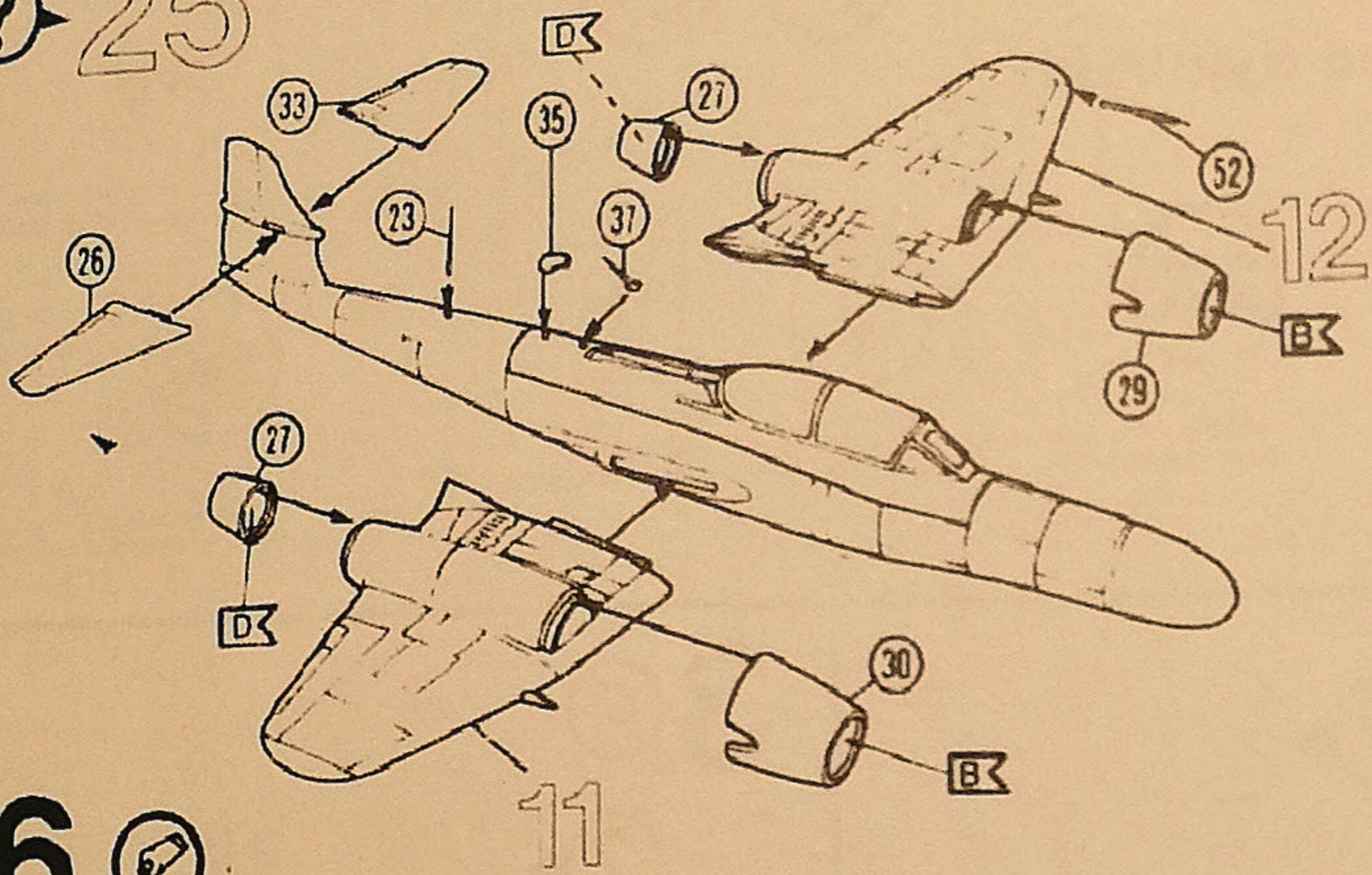

15

26

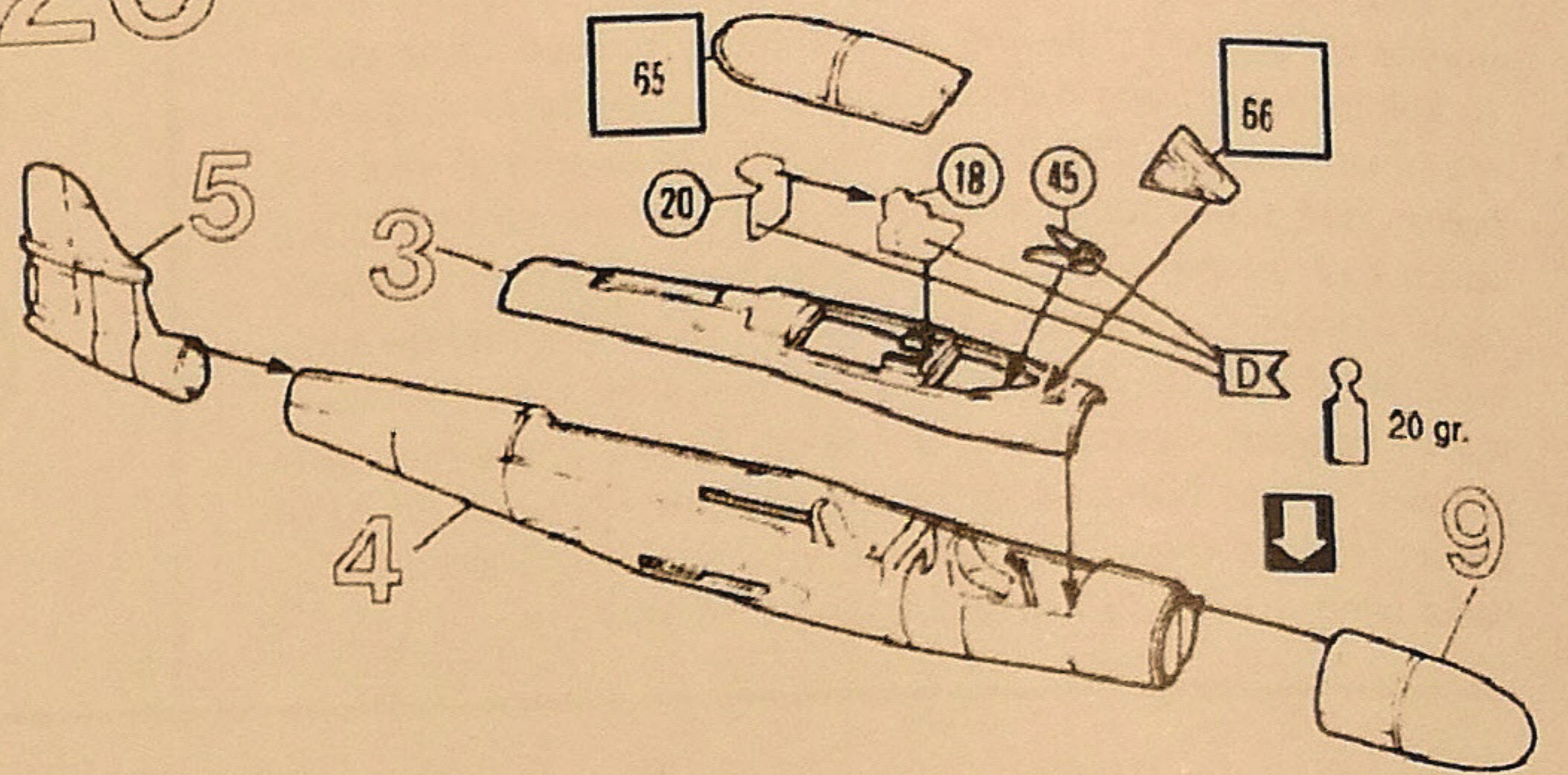

16

26

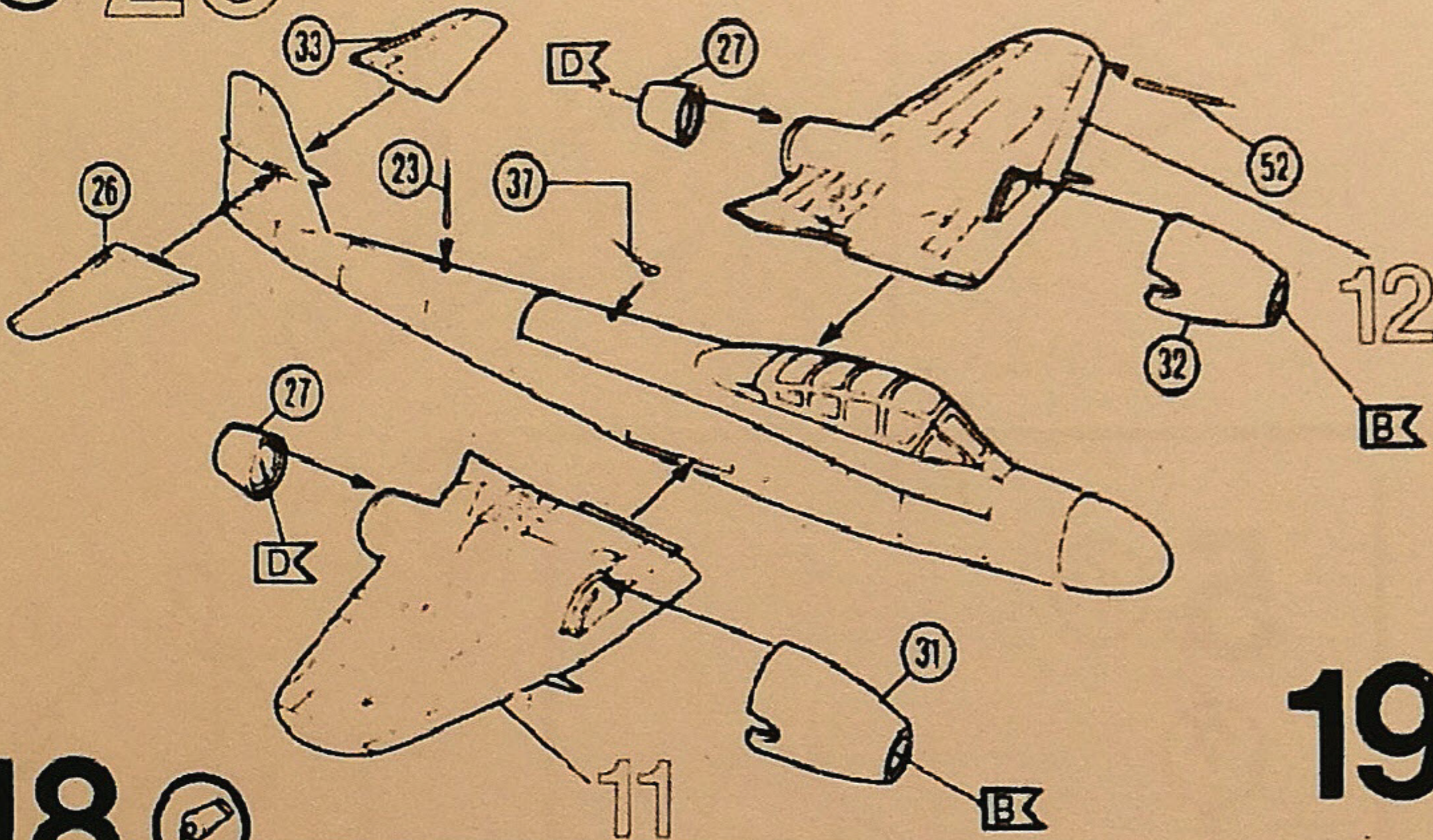

17

24

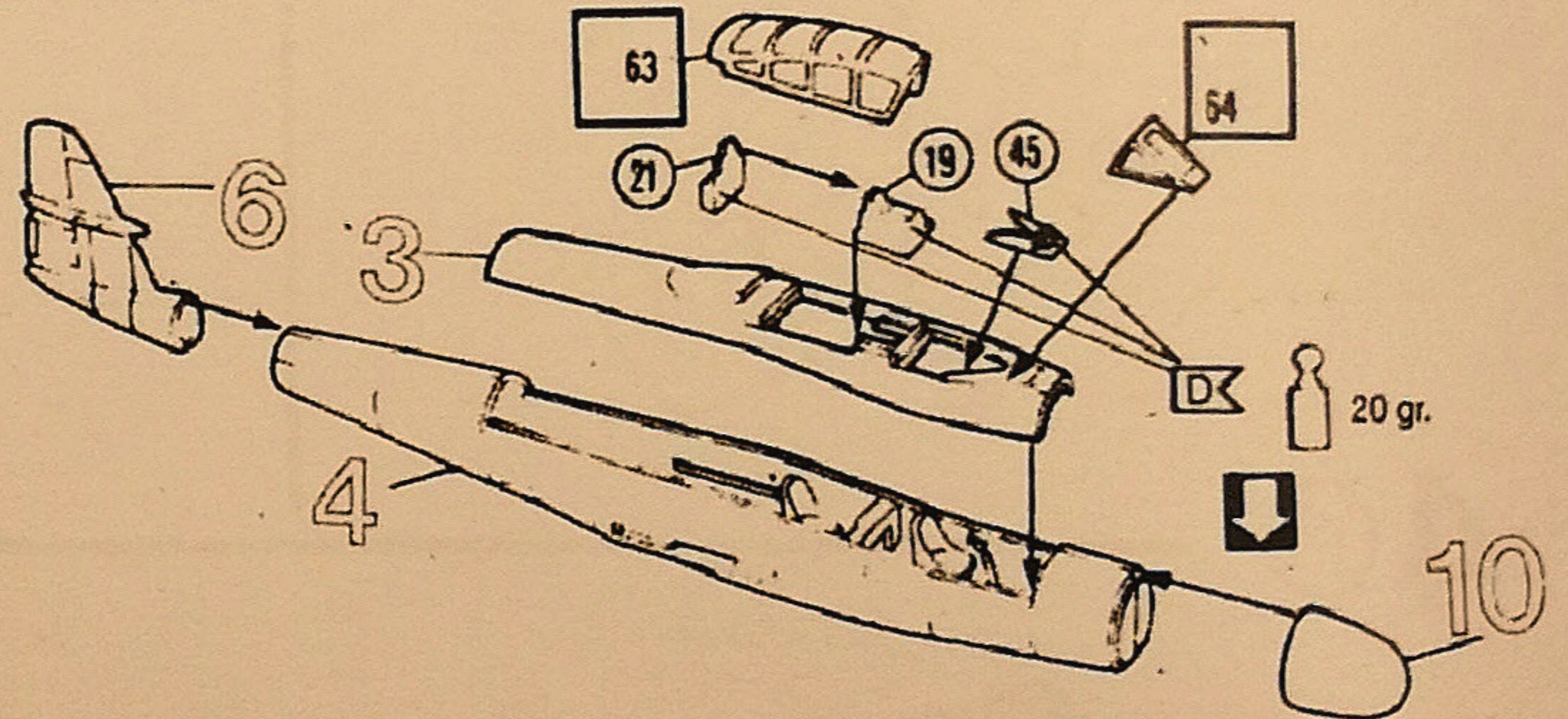

18

24

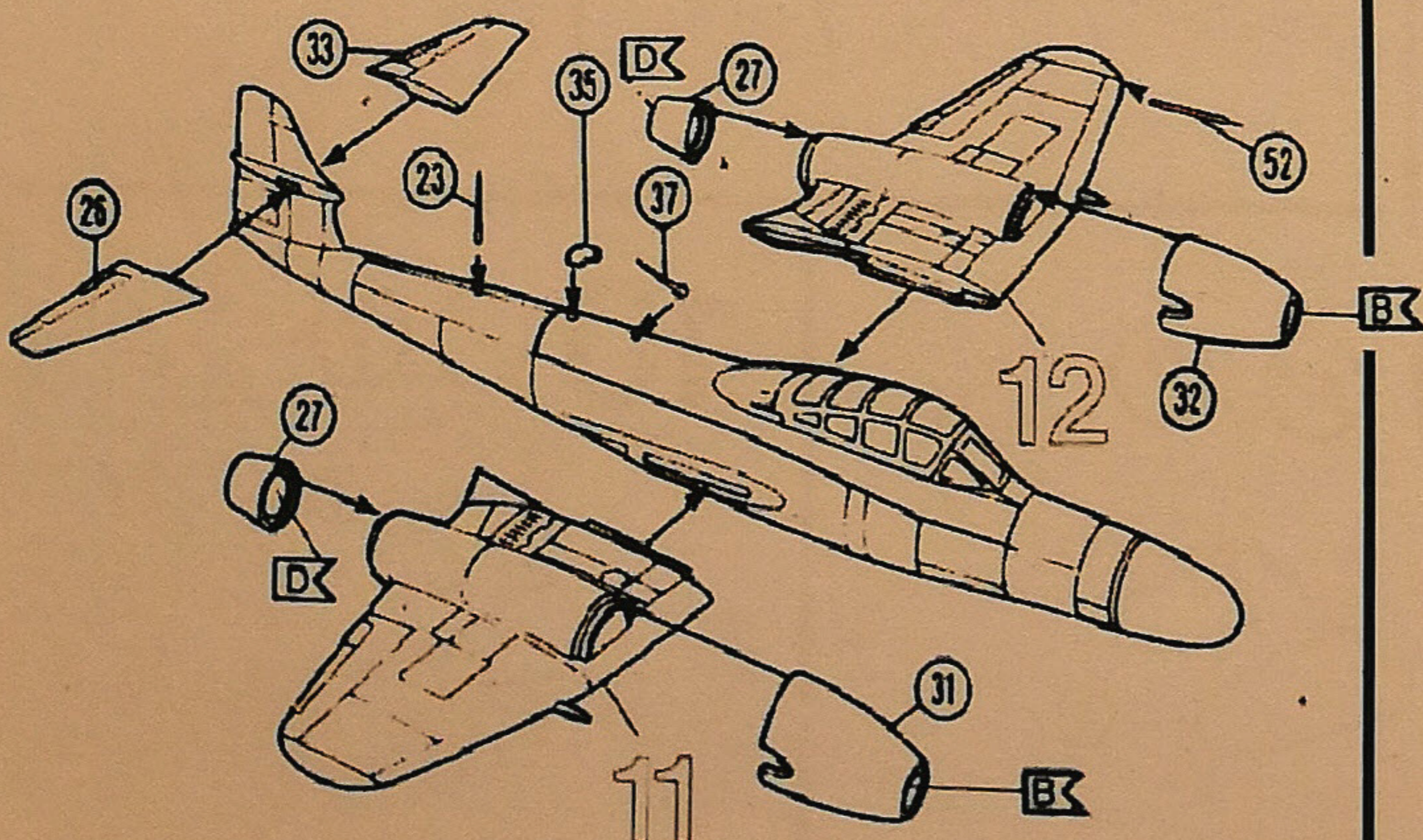

19

20

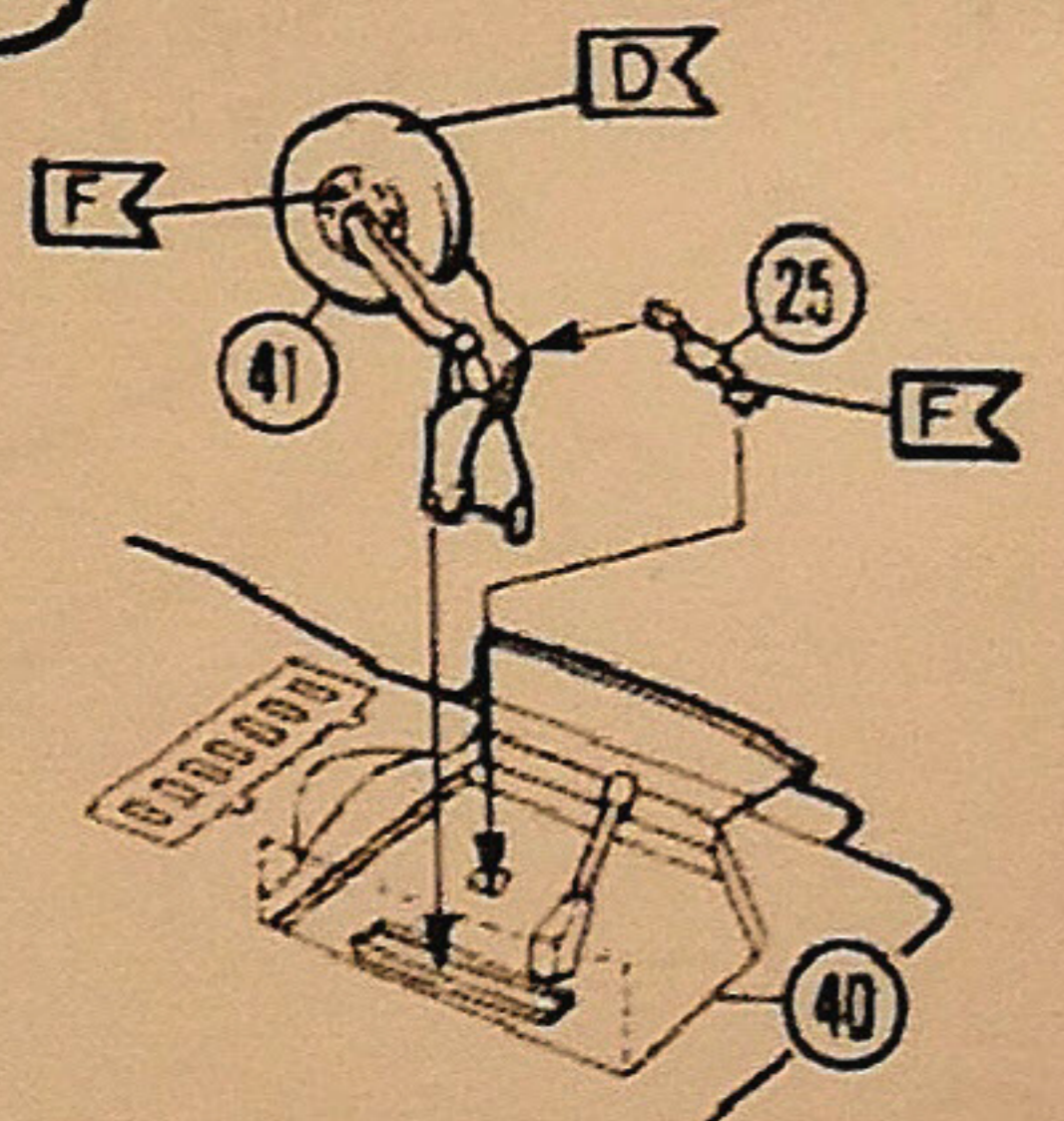
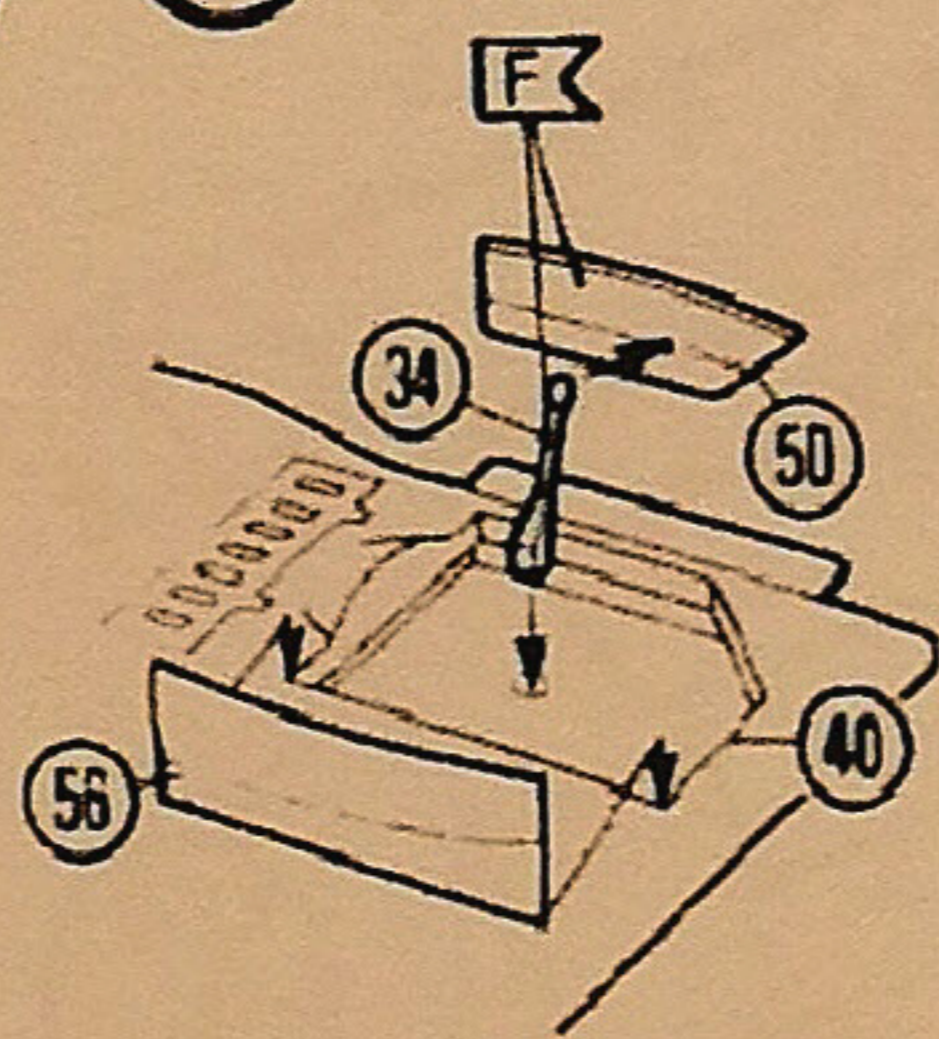

21

22

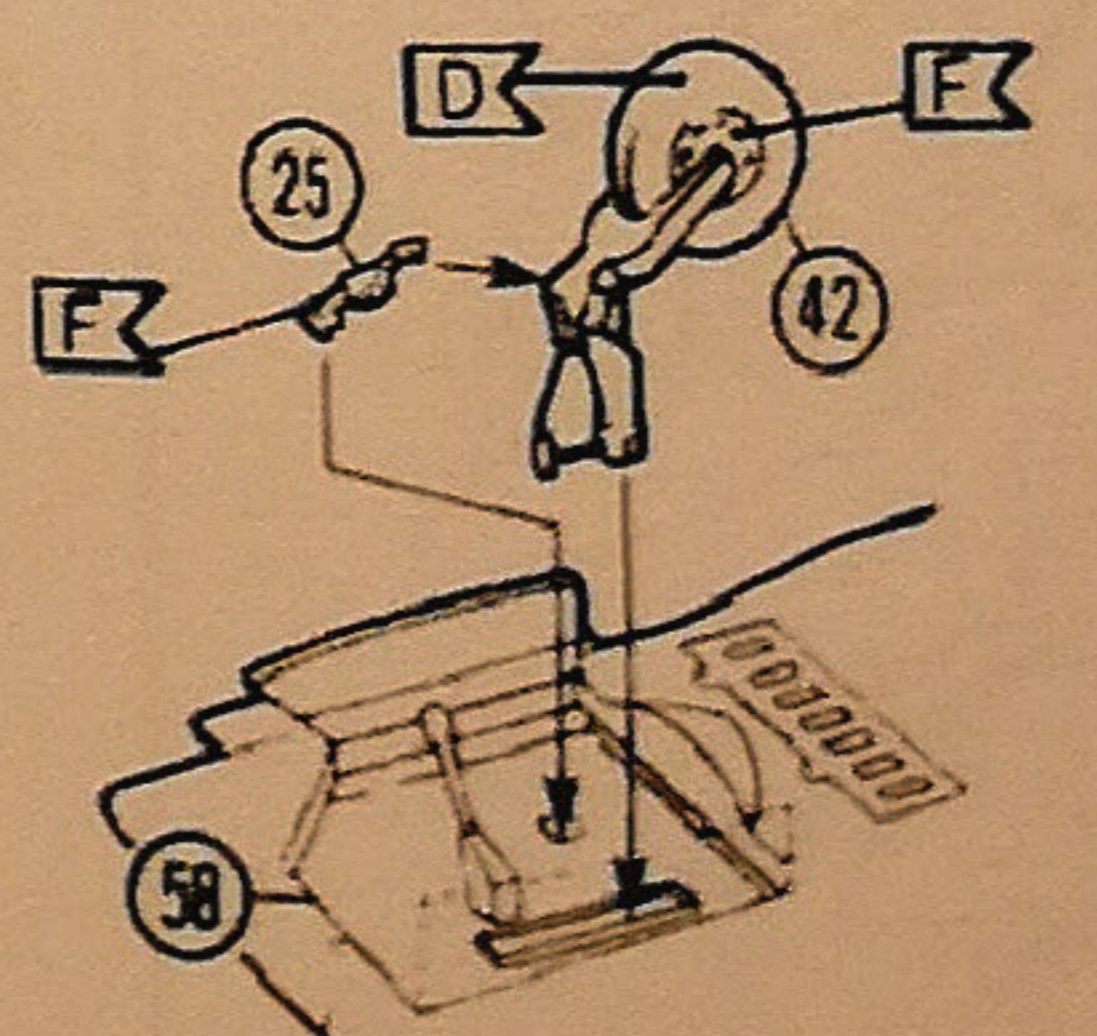
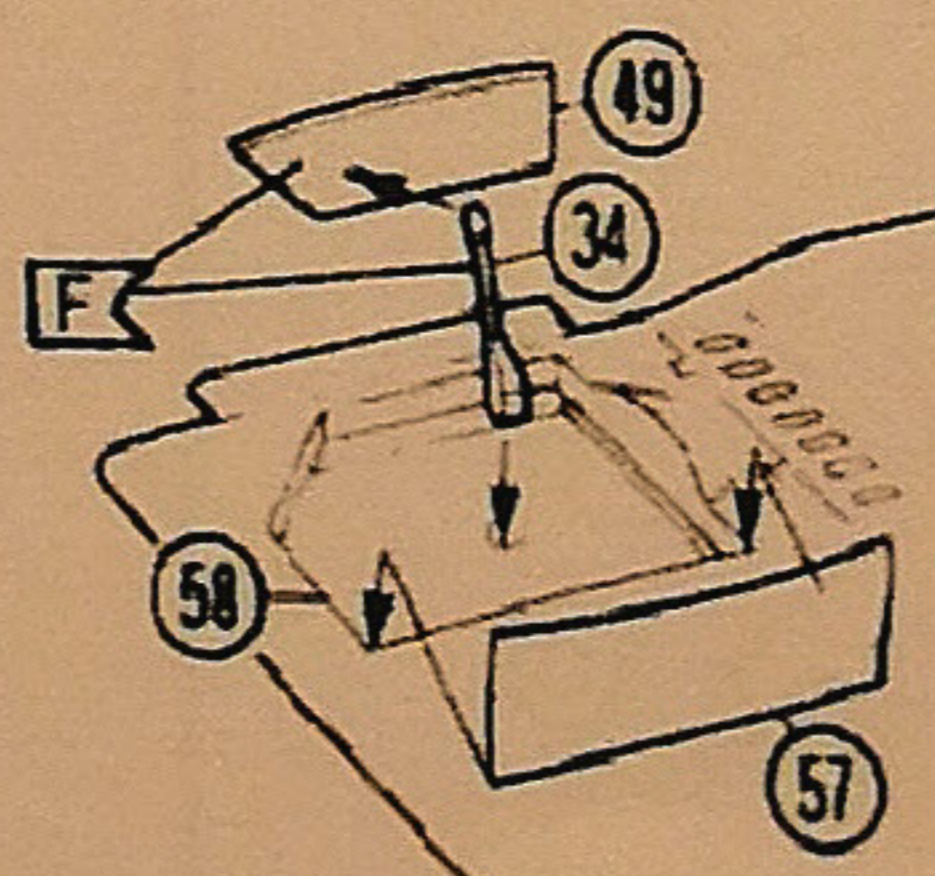

XTRACOLOR / XTRACRYLIX References

23

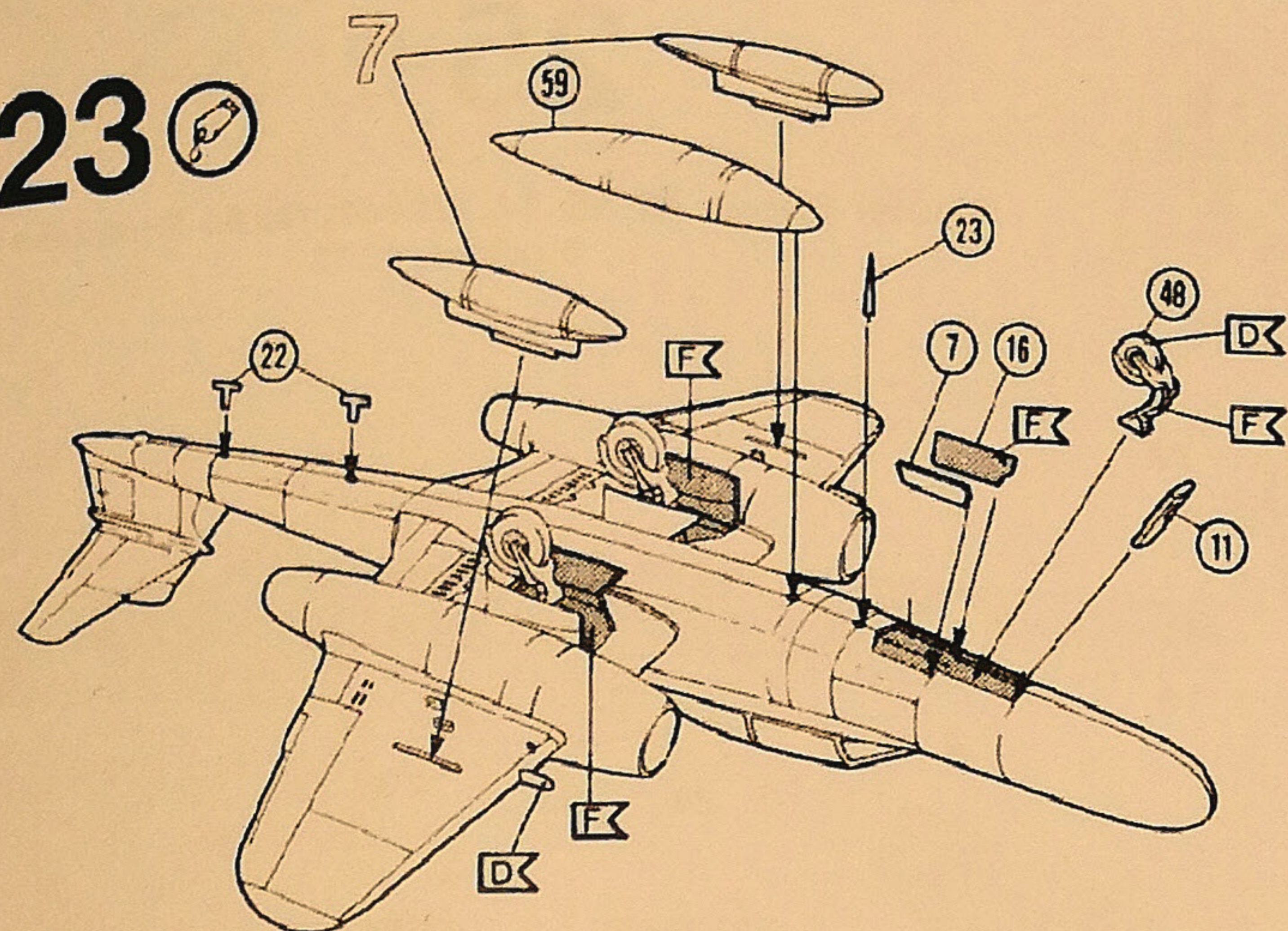

- A** RAF Dark Green - X001/XA1001
- B** RAF Medium Sea Grey - X003/XA1003
- C** RAF Dark Sea Grey - X004/XA1004
- F** High Speed Silver - X038
- T** Tyre Black - X505
- D** Black - XA1012
- S** Silver - XA1216

24

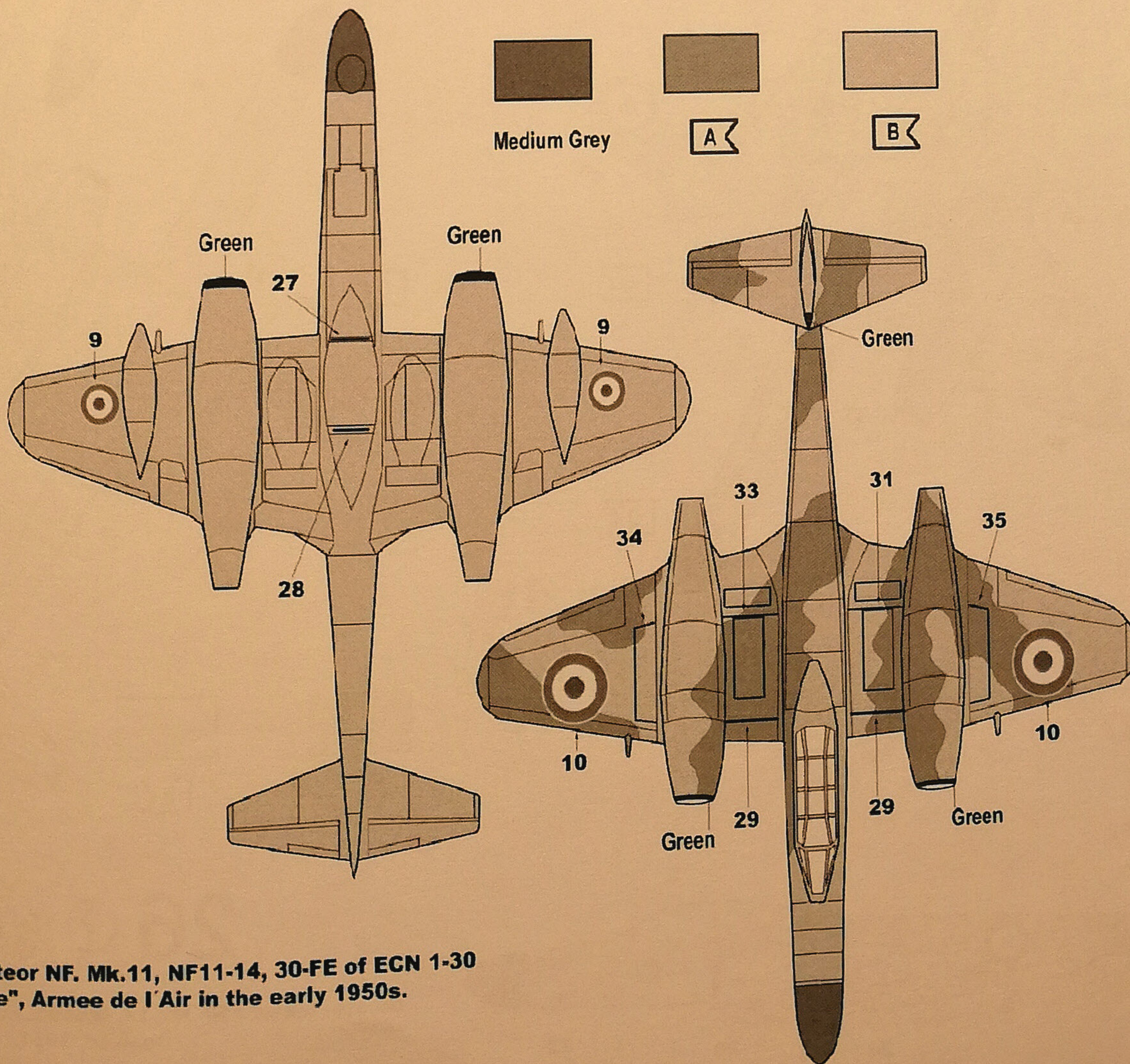
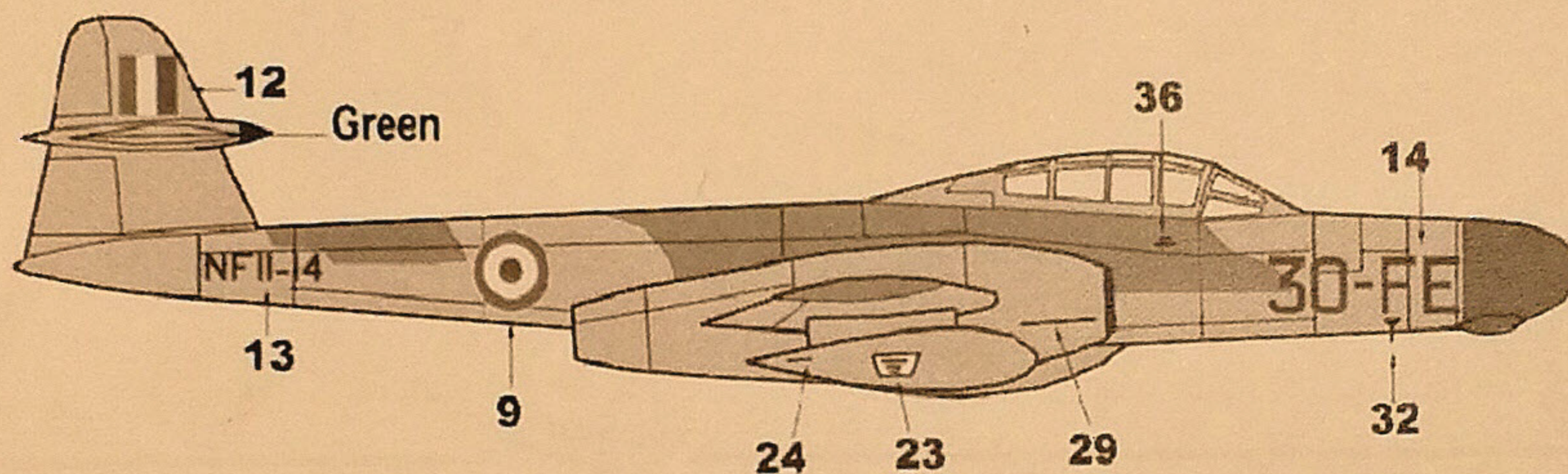
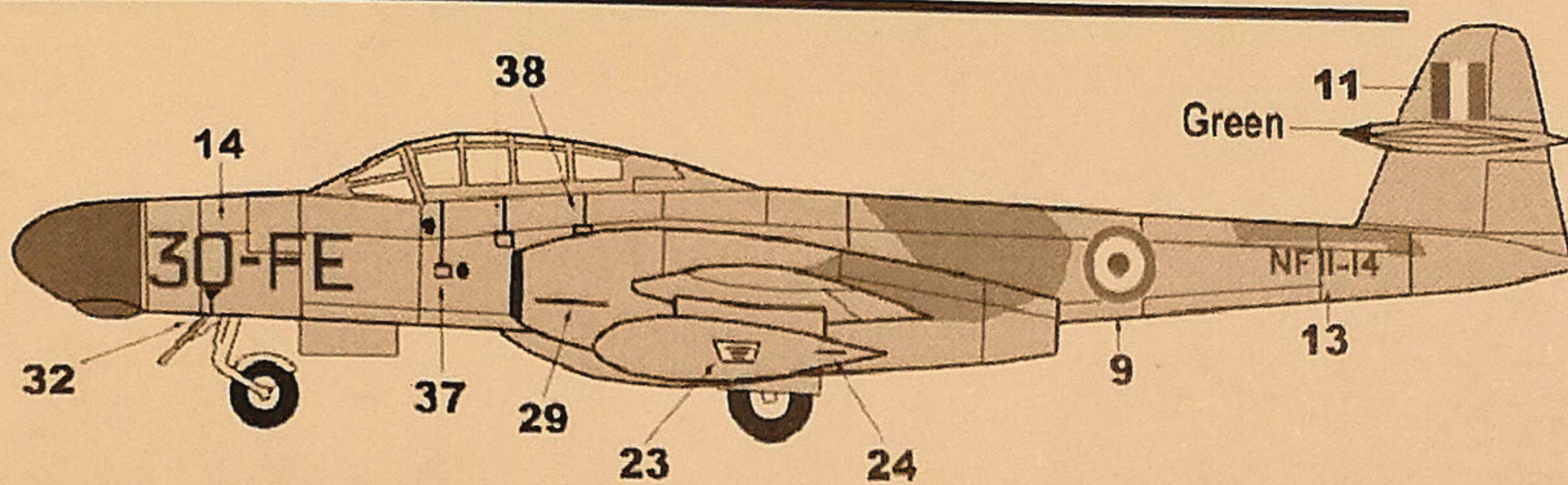

Gloster Meteor NF. Mk.11, NF11-14, 30-FE of ECN 1-30 "Loire", Armee de l'Air in the early 1950s.



Gloster Meteor NF Mk.14, WS840, No 64 Squadron RAF, Duxford, 1958.

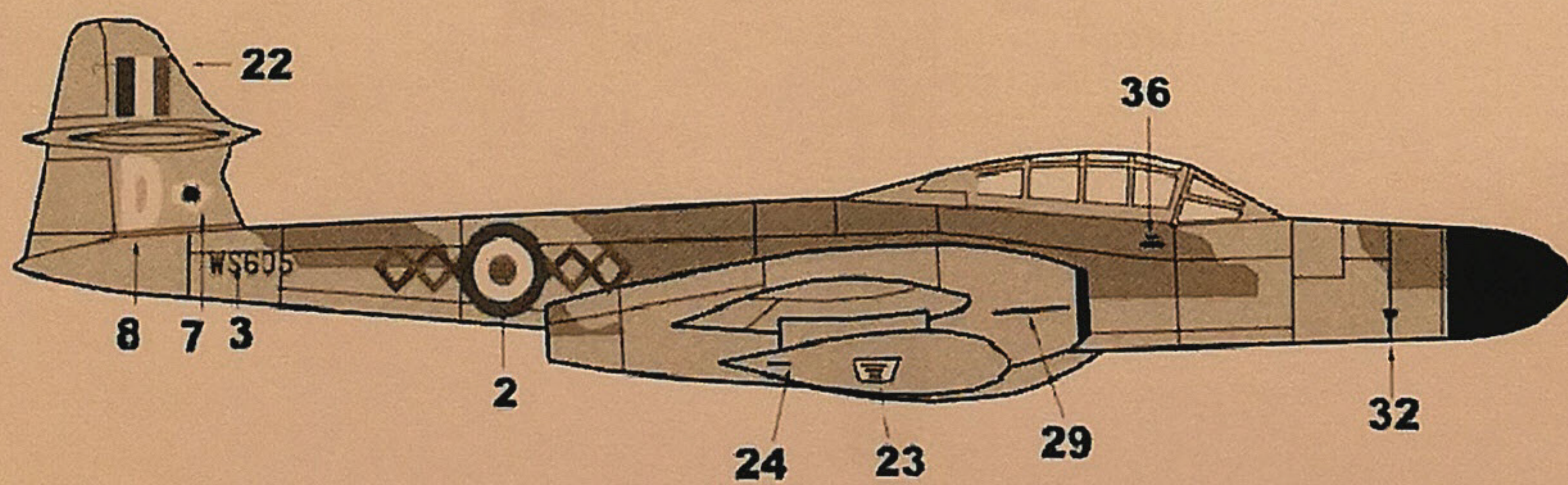
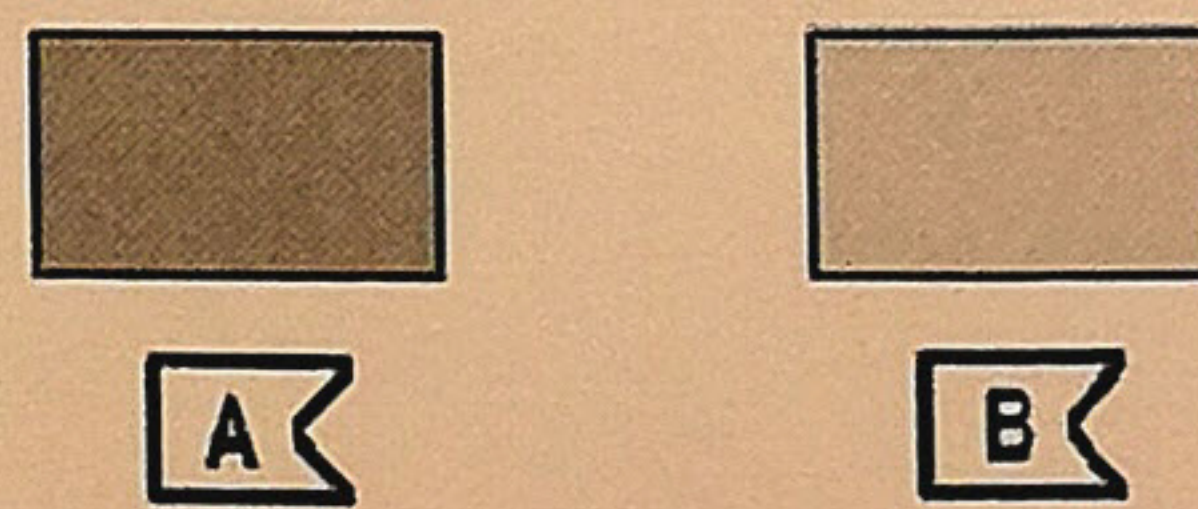
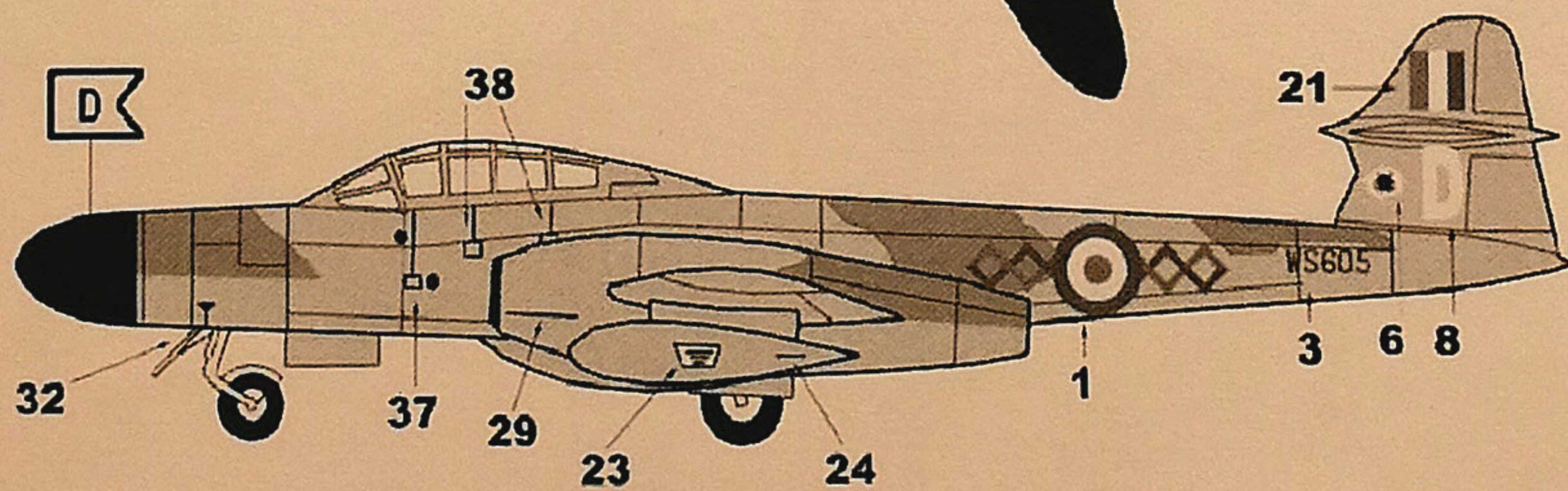
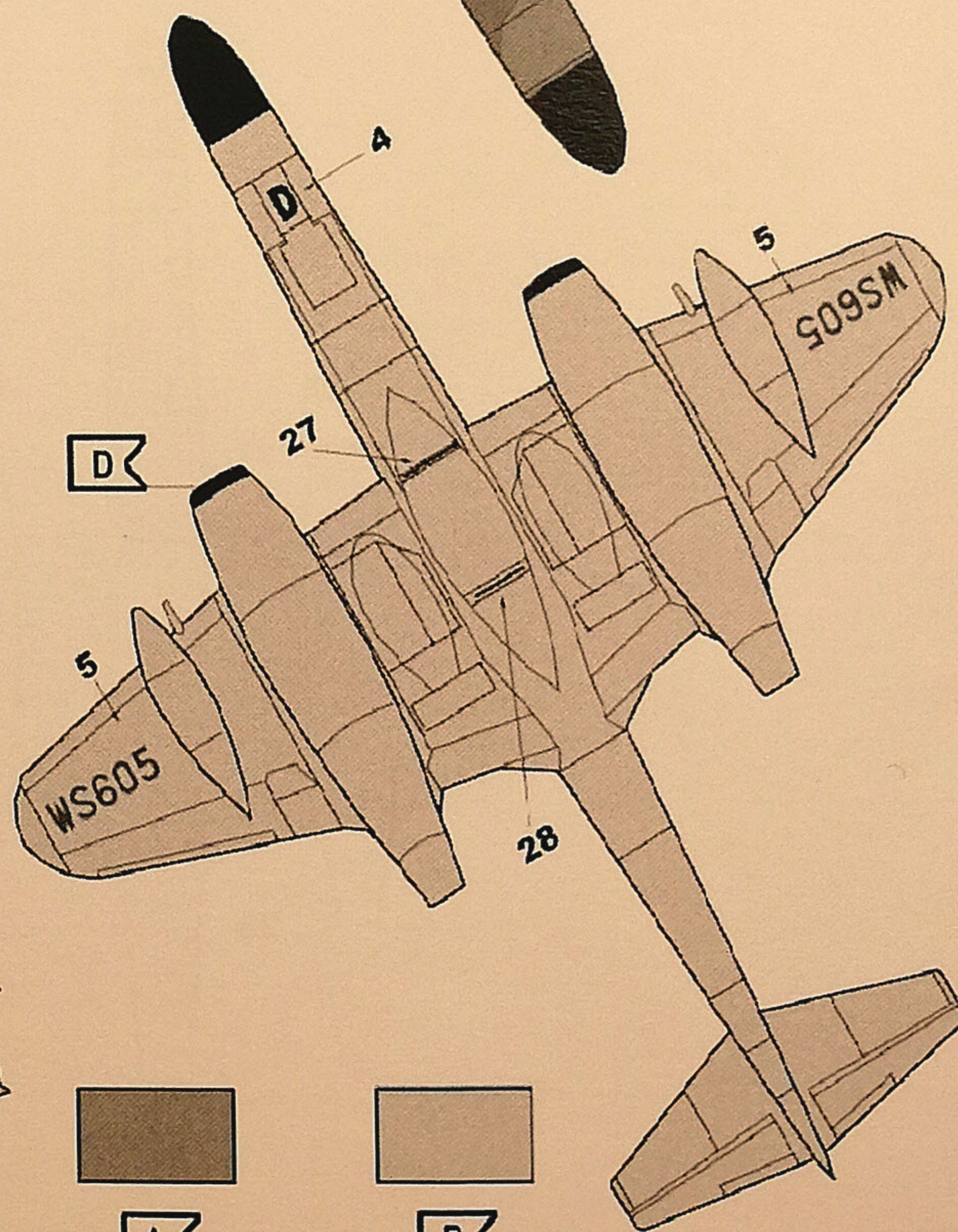
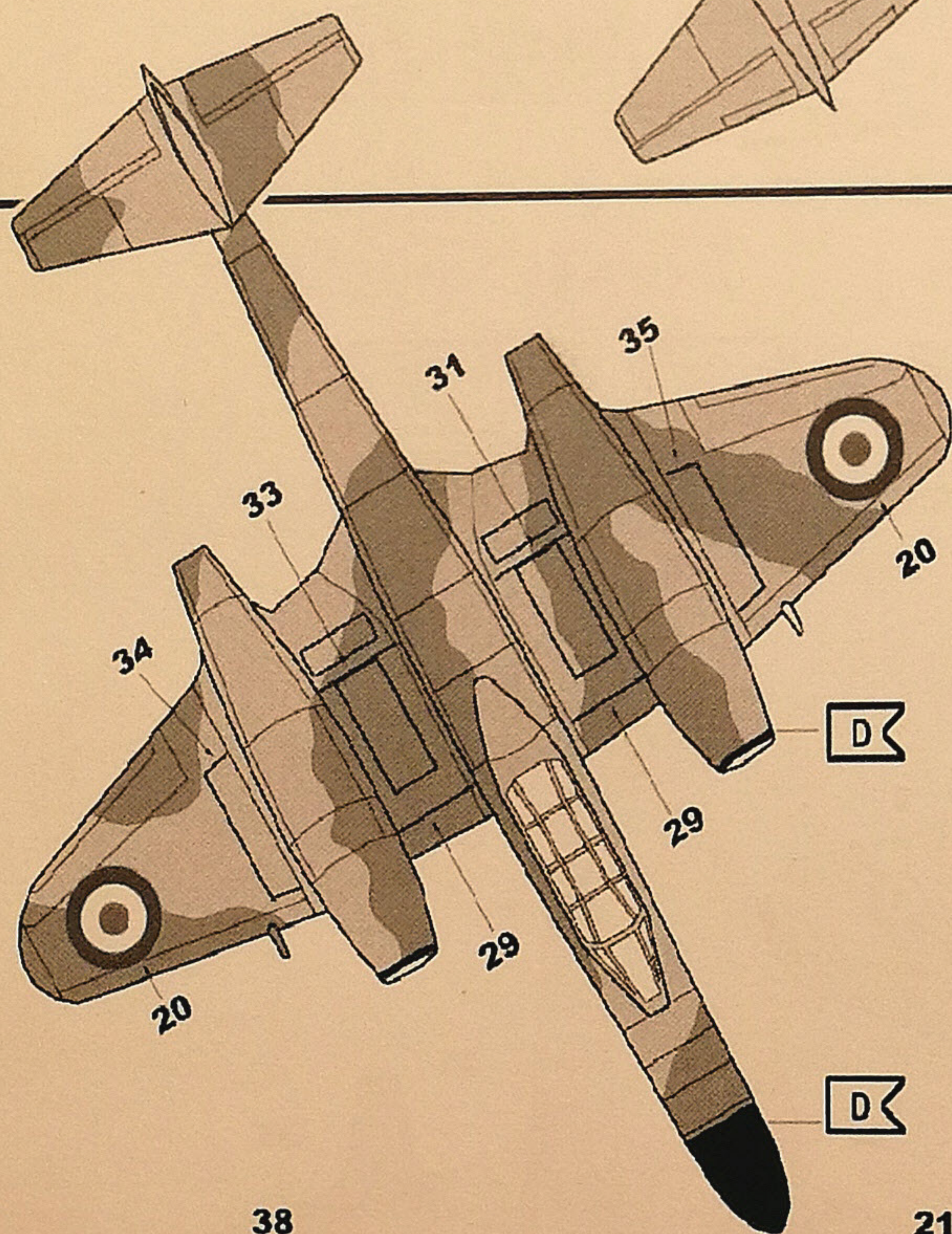
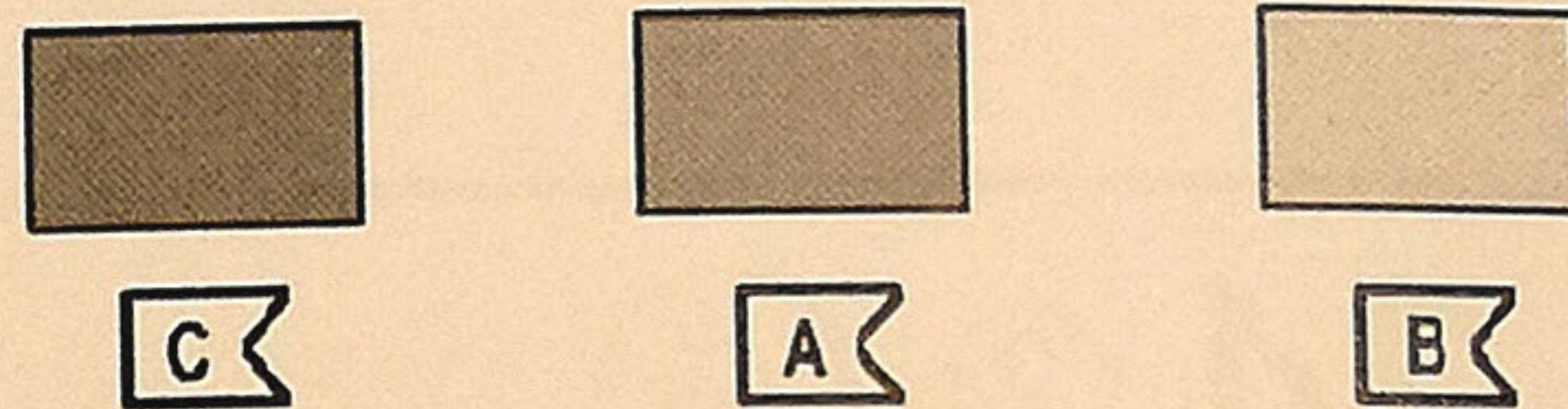
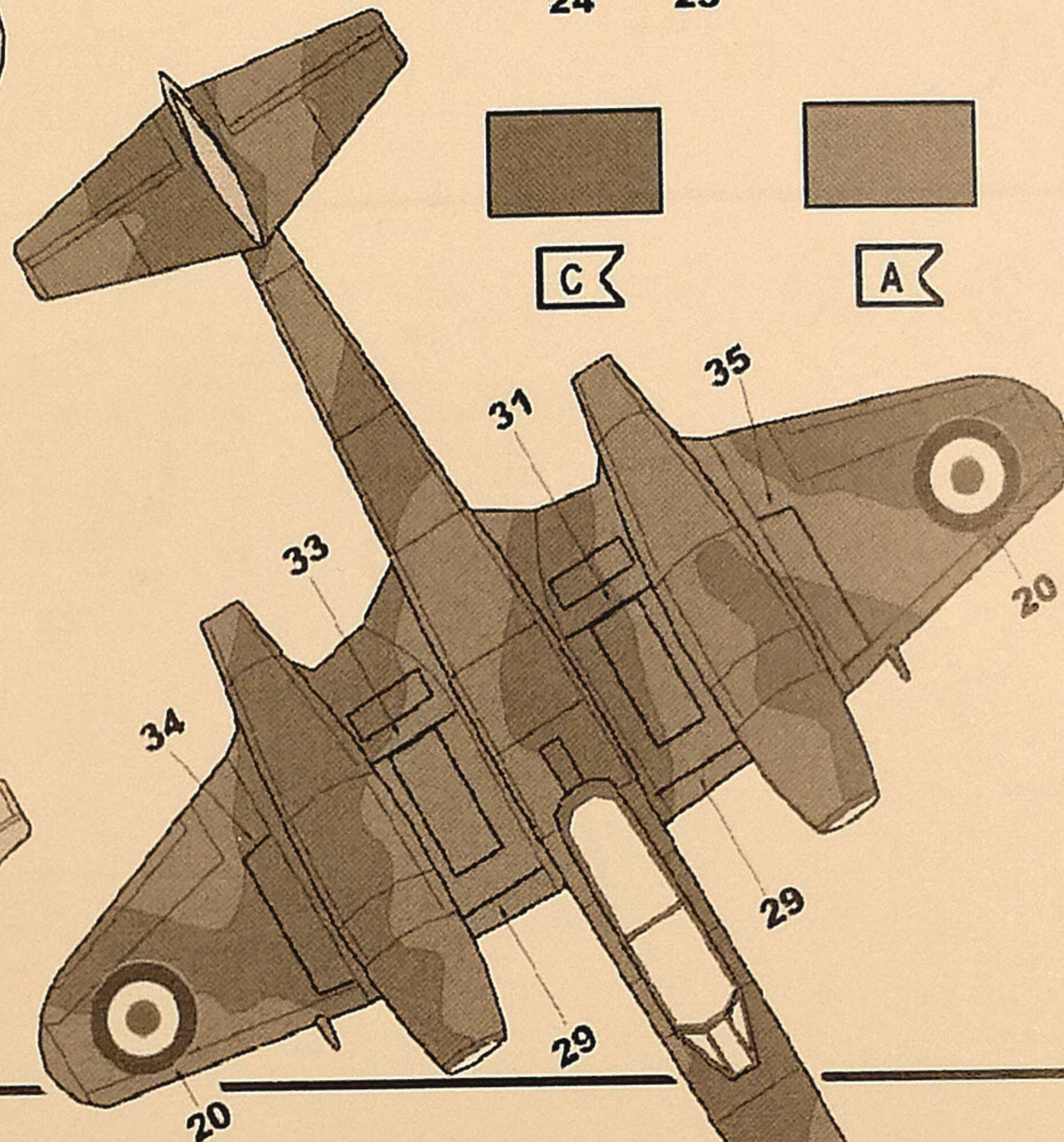
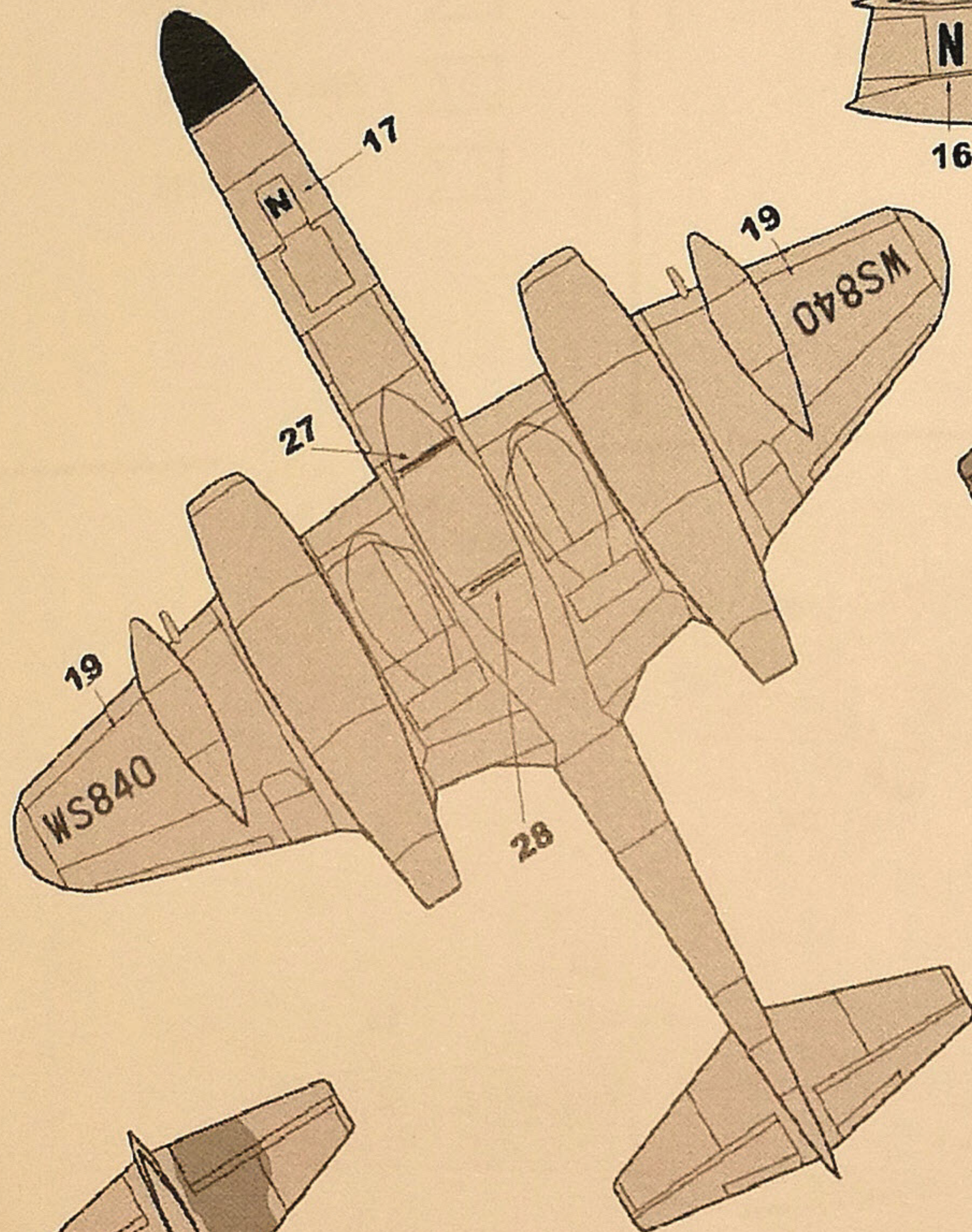
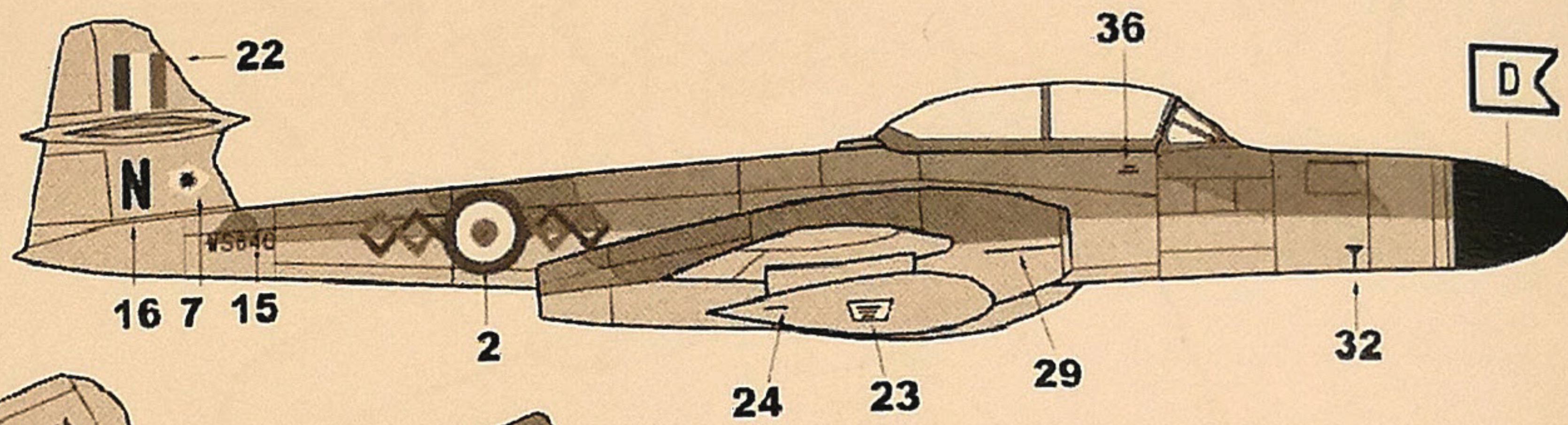
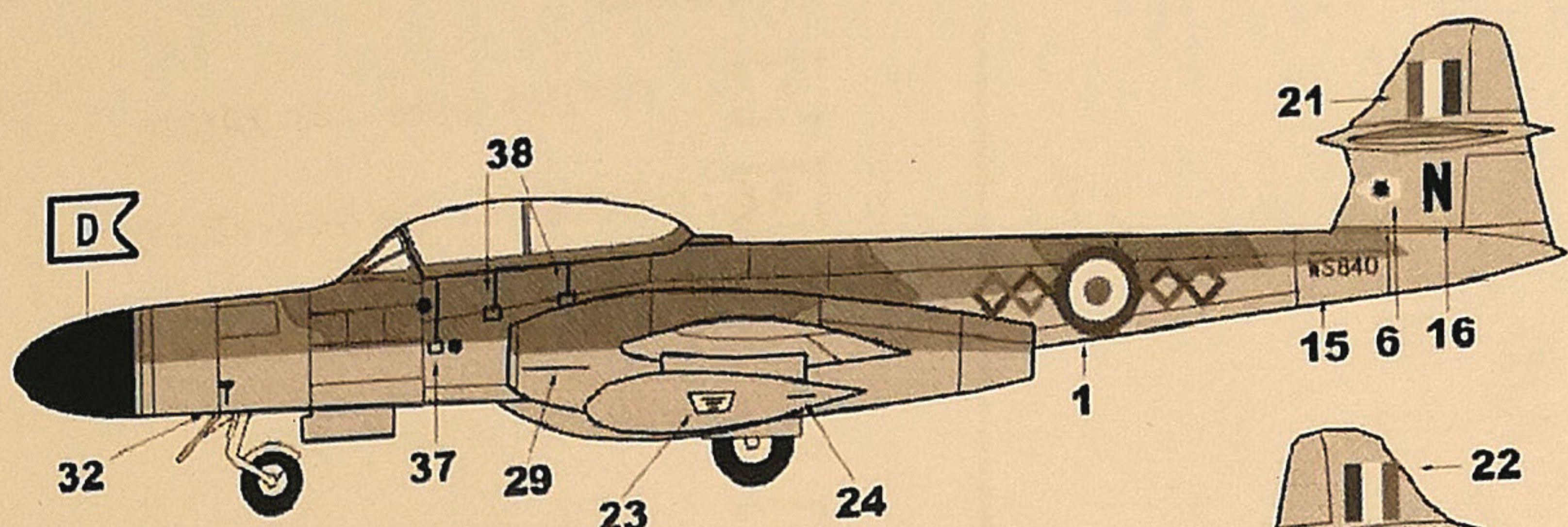

Gloster Meteor NF Mk.12, WS605, No 64 Squadron RAF, Duxford, 1957.