

CZECHOSLOVAK BIPLANE FIGHTER 1:48 SCALE PLASTIC KIT



intro

The Avia B-534 was developed in 1934 as an extension of the B-34 fighter. In this incarnation, which was produced in small numbers for the Czechoslovak Air Force (the majority of which were attached to No.3 Fighter Squadron in Slovakia at the beginning of the Second World War), there were several engine/airframe combinations tried. The B-234 prototype served as the basis for the re-engined (Hispano Suiza 12 Ydrs for the original Avia R-29 radial) type that became the true B-534. This was the 1934 victor in a tender for a new standard fighter for the air force, and in June of that year, Avia received an order for an initial 34 aircraft. The orders accumulated to a total of 568 units, built in several production blocks.

Assessments of the aircraft are somewhat variable. At the time of its development, it was an aircraft that was technically sound and utilized progressive construction techniques, but by the time of the Munich Crisis, the technology was slowly but surely entering the realm of the obsolete. To top it off, the politics of the situation during the Crisis disallowed the chance of combat. The chance for combat missions to be flown didn't occur until a few years later, in 1941, in the services of the Slovak State, fighting for the side that had previously been the aggressor against which they were to stand. Slovak pilots flying the B-534 on the Eastern Front gained good results, and these can be viewed upon as being the climax of the career of the type. A year later, it was apparent that replacement by more modern types was necessary, and inevitable. Bulgarian attempts to combat Ploesti raiding B-24 Liberators with the B-534 was a failure, and the aging planes were not able to climb to the Liberator's operational altitudes. In Slovakia, as in Bulgaria, the type was destined for second line relegation.

Some of the remaining B-534s were destined for final operations within the Bulgarian Air Force in operations over Hungary in 1944, and with Slovakia during the several weeks long uprising against Germany (late August early November 1944). During the Slovak National Uprising, the type was used primarily in the ground attack role, and one did manage a kill to become what is the last aerial victory of a biplane in history. It should be noted that the kill in question was that of a Hungarian transport. The fact remains that the Slovak National Uprising did end up being the swansong of the Avia B-534. Certainly, it can be said that due to the era and climate of the service of this aircraft, and the length of service it was able to achieve, the Avia B-534 has become one of the most profound symbols of Czechoslovak aviation history, a very positive symbol.

intro

Avia B-534 vznikla v roce 1934 vývojem základního typu B-34. Z této konstrukce, která byla vyrobena v malé sérii pro československé letectvo (většina vyrobených strojů sloužila u Leteckého pluku 3 na Slovensku a později doletěla ve službách Slovenského státu na začátku 2.světové války), bylo odvozeno několik motorových variant. Z prototypu B-234 vznikla záměnou motoru (Hispano Suiza 12 Ydrs za původní hvězdicový Avia R-29) právě B-534. Ta zvítězila v roce 1934 v tendru vojenského letectva na novou standardní stíhačku, a v červenci 1934 dostala Avia první objednávku na 34 kusů. Objednávky byly postupně rozšiřovány až na konečných 568 kusů, vyrobených v několika výrobních blocích.

Hodnocení výkonů Avie B-534 je poněkud rozporné. Ač to byl stroj v době svého vzniku technicky jistě na výši doby a využíval progresivní konstrukční prvky, v době Mnichovské krize už pomalu, ale jistě zastarával. Vzhledem k politickým okolnostem navíc piloti nedostali příležitost zasáhnout do boje, k jehož vedení byli cvičeni a motivováni. Do skutečného boje se Avie dostaly až o několik let později, v roce 1941, ve službách Slovenských Vzdušných zbraní, tedy de facto na straně původního protivníka. Na Východní frontě předvedli slovenští piloti v kabinách Avii dobré výkony, díky nimž lze nasazení na východě považovat za vrchol kariéry Avie B-534. O rok později už ale Avii zvonila hrana, a přišel čas jejich náhrady modernějšími stroji. Pokus Bulharů z roku 1943 o zásah proti americkým Liberatorům, útočícím na Ploesti, skočil jednoznačným neúspěchem. Avie nedokázaly ani vystoupat do operační výšky Liberatorů. Jak na Slovensku, tak v Bulharsku čekal Avie osud většiny vysloužilých stíhaček, přešly nejprve k bitevním úkolům a poté k pomocným rolím. Na několik zbylých Avii čekal poslední boj, v rámci bulharského letectva při plnění bitevních úkolů v Maďarsku, na slovenské Avie pak několikátýdenní vystoupení při protiněmeckém povstání na Slovensku. I zde převážně útočily na pozemní cíle, nicméně jedna z Avii zaznamenala poslední sestřel dosažený tímto typem, a pravděpodobně vůbec poslední sestřel dosažený dvouplošníkem v dějinách. Je ovšem nutné dodat, že šlo o sestřel neozbrojeného dopravního letounu, což je záležitost, vzhledem ke všem okolnostem této události, poněkud diskutabilní. Službou v SNP se fakticky historie Avie B-534 uzavírá. Přes zmíněnou nepřízeň osudu se Avie B-534, díky délce své služby i historickému období, kdy ve službě byla, stala jedním ze symbolů československého letectva. A to symbolem jednoznačně pozitivním.

ATTENTION

* UPOZORNĚNÍ

* ACHTUNG

* ATTENTION

* 注意



Carefully read instruction sheet before assembling. When you use glue or paint, do not use near open flame and use in well ventilated room. Keep out of reach of small children. Children must not be allowed to suck any part, or pull vinyl bag over the head.



Před započítím stavby si pečlivě prostudujte stavební návod. Při používání barev a lepidel pracujte v dobře větrané místnosti. Lepidla ani barvy nepoužívejte v blízkosti otevřeného ohně. Model není určen malým dětem, mohlo by dojít k požití drobných dílů.

INSTRUCTION SIGNS * INSTR. SYMBOLS * INSTRUKTION SINNBILDEN * SYMBOLES * 記号の説明

OPTIONAL
VOLBABEND
OHNOUTOPEN HOLE
VYVRTAT OTVORSYMMETRICAL ASSEMBLY
SYMETRICKÁ MONTÁŽNOTCH
ZÁŘEZREMOVE
ODRÁZNOUTAPPLY EDUARD MASK AND PAINT
POUŽIT EDUARDS MASK NABARVIT

PARTS

* DÍLY

* TEILE

* PIÈCES

* 部品

PLASTIC PARTS

A>

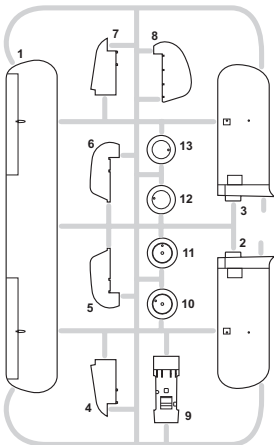

B>

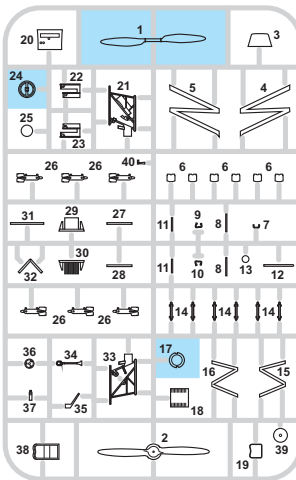

C>

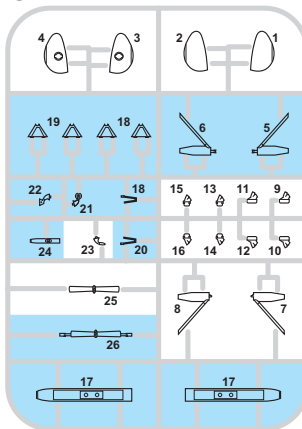

D>

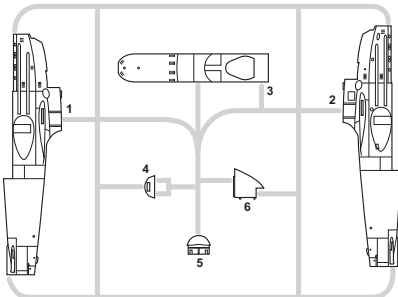
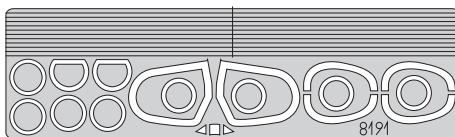
eduard
MASK

F>

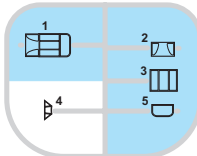
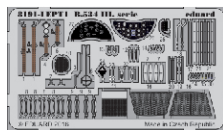
PE - PHOTO ETCHED
DETAIL PARTS

-Parts not for use. -Teile werden nicht verwendet. -Pièces à ne pas utiliser. -Tyto díly nepoužívejte při stavbě. - 使用しない部品

COLOURS

* BARVY

* FARBEN

* PEINTURE

* 色

GSI Creos (GUNZE)		
AQUEOUS	Mr. COLOR	
[H 3]	[3]	RED
[H 6]	[6]	GREEN
[H 7]	[7]	BROWN
[H 8]	[8]	SILVER
[H 11]	[62]	FLAT WHITE
[H 12]	[33]	FLAT BLACK
[H 28]	[78]	METAL BLACK
[H 37]	[43]	WOOD BROWN
[H 47]	[41]	RED BROWN

AQUEOUS	Mr. COLOR	
[H 51]	[11]	LIGHT GRAY
[H 64]	[17]	BLACK GREEN
[H 77]	[137]	TIRE BLACK
[H 81]	[55]	KHAKI
Mr. COLOR GX		
[GX5]		BLUE
Mr. METAL COLOR		
[MC214]		DARK IRON
[MC219]		COPPER

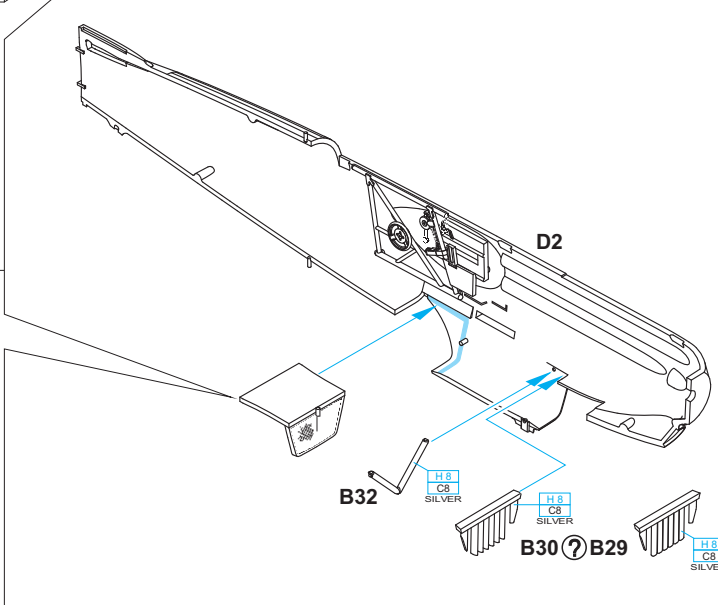
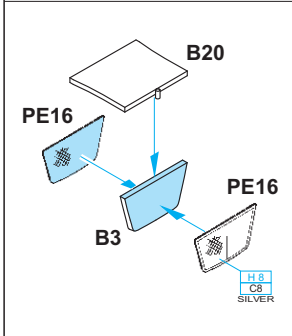
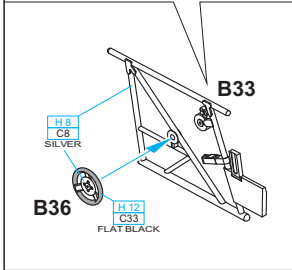
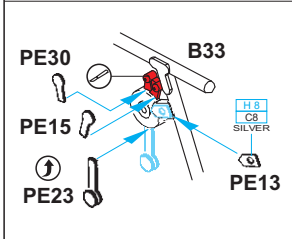
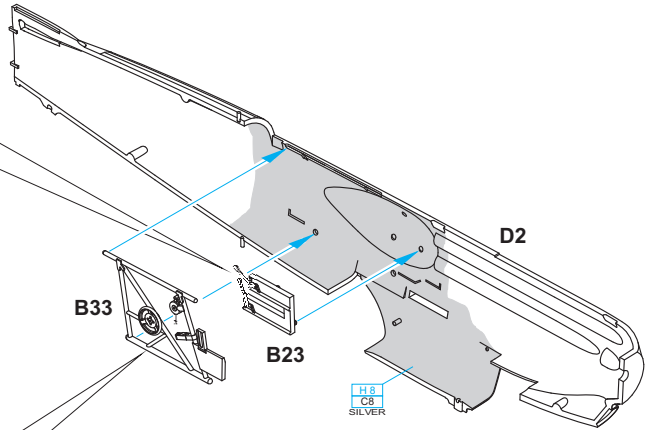
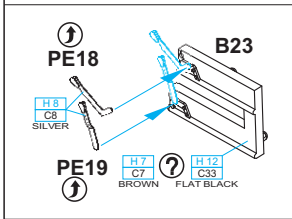
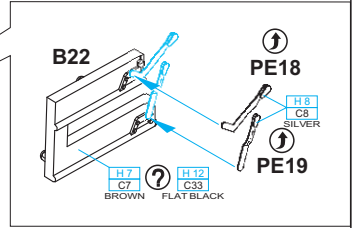
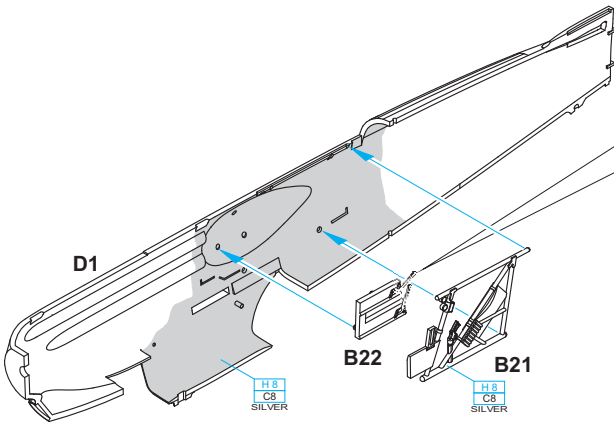

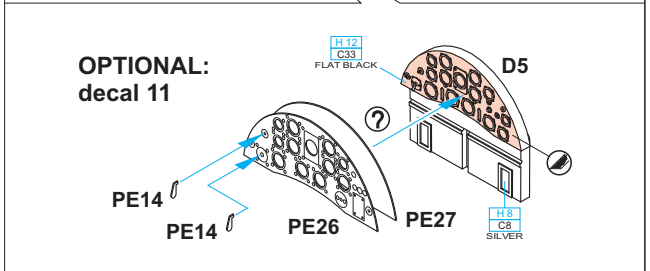
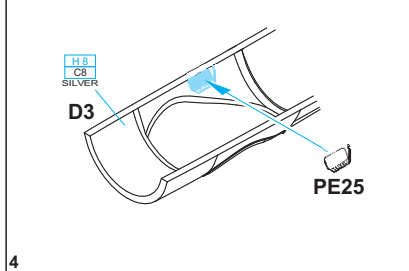
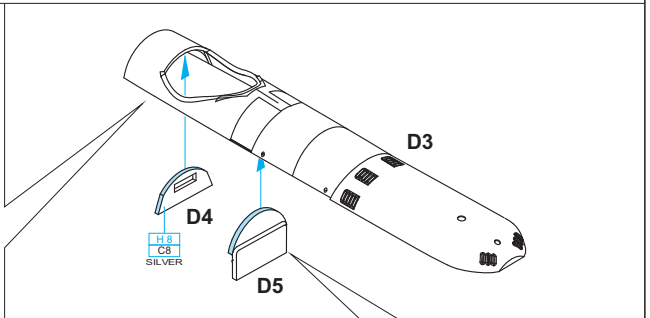
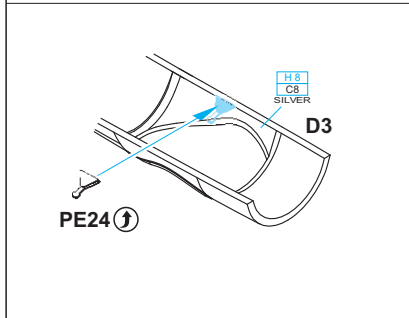
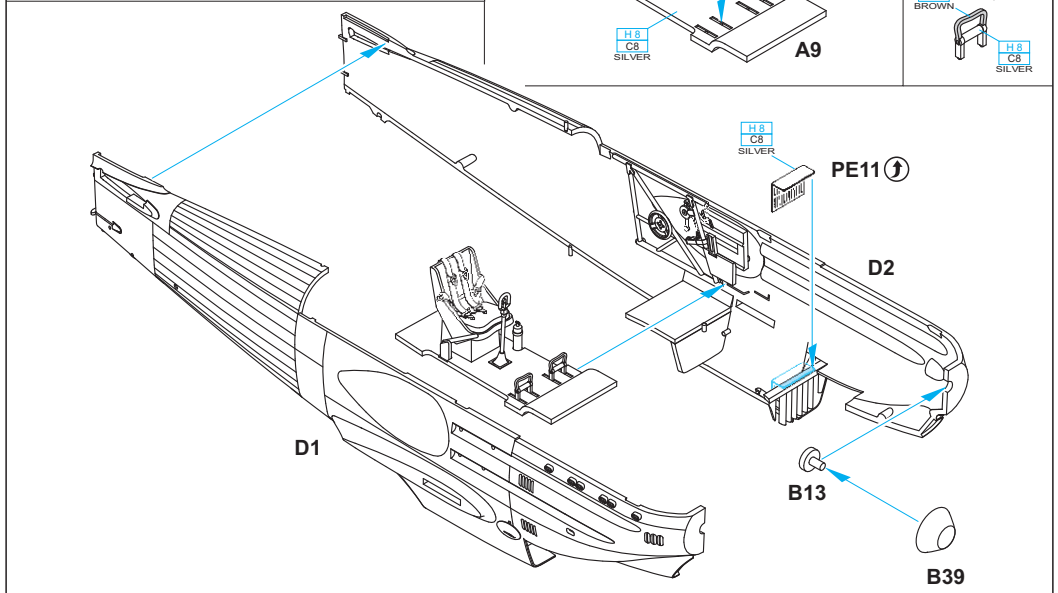
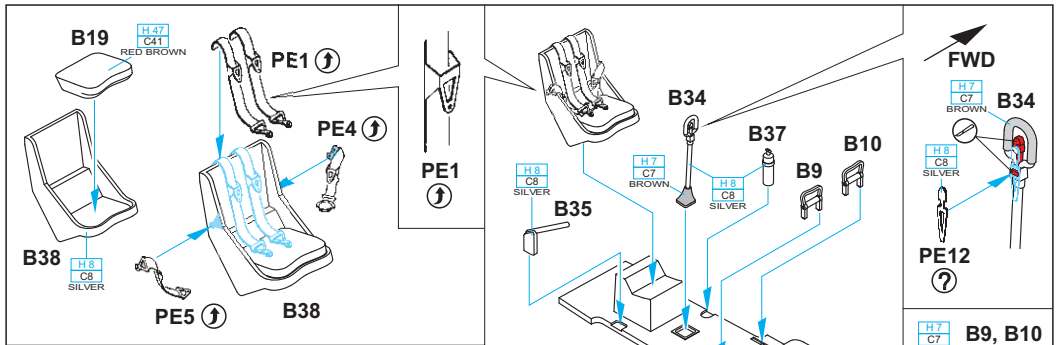

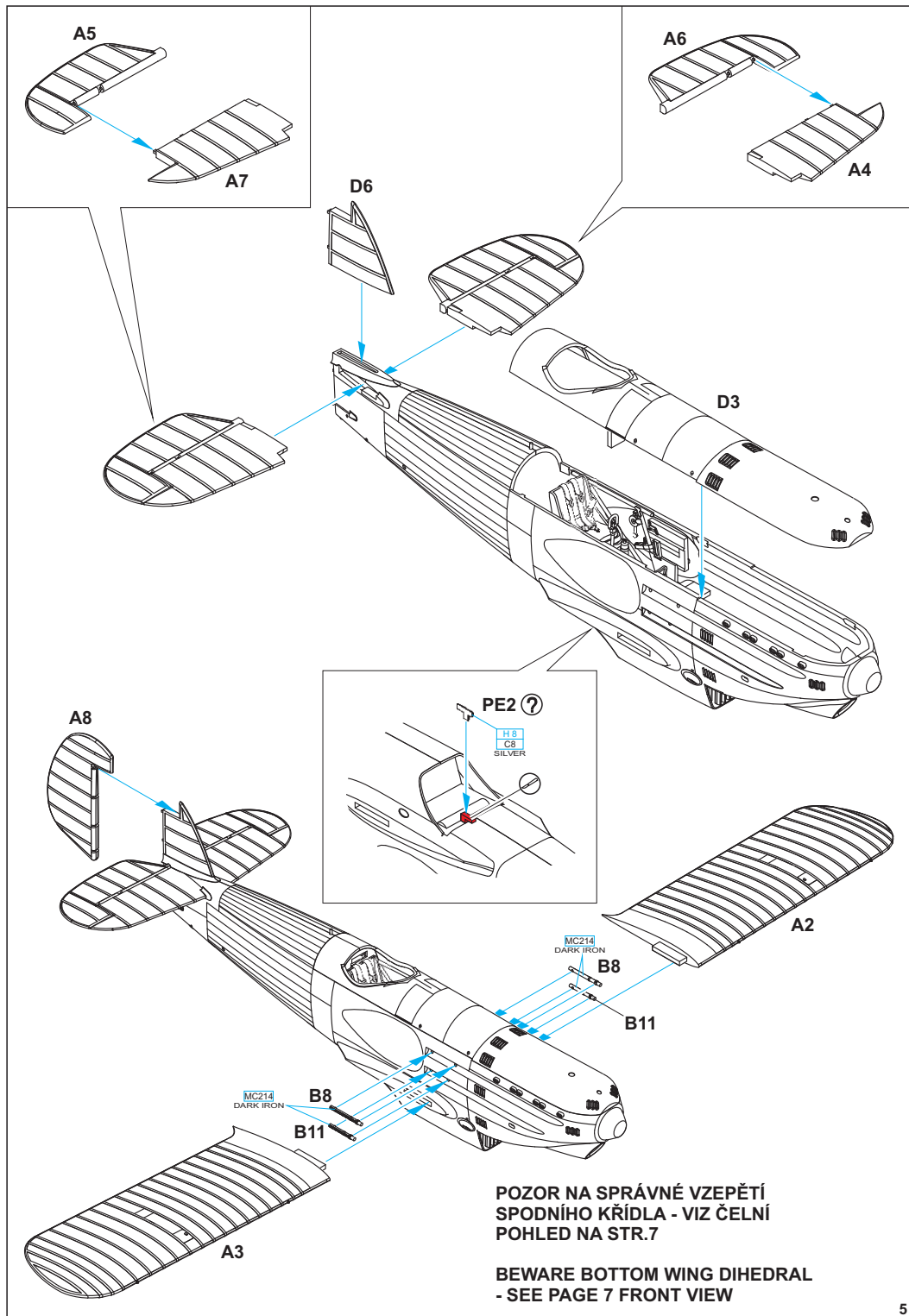

**POZOR NA SPRÁVNÉ VZEPĚTÍ
SPODNÍHO KŘÍDLA - VIZ ČELNÍ
POHLED NA STR.7**

**BEWARE BOTTOM WING DIHEDRAL
- SEE PAGE 7 FRONT VIEW**

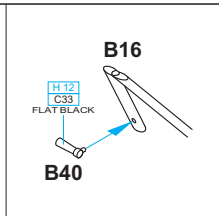
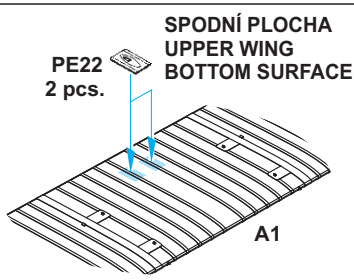

POZOR NA SPRÁVNOU ORIENTACI A POZICI
VZPÉR!
BEWARE CORRECT STRUT POSITION!

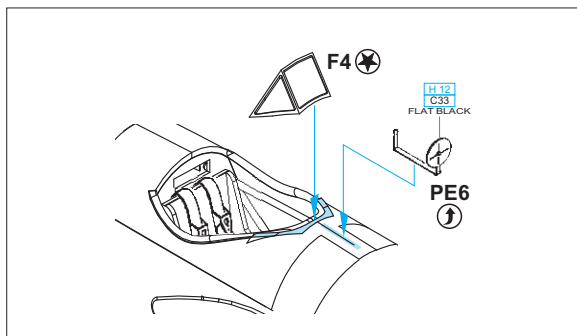
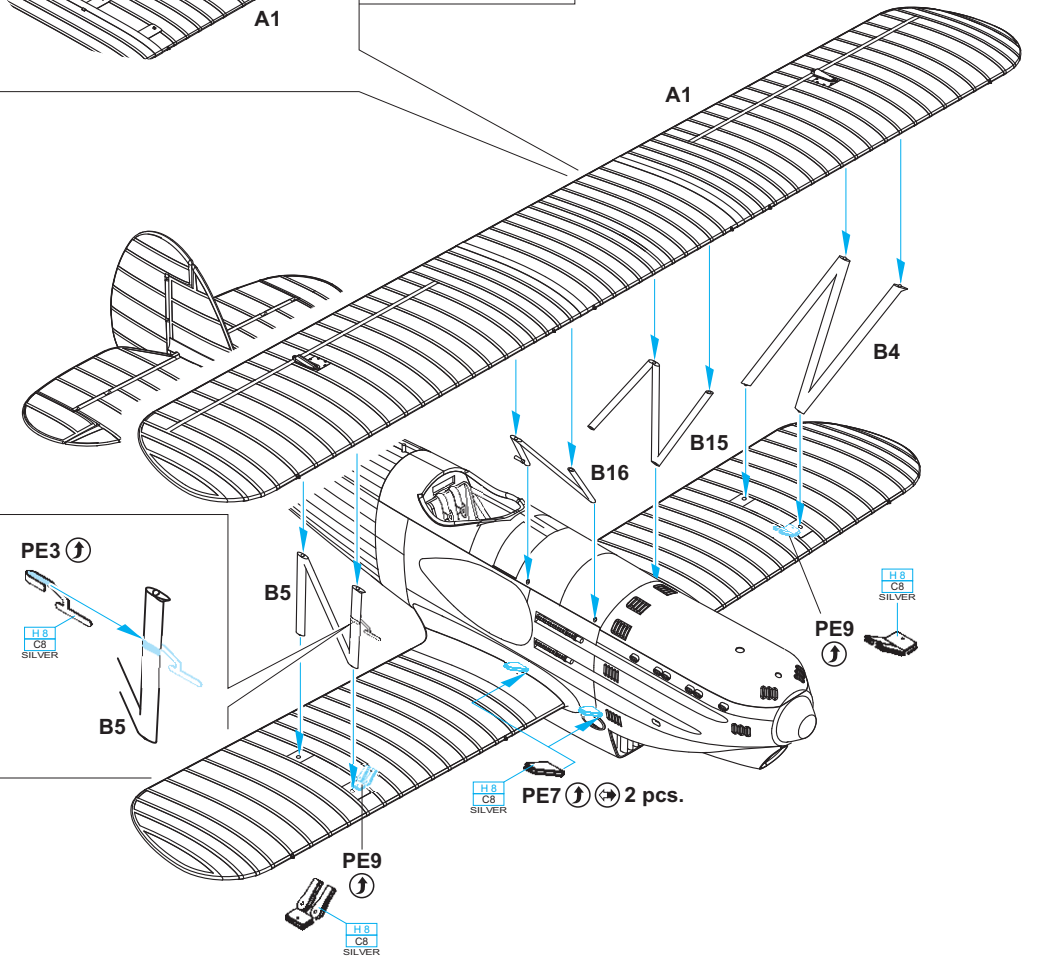

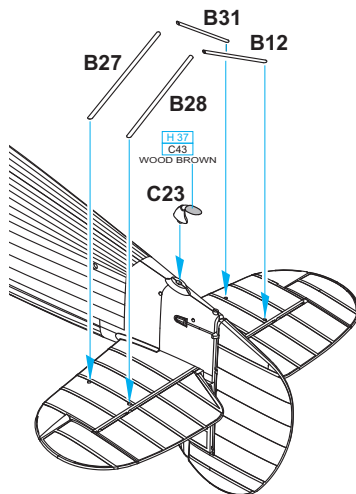
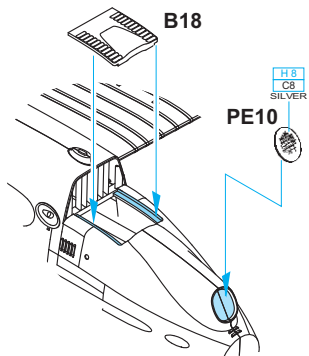
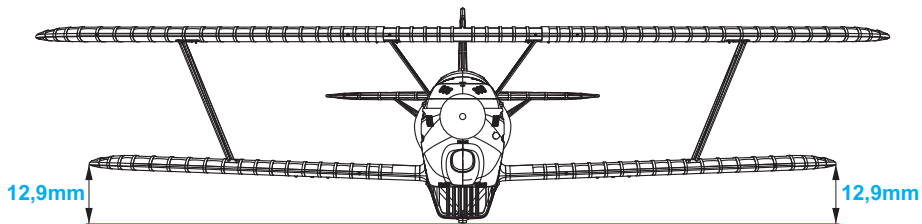

L

R

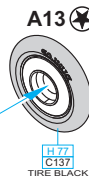
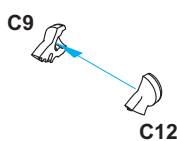
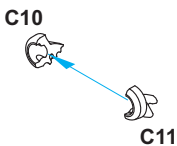
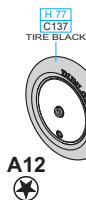

?

?

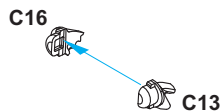
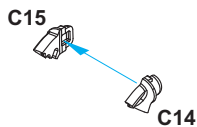
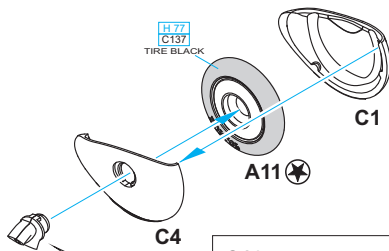
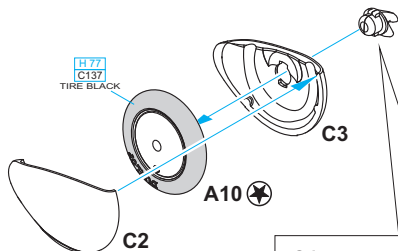

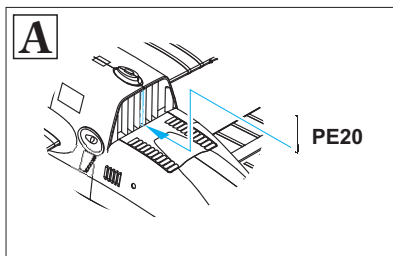
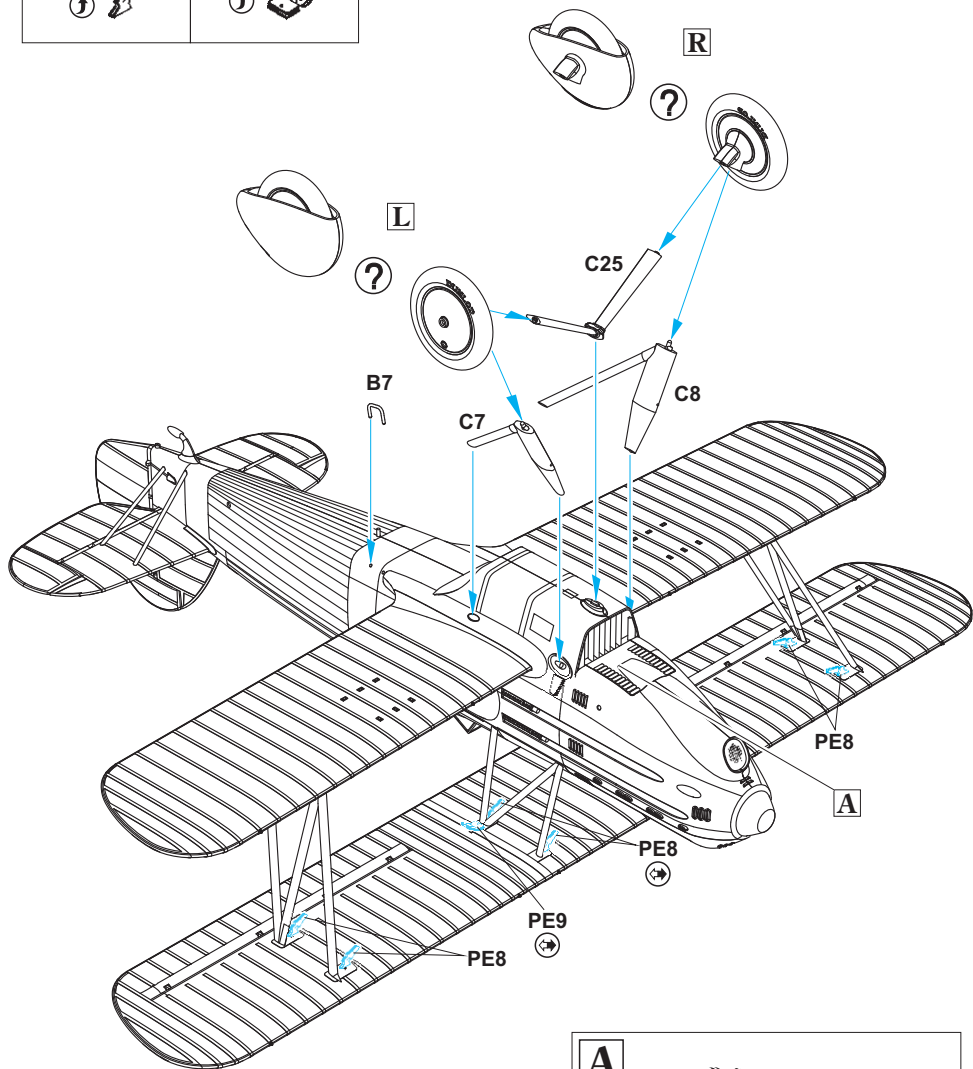
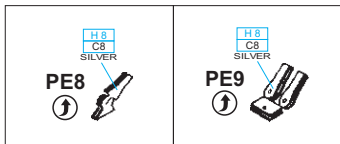

6 pcs.

B26

B6

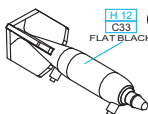

H 12 ? H 64
C33 C17
FLAT BLACK - BLACK GREEN

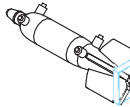

B14



H 8
C8
SILVER

PE21 ⬆

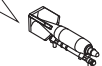

3 pcs.

3 pcs.

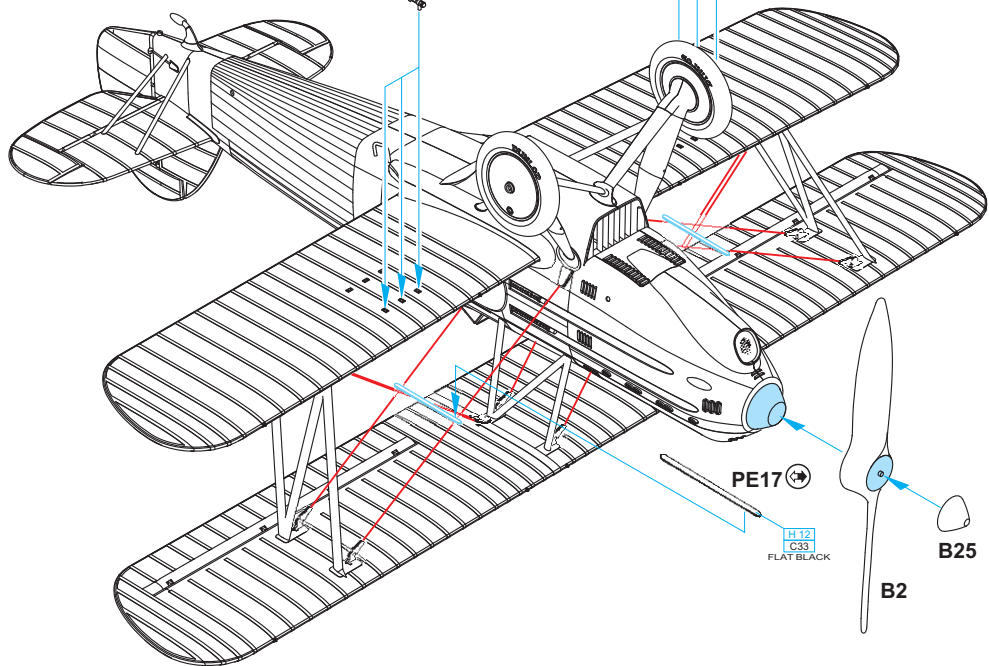

PE17 ⬆

H 12
C33
FLAT BLACK

B25

B2

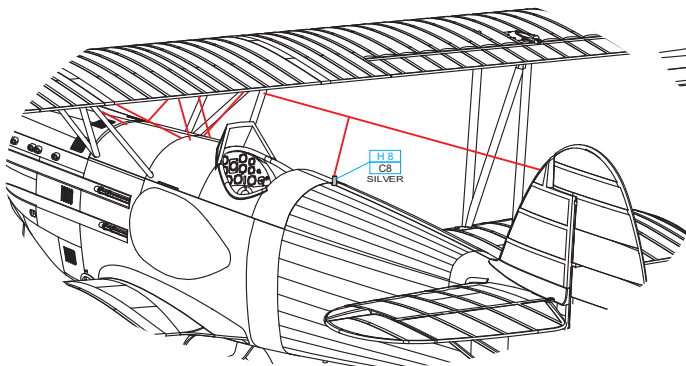

H 8
C8
SILVER

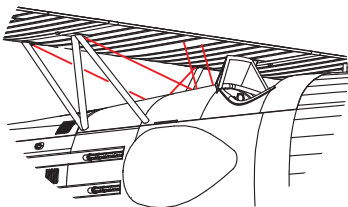

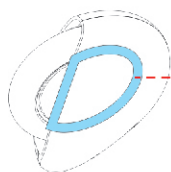

203

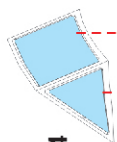

F4

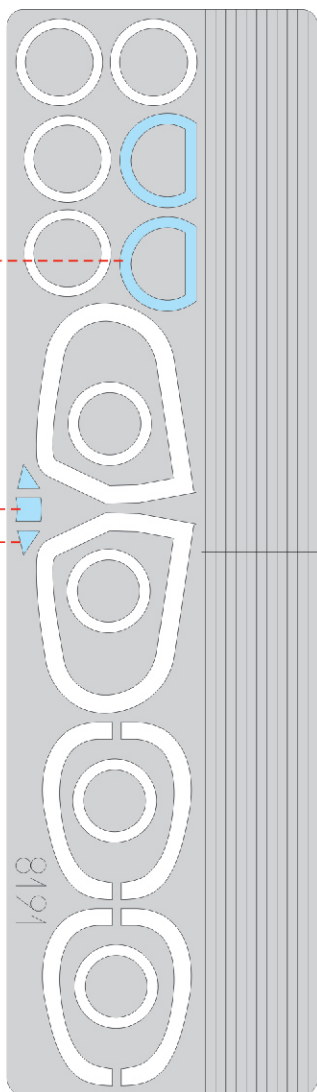

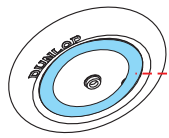

A10, A11

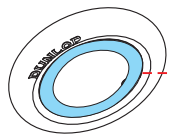

A12, A13

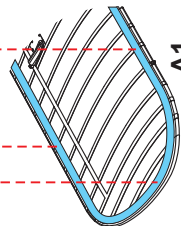
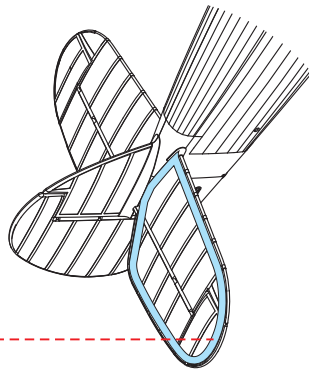
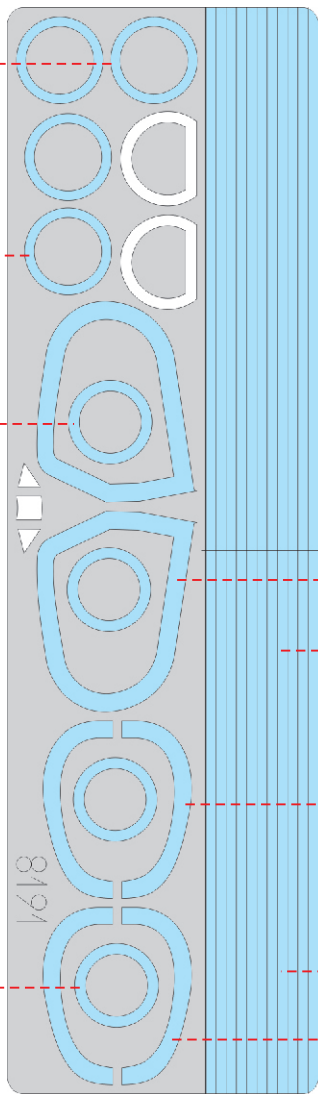

A1

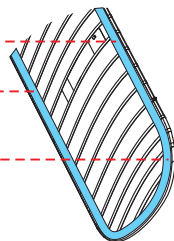

A3

A2

B No.2 Air Regiment, 51st Squadron, Olomouc, Czechoslovakia, May 1937 - March 1939

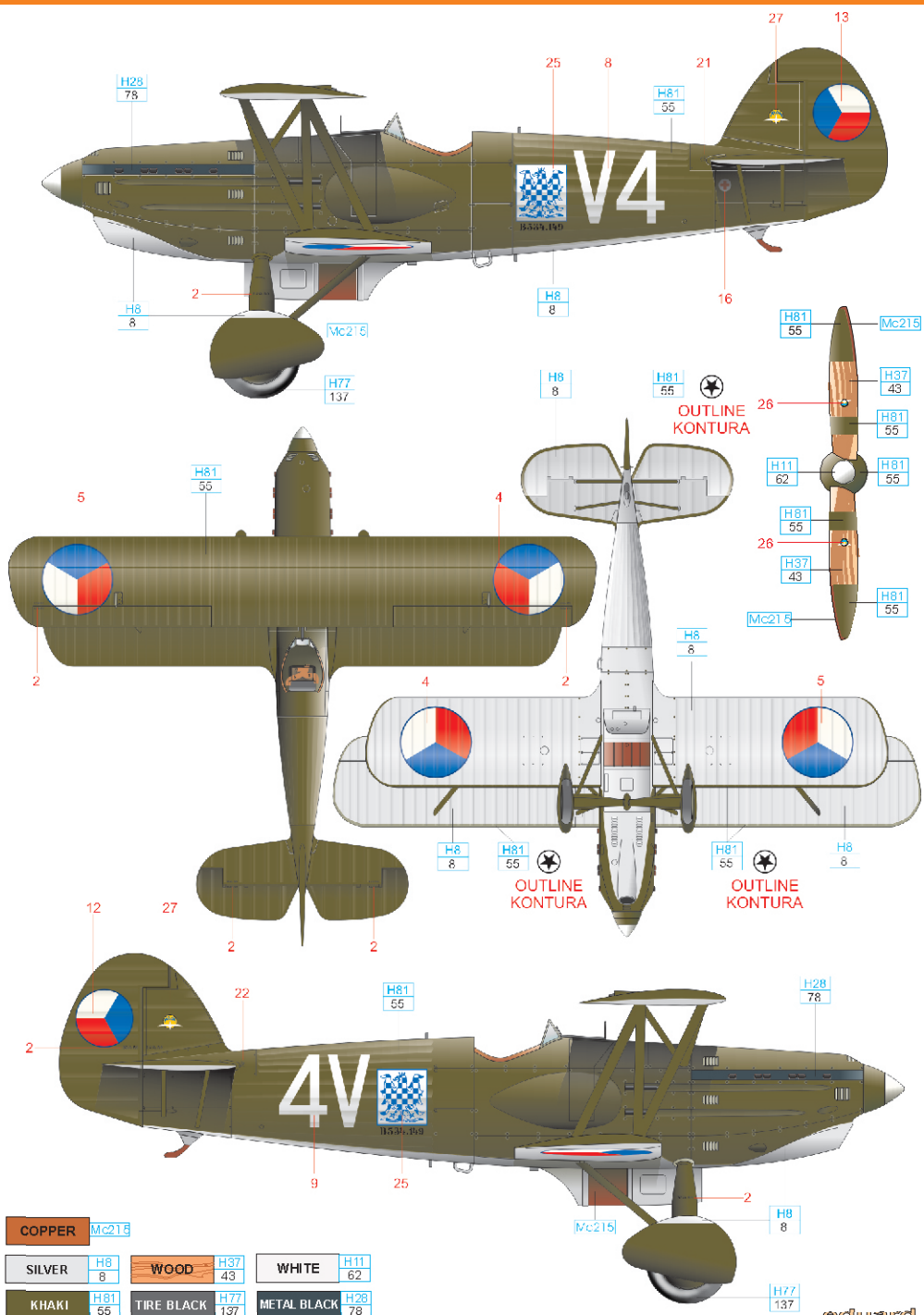

D 11th Squadron, Slovak Air Force, Piestany, winter, 1939/1940

