

A

P-38G, serial unknown. Flown by 2. Versuchsverband der Ob.d.L., or Zirkus Rosarius (Rosarius' Flying Circus), after the unit's commander, Hauptmann Theodor Rosarius. Flown to various Luftwaffe fighter bases from late 1943 for DACM - Dissimilar Air Combat Maneuvering training. One of two Lightnings reportedly used on clandestine reconnaissance missions. Upper surfaces painted RLM 70 Schwarzgrün with RLM 04 Gelb tail unit and undersurfaces. Non-standard Balkenkreuze. Swastikas carried on both sides of each fin/rudder assembly. Codes read T9 XB on both booms. **Codes read T9 XB on both booms.**

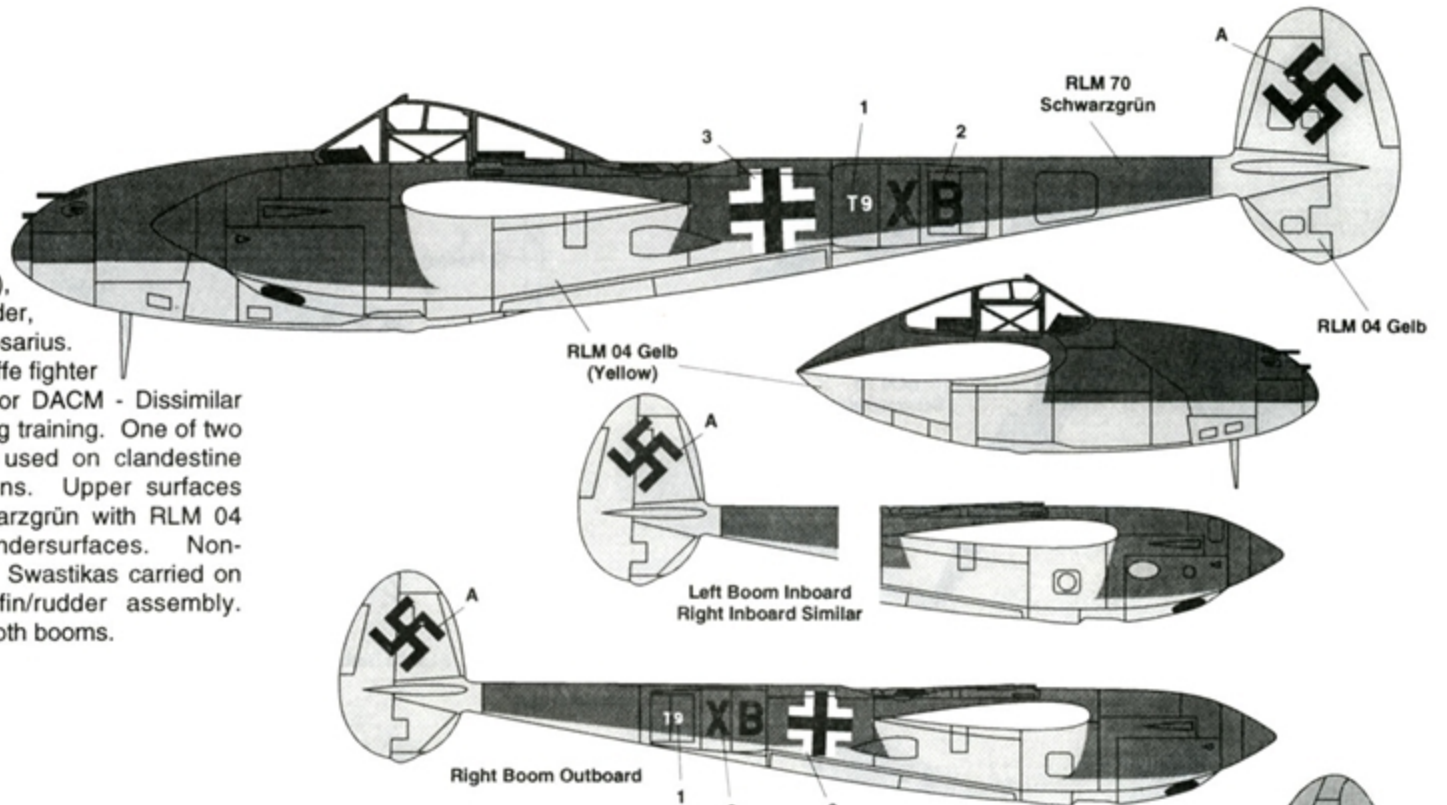

B

P-47D-2-RA 42-22490, flown by 2/Lt William E. Roach, 358th FS, 353rd FG. Landed in error at a Luftwaffe base in France on 7 November 1943. The captured "Beetle" was assigned to the Luftwaffe's Test and Research Center at Rechlin, retaining its USAAF camouflage of Olive Drab 41 over Neutral Gray 43 and unit and individual markings. "Beetle's" Red-bordered US national insignias were replaced with German crosses and its prop hub and entire engine cowl, less the access panels on both sides, were painted RLM 04. Note the thin White strip remaining on the panel. In early 1944, "Beetle" received new Blue-bordered US national insignia and White ID markings as well as its original USAAF serial, all applied in strict conformance with 8th AF directives, for use in a German war film. Note whip antenna.

US national insignia for these last two variations is not included on this sheet due to space limitations but are separately available.

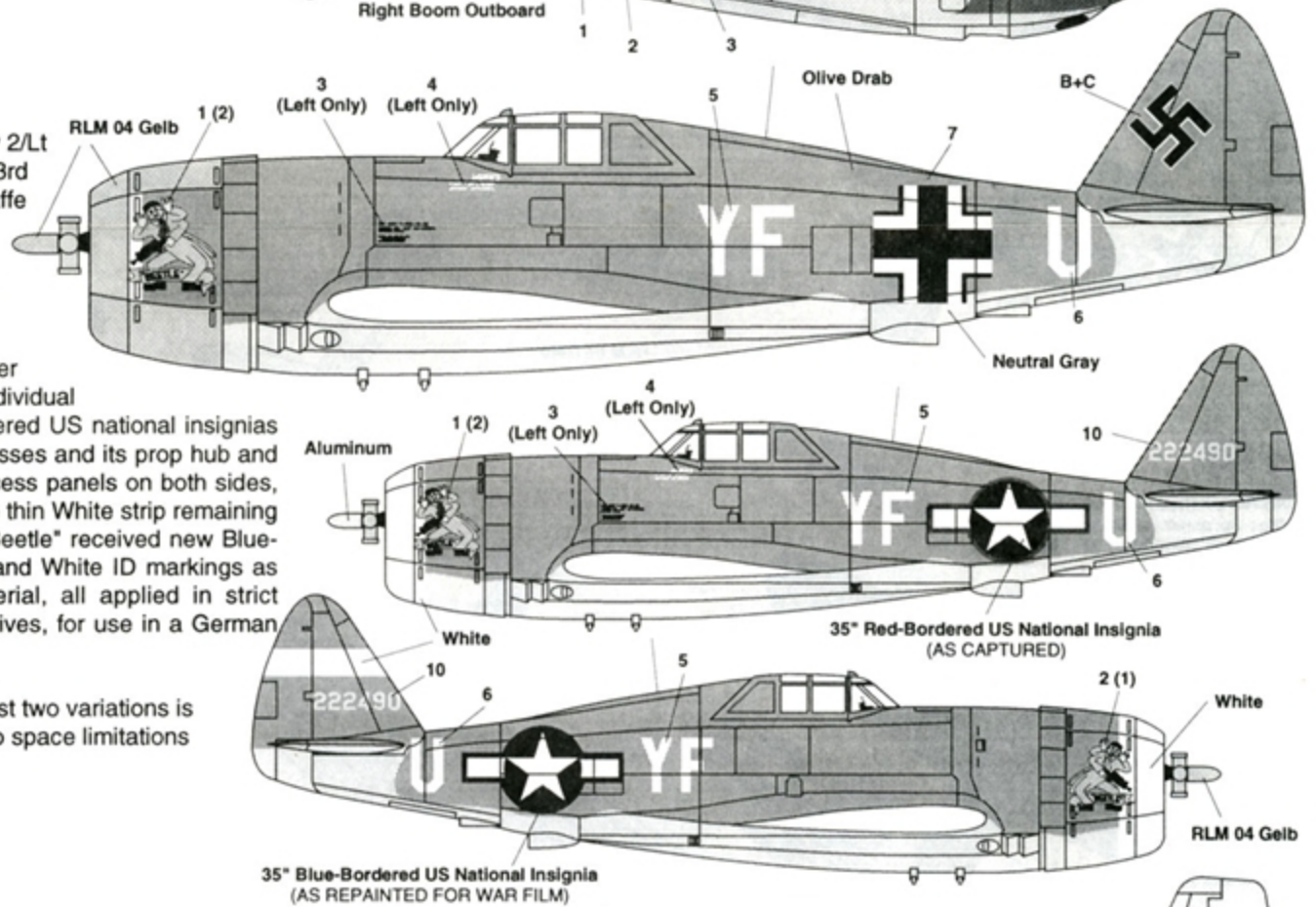

C

P-51C, serial unknown. Reportedly flown by a pilot named Strawbridge of the 51st FG. Captured intact in China during 1944 and flown to the Japanese Army Air Inspection Center at what is now Yokota Air Base. "Evalina" was finished in Natural Metal with a Dark Olive Drab anti-glare panel forward of the windscreen. The centers of her Blue star-in-circle national markings were overpainted with Hinomarus, but other unit, personal and victory markings were reportedly left intact. Available photos do not detail these markings nor do they show "Evalina's" full wing markings. A provisional data block and extra Hinomarus have been included. Note DF Loop Antenna installation.

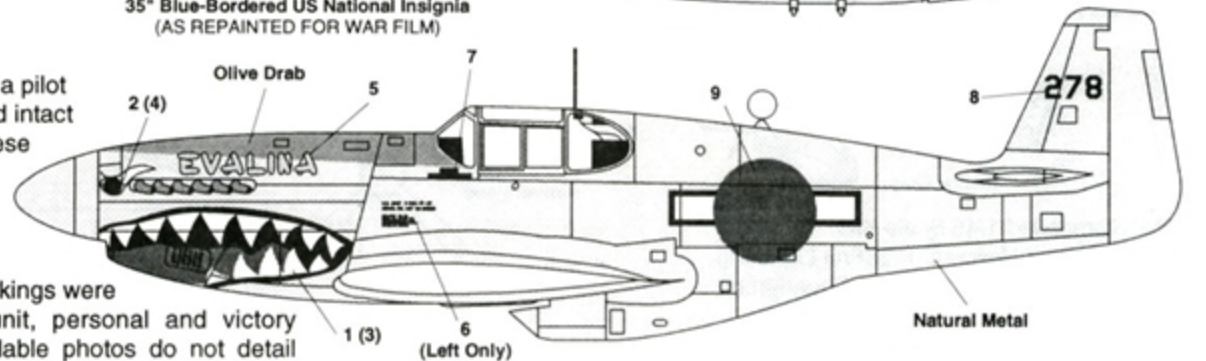

NOTE: Decals are to be applied to both left and right sides except as indicated on the drawings.

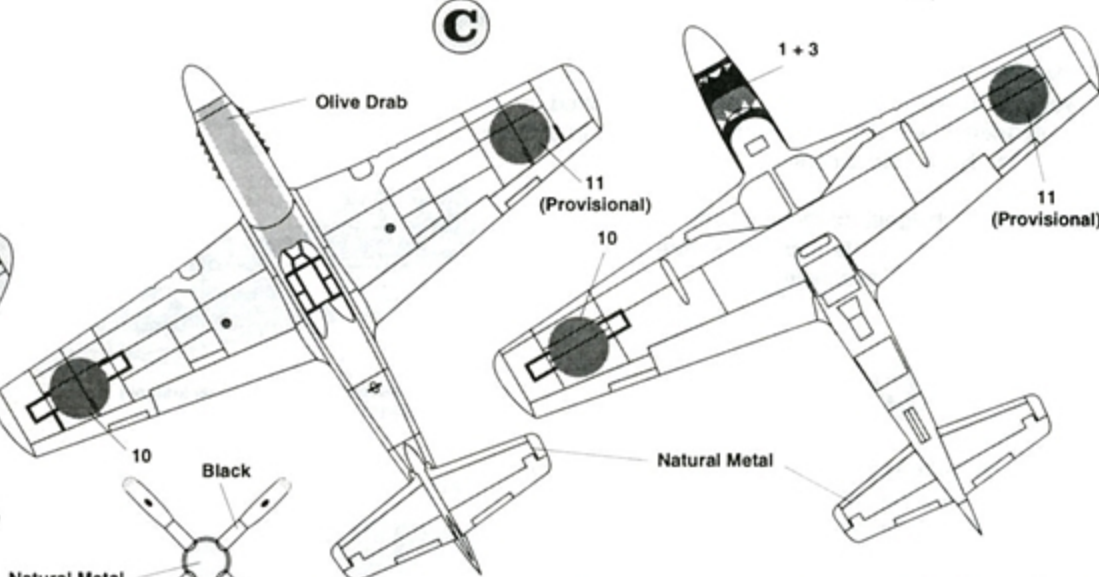
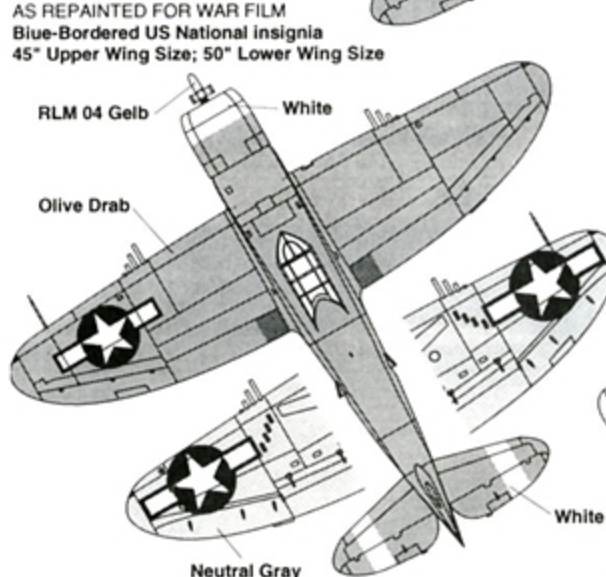
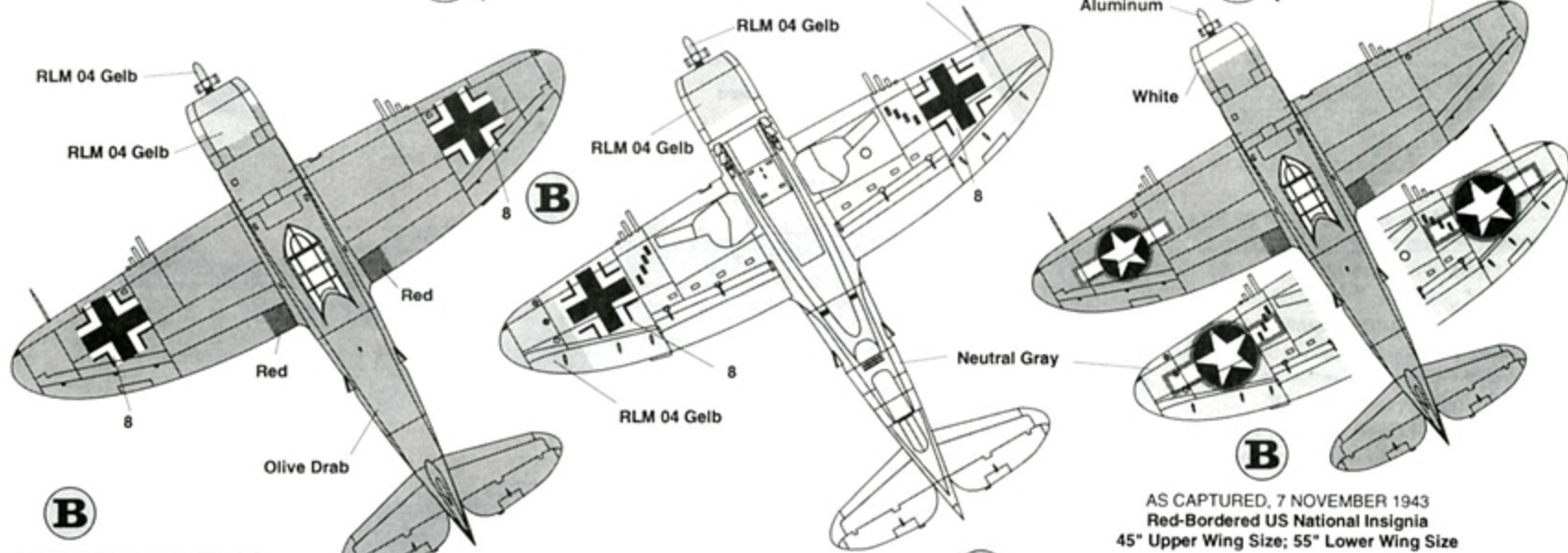
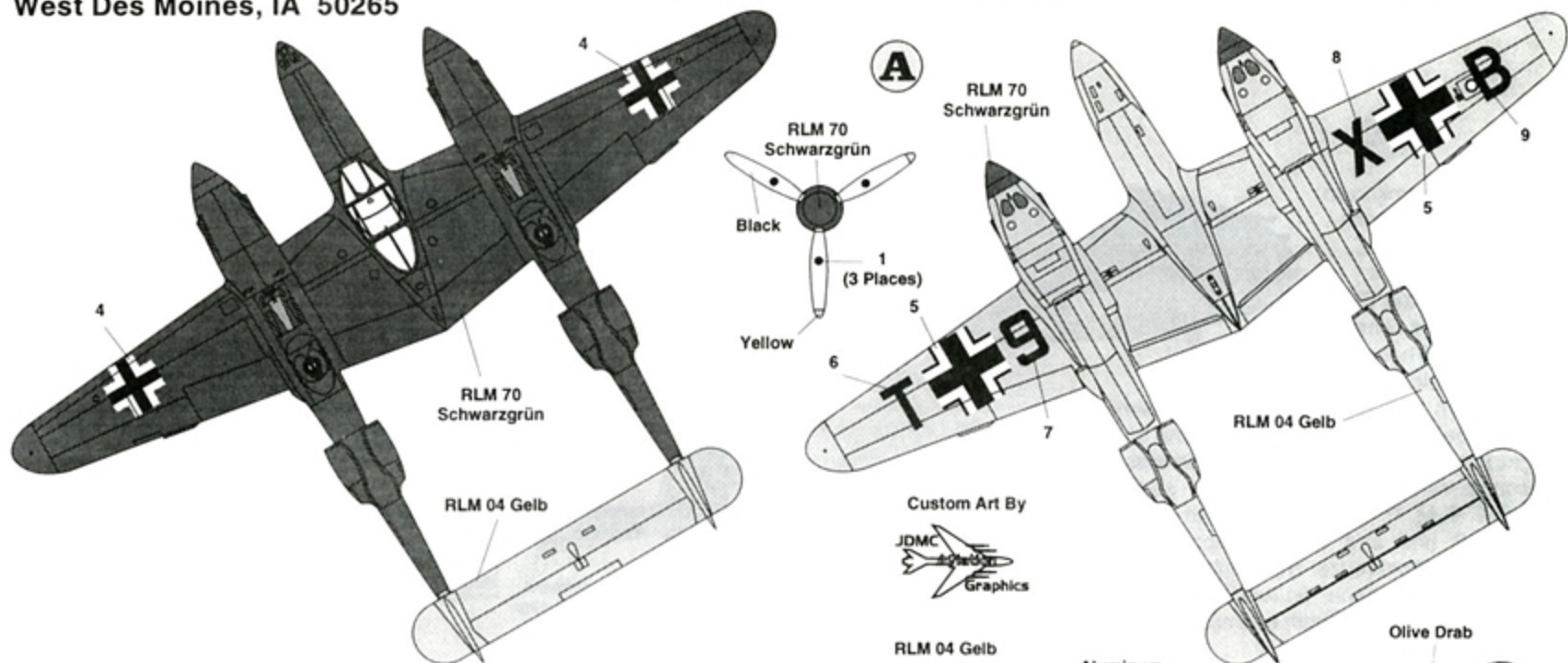

Recommended 1/48 Scale Kits:
 Hasegawa or Minicraft P-38F/G Lightning
 Monogram P-47D Razorback Thunderbolt
 Monogram P-51B Mustang

References:
 Strangers in a Strange Land, by Hans-Heiri Stapfer
 Mustang: A Documentary History, by Jeffrey Ethell

HELP! We need your help. There's lots of good stuff out there hiding in old Uncle Charlie's scrap book. Talk Uncle Charlie out of it for a little while and let us know. We're always looking for interesting aircraft to reproduce in decal form, and we need the assistance of modelers like you to find them. If you have anything you'd like to share, please contact us at the address above. We'll treat it just like it was our own Uncle Charlie's, and everything will be returned as it was received. Heck, we'll even give you a free decal when it's done!

Thanks,
 The Three Guys

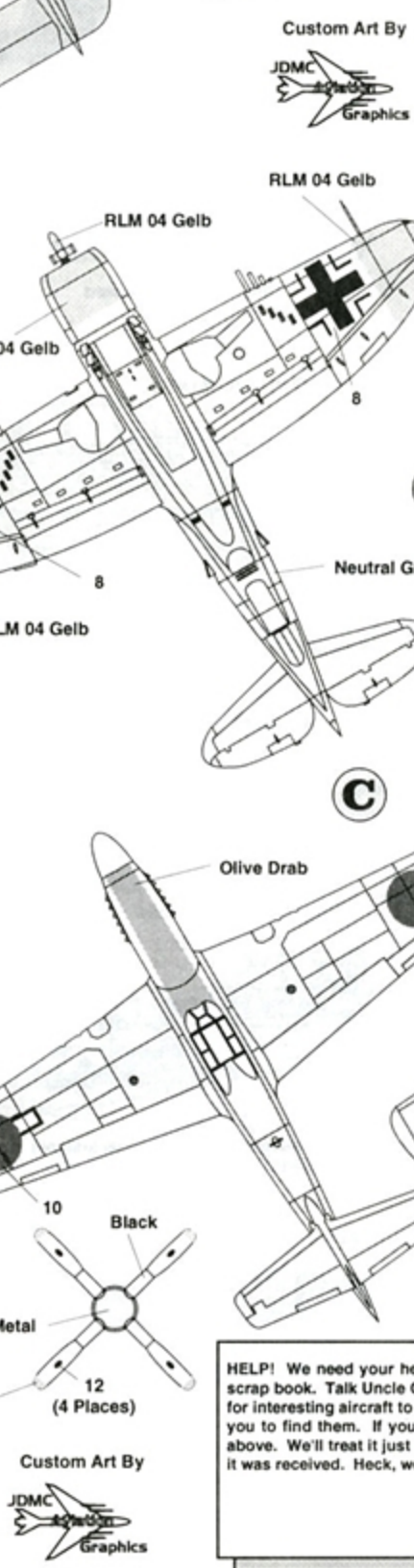

Errata Sheet:

In Enemy Hands I Captured USAAF Fighters

Sheet TGR48009
1/48 Scale

Sheet TGR72007
1/72 Scale

"Beetle" had an RLM 04 Gelb Rudder when flown in Luftwaffe markings after its capture. It was assigned to the 355th Fighter Group when captured on 7 November 1943.

