

de Havilland Vampire F.3/FB.5 Collection Pt1

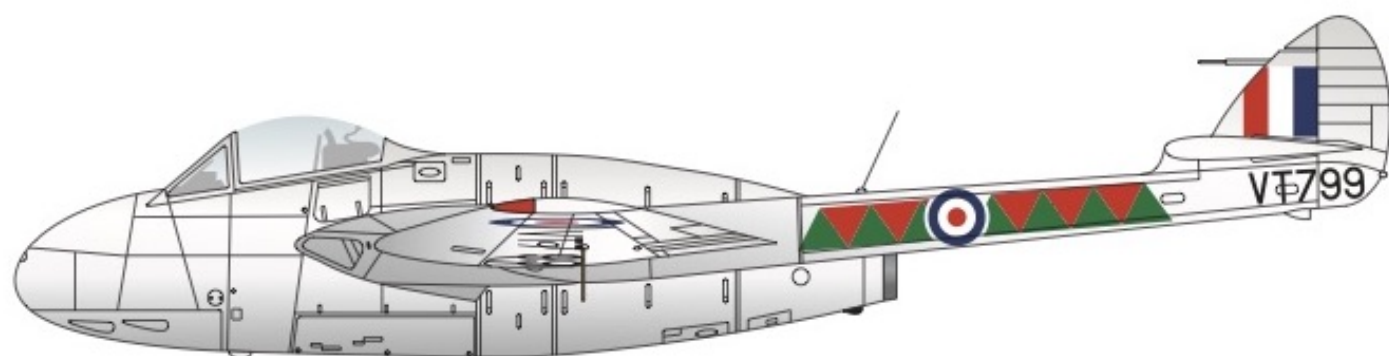
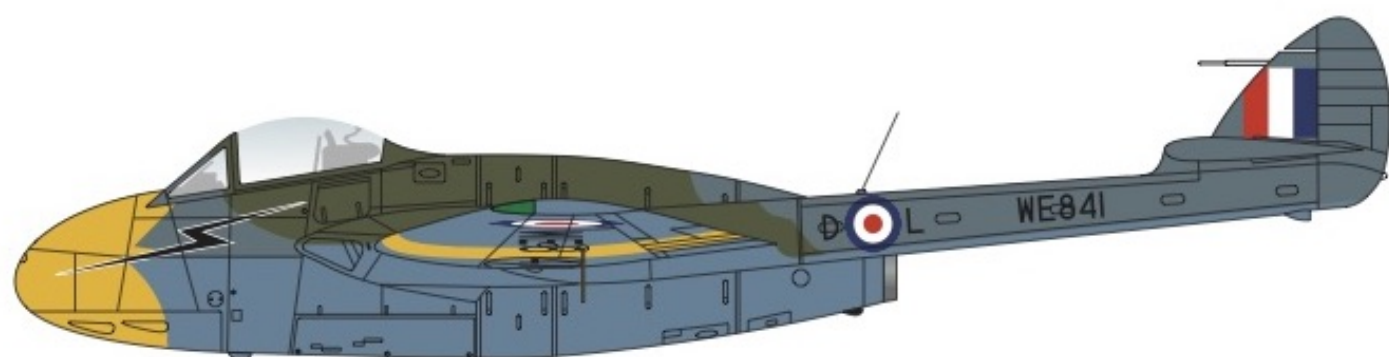

For the best results these decals should be applied to a gloss surface such as provided by either Xtracolor or Xtracrylix paints. Cut out the decal required and soak in warm water until the decal is released from the backing paper. Wet the area to be decaled with MICRO SET which will help to eliminate air trapped under the decal and position the decal.

After 5 or 10 minutes wet the decal with MICRO SOL which will soften the decal and ensure that it settles down over any surface detail. Allow the decal to dry for at least 12 hours. During this time some wrinkling of the decal may occur, this is normal. Do not touch the decal at this time.

Carefully check for small air bubbles and if there are any prick with a needle and apply a drop of MICRO SOL. After all air bubbles have been eliminated and the decals are dry wash the entire model with water to remove any excess decal adhesive.

When completely dry the whole model should be sprayed with a coat of Xtracolor or Xtracrylix Flat, Satin or Gloss varnish depending on the finish required.

Store in a cool dry place, avoid sunlight, dampness or extremes of temperature and/or humidity.

VT783 was finished in the overall High Speed Silver finish with Medium Blue rudders.

de Havilland Vampire FB.5
 WA106 'V'
 of 145 Squadron,
 Royal Air Force,
 based at RAF Celle,
 Germany,
 1952.

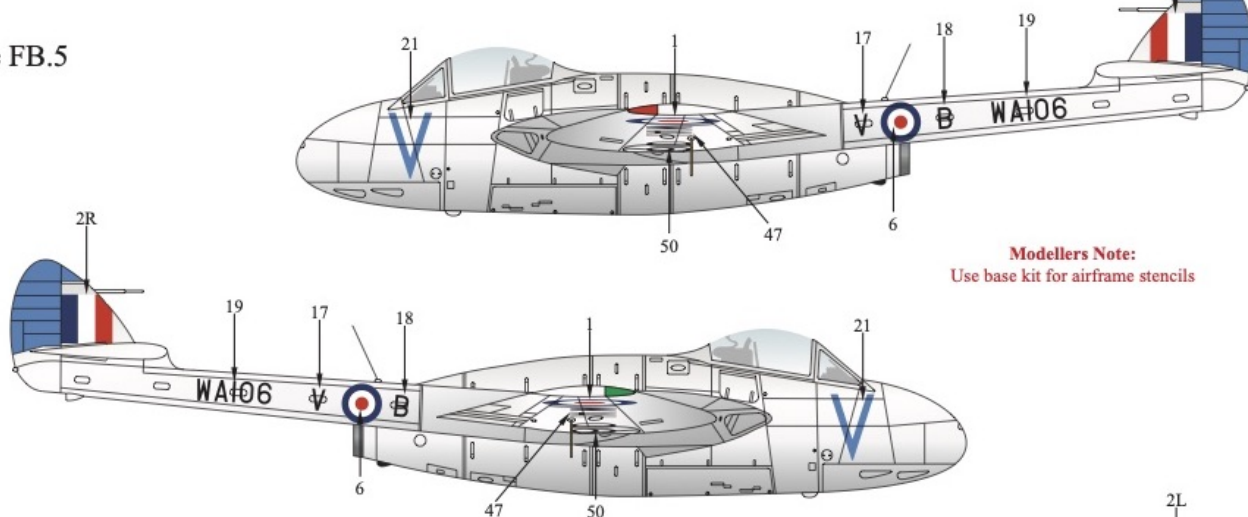

Modellers Note:
 Use base kit for airframe stencils

de Havilland Vampire FB.5
 WE841 'D.L'
 of 98 Squadron,
 during 'Operation Coronet'
 Royal Air Force,
 based at RAF Fassberg,
 Germany,
 July,
 1953.

WE841 had a BS381C:241 Dark Green and BS381C:638 Dark Sea Grey disruptive camouflage pattern over BS381C:636 PRU Blue undersides.
 BS381C:368 Golden Yellow nose and 24" wide wing trainer bands.

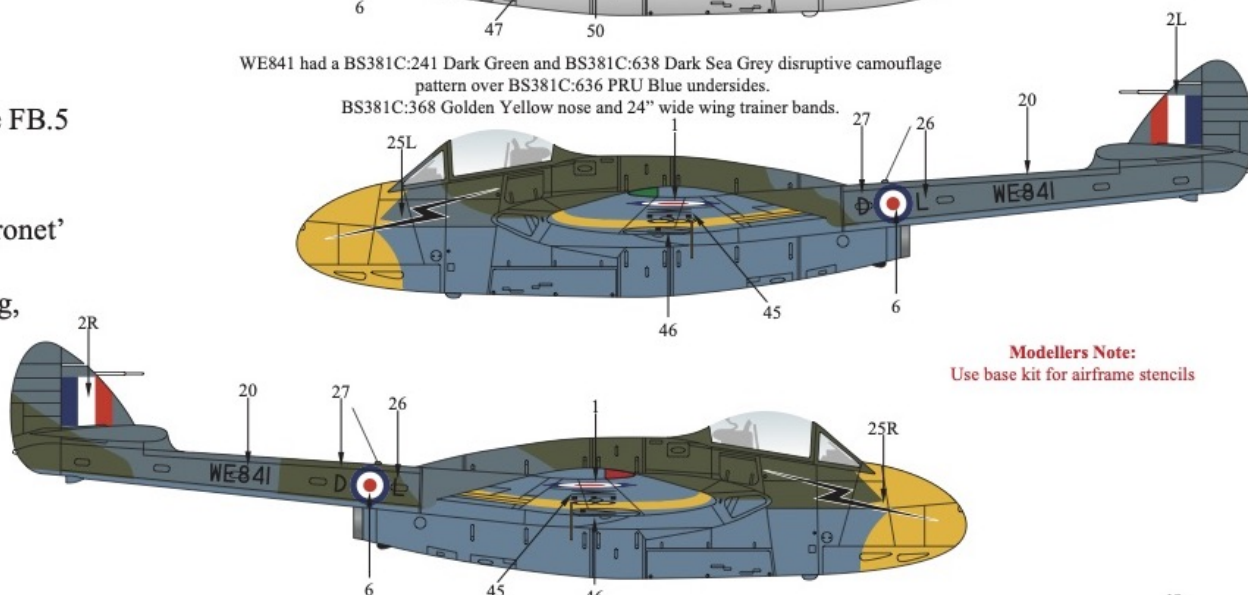

Modellers Note:
 Use base kit for airframe stencils

de Havilland Vampire FB.5
 VV617 'A'
 of 607 (County of Durham) Squadron,
 Royal Auxillary Air Force,
 based at RAF Ouston,
 UK,
 1956.

VV617 had a BS381C:241 Dark Green and BS381C:638 Dark Sea Grey disruptive camouflage pattern over High Speed Silver undersides.
 BS381C:368 Golden Yellow wingtips and a Mauve nosegear door.

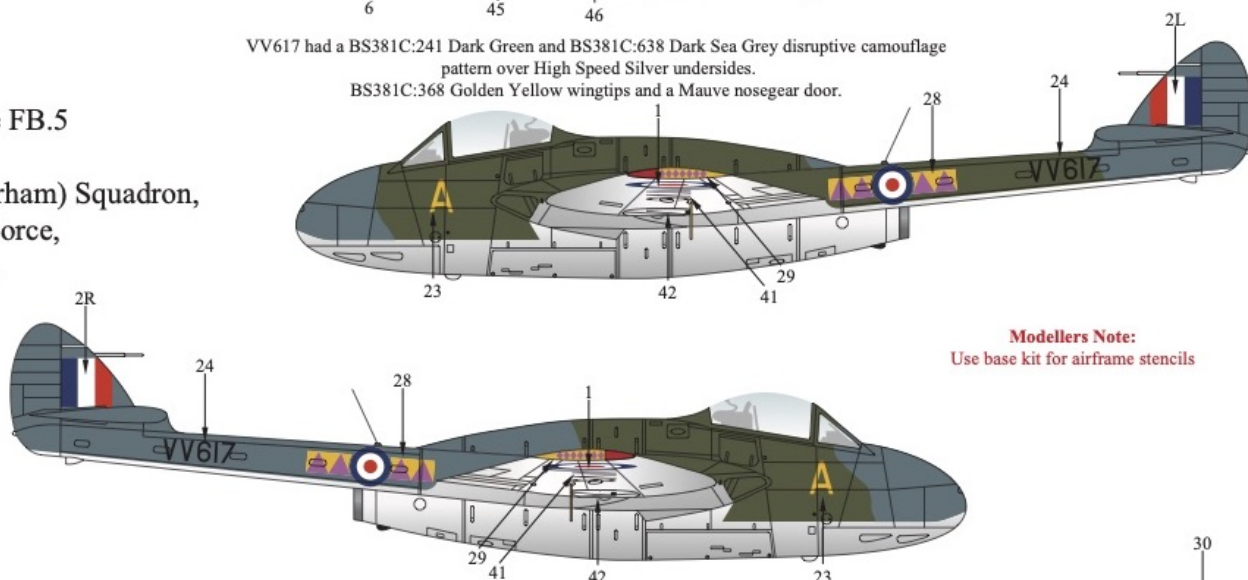

Modellers Note:
 Use base kit for airframe stencils

de Havilland Vampire FB.5
 WA163, 'G.L'
 flown by Commanding Officer
 Squadron Leader Hardy
 of 71 (Eagle) Squadron,
 Royal Air Force,
 based at RAF Gutersloh,
 Germany,
 August,
 1951.

WA163 was finished in an overall High Speed Silver finish with BS381C: 110 Roundel Blue fins and nosegear door.

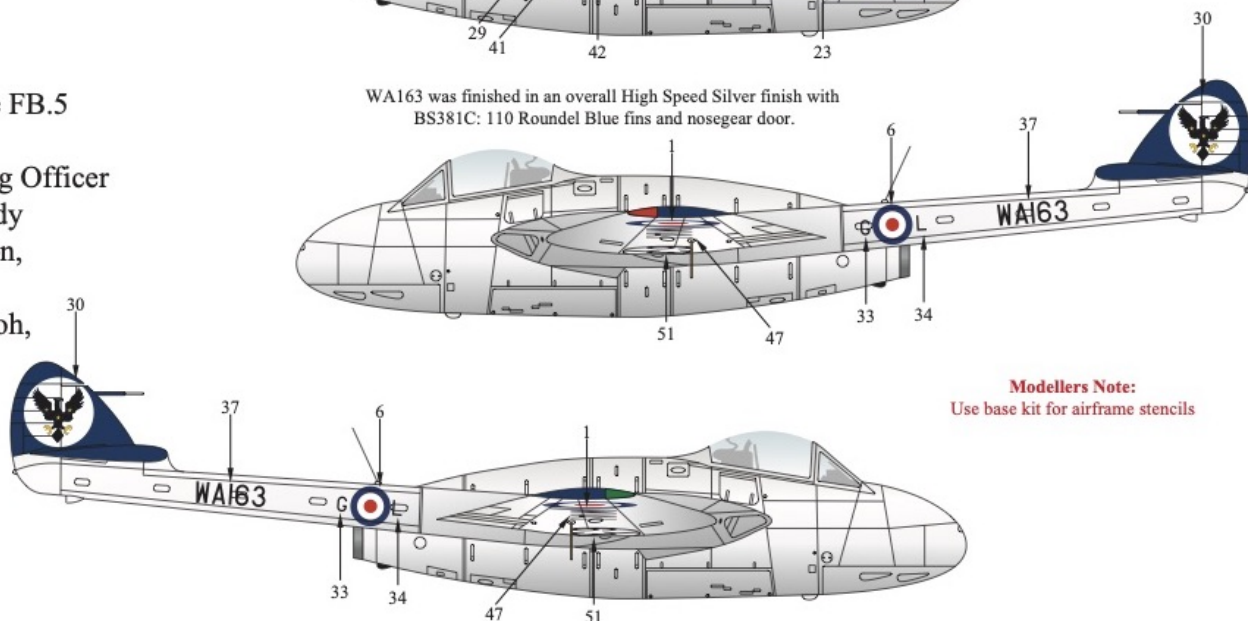

Modellers Note:
 Use base kit for airframe stencils

VT783 was finished in an overall High Speed Silver finish with a BS381C:537 Signal Red nosegear door.

de Havilland Vampire F.3
 VT783 'G'
 of 601 (County of London) Squadron,
 Royal Auxillary Air Force,
 based at RAF North Weald,
 UK,
 1952.

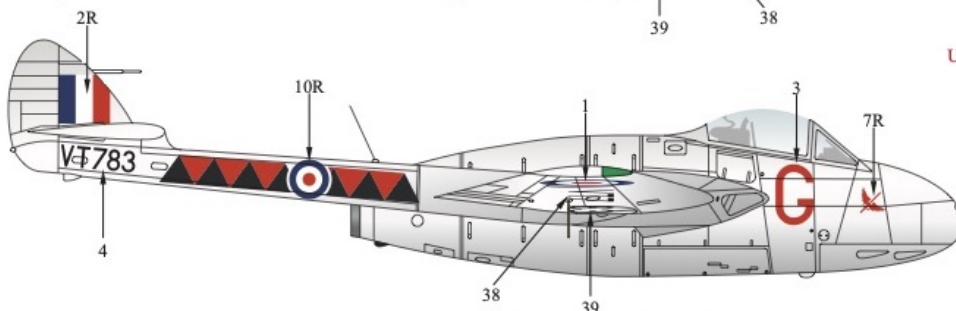
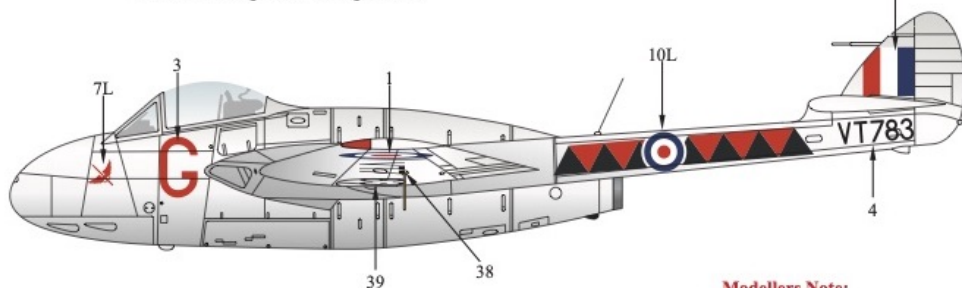

Modellers Note:
 Use base kit for airframe stencils

de Havilland Vampire FB.5
 VZ230 'X'
 of 73 Squadron,
 Royal Air Force,
 Near East Air Force,
 based at RAF Takali,
 Malta,
 1950.

VZ230 was finished in an overall High Speed Silver finish with a Pale Blue nosegear door.

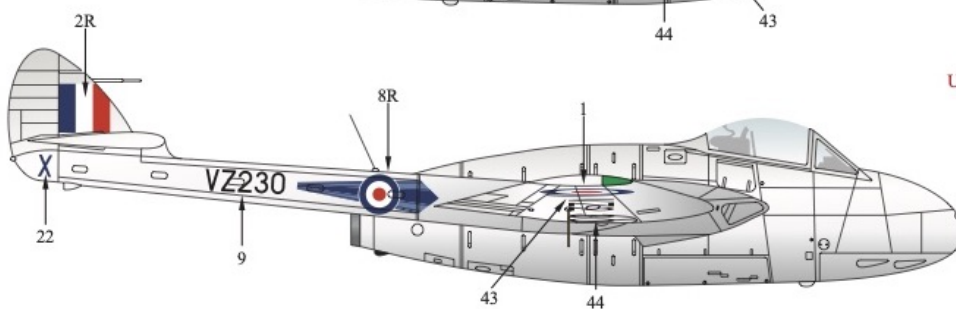
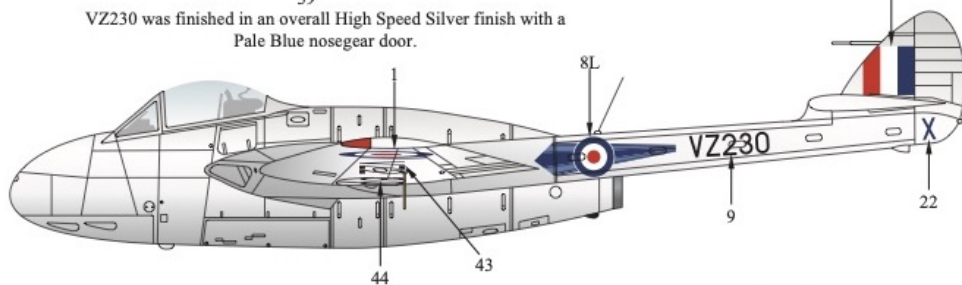

Modellers Note:
 Use base kit for airframe stencils

de Havilland Vampire FB.5
 VV632 'E'
 of 613 (City of Manchester) Squadron,
 Royal Auxillary Air Force,
 based at RAF Ringway,
 UK,
 1955.

VV632 was finished in an overall High Speed Silver finish with a BS381C:241 Dark Green and BS381C:638 Dark Sea Grey disruptive pattern applied to the upper surfaces.

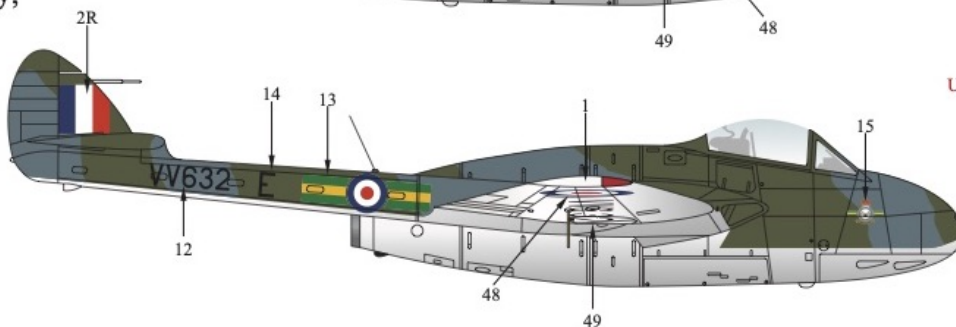
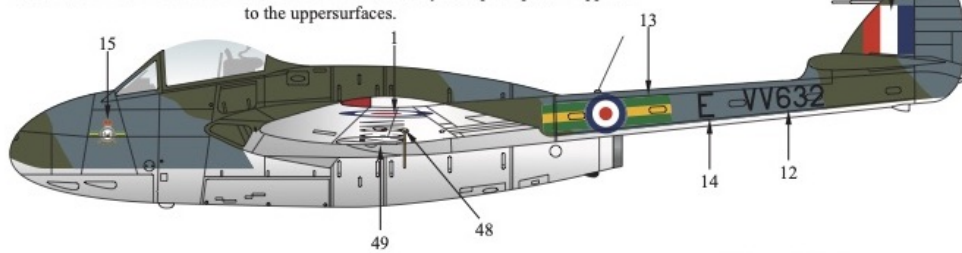

Modellers Note:
 Use base kit for airframe stencils

de Havilland Vampire F.3
 VT799
 of 614 (County of Glamorgan) Squadron,
 Royal Auxillary Air Force,
 based at RAF Llandow,
 UK,
 1951.

VT799 was finished in an overall High Speed Silver finish.

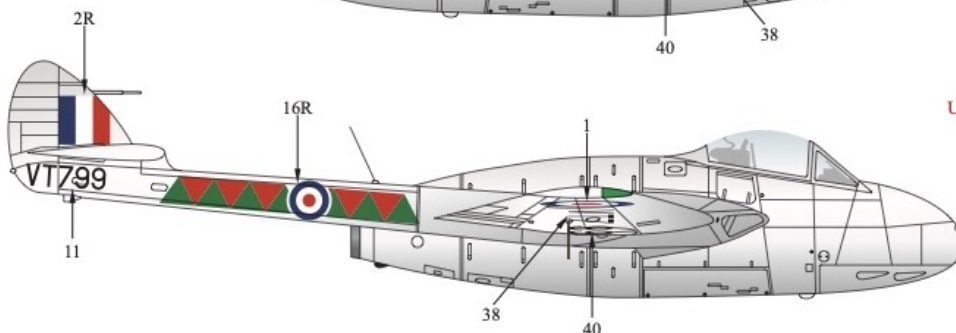
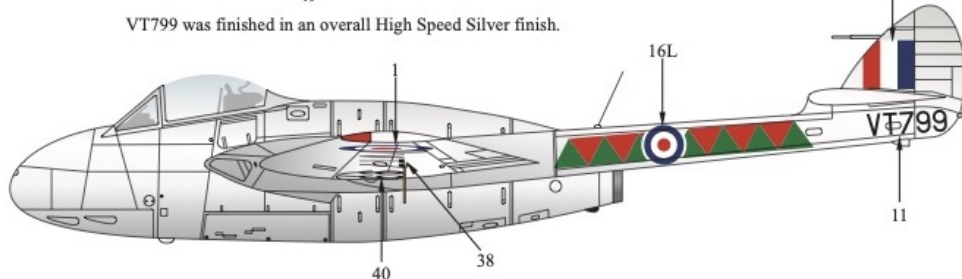

Modellers Note:
 Use base kit for airframe stencils

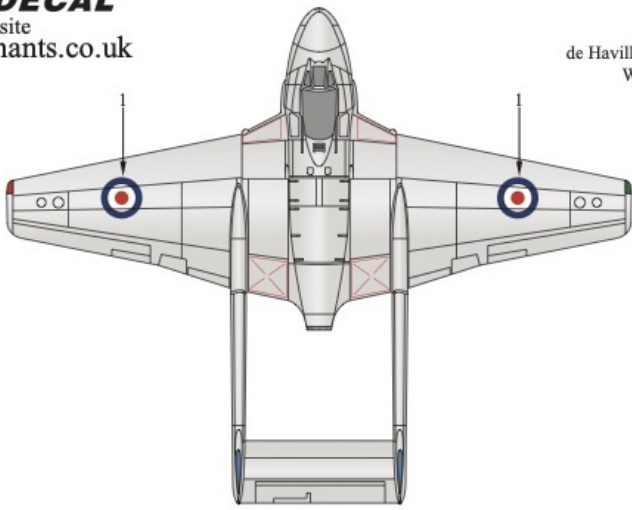

de Havilland Vampire FB.5
 WA106 'V'.

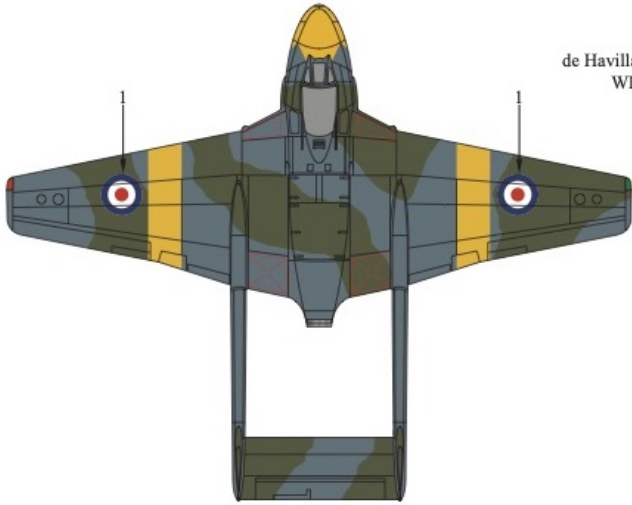
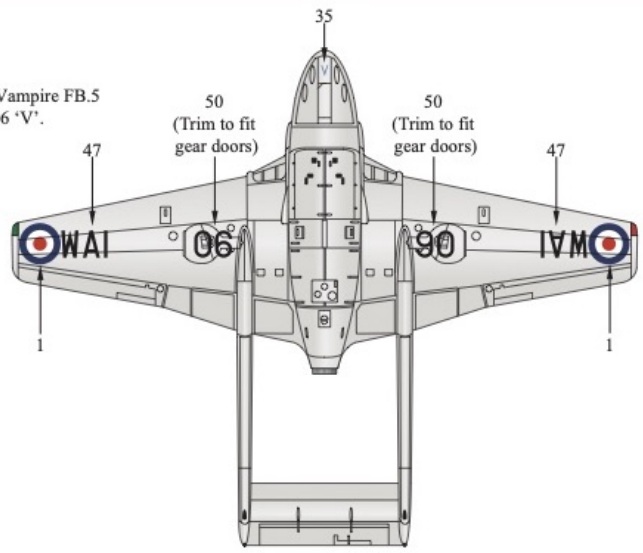

de Havilland Vampire FB.5
 WE841 'D.L'.

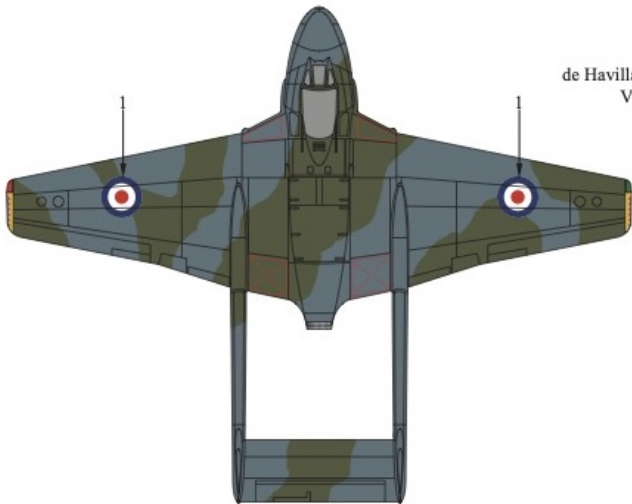
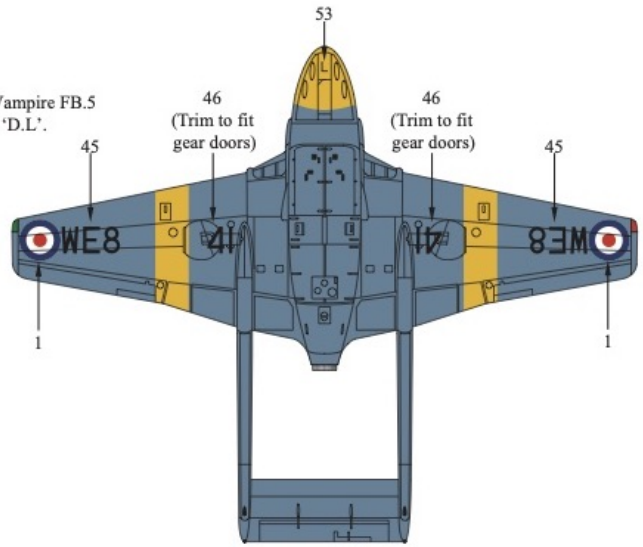

de Havilland Vampire FB.5
 VV617 'A'.

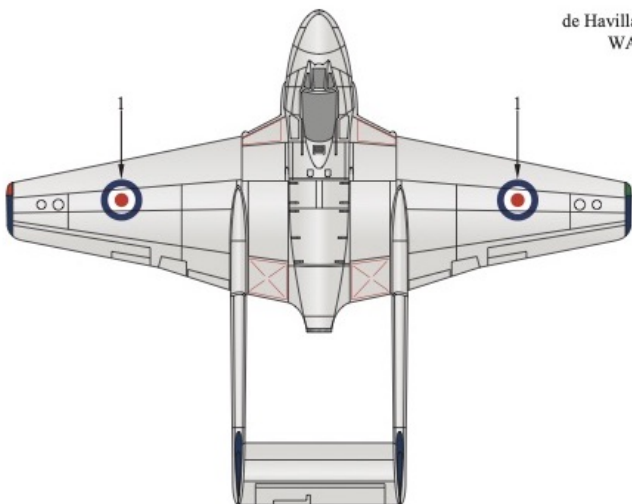
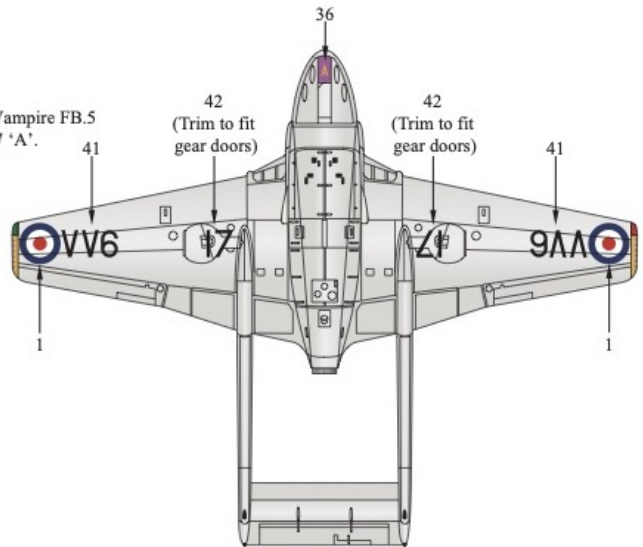

de Havilland Vampire FB.5
 WA163, 'G.L'.

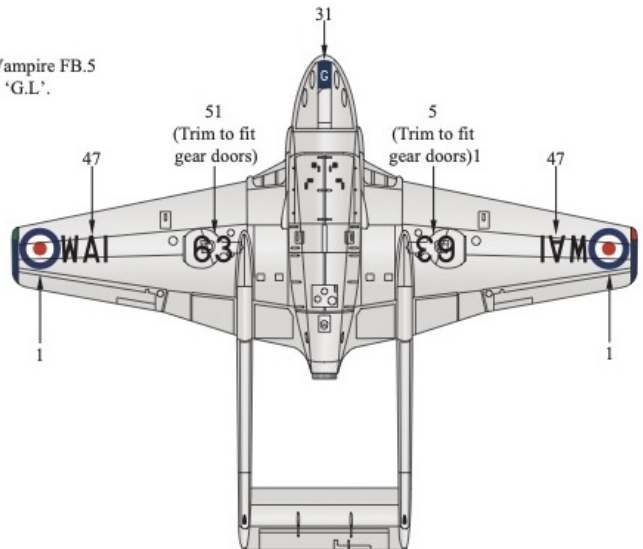

de Havilland Vampire F.3
 VT783 'G'.

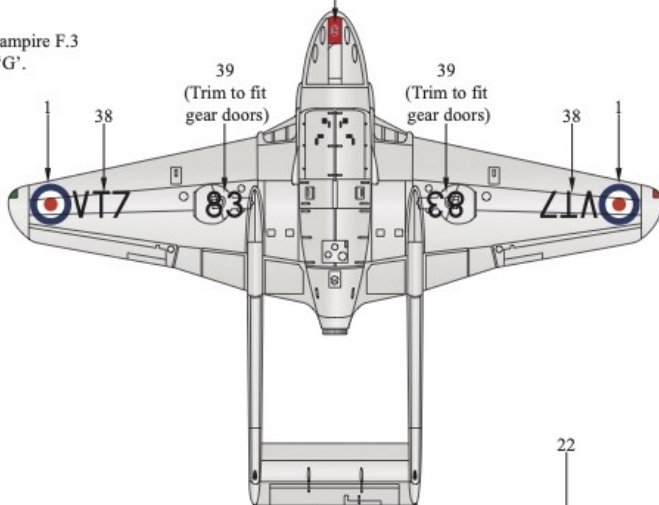
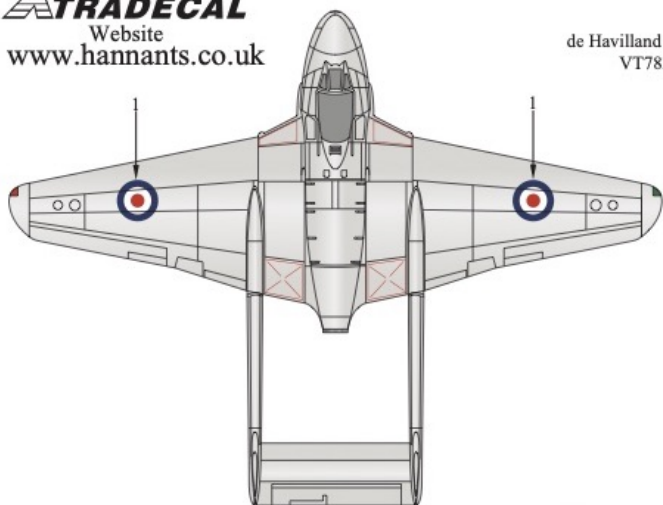

de Havilland Vampire FB.5
 VZ230 'X'.

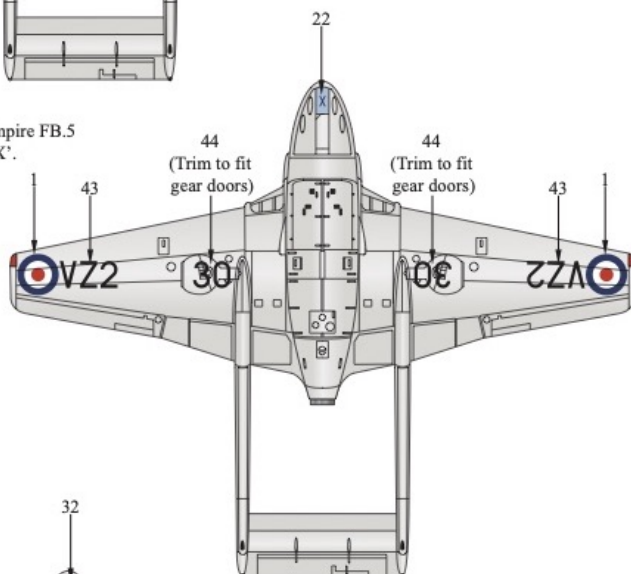
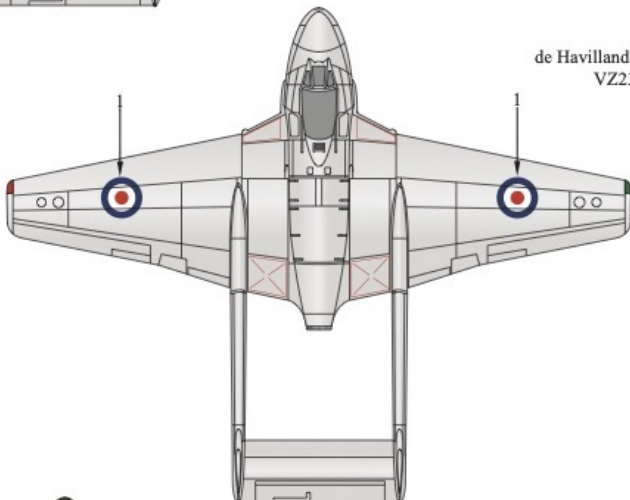

de Havilland Vampire FB.5
 VV632 'E'.

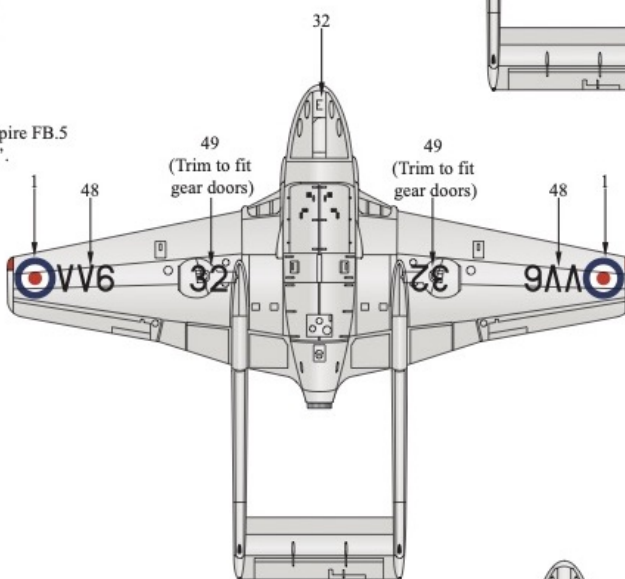
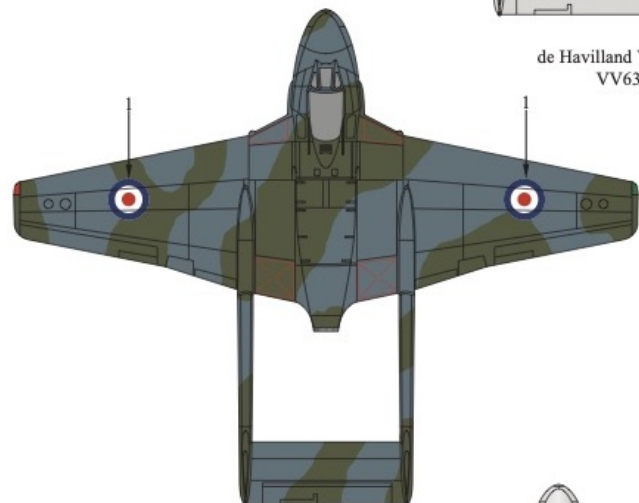

de Havilland Vampire F.3
 VT799.

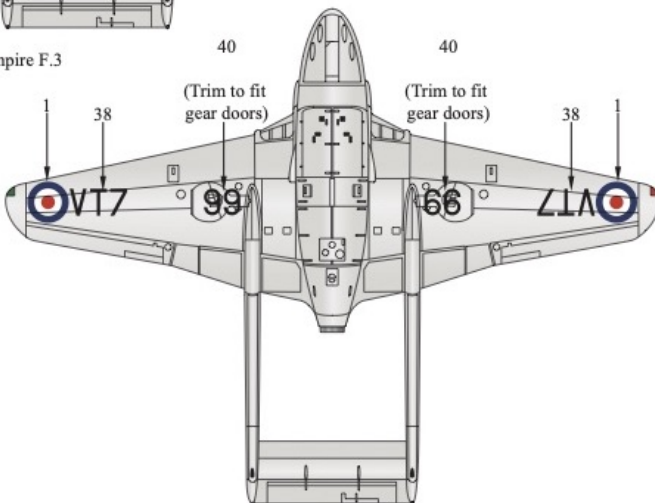
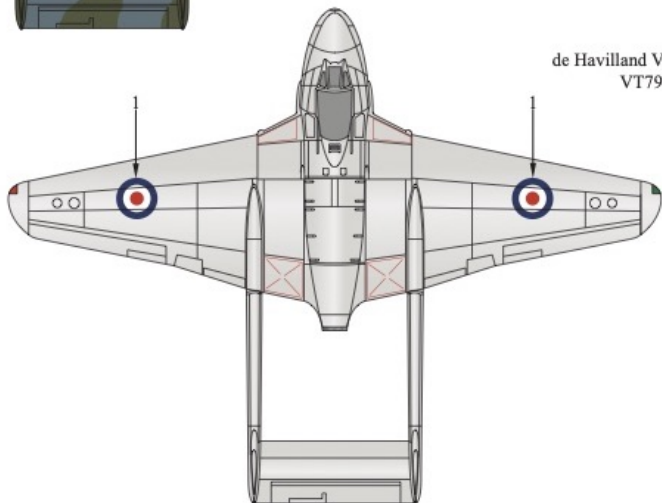

Xtracolor Paints

- X001 BS381C:241 Dark Green
- X004 BS381C:638 Dark Sea Grey
- X008 BS381C:636 PRU Blue
- X011 BS381C:368 Trainer Yellow
- X014 BS381C:537 Signal Red
- X030 BS381C:110 Roundel Blue
- X141 Insignia White
- X404 Matt Black
- X501 Silver

Paints:

The colours used on these aircraft can be found in the Xtracolor (prefix number with X) and Xtracrylix (prefix number with XA1) range of paints.

Xtracolor Paints

- XA1001 BS381C:241 Dark Green
- XA1004 BS381C:638 Dark Sea Grey
- XA1008 BS381C:636 PRU Blue
- XA1011 BS381C:368 Trainer Yellow
- XA1014 BS381C:537 Signal Red
- XA1030 BS381C:110 Roundel Blue
- XA1017 BS381C:626 Barley Grey
- XA1141 Insignia White