

F-86 GOPHER PATROL
335th FISq
AT KIMPO SUMMER 1942

PORT SIDE ONLY
BOTH SIDES

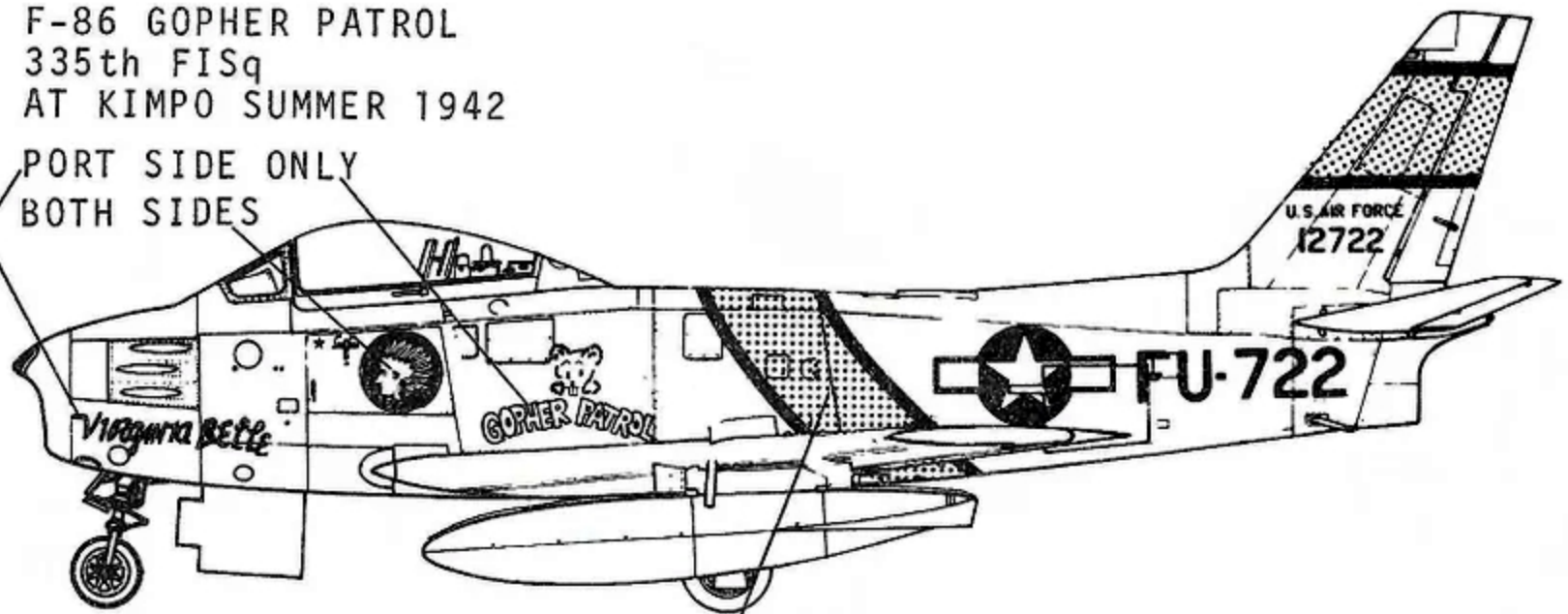

F-86A PEG O MY HEART
336th FISq, 4th FIWg
AT KIMPO IN 1952
PAINT YELLOW BEFORE DECALING
STARBOARD SIDE ONLY



F-86 WAM BAM
FLOWN BY LT. MARTIN BAMBRICK
WITH THE 336th FISq IN SUMMER 1952

PORT SIDE ONLY

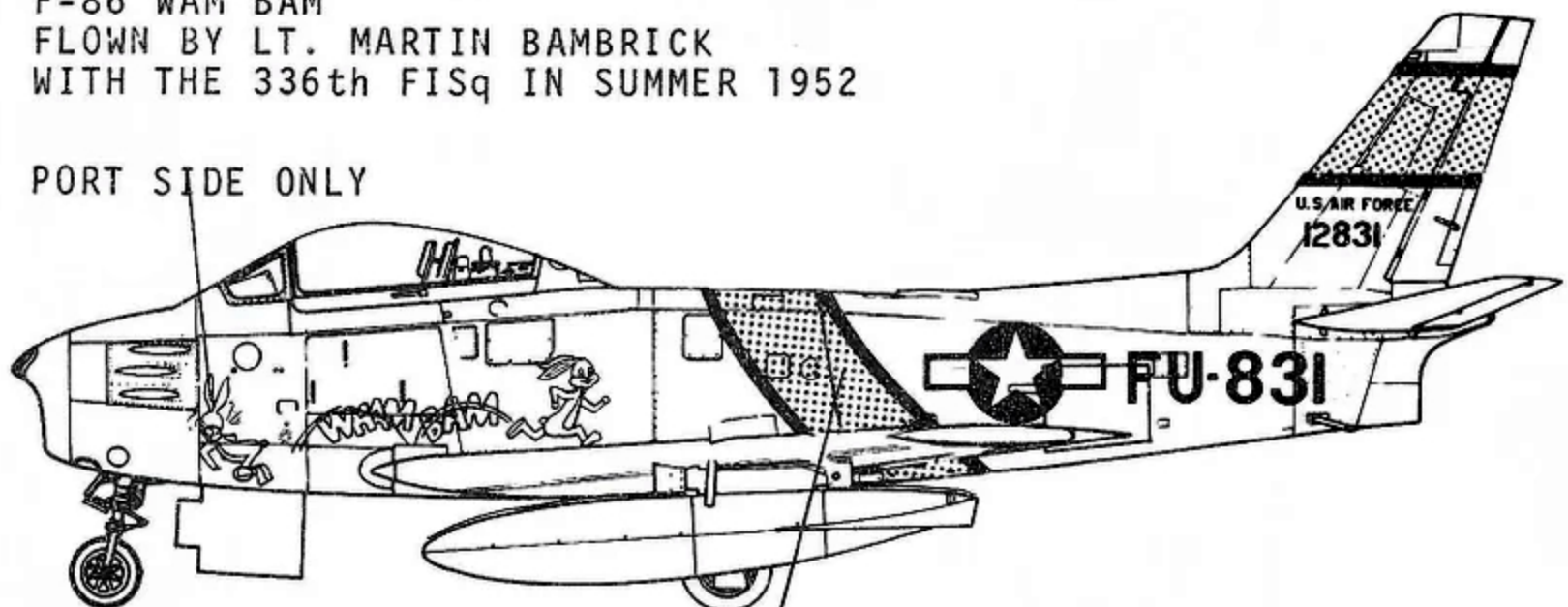

F-86E
39th FISq
SUWON, SPRING 1983.

PAINT YELLOW BEFORE DECALING
STARBOARD SIDE ONLY

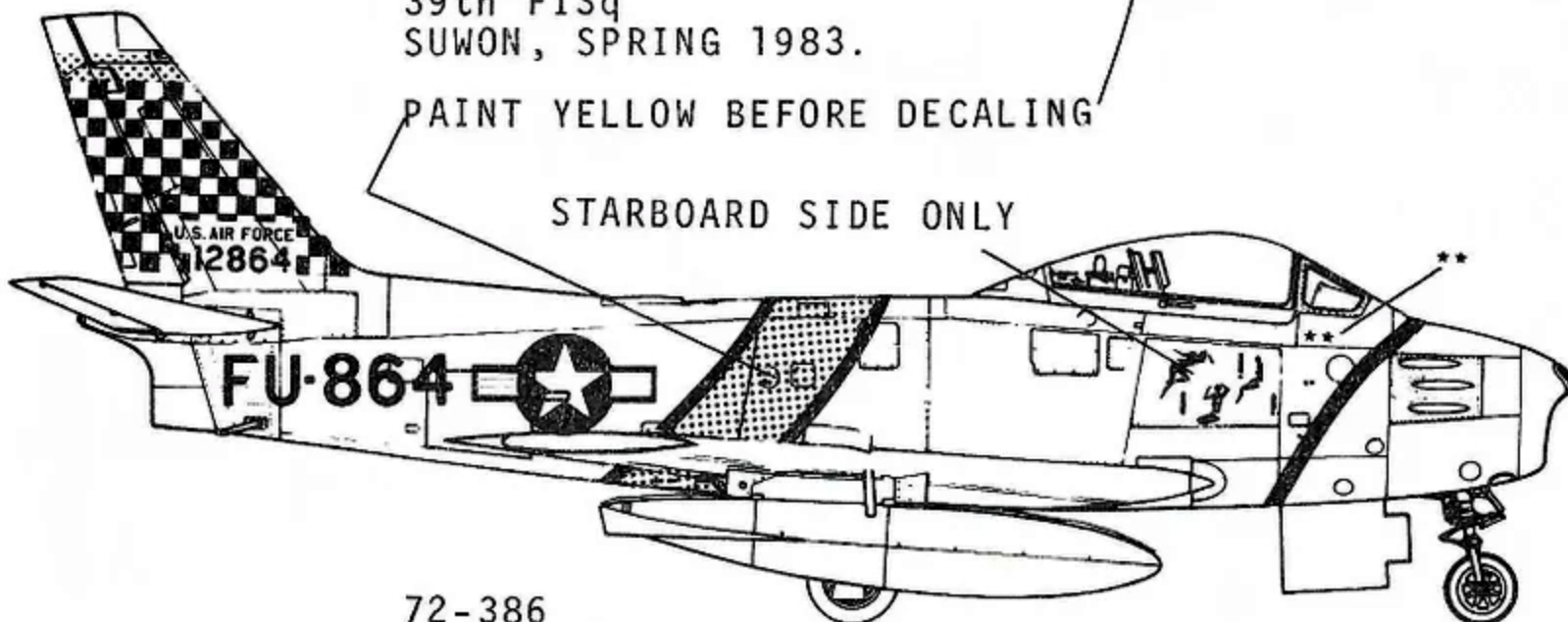

LEVELING PROVISION INSIDE

Markings common to all versions

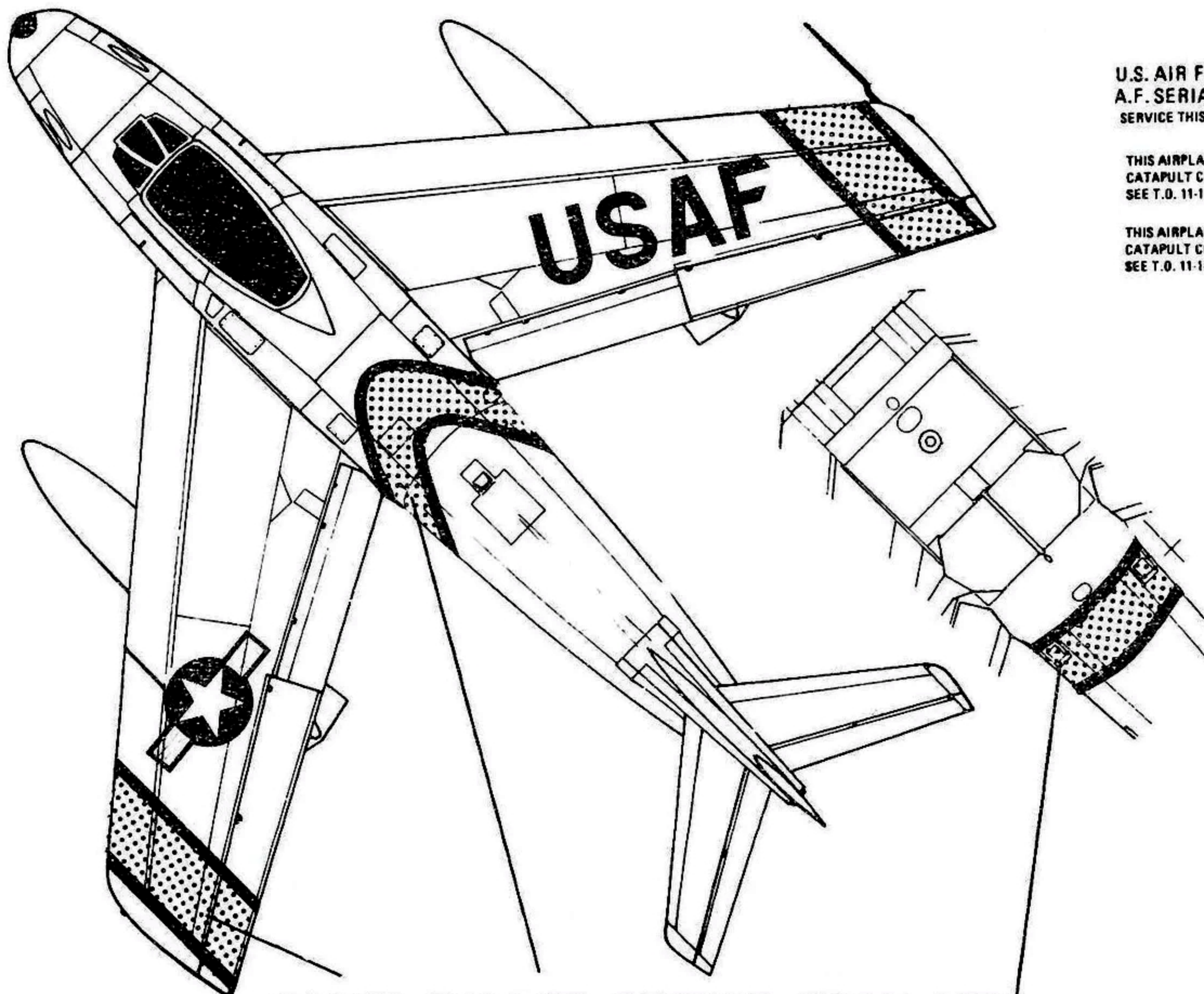
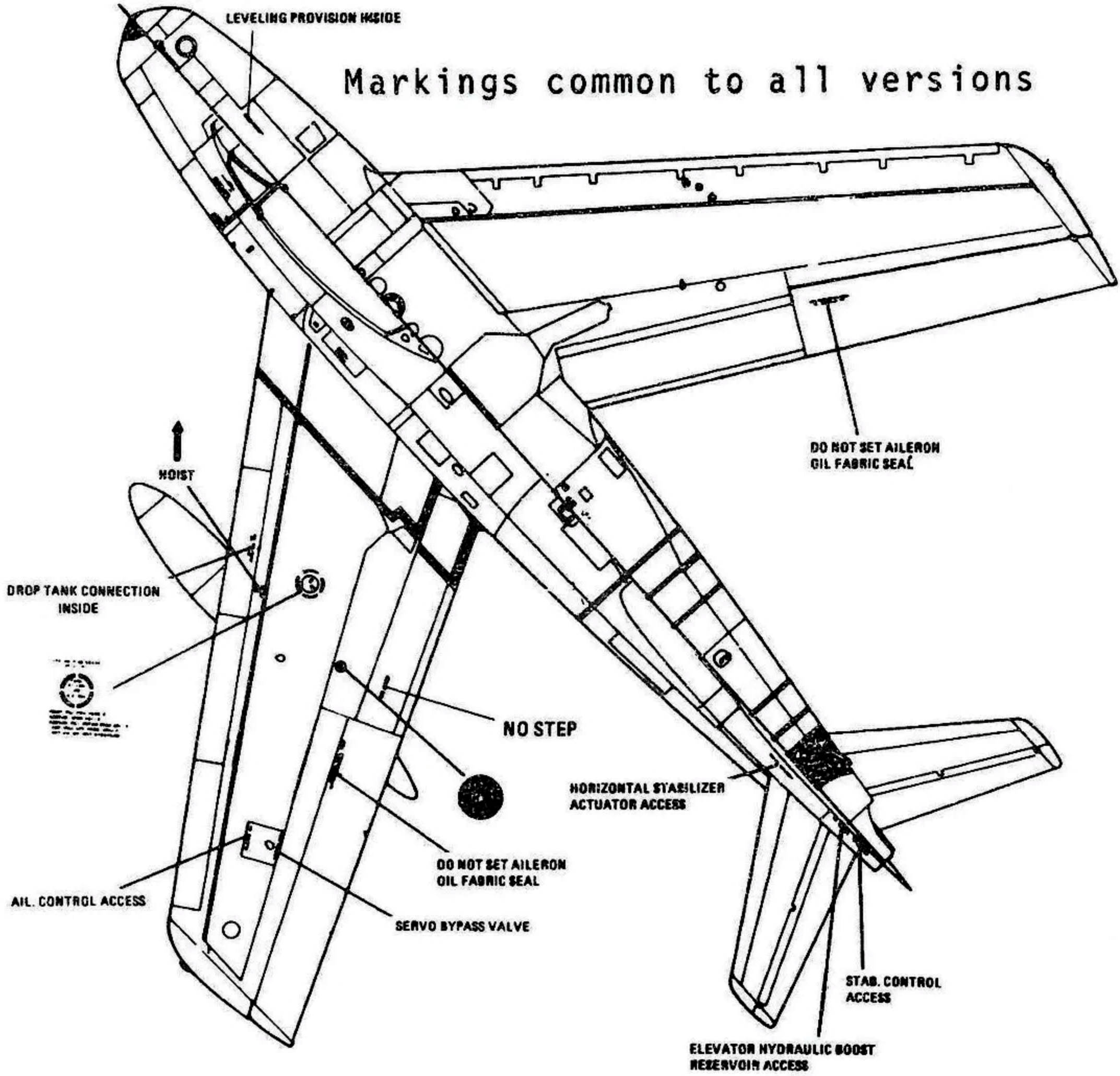

OVERALL AIRCRAFT IS NATURAL METAL ALL AIRCRAFTS

WARNING
THIS AIRPLANE CONTAINS A SEAT EJECTION CATAPULT CONTAINING AN EXPLOSIVE CHARGE SEE T.O. 11-1-99 FOR COMPLETE INSTRUCTIONS.

WARNING
THIS AIRPLANE CONTAINS A SEAT EJECTION CATAPULT CONTAINING AN EXPLOSIVE CHARGE SEE T.O. 11-1-99 FOR COMPLETE INSTRUCTIONS.

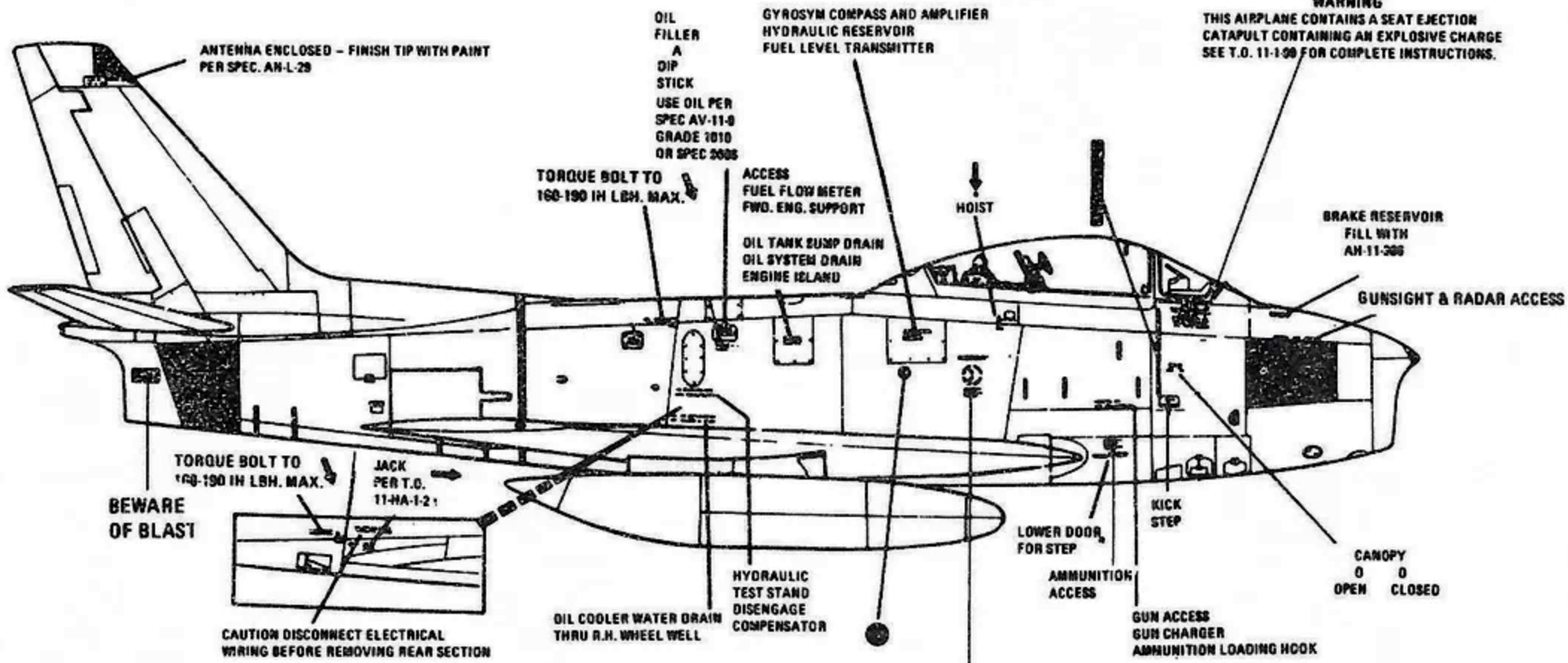

USE AN-F-32 GRADE JP-4 FUEL



FIRST-FWJ. FWD. FUSE. A CENTER WING CELLS SECOND-FILL OUTER WING CELLS LAST-FILL AFT. FUSE. CELLS CAUTION-DO NOT OVERFLOW

USE AN-F-32 GRADE JP-4 FUEL



FIRST-FWJ. FWD. FUSE. A CENTER WING CELLS SECOND-FILL OUTER WING CELLS LAST-FILL AFT. FUSE. CELLS CAUTION-DO NOT OVERFLOW

U.S. AIR FORCE F-86F-30-NA
A.F. SERIAL NO. 1 2 3 4 5 6 7 8 9 10
SERVICE THIS AIRPLANE WITH GRADE JP-4 FUEL

WARNING

THIS AIRPLANE CONTAINS A SEAT EJECTION CATAPULT CONTAINING AN EXPLOSIVE CHARGE SEE T.O. 11-1-99 FOR COMPLETE INSTRUCTIONS.

WARNING

THIS AIRPLANE CONTAINS A SEAT EJECTION CATAPULT CONTAINING AN EXPLOSIVE CHARGE SEE T.O. 11-1-99 FOR COMPLETE INSTRUCTIONS.

