

JF447, flown by S/Ldr. Stanisław Skalski, CO of No. 601 Squadron, Sicily, August 1943

After disbandment of the Polish Fighter Team (unofficially called Skalski's Circus) in June 1943, experimental unit formed by Polish pilots who, serving with No. 145 Squadron, were to gain experience in the air tactics in the ground units support, Stanislaw Skalski was offered the No. 601 Squadron's Commander post. As a unit leader he participated in Allies' landing in Sicily and the invasion of Italy. During that period he flew Spitfire Mk.VIII marked UF-7 camouflaged in colors applied to RAF aircraft operating in the North Africa. Upper and side surfaces were coated in Dark Earth and Middle Stone colors, lower surfaces were sprayed in Azure Blue. The aircraft carried No. 601 Squadron marking on the both sides of the vertical tail surface.

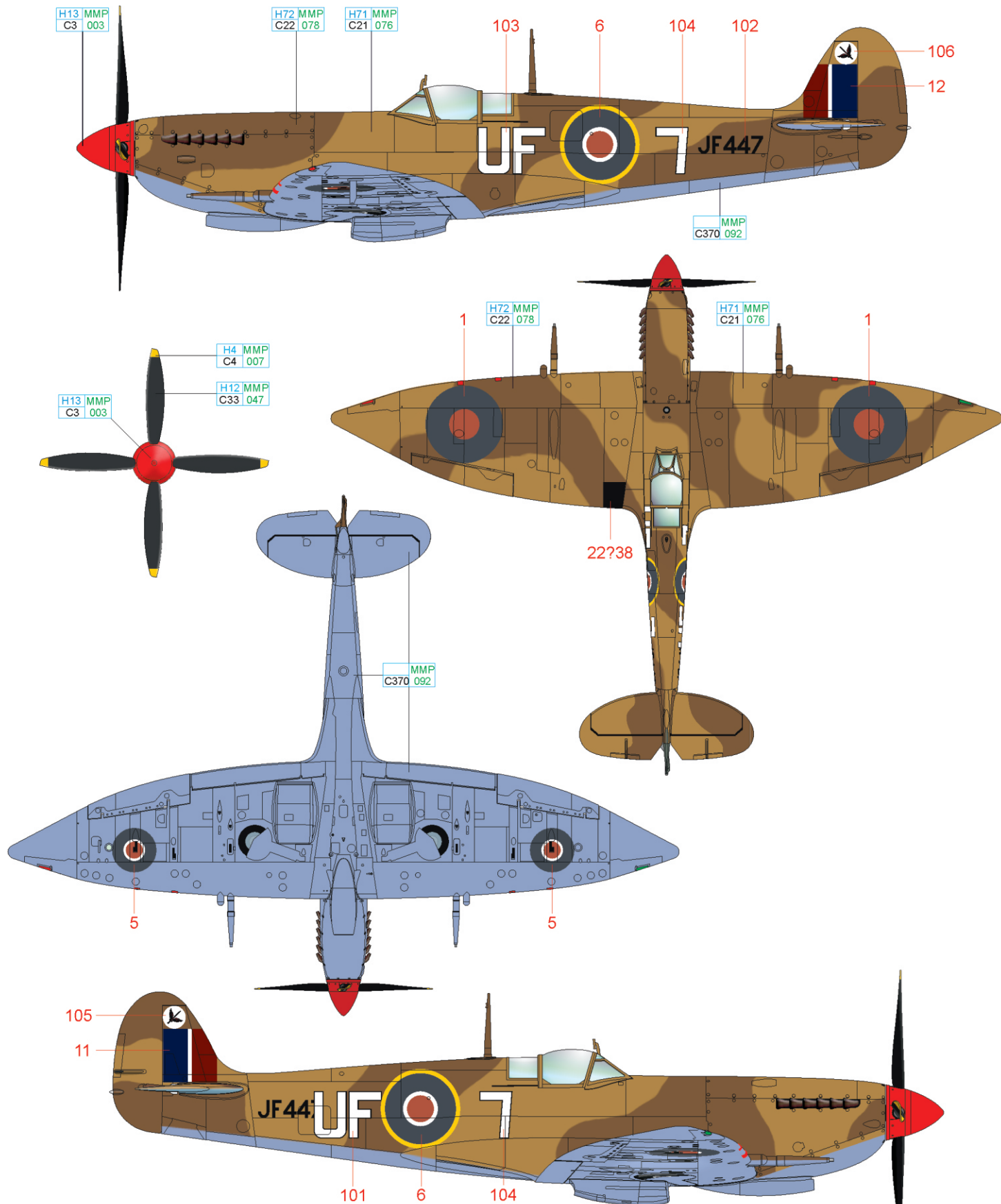

RED	H13 MMP C3 003	LIGHT YELLOW	H4 MMP C4 007
AZURE	MMP C370 092	MIDDLE STONE	H71 MMP C21 076
		DARK EARTH	H72 MMP C22 078
		BLACK	H12 MMP C33 047

Spitfire HF Mk.VIII

eduard

1/72 SCALE PLASTIC KIT

ProfiPACK
edition

#70129



INTRO

In September 1941, a hitherto unknown German radial engine fighter appeared in the west European sky. The new airplane was superior to British fighters, most distressingly to the Spitfire Mk.V. The German design was soon recognized as the Focke-Wulf Fw 190A. The losses suffered by the RAF over western Europe rose rapidly and the crisis was serious enough that the RAF ceased the majority of daytime operations in November 1941. The next attempt to resume these types of sorties was made in March 1942. Loss rates remained unacceptably high and the RAF was forced to stop ops once again. All this was thanks to the Focke-Wulf Fw 190A. The first response to the new German weapon was the Spitfire Mk.VIII, but the design changes were so complex that initiating timely production was not possible. In June 1942 a German pilot landed by mistake on a British airfield delivering a completely intact Fw 190 fighter into RAF hands. Comparative trials between the Focke-Wulf and Spitfire Mk.V began almost immediately. These mock encounters confirmed the situation over the front – the chances of a British fighter surviving an encounter with the Fw 190 were slim. The only British fighter aircraft deemed suitable to oppose them were the Spitfire Mk. VII and VIII powered by the Merlin 61 engine. As mentioned above these were some time away of being ready for series production. But there was another way of getting a powerful fighter quickly - by mating the Merlin 61, with its two-stage supercharger, with the fuselage of the Spitfire Mk.Vc. Two Mk.Vc airframes, AB196 and AB197, were selected for this purpose and were strengthened with modified longerons to accommodate the more powerful and heavier engine. The example was finished on February 26th and the second on March 27th, 1942. Flight trials were successful and the order for series production was issued almost immediately. Series production began in June 1942 and the first Mk.IXs found their way to No. 64 Squadron in July. Performance improved significantly in comparison to the Mk.V. A top speed of 409 mph at 28,000 feet was higher by 40 mph, and the service ceiling rose from 36,200 to 43,000 feet. The Mk.IX could climb at 4,000 feet per minute. The RAF finally had a fighter aircraft capable of opposing the Fw 190A. Three main versions of the Mk. IX were produced. The F.IX was powered by the Merlin 61 and was the only version on the assembly line in early 1943. The next version was the LF Mk.IX powered by the Merlin 66. This engine was designed to do its best at low altitudes. The third version, manufactured along with the LF, was the high-altitude HF Mk.IX with the Merlin 70. The majority of Mk.IXs manufactured were equipped with the so-called 'C' wing. Four 20 mm cannons or two 20 mm cannons and four .303 machine guns could be installed in the wings. From 1944 the strengthened 'E' wing was produced. Four .303 machine guns were replaced with two .50 heavy machine guns. Bomb racks for 250 lb bombs were fitted under each wing typically. The Mk.IX became the second most numerous version of the Spitfire with a total of 5653 examples being built. The Mk.IX began to replace the Mk.V from June 1942. Thanks to the new fighter, the RAF was ready to fight against the Luftwaffe over occupied Europe. Spitfire Mk.IXs served with the RAF to the end of war. In the postwar era, foreign air forces flew this version as well. Czechoslovak, Norwegian, Danish, and Canadian air forces operated numbers of Mk.IXs and they were not alone. Spitfires would find themselves in combat again. Czechoslovakia sold its Spitfire Mk.IXs to Israel in 1948 and these aircraft formed the backbone of the newly born Israeli air force in the fight against their Arab neighbours.



Carefully read instruction sheet before assembling. When you use glue or paint, do not use near open flame and use in well ventilated room. Keep out of reach of small children. Children must not be allowed to suck any part, or pull vinyl bag over the head.



Před započítím stavby si pečlivě prostudujte stavební návod. Při používání barev a lepidel pracujte v dobře větrané místnosti. Lepidla ani barvy nepoužívejte v blízkosti otevřeného ohně. Model není určen malým dětem, mohlo by dojít k požití drobných dílů.

INSTRUCTION SIGNS * INSTR. SYMBOLS * INSTRUKTION SINNBILDEN * SYMBOLES * 記号の説明



OPTIONAL
VOLBA



BEND
OHNOU



SAND
BROUSIT



OPEN HOLE
VYVRTAT OTVOR



SYMMETRICAL ASSEMBLY
SYMETRICKÁ MONTÁŽ



REMOVE
ODŘÍZNOUT



REVERSE SIDE
OTOČIT



APPLY EDUARD MASK
AND PAINT
POUŽÍT EDUARD MASK
NABARVIT

PARTS



DÍLY



TEILE



PIÈCES



部品

PLASTIC PARTS

A>

70120 A

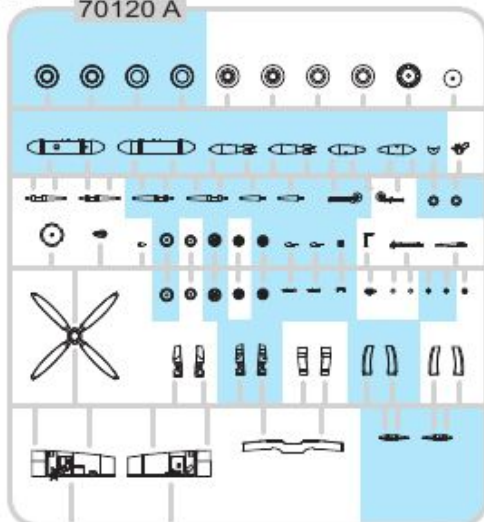

B>

70120 B

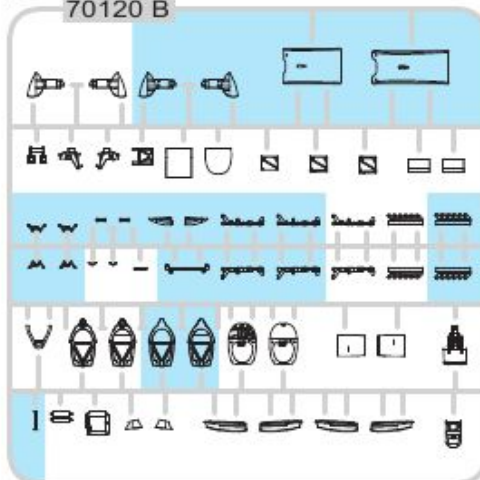

C>

70120 C



D>

70120 D

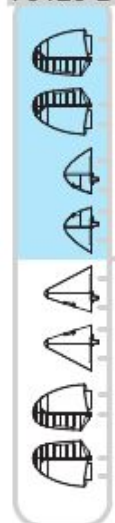

F>

70120 F

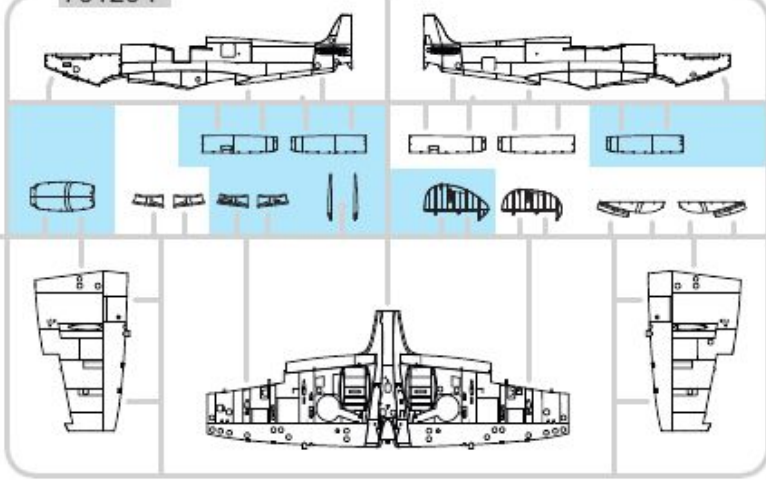

E>

70120 E

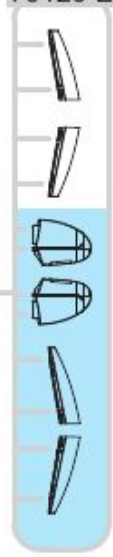
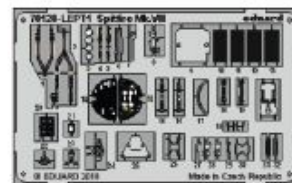
eduard
MASKPE - PHOTO ETCHED
DETAIL PARTS

-Parts not for use. -Teile werden nicht verwendet. -Pièces à ne pas utiliser. -Tyto díly nepoužívejte při stavbě. - 使用しない部品

COLOURS



BARVY



FARBEN



PEINTURE



色

GSI Creos (GUNZE)		MISSION MODELS	
AQUEOUS	Mr.COLOR	PAINTS	
H4	C4	MMP-007	YELLOW
H12	C33	MMP-047	FLAT BLACK
H13	C3	MMP-003	FLAT RED
H33	C81		RUSSET
H51	C11	MMP-063	LIGHT GULL GRAY
H71	C21	MMP-076	MIDDLE STONE
H72	C22	MMP-078	DARK EARTH
H77	C137	MMP-040	TIRE BLACK
H90	C47		CLEAR RED
H94	C138		CLEAR GREEN

GSI Creos (GUNZE)		MISSION MODELS	
AQUEOUS	Mr.COLOR	PAINTS	
H330	C361	MMP-077	DARK GREEN
H335	C363	MMP-094	MEDIUM SEAGRAY
	C362	MMP-093	OCEAN GRAY
	C364	MMP-079	AIRCRAFT GRAY-GREEN
	C370	MMP-092	AZURE BLUE
Mr.METAL COLOR		METALLICS	
MC214		MMM-001	DARK IRON
MC218		MMM-003	ALUMINIUM
Mr.COLOR SUPER METALLIC		METALLICS	
SM01		MMC-001	SUPER CHROME

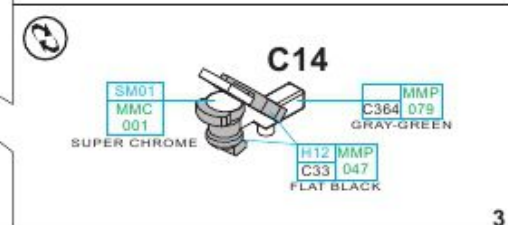
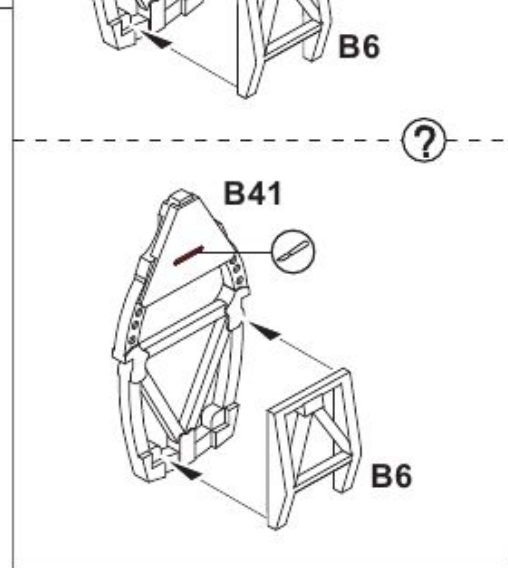
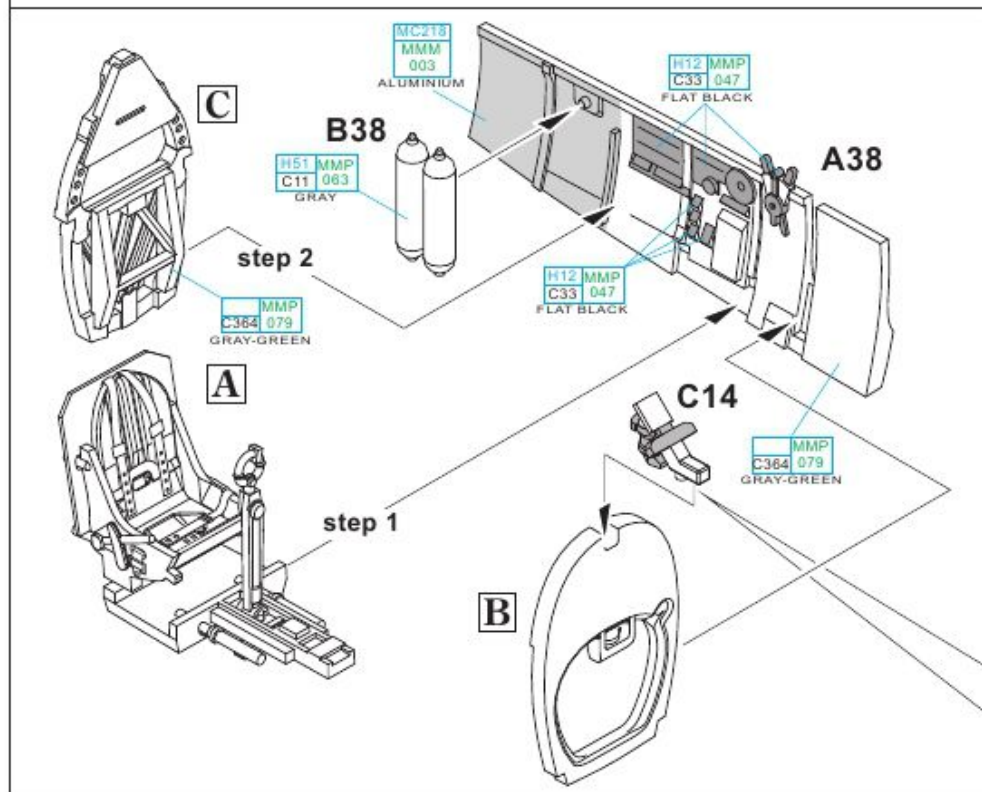
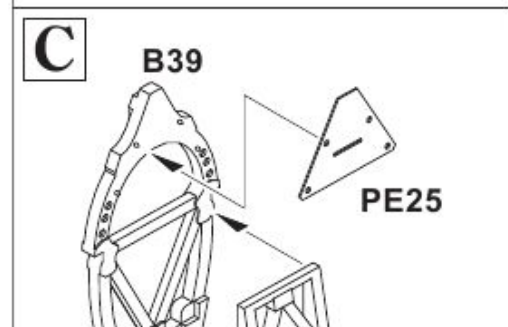
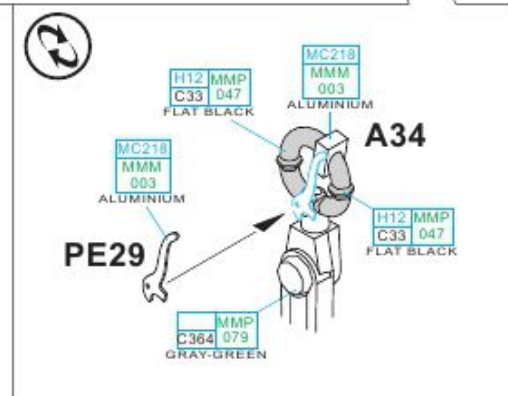
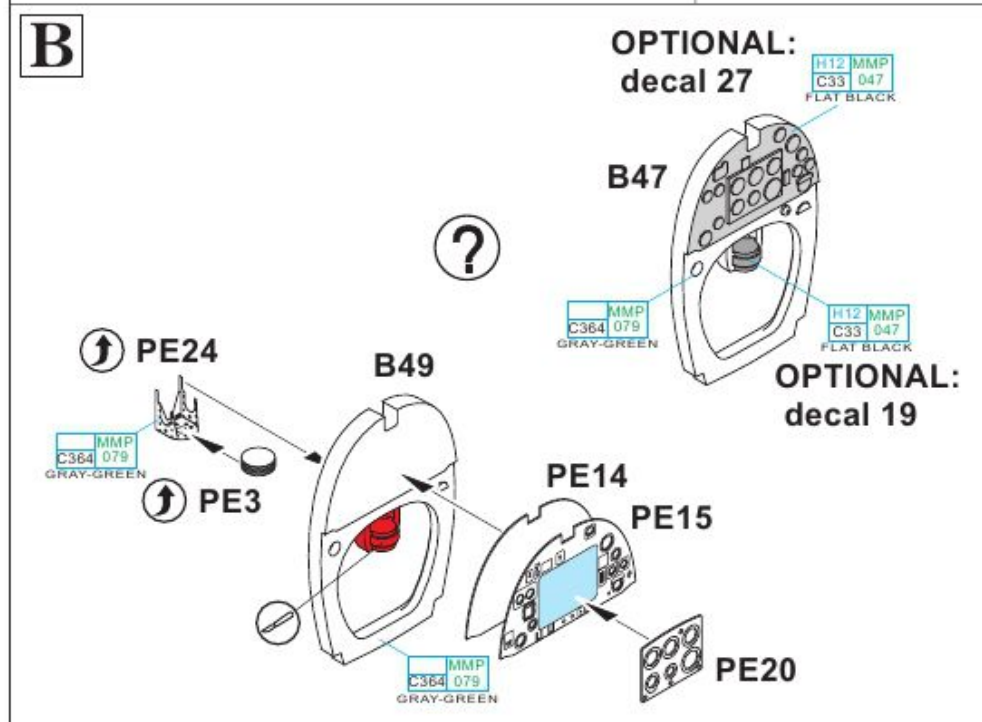
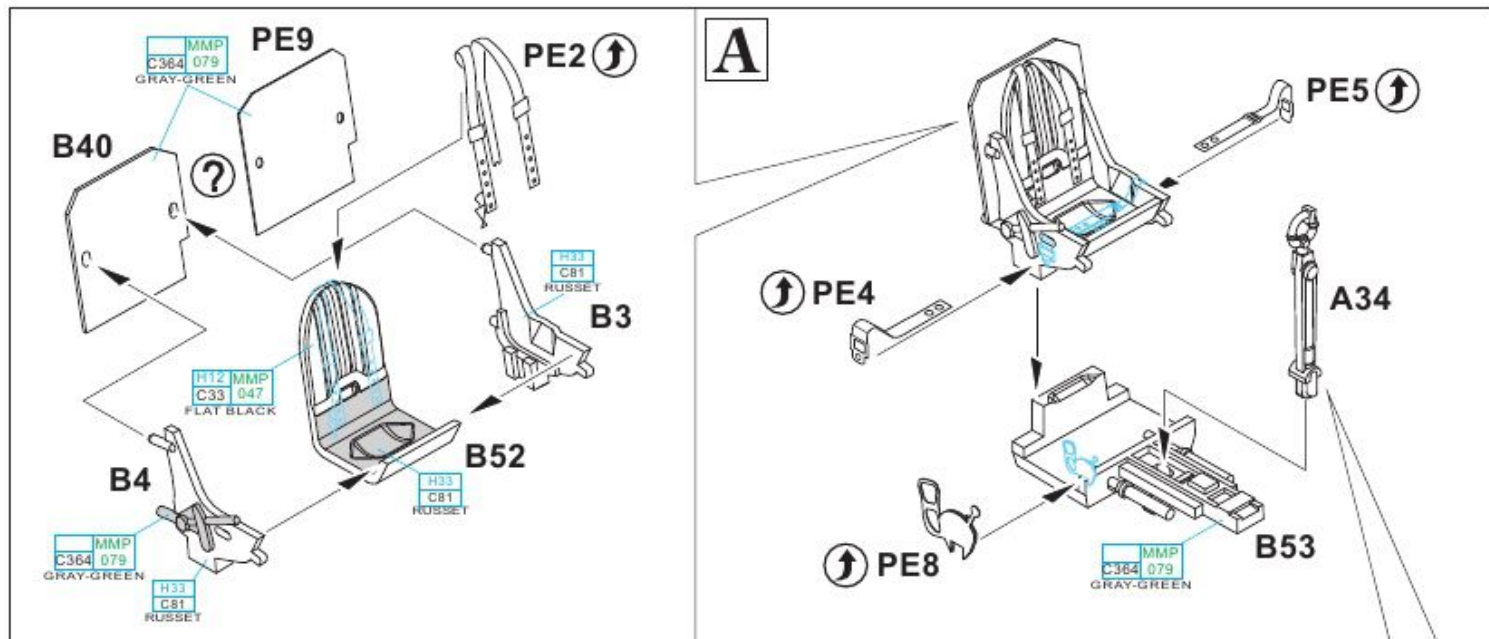

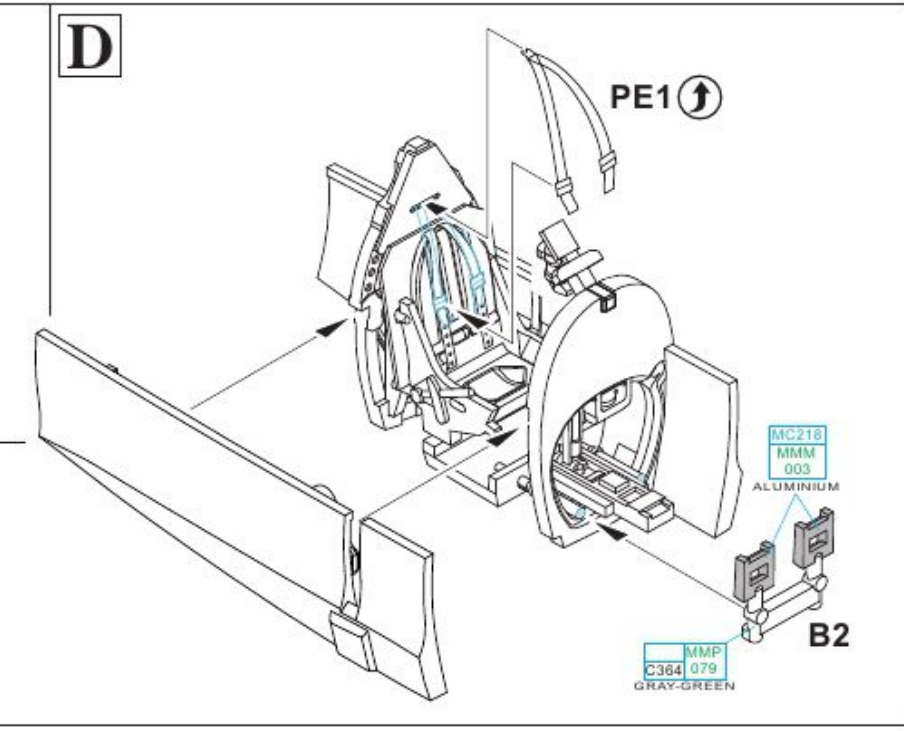
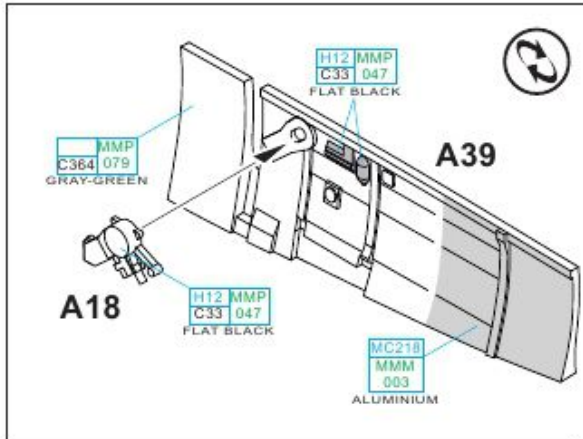

? FOR CLOSED CANOPY ONLY

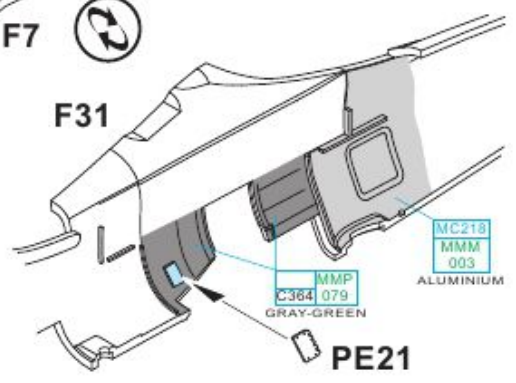
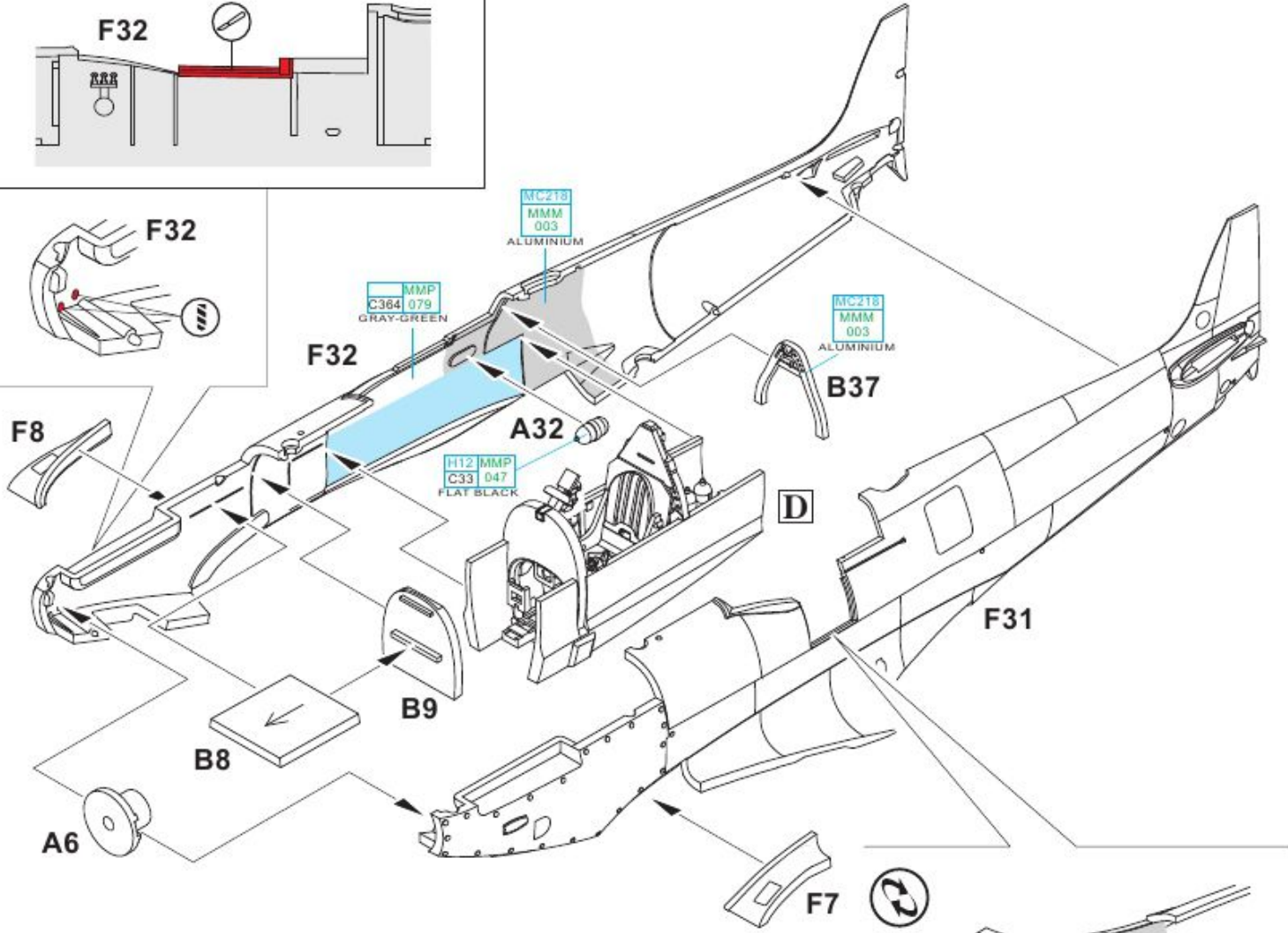
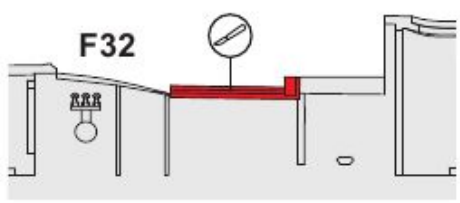
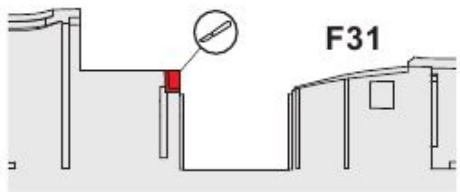

H90 C47	H94 C138	- MARKINGS A, B, D, E
CLEAR RED, CLEAR GREEN		
SM01 MMC 001		- MARKING C
SUPER CHROME		

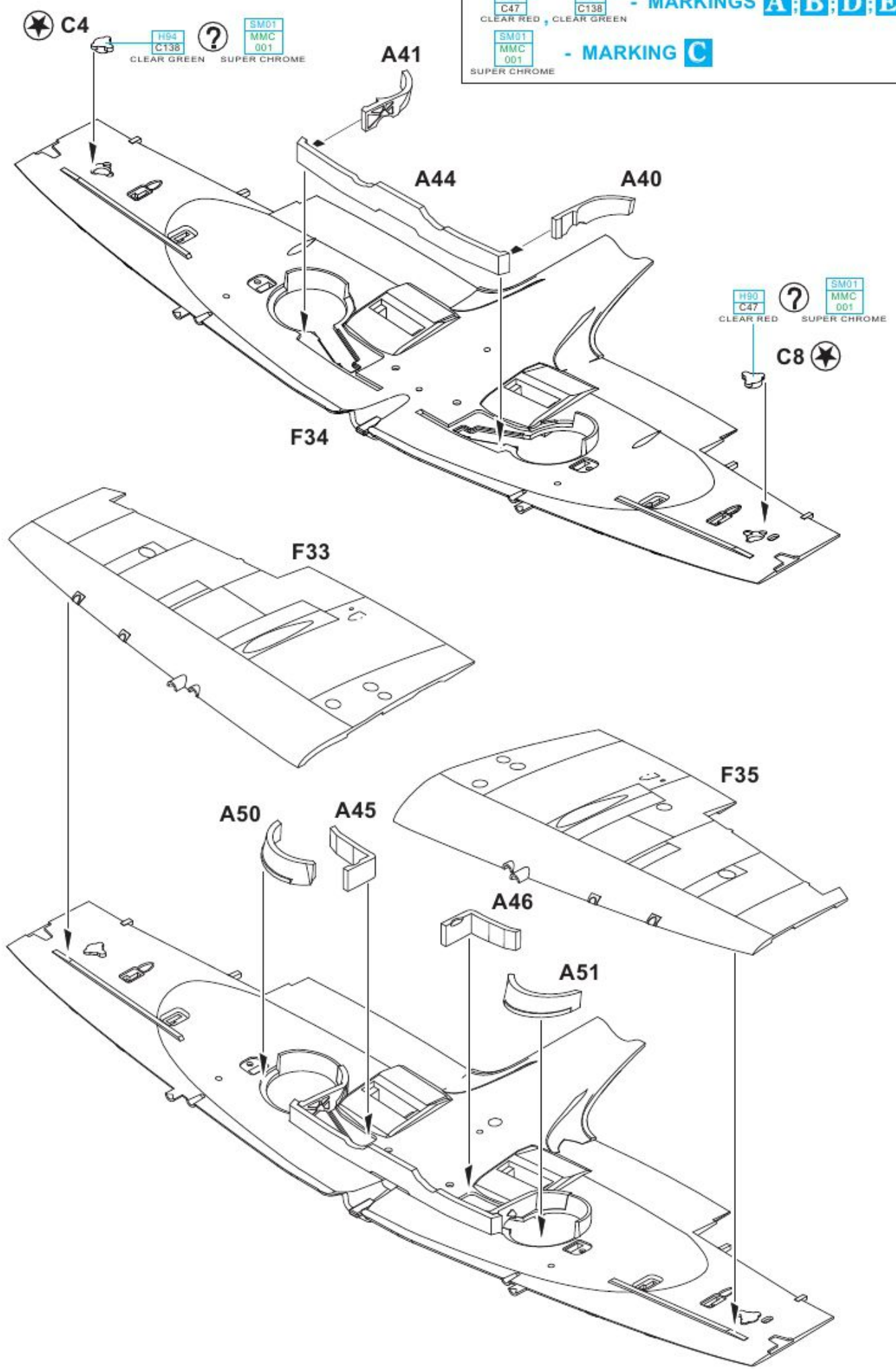

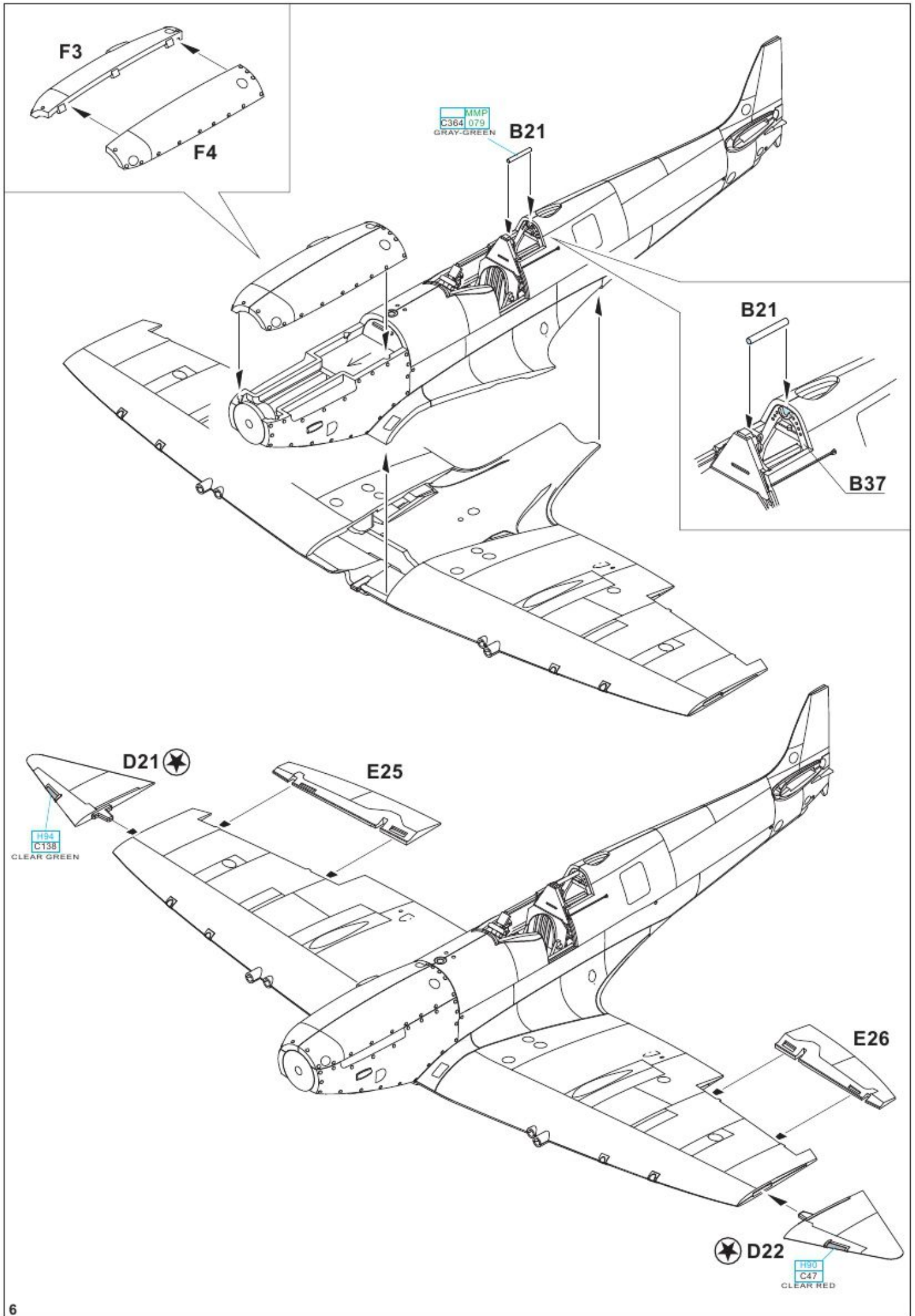

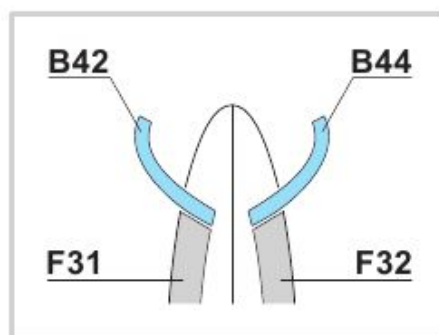
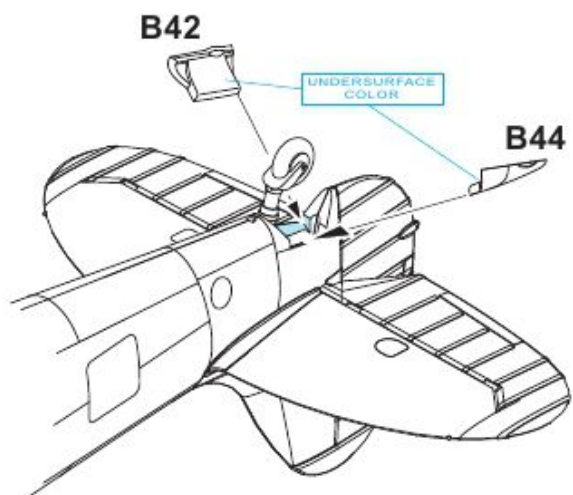
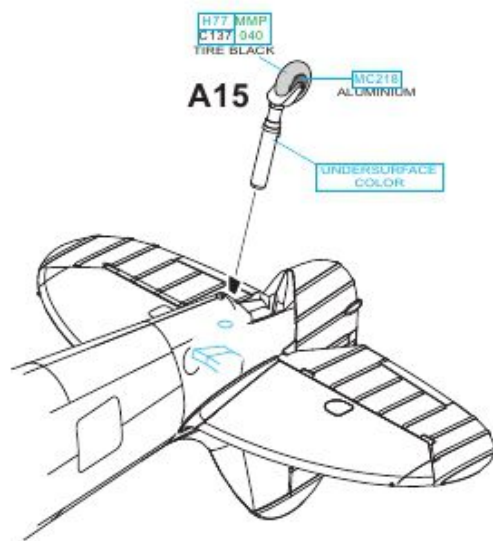
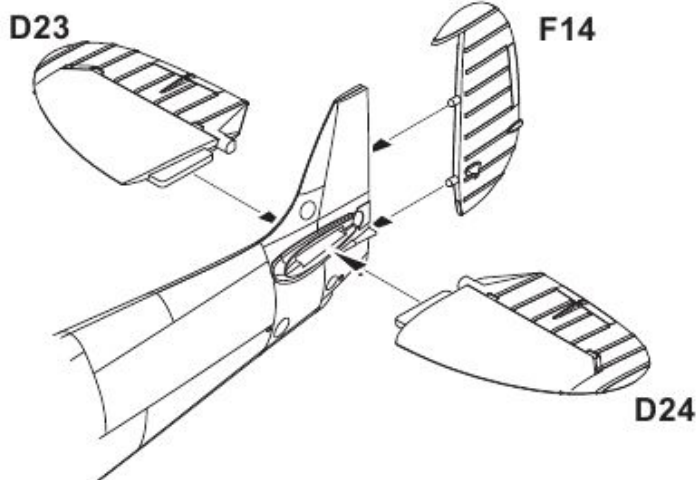

E

PE31, PE32 - MARKINGS
A, B, D, E ONLY

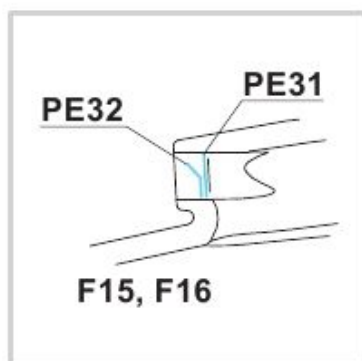
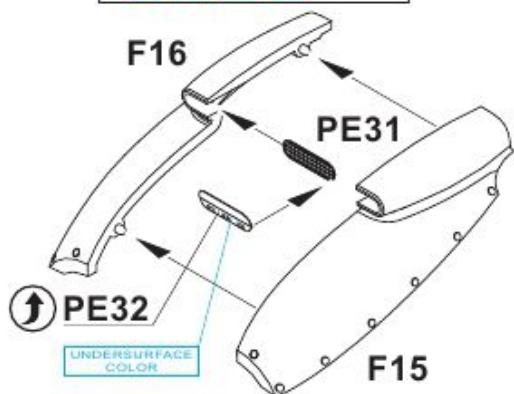

F

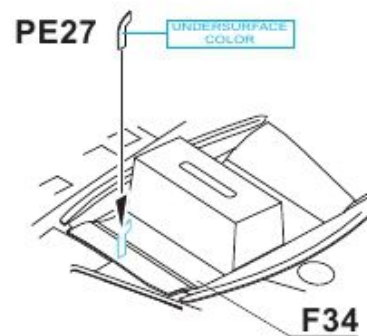

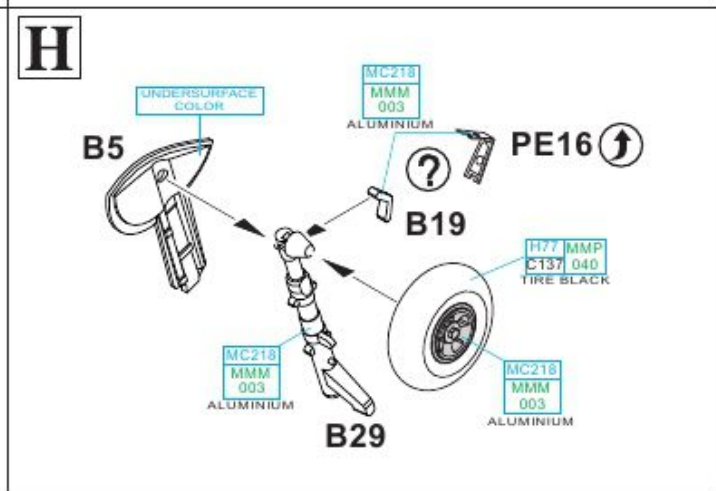
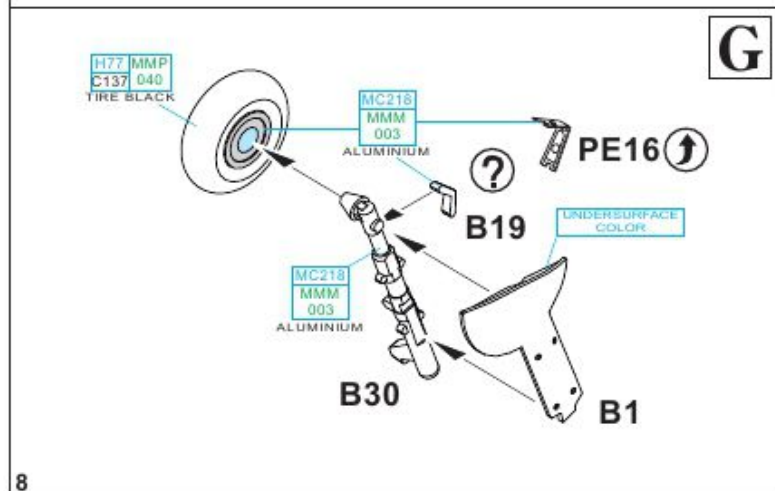
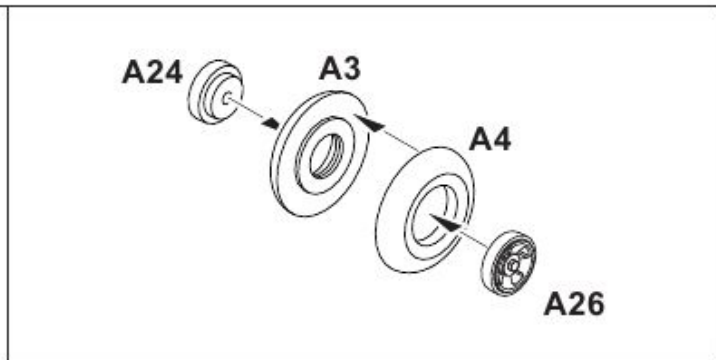
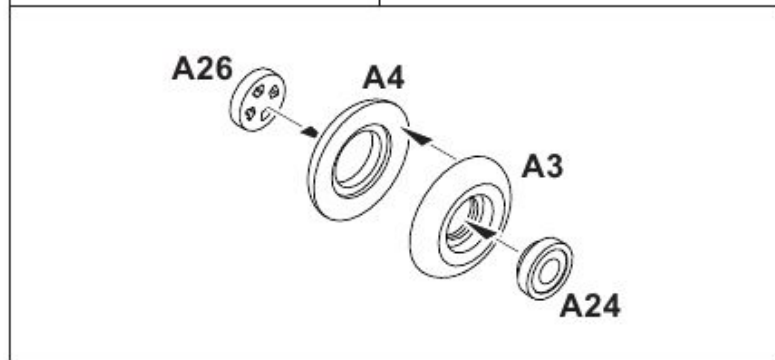
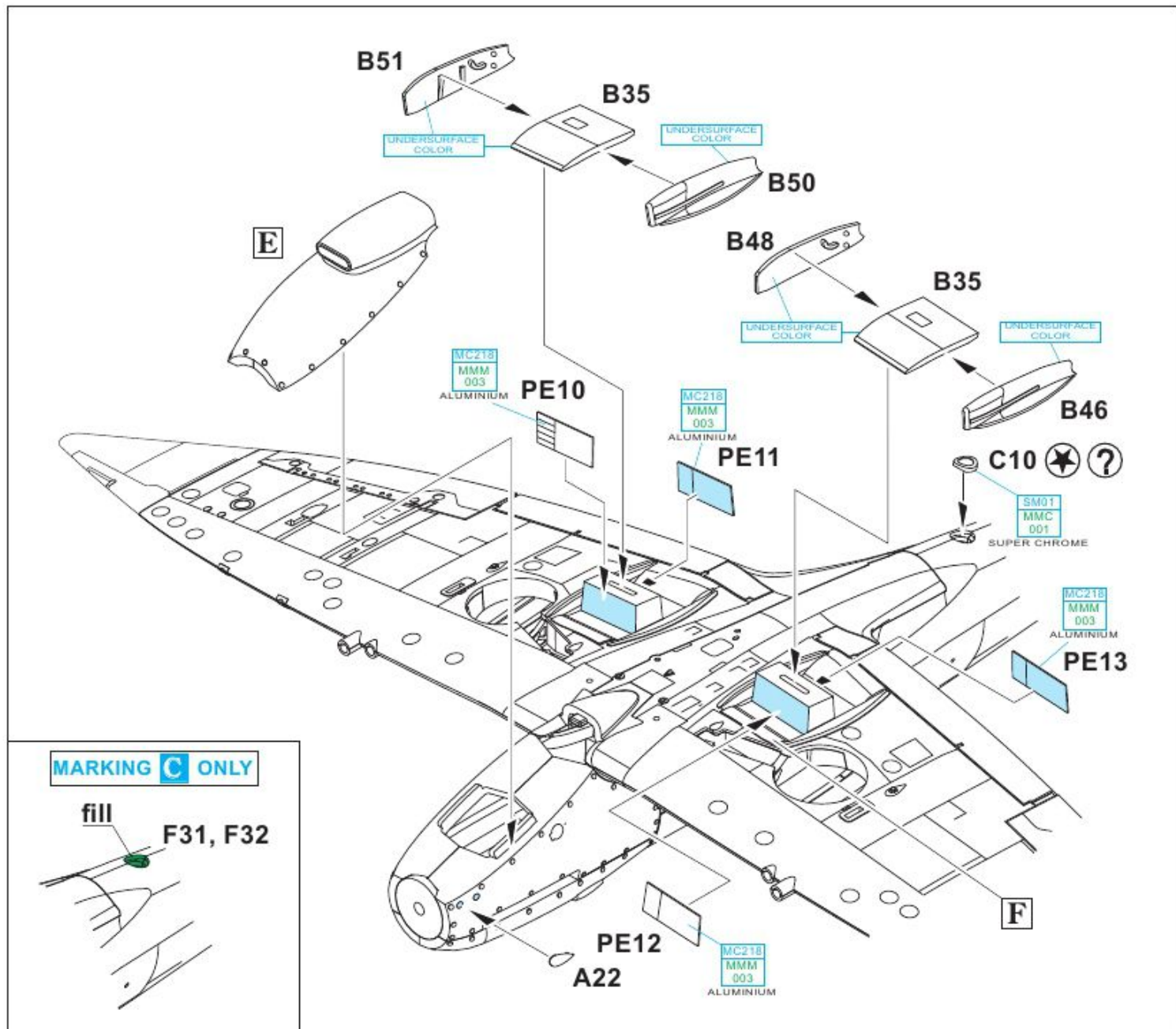

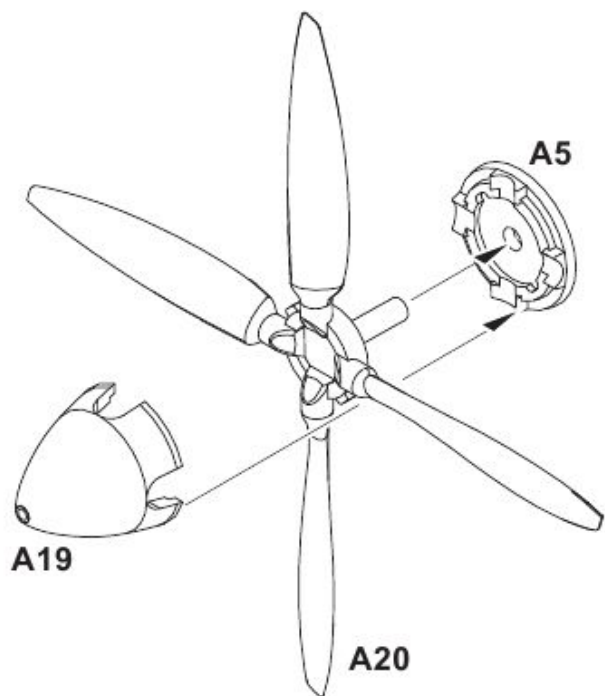
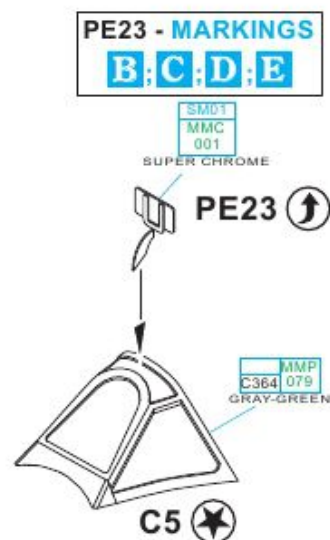
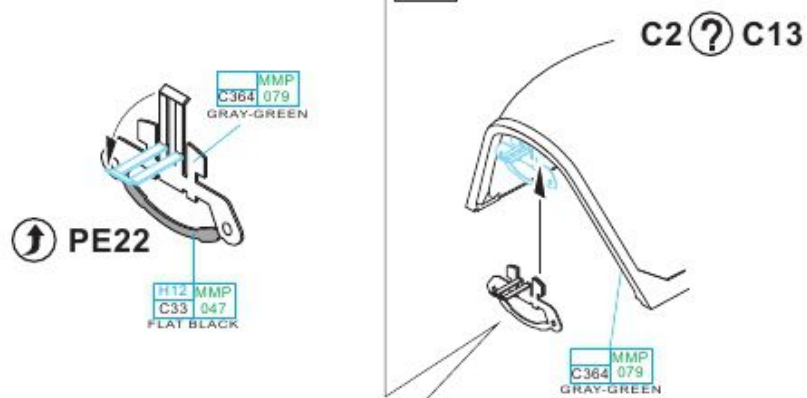
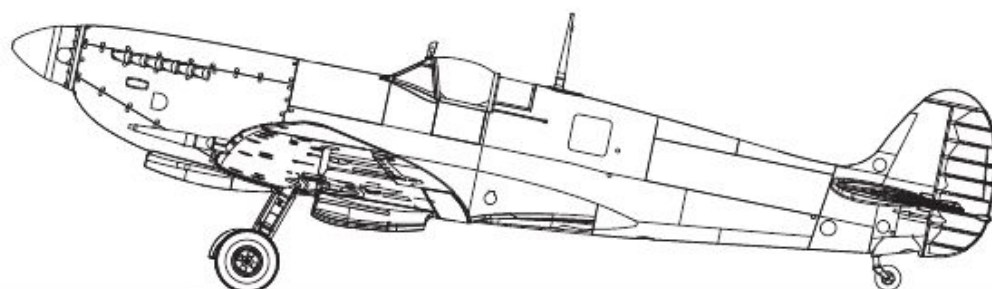
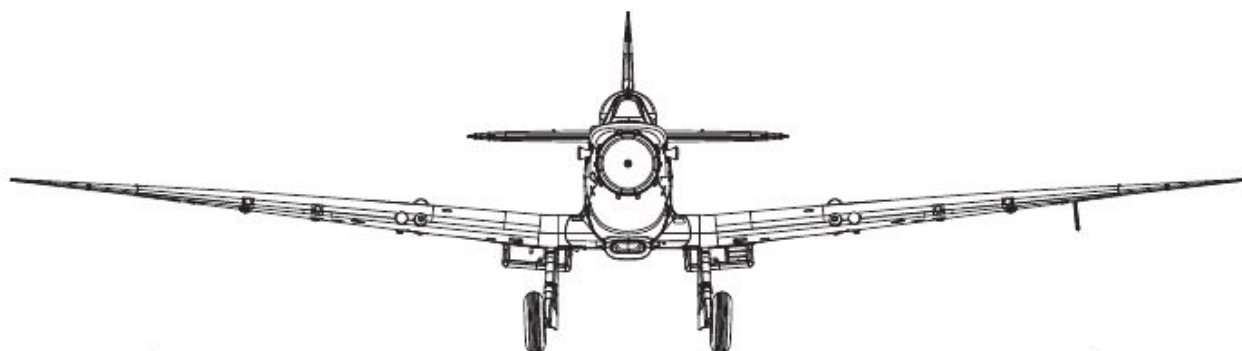
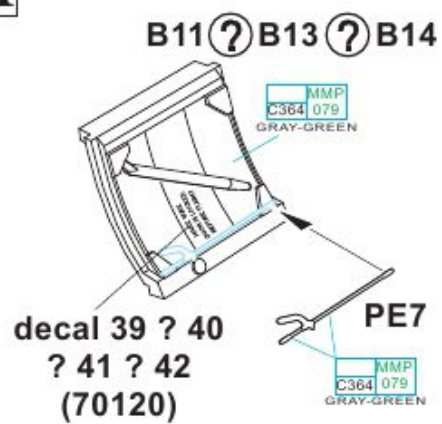
J**K****L****M**

B11 - closed canopy & closed door

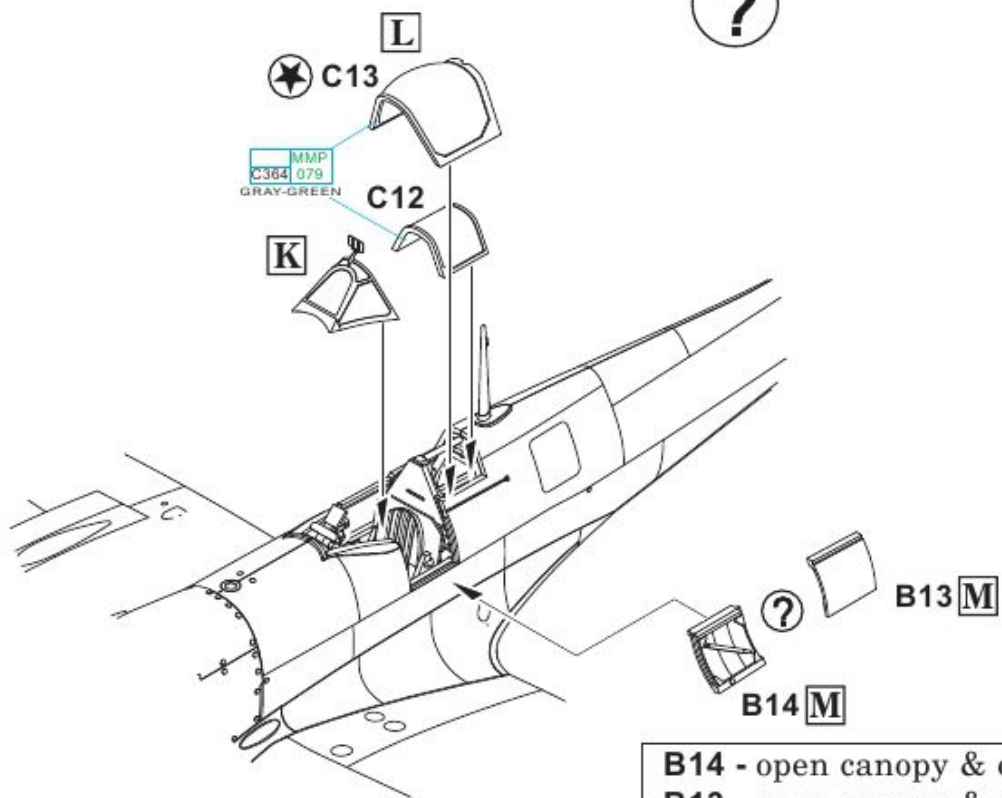
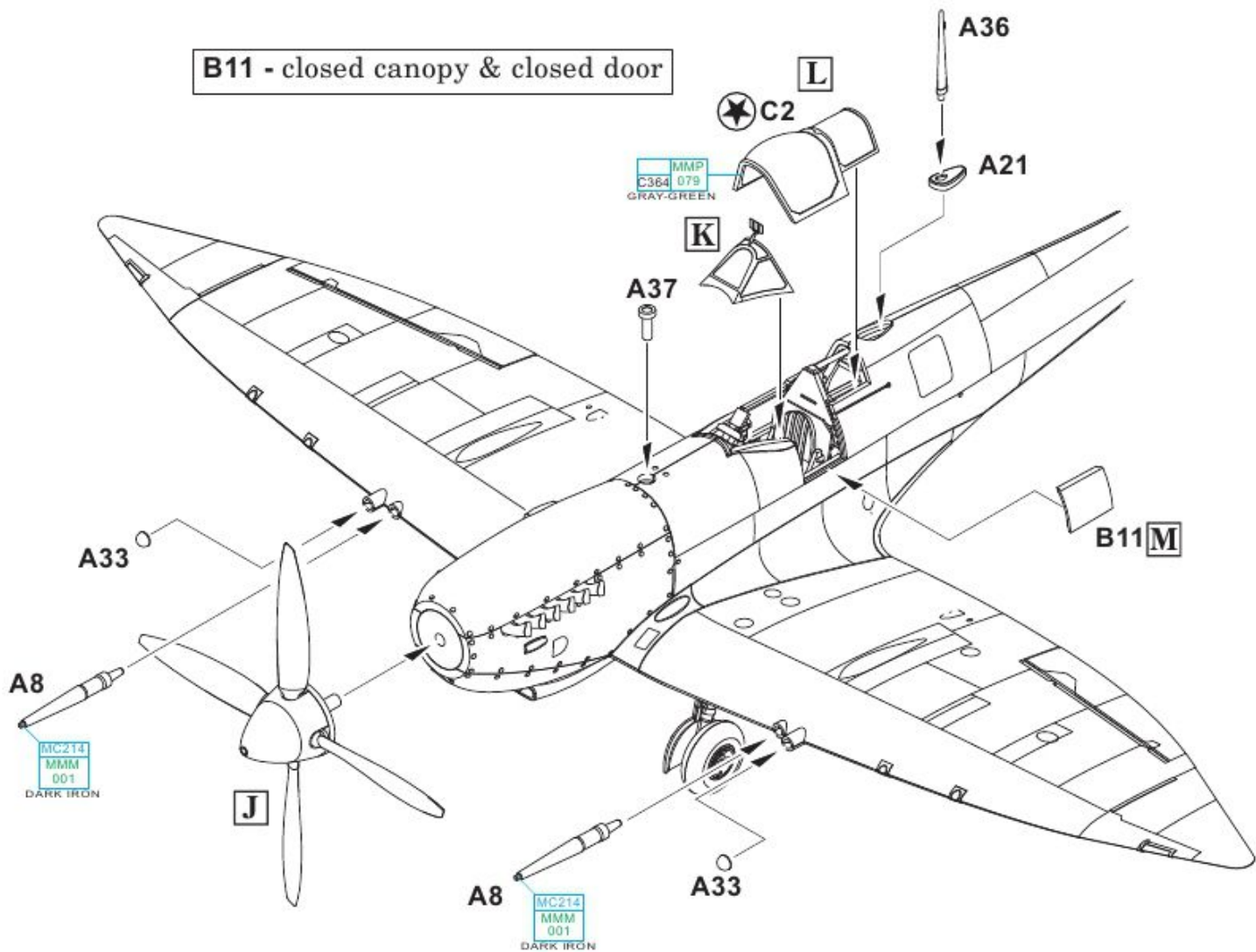

B14 - open canopy & open door
B13 - open canopy & closed door

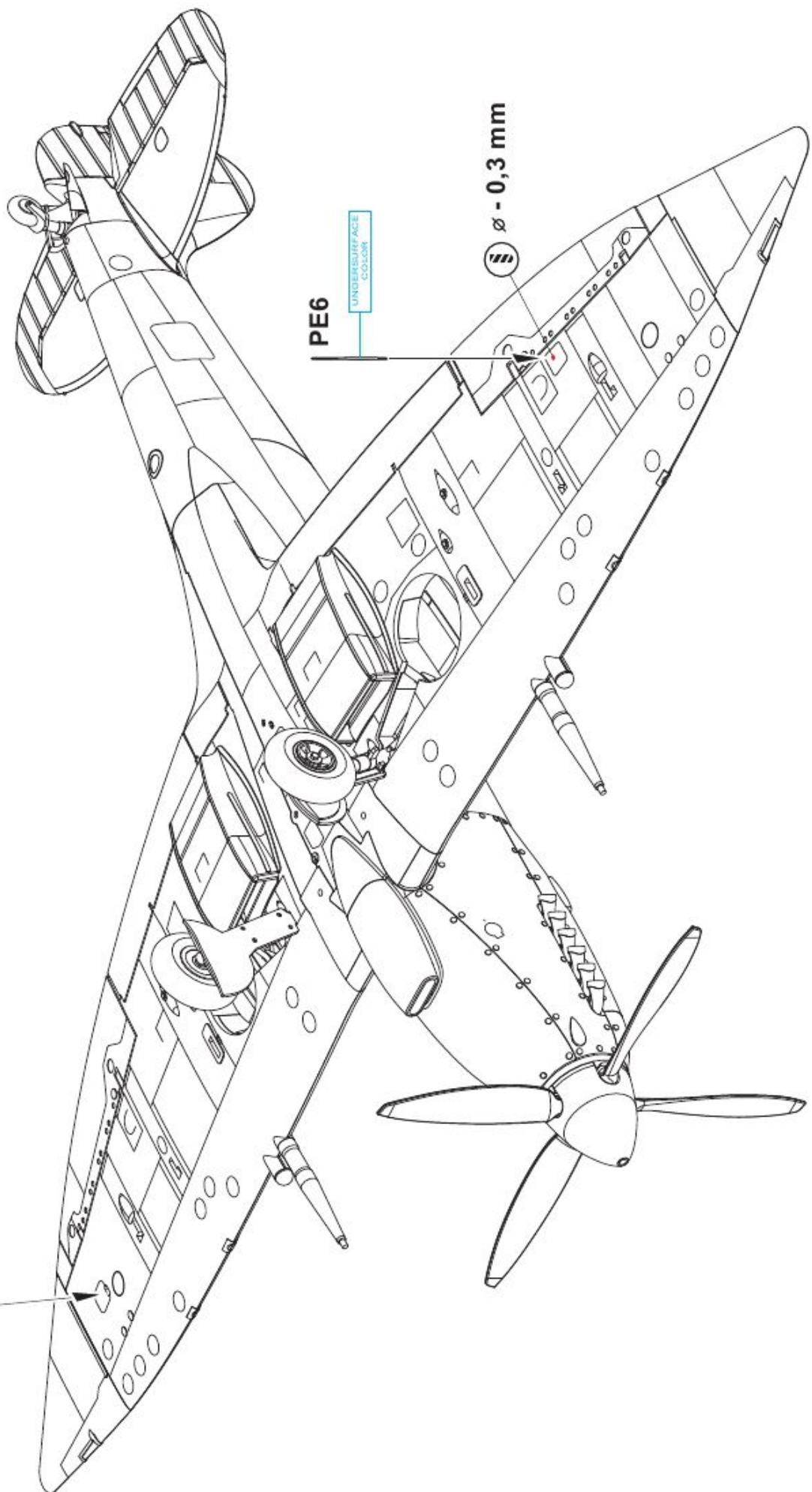

PE6

UNDERSURFACE
COLOR

∅ - 0,3 mm

A31
ALUMINIUM

UNDERSURFACE
COLOR

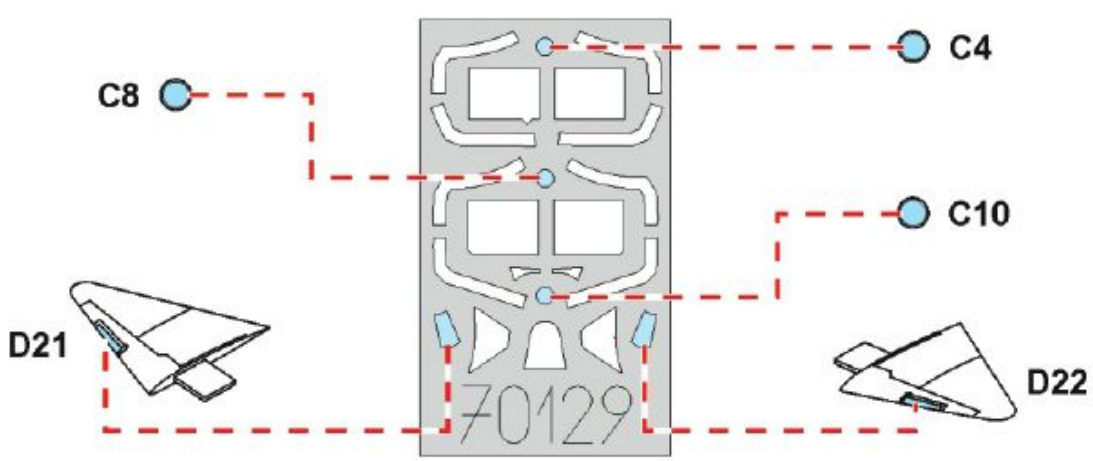
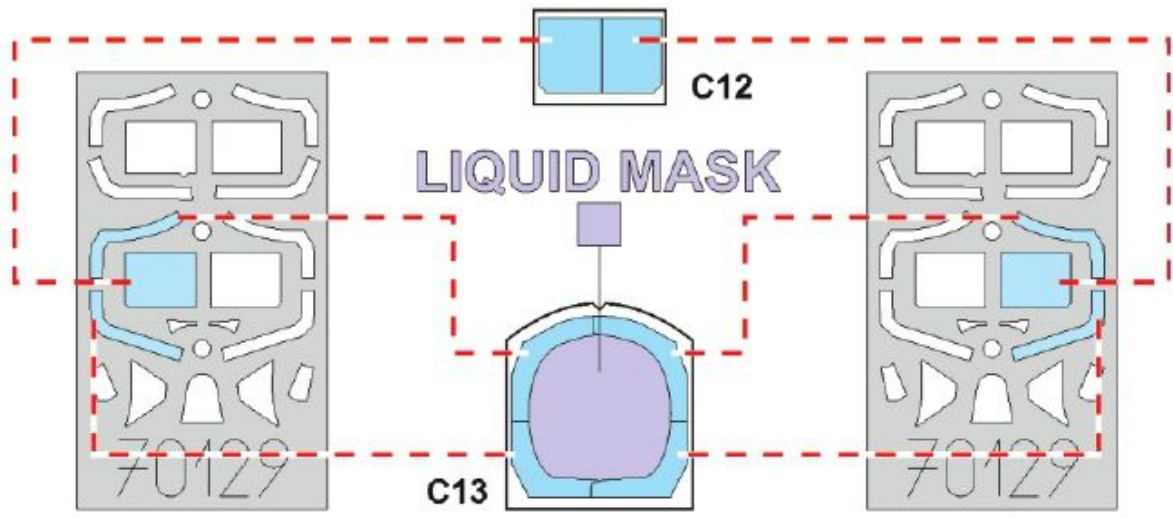
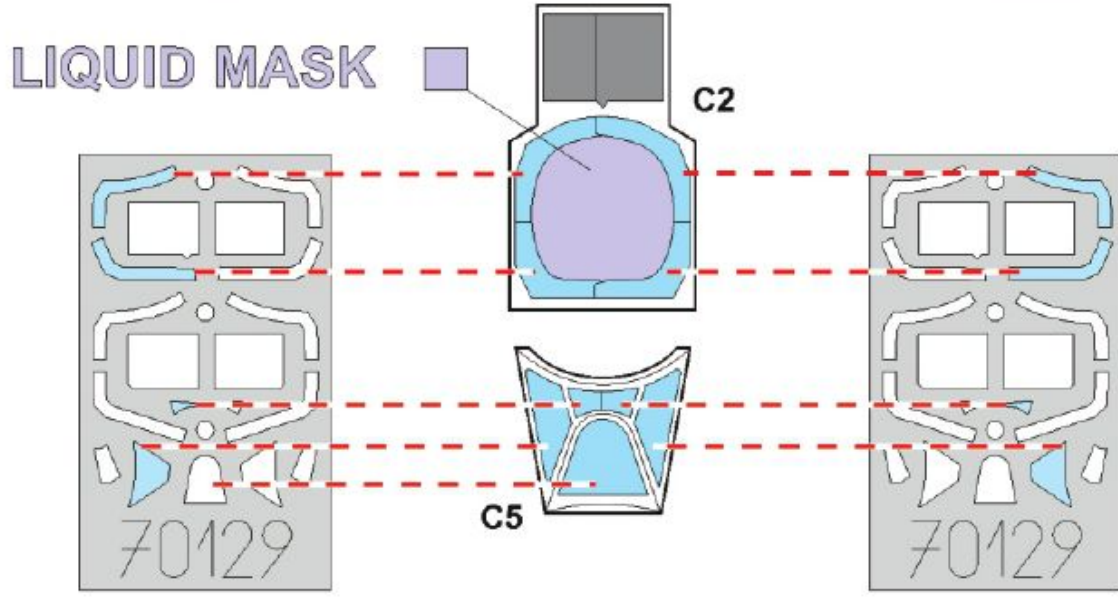
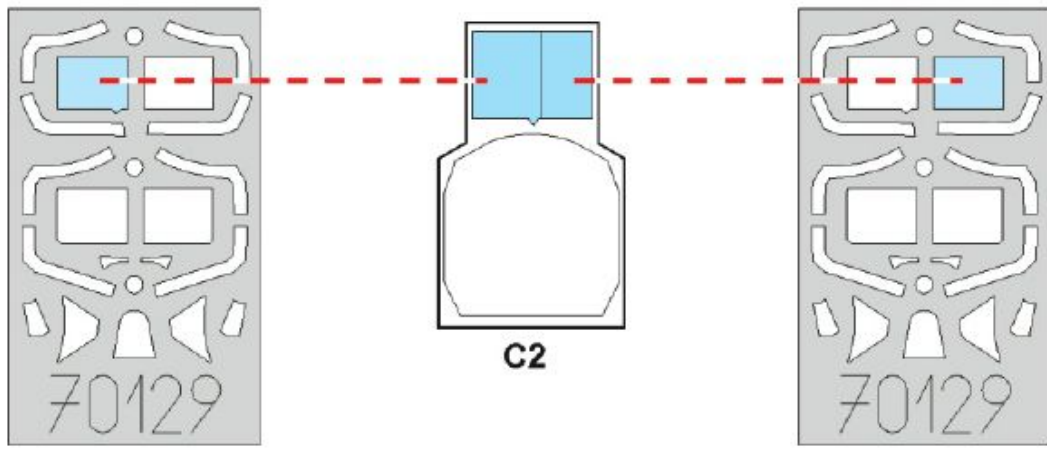

A JF476, No. 92 Squadron, Triolo, Sicily, November 1943

Originally No. 92 Fighter Squadron fighting in WWI was cancelled in August 1919. On October 10th, 1939 a squadron bearing the same number was established. It was first equipped with Bristol Blenheims. Right at the beginning of year 1940 it got Spitfires, which were fighting above Dunkerque and also fought in the Battle of Britain. In February 1942 the squadron was sent to Africa where it served against German and Italian armed forces. After the fights in Africa terminated, the squadron fought above Malta and Sicily, later the squadron served above Italy. The squadron was disbanded on December 30th, 1946 in Austrian Zeltweg. During WWII it reached the highest number of shot downs of the enemy aircraft among the RAF Wings, 317 victories over the enemy aircraft. No. 92 Squadron aircraft had a Desert Scheme Camouflage. This consisted of Dark Earth and Middle Stone colours on the top surfaces, the undersides were painted in Azure Blue colour. The colour of the letters of coding of the squadron could not be clearly determined, various sources state blue and red. Both sides of the fuselage bore Desert Air Force sign.

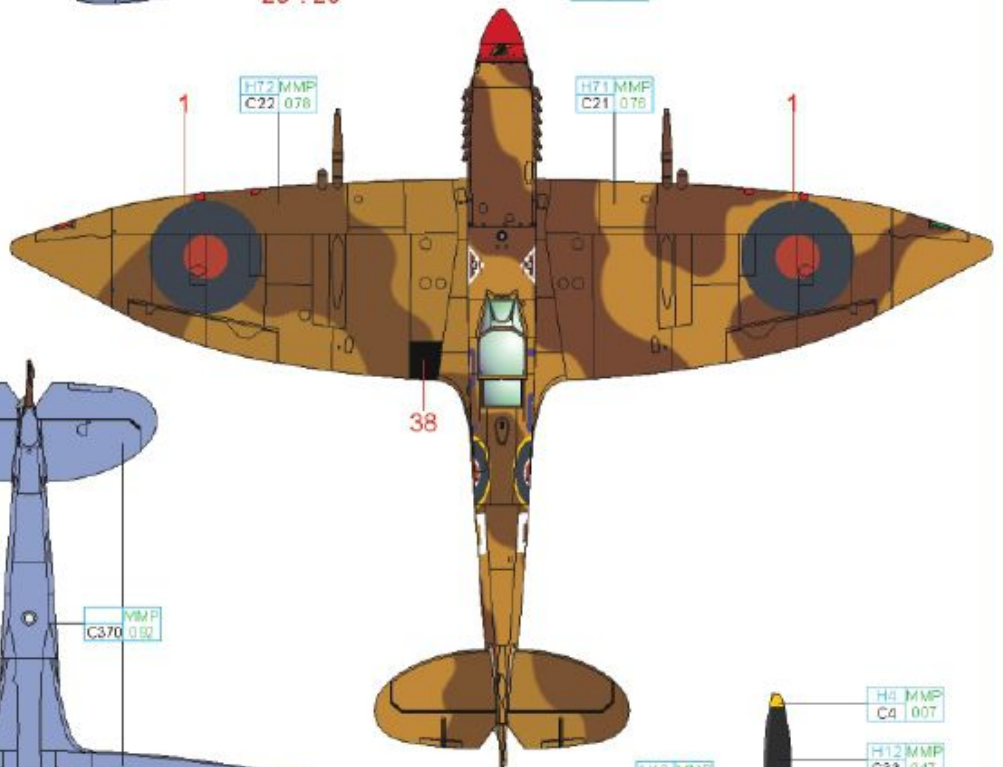
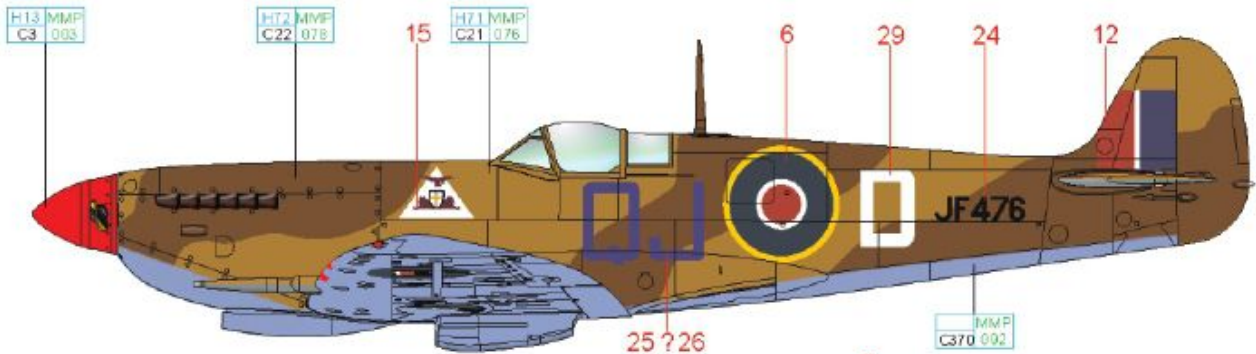

ČESKOU VERZI TEXTU NALEZNETE NA
www.eduard.cz
 POD KATALOGOVÝM ČÍSLEM 70129

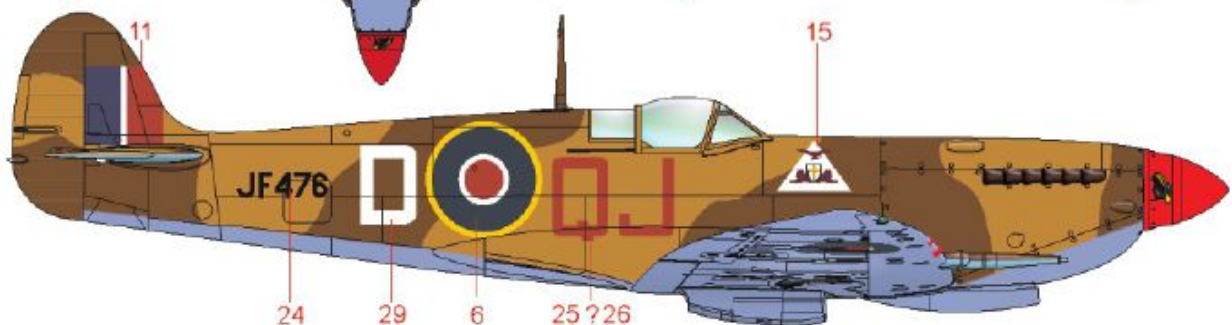
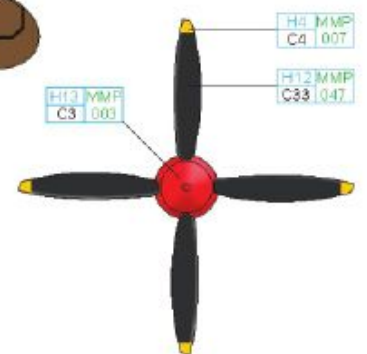
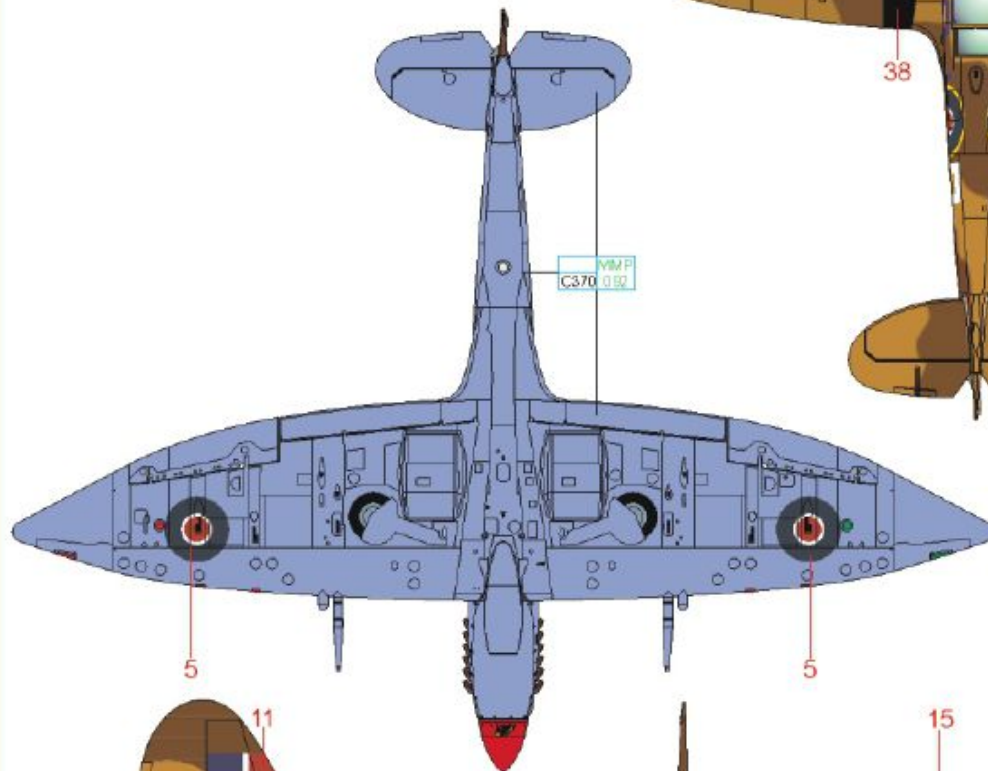

RED	H13 MMP C3 003	LIGHT YELLOW	H4 MMP C4 007
AZURE	MMP C370 092	MIDDLE STONE	H71 MMP C21 076
		DARK EARTH	H72 MMP C22 078
		BLACK	H12 MMP C33 047

B JF519, No. 1 Squadron SAAF, Trigno, Italy, February 1944

No. 1 Squadron SAAF was established in February 1940 by renaming of the No. 6 Squadron SAAF armed with Hawker Hurricane and Fury aircraft. In the mid of the year 1940 the pilots of this unit joined the fights above North Africa. At the turn of 1942 and 1943 the squadron received Spitfires and flew them in the fights under the African sun. These fights were followed by the use of these aircraft above Malta and Sicily. The wartime presence of the squadron finished in Italy. After WWII, the squadron remained active, first with Spitfires, Vampire, Sabre and Impala and then, in April 1975, the squadron was rearmed with French Mirage F.1. The squadron was disbanded on November 25th, 1997 at the Hoedspruit Base. The Mk.VIII Spitfires used by No. 1 Squadron SAAF above Italy had a Day Fighter Camouflage Scheme. The upper surfaces were painted in Ocean Grey and Dark Green; the undersides with Medium Sea Grey colour. The wing tips of Spitfires of this squadron were painted red.

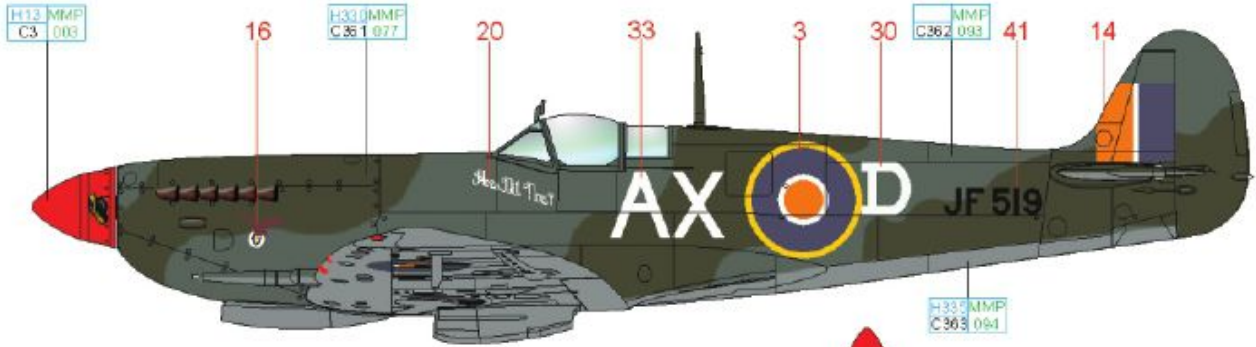

ČESKOU VERZI TEXTU NALEZNETE NA
www.eduard.cz
POD KATALOGOVÝM ČÍSLEM 70129

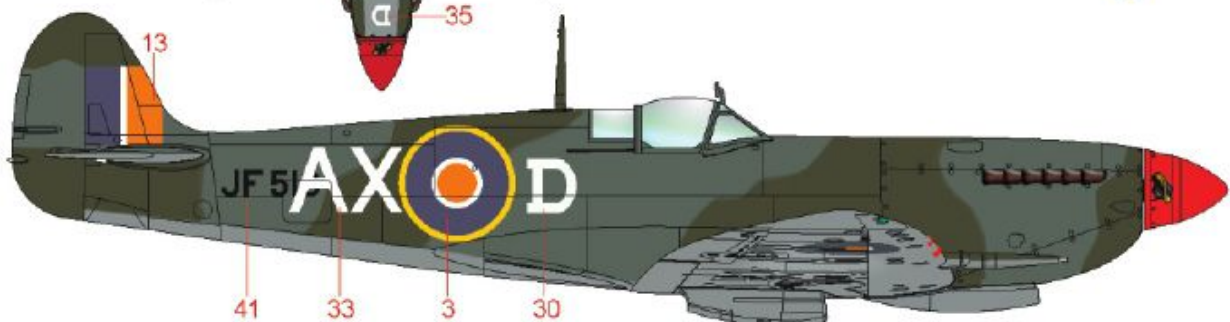
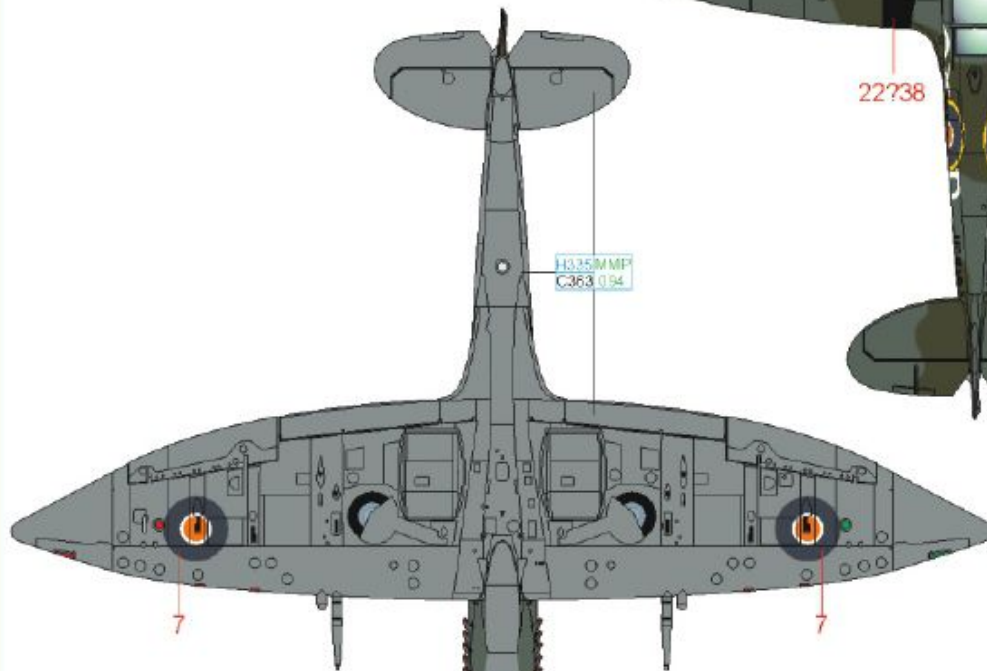
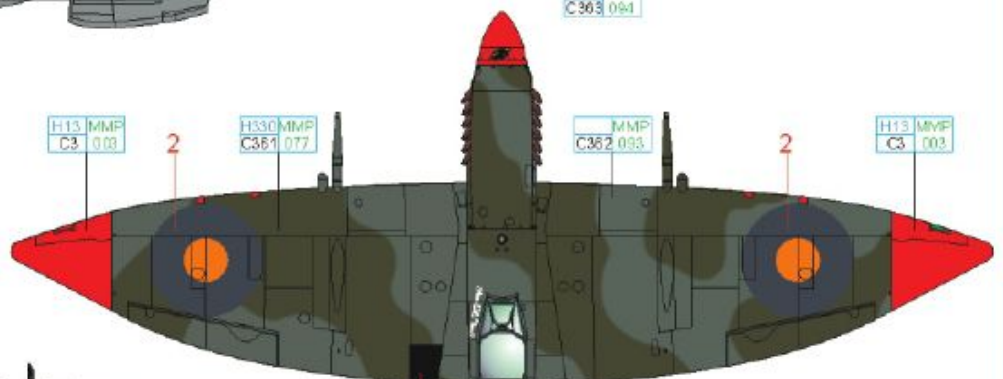

RED	H13 MMP C3 003	LIGHT YELLOW	H4 MMP C4 007
MEDIUM SEA GRAY	H335 MMP C363 094	OCEAN GRAY	MMP C362 093
		DARK GREEN	H330 MMP C361 077
		BLACK	H12 MMP C33 047

C JF630, flown by F/O L. Cronin, No. 81 Squadron, Palel, India, March 1944

According to the interview with Larry Cronin the squadron A/C retained their desert colours. The pilot maintains that his aircraft still had its extended wingtips when he gained his victories. In November 1943, No. 81 Squadron, RAF, withdrew from Sicily to Egypt where they re-equipped with Spitfire Mk.VIII aircraft. Cronin recalls that all these aircraft were in the JF serial range and had extended wingtips and standard rudders. Photos of aircraft in this serial batch showing this configuration support his comments. Most sources state that the aircraft were re-camouflaged in Dark Earth, Dark Green and Sea Grey Medium when they arrived in India. The comments in those sources appear to be based on an order issued by RAF Headquarters, New Delhi. The date of the order is April 4th, 1944, some three months after No.81 Squadron's arrival in the theatre, and a month after the only known photos of Cronin's aircraft were taken.

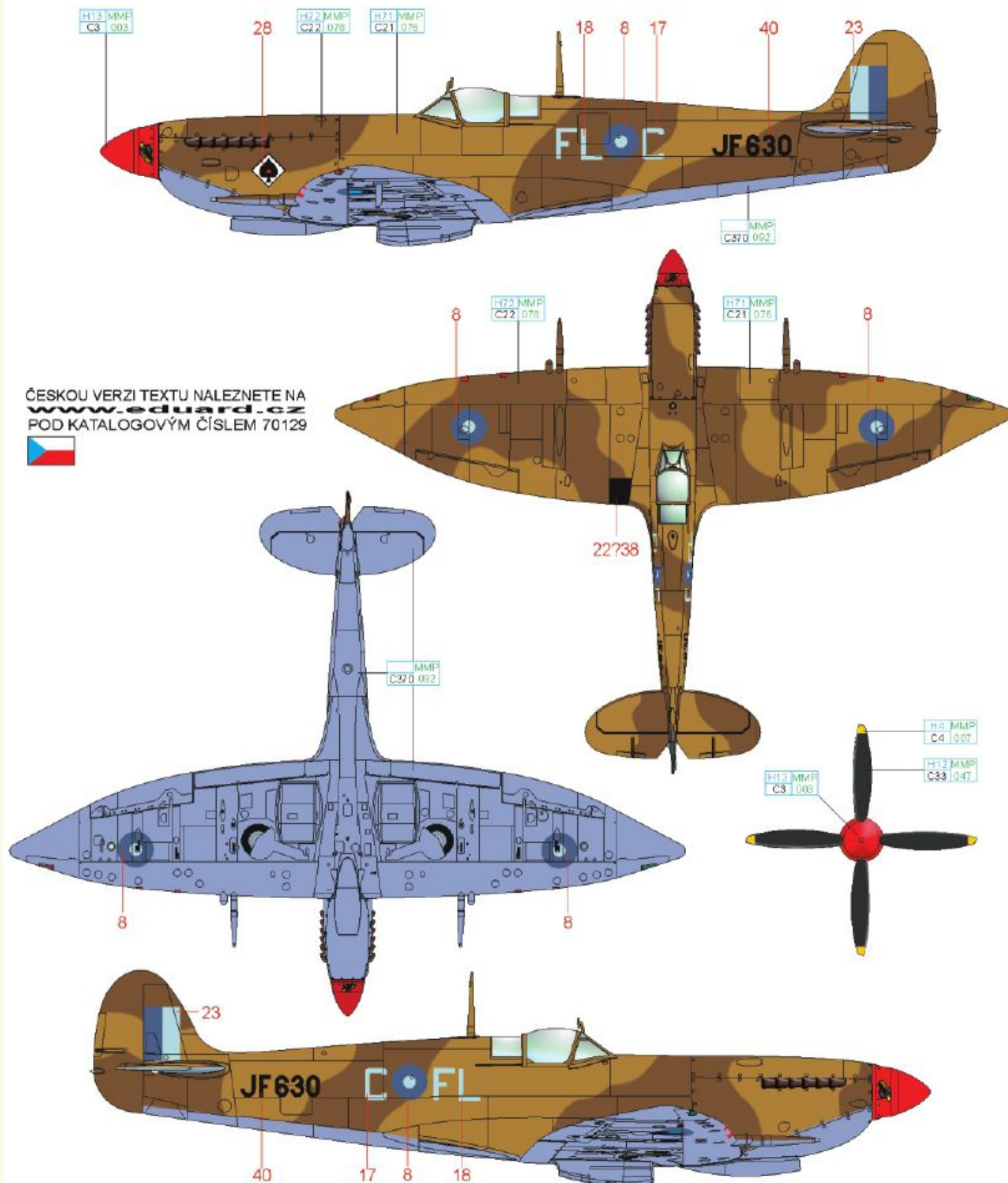

ČESKOU VERZI TEXTU NALEZNETE NA
www.eduard.cz
 POD KATALOGOVÝM ČÍSLEM 70129



RED	H13 MMP C3 003	LIGHT YELLOW	H4 MMP C4 007
AZURE	MMP C370 092	MIDDLE STONE	H71 MMP C21 076
		DARK EARTH	H72 MMP C22 078
		BLACK	H12 MMP C33 047

eduard

D JF404, No. 32 Squadron, Foggia, Italy, early 1944

The high altitude fighter camouflage scheme adorned this Spitfire as well. In accordance with regulations, red-blue cockades were painted on the fuselage and upper sides of the wings. No national insignia was applied on the bottom of the wings. A photo of this aircraft shows that the GZ code letters did not adhere to regulations on the right side of the fuselage.

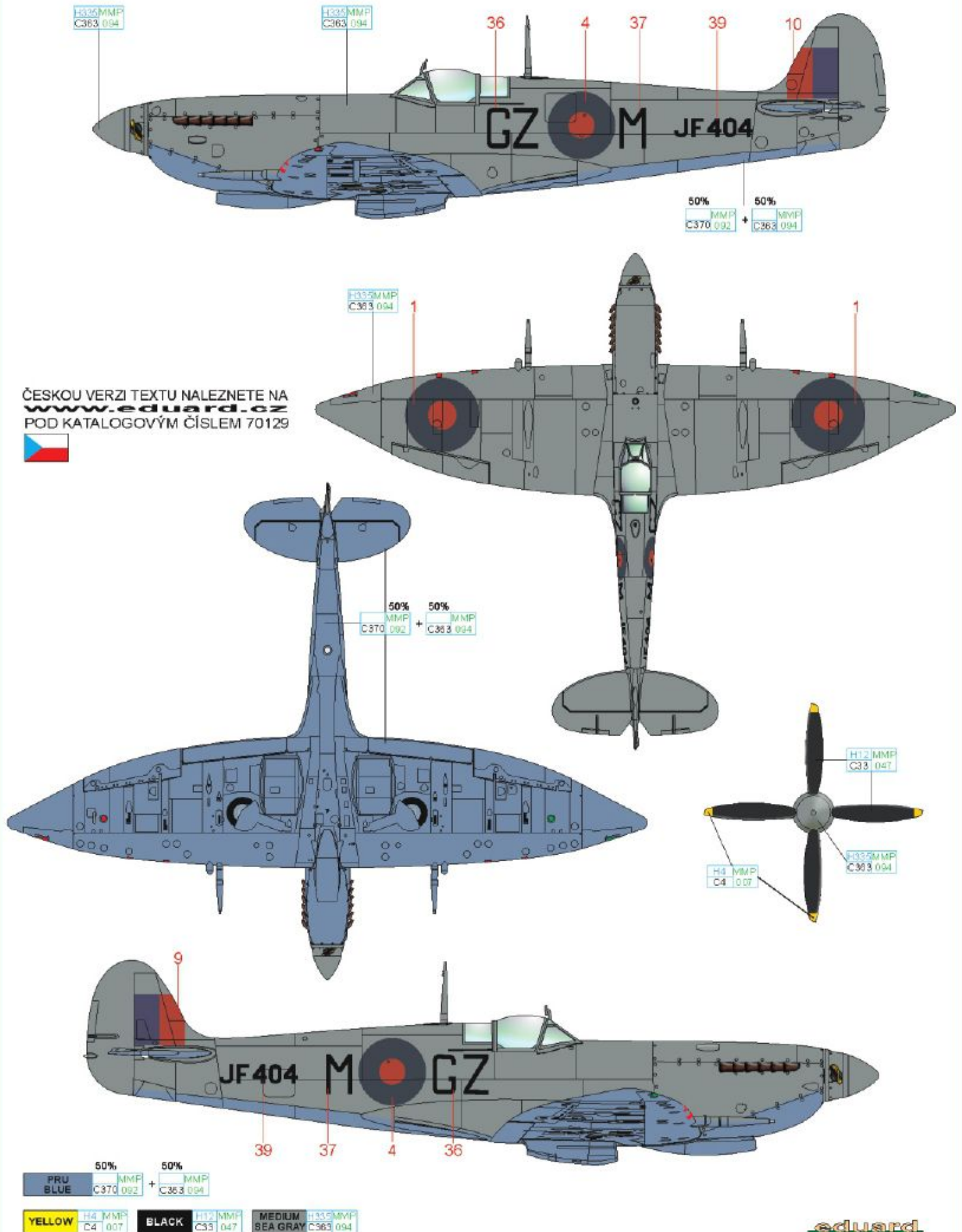

E 308th Fighter Squadron, 31st Fighter Group, Castel Volturno, Italy, 1944

308th Fighter Squadron was armed with P-39s and P-40s. The performance of these fighters was not enough to keep up with German opponents, which led to a relatively quick rearmament to Spitfires Mk.V. The Spitfires were used by 31st Fighter Group in a two-month heavy fights above northern France. Later the group was transferred to Gibraltar to use the base for take offs for Algeria as part of the disembarkation of the Allies in North Africa (Operation Torch). What followed were the fights against the forces of the Axis in North Africa. In May 1943 the 308th Fighter Squadron received Spitfires Mk.VIII, which were than used in the fights above Sicily and Italy. In March 1944, the Spitfires were replaced by P-51 Mustangs, which were used by 308th Fighter Squadron pilots till the end of war.

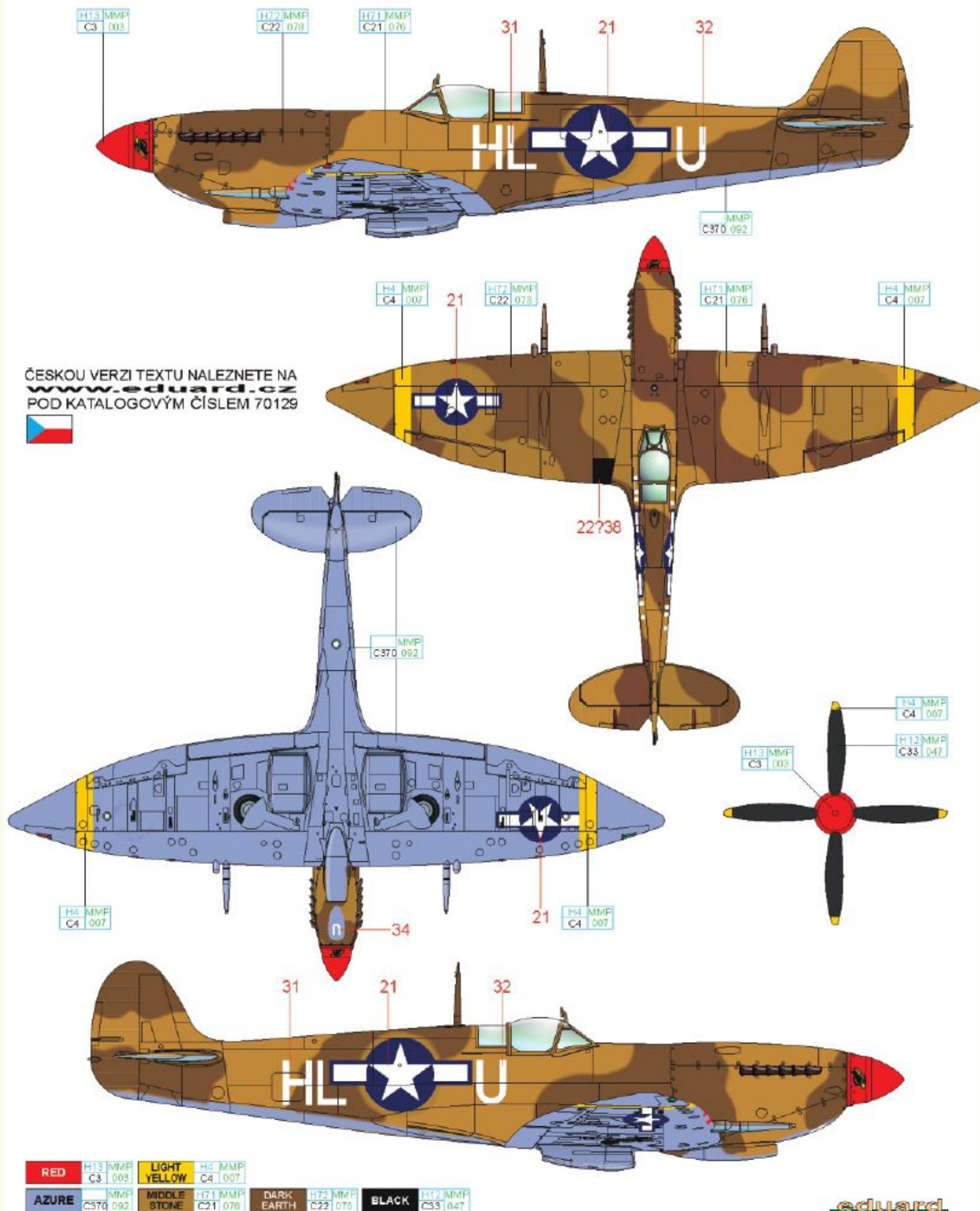

Spitfire HF Mk.VIII

1/48

#70129

ProfiPACK
edition

eduard

RELATED PRODUCTS:

- 72645 Spitfire Mk.VIII 1/72 Eduard (PE-Set)
- 72646 Spitfire Mk.VIII landing flaps 1/72 (PE-Set)
- 73036 Seatbelts RAF early STEEL 1/72 (PE-Set)
- 55581 Seatbelts RAF early STEEL 1/72 (PE-Set)
- +672146 Spitfire Mk.VIII wheels - 4 spoke w/ smooth tire 1/72 (Brassin)
- 672147 Spitfire Mk.VIII wheels - 4 spoke w/ pattern 1/72 (Brassin)
- 672154 Spitfire Mk.VIII gun bays 1/72 (Brassin)
- 672155 Spitfire Mk.VIII top cowl 1/72 (Brassin)
- 672156 Spitfire Mk.VIII cockpit 1/72 (Brassin)

672155

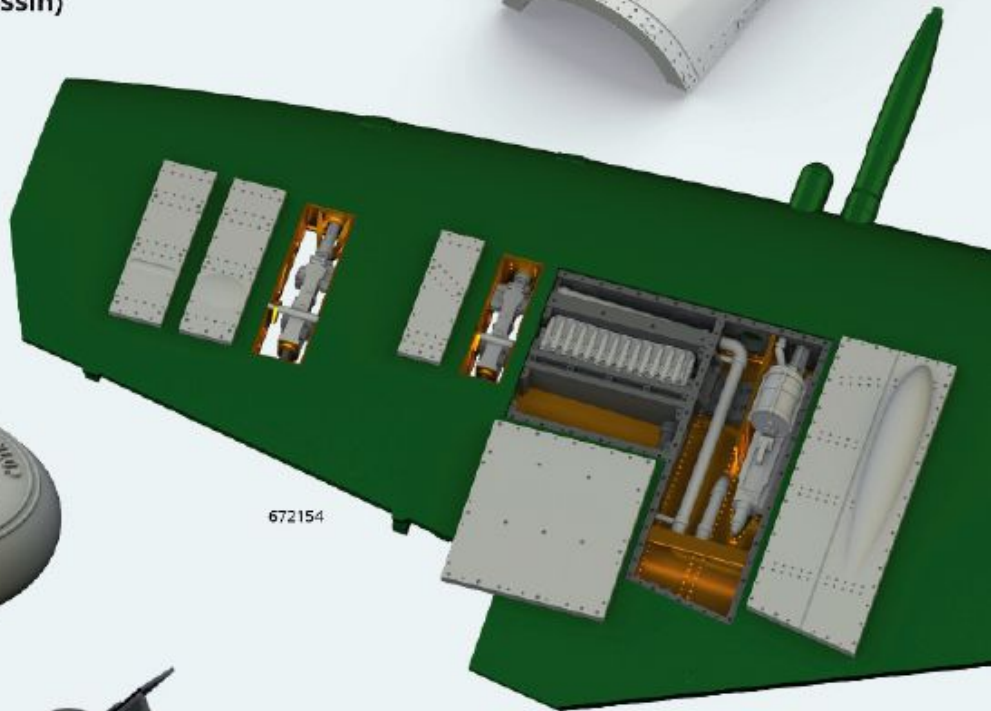

672154



672146



672156

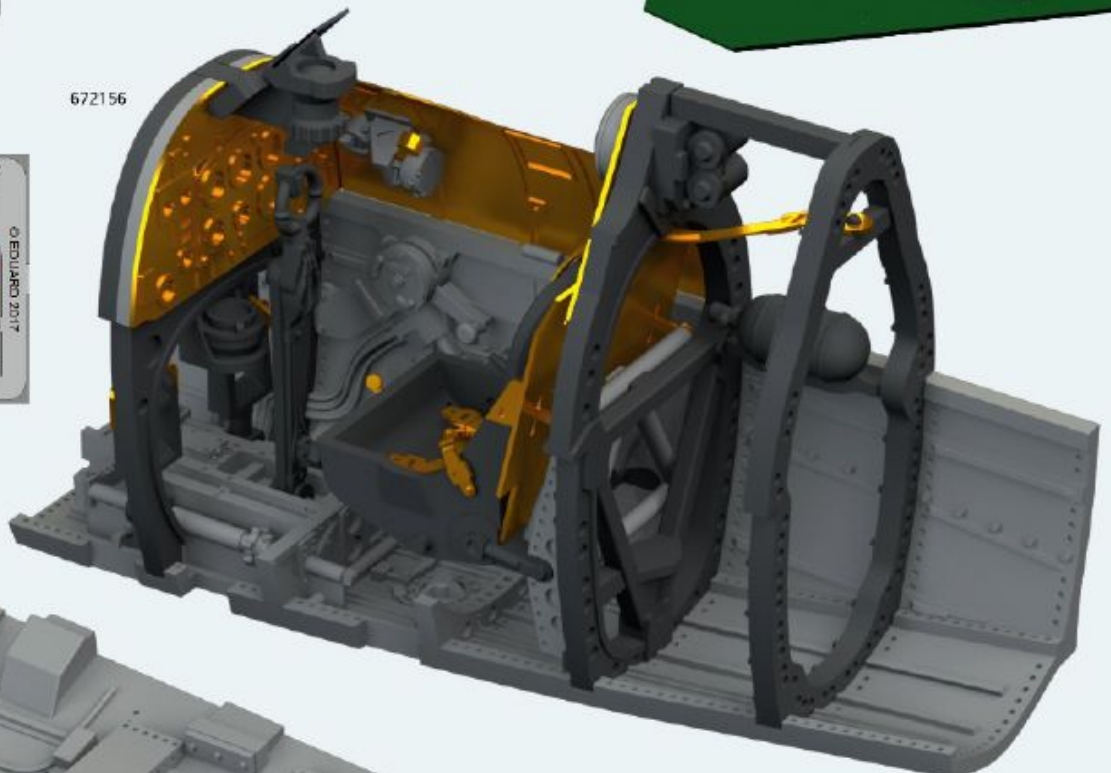

www.eduard.com