

# UNRAVELING THE INVISIBLE MAN

When H.G. Wells launched his series of 'scientific romances' at the turn of the century, his visions included a machine for journeying through time, an invasion of Earth by malevolent, tentacled Martians, and the tale of a man whose experiments with an invisibility formula drive him to megalomania.

The idea of invisibility had been a staple of fantasy, literature and even philosophy for ages, but Wells novel "The Invisible Man" was the first to place the concept in a scientific context and explore its ramifications. In the novel a man named Griffin develops a theory that a human being could become invisible by changing his or her "refractive index" to that of air, their body neither reflecting nor absorbing light. Griffin develops a technique to achieve this aim but discovers that he cannot reverse the process, and life as an invisible man begins inexorably to drive him mad.

Since the debut of Wells' novel the science-based concept of an invisible man has become popularized in other books and films, with special effects technology always pushed to its limits to create the illusion of an invisible man for an audience. Wells himself created many of the conventions of the genre by describing the effects of a marauding invisible man on the people and objects around him, and by creating a powerful visual image of Griffin himself in the early stages of the novel, particularly when he enters an English inn wrapped in a heavy overcoat and hat with his face obscured by bandages and large goggles. The revelation of the Invisible Man's true appearance — or rather lack of one — with Griffin terrifyingly unraveling the bandages and removing goggles, a false nose and wig to reveal the transparent nothingness underneath, is one of the great iconic images in the history of fantasy and horror.

Wells' concept not only plays on our fears of what we can't see but also explores ancient ideas of social responsibility—i.e., would we behave morally if we were invisible to society? Griffin starts out as morally compromised—he steals from his own father to finance his early experiments. But while the stress of being unable to reverse his invisibility begins to drive him mad, he's also well aware of what he can get away with as an invisible man and launches a "reign of terror" fit for a true monster.

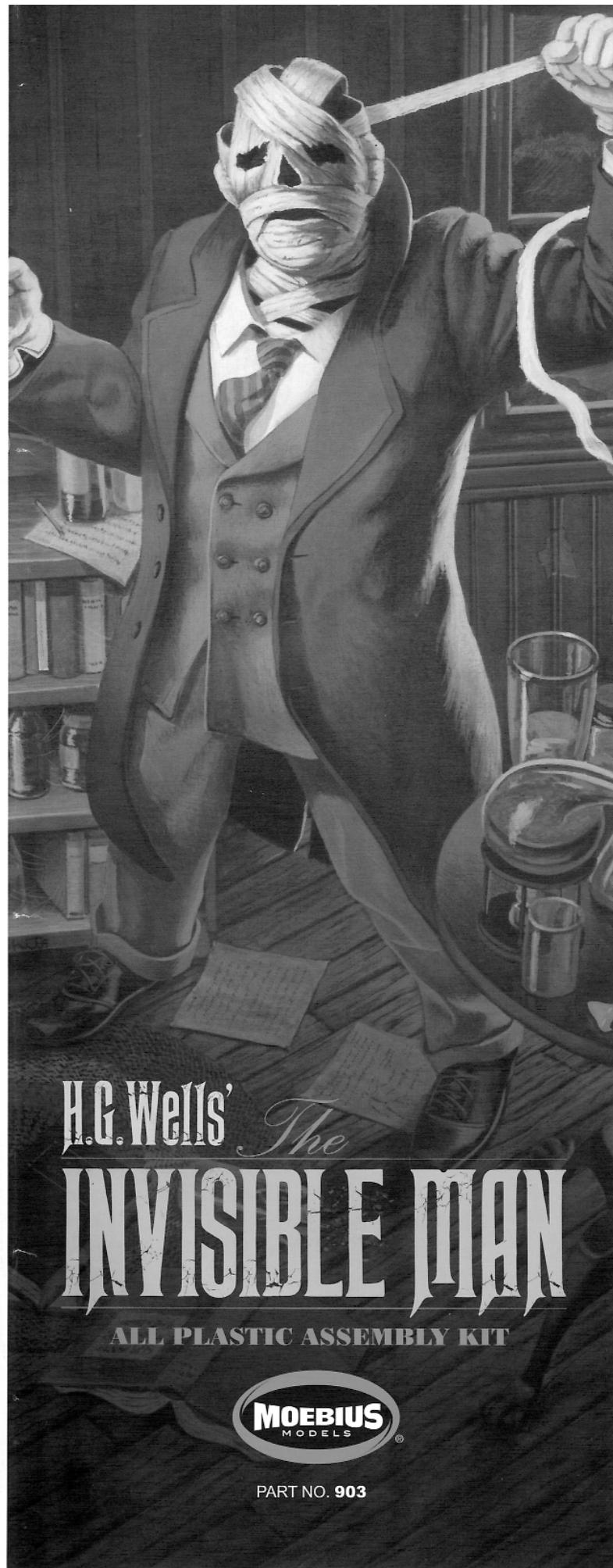

H.G. Wells' *The*  
**INVISIBLE MAN**

ALL PLASTIC ASSEMBLY KIT



PART NO. 903

- ! Study the instructions carefully and familiarize yourself with the parts and the assembly sequence before putting your model together. See the **Paint Chart** and **Tips** on back page.

# 1 BOOKCASE

- A Cement **Bottom Shelf** (#28) to **Back** (#26). Cement **Right Side** (#23) to **Back** and **Bottom Shelf** making sure that all the parts are square. Now cement the two **Middle Shelves** (#27) and **Top Shelf** (#25) in place, again making sure that everything is square. Finish by cementing the **Left Side** (#24) and two **Front Feet** (#29) in place. Set the assembled **Bookcase** aside to dry.
- B Cement **Books** (#31, #32 & #33) and **Large Beaker** (#96) in place on the **Bottom Shelf**.
- C Cement **Bottles** (#78 & #79), (#80 & #81), (#82 & #83), (#84 & #85), (#86 & #87), (#88 & #89), (#90 & #91) together. Then cement completed **Bottles** along with **Beakers** (#94 & #95) to **Lower Middle Shelf**.
- D Cement **Skull Halves** (#53 & #54) together, then cement the **Skull** and **Books** (#30) in place on the **Upper Middle Shelf**. Cement **Frog Halves** (#69 & #70) together and drop the **Frog** into **Beaker** (#97); set aside.
- E Cement **Sitting Rat Internal Parts** (#40) to **Sitting Rat Back Half** (#65); cement **Sitting Rat Front Half** (#67) to **Sitting Rat Back Half** (#65). Finish the **Sitting Rat** by adding his **Leg** (#68) and **Tail** (#66). Set the **Sitting Rat** aside. Cement **Climbing Rat Internal Parts** (#39) to **Climbing Rat Back Half** (#60). Cement **Climbing Rat Front Half** (#62) to **Climbing Rat Back Half** (#60). Finish the **Climbing Rat** by adding his **Front Leg** (#63), **Back Leg** (#64) and **Tail** (#61). Set the **Climbing Rat** aside. Cement the **Glass Cage** (#71) to **Base** (#52) then add the two **Rats** to the **Cage**.
- F Cement **Bottle Halves** (#99 & #100) together. Cement **Glass Cage Base** (#52) to the Top Shelf. Cement **Beaker** (#97) with **Frog**, **Bottle** (#99 & #100) **Paper** (#48), **Fountain Pen** (#47) and **Glass** (#98) to **Top Shelf**. Set the completed **Bookcase** aside.

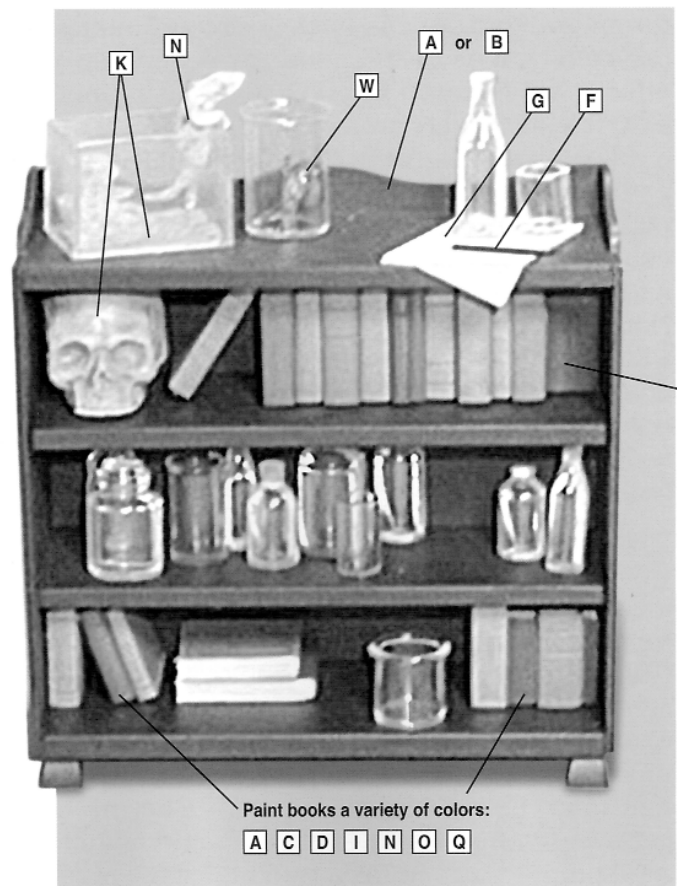
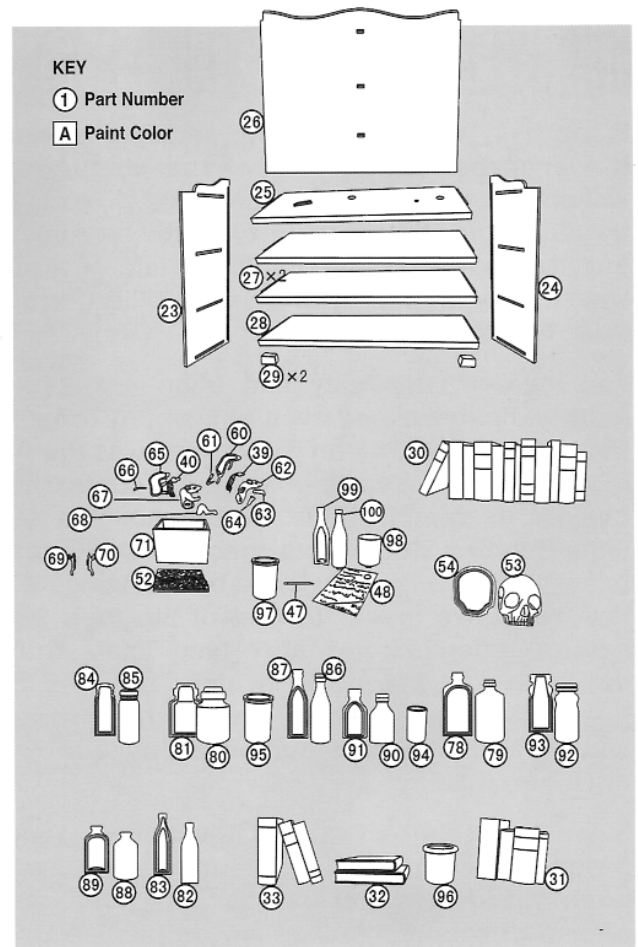

# 2 TABLE

**A** Cement **Alcohol Lamp** (#74 & #75) together then cement it to **Alcohol Lamp Stand Base** (#36). Cement the six **Alcohol Lamp Stand Uprights** (#35) to the **Alcohol Lamp Stand Base** (#36). Cement the **Alcohol Lamp Stand Top** (#34) to the **Uprights** (#35); set the assembled **Alcohol Lamp** aside for now.

**B** Cement **Curved Flask Halves** (#72 & #73) together. Cement the **Bottles** (2 of each — #76 & #77) and (#107 & #108) together. Cement **Jar** (#105 & #106), **Flasks** (#103 & #104) (#105 & #106), and **Large Graduate** (#109 & #110) together. Cement **Flask Holder** (#37) to **Flask Holder Base** (#38).

**C** Cement **Table Base** (#50) to **Table Pedestal** (#49). Cement **Table Top Halves** (#58 & #59) together; cement the **Table Top Assembly** to the **Table Pedestal Assembly**.

**D** Cement assembled **Alcohol Lamp** to locator hole in **Table Top**. Cement **Flask Holder** to locator hole in **Table Top**. Cement **Curved Flask** to **Alcohol Lamp** and **Flask Holder**. Complete **Table** by cementing the assembled **Bottles**, **Jars**, **Flask** and **Large Graduate** in place along with the **Nose** (#46) and **Mortar and Pestle** (#111 & #112). Set the completed **Table** aside.

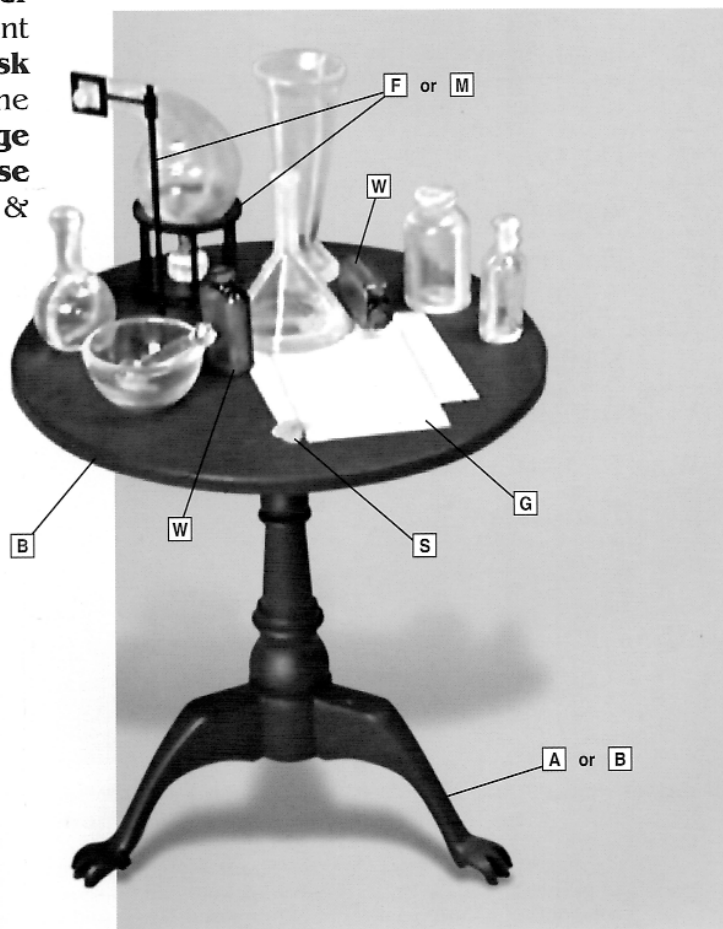
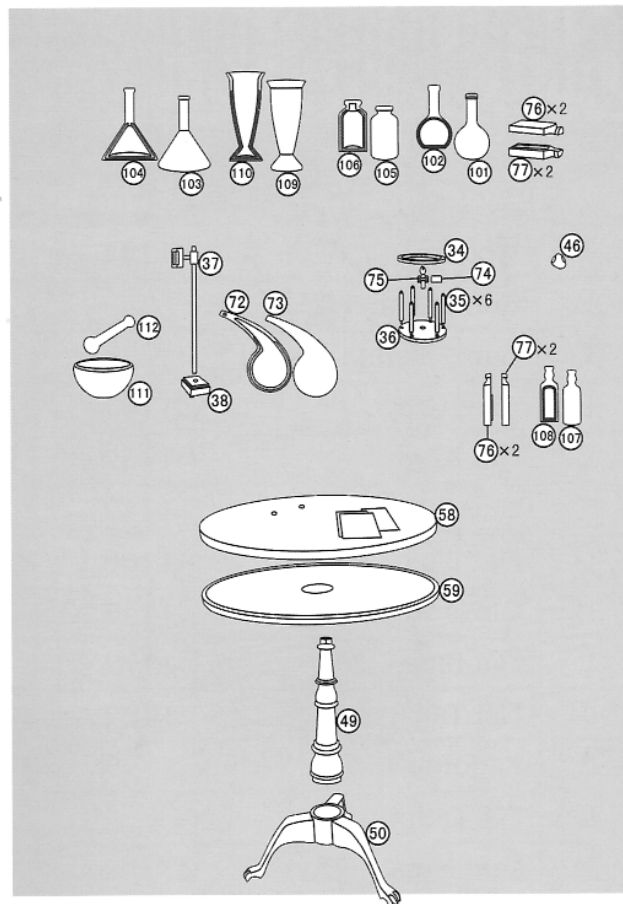

Paint books a variety of colors:

A C D I N O Q

# 3 INVISIBLE MAN

**A** Cement **Front Trousers Half** (#5) to **Rear Trousers Half** (#6). Cement **Head Halves** (#7 & #8) together and cement **Head** into **Shirt Front** (#1). Cement **Shirt Front** to **Front Trousers Half** (#5); cement **Coat Back** (#2) to **Rear Trousers Half** (#6) and collar of **Shirt Front**. Cement **Left Coat Front** (#3) and **Right Coat Front** (#4) to the **Coat Back** (#2). Set **Body Assembly** aside.

**B** Cement the **Goggles** (#41 & #42) together; place the **Goggles** between **Right Hand Halves** (#11 & #12) and cement the **Right Hand Halves** together. Cement **Right Arm Halves** (#15 & #16) together and cement the **Right Hand** into the **Right Sleeve**. Set assembled **Right Arm** aside.

**C** Cement **Left Arm Halves** (#13 & #14) together; cement **Left Shirt Cuff Halves** (#21 & #22) together and cement **Left Shirt Cuff** into **Left Arm**. Set assembled **Left Arm** aside.

**D** Cement **Bandages** (#43 & #45) to **Left Hand Front Half** (#9); cement **Left Hand Rear Half** (#10) in place. Set assembled **Left Hand** aside.

**E** Cement **Right Arm** and **Left Arm** to **Body**. Cement **Left Foot Halves** (#17 & #18) together; then cement **Right Foot Halves** (#19 & #20) together. Place the assembled **Feet** on a flat surface and cement the assembled **Body** to the **Feet**. NOTE: take time at this stage to make sure that the figure will stand by itself.

**F** Cement **Bandage** (#43) to the back of the **Head** and **Bandage** (#45) in place to the **Left Arm**. The finished assembly will now have the **Left Hand** suspended above the **Shirt Cuff**. Cement the last **Bandage** (#44) to the **Left Arm**. Set assembled **Invisible Man Figure** aside.

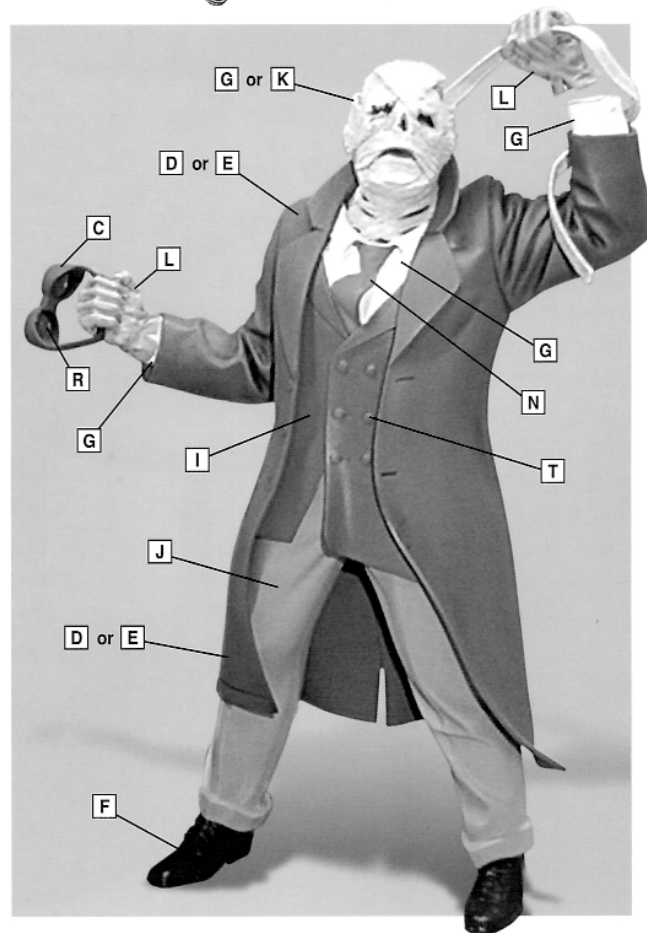
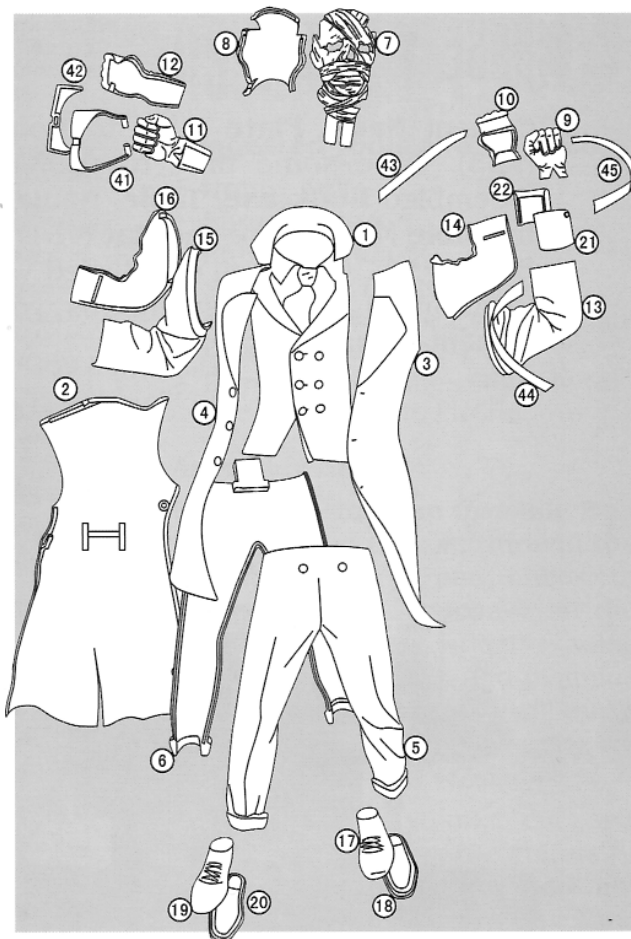

# 4 BASE

Cement **Name Plate** (#56) to **Book Pile** (#55). Take some time to position the assembled **Bookcase**, **Table**, **Name Plate**, **Invisible Man Figure** and **Hat** (#51) on the **Base** (#57). Once you're satisfied with the location of these assemblies you can cement them in place.

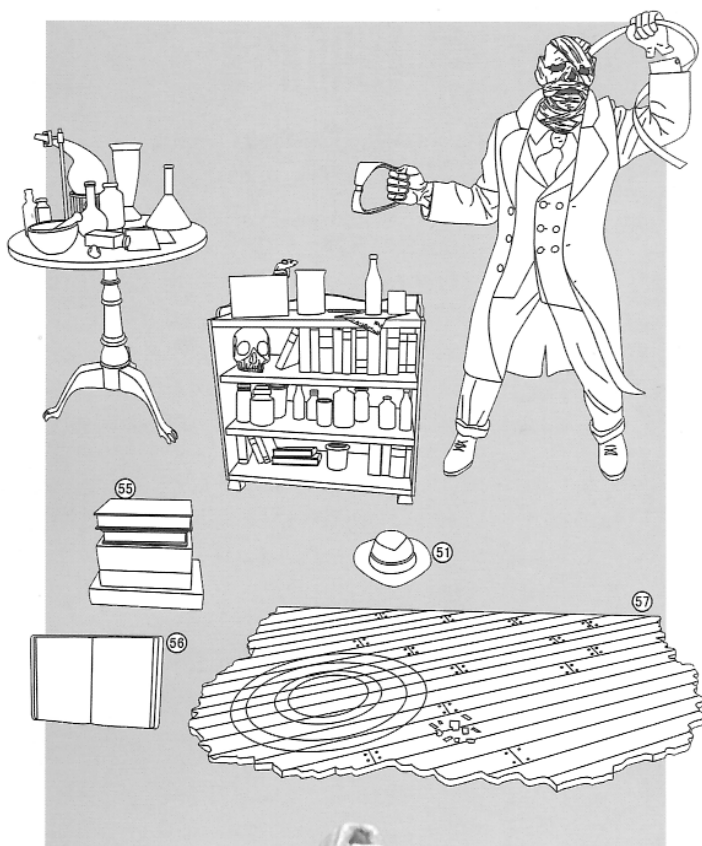
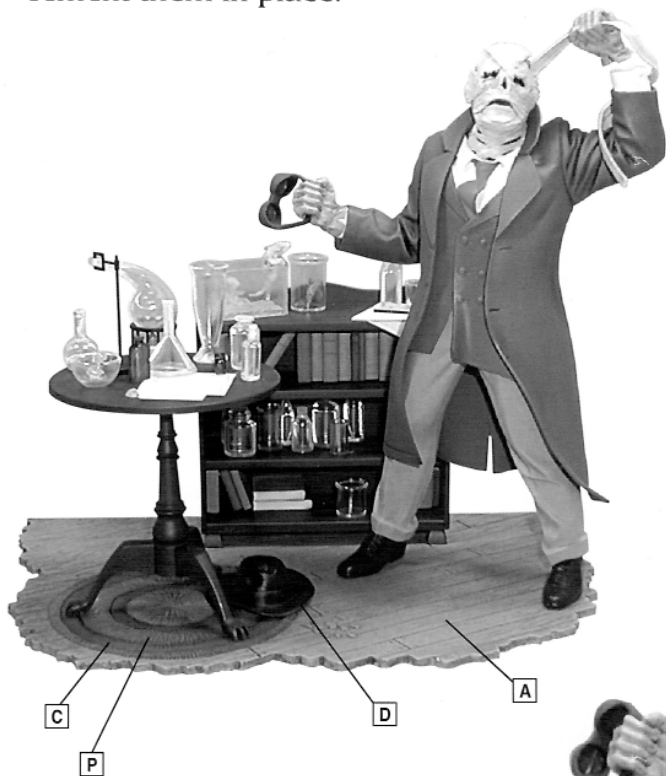

Paint books a variety of colors:  
**A C D I N O Q**

# PAINT SUGGESTIONS

We have provided our interpretation of colors for **The Invisible Man** kit; feel free to choose other colors that you feel are more appropriate.

code	color	testors enamels	testors model master enamels	testors acryl
A	Wood	1141	1735	4673
B	Burnt Umber		2005	4605
C	Burnt Sienna		2007	4608
D	Dark Gray	1163	1723	4752
E	Flat Black	1149	1749	4768
F	Gloss Black	1147	1747	4695
G	Flat White	1168	1768	4769
H	Gloss White	1145	1745	4696
I	Flat Blue	1172	2012	4612
J	Flat Tan	1167	1963	4709
K	Radome Tan		1709	4722
L	Flat Gull Gray		1729	4763
M	Gun Metal		1795	4681
N	Flat Red	1250	1705	4714
O	Leather	1166	1736	4674
P	Flat Intermediate Blue		1720	4744
Q	Flat Green	1171	1714	4734
R	Gloss Green	1124	2028	4669
S	Flat Flesh		2001	4601
T	Gold	1144	1744	4671
U	Silver	1146	1790	4678
V	Transparent Red			4630
W	Transparent Green			4668
X	Transparent Blue			4658



moebiusmodels.com

Kit design, packaging illustration and packaging design by **Chris White**.  
The Invisible Man history by **Jeff Bond**.

©2019 Moebius Models, 5515 Moreno St., Montclair, CA 91763  
Made and printed in China. Model shown was built and finished by a professional modeler. Glue and paint required for assembly — sold separately.

# ASSEMBLY TIPS

## Suggested Tools and Materials

- Hobby Knife
- Sprue Cutters
- Rubber Bands
- Spring-type Clothes Pins
- Plastic Cement or Cyanoacrylate Glue ("Super Glue")
- Paints and Brushes suitable for use with Styrene Plastic

## Assembly Notes

Before you start **The Invisible Man** kit, take time to read through the instruction sheet and check to make sure that you have all the parts. Some time spent reading the instruction sheet and planning the best way to proceed will make your model building experience more efficient and enjoyable.

As you assemble your kit, cut parts off the sprue with sprue cutters or a sharp hobby knife — do not break parts off the sprue. Take extra care with clear parts because clear styrene is brittle and is easier to damage. Take time to test fit parts before gluing them in place.

## Painting Your Model

If you wish to paint **The Invisible Man** model, it is best to begin by painting many parts and sub-assemblies before you cement them in place. Familiarize yourself with the paint color codes (see chart at left) and determine which parts you will need to paint before you begin assembly of your model. It is helpful to wash parts that you will be painting with warm water and detergent to remove any mold release agent from the plastic.

For missing parts, do not return to place of purchase. Replacement parts are available direct. Please contact us at:

[customerservice@moebiusmodels.com](mailto:customerservice@moebiusmodels.com)

Please provide kit number and part number. Missing parts will be replaced at no charge, but a shipping and handling fee is required.