

SOUTH AFRICAN AIR FORCE MK6 SABRES

DECAL SET # 72.23 1/72 SCALE

98.23 1/48 SCALE

#39.04 1/32 SCALE

**Leading
Edge**
MODEL

Markings for two complete aircraft including
all stencils in English and Afrikaans.

Optional markings for either
#1 or #2 squadrons in
natural metal.

NATURAL METAL



DEEP BUFF
 OLIVE DRAB
 LIGHT ADMIRALTY GREY

Colour match information inside.

Optional markings for either
#1 squadron or 85th AFS
in camouflage scheme.

All Sabres were transferred to #1 Sqn in 1963 and then in 1975 to the 85 AFS where they flew until retirement in 1980. A few still fly today privately owned. The Canadair MK6 was easily the best dog fighting variant of all F-86s produced. The short span slatted 6-3 wing, 7500 lb thrust Orenda 14 engine and fine tuned balancing of controls made this a fact as well as the empty weight was over 300 lbs lighter than other Sabres.

85 Advanced
Flying School
(1976 - 1980)

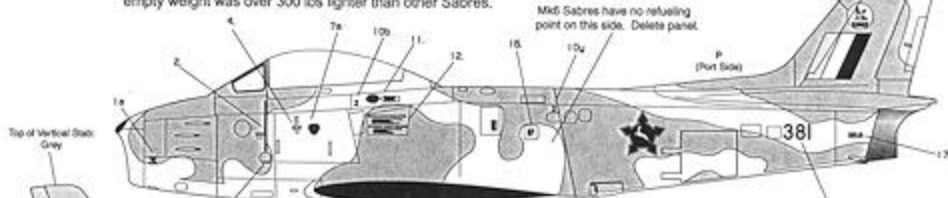

SAAF CAMOUFLAGE SABRE 6 Stencil and Markings Location Instructions

OPTIONAL AIRCRAFT #s
Any of the below #s may be used
with either squadron.
350, 354, 358, 372,
380, 381, 383, 385,



Use smaller castle decals provided for the camouflage scheme.

Using the smallest #s, apply last two digits of aircraft on nose gear door on both sides of towing placard.

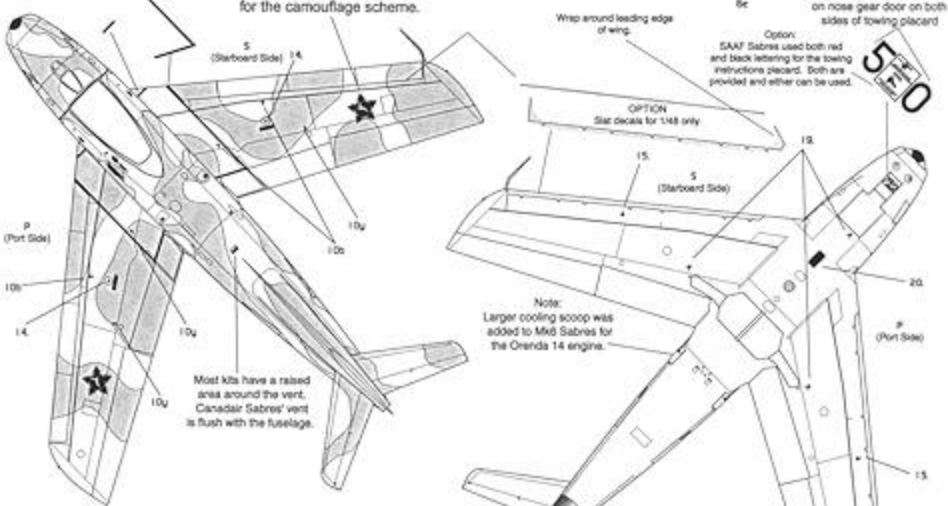

Most kits have a raised area around the vent. Canadair Sabres' vent is flush with the fuselage.

Note:
Larger cooling scoop was added to Mk6 Sabres for the Orenda 14 engine.

COLOURS

Exposure to the sun and elements faded the paint as well as dulling the finish.

Starting as a gloss and eventually appearing semi gloss to matt.

Deep Buff (FS#10257, BSC# 360), Olive Drab (FS# 14098, BSC#298)

represents the darkest shades of these colours appearing on the aircraft.

Light Admiralty Grey should be a light grey shade such as FS#15622. Colour swatch shown on the colour instruction sheet is a good match. A very light grey with a slight tint of green / blue.

Leading
Edge
MODELS

SAAF NATURAL METAL SABRE 6
General Markings Location Instructions

#1 Squadron (blue / orange trim)

A F P
350 361 382

#361 (F):

At time of release of this decal this aircraft has been restored and is flying again in South Africa.



#1 SQUADRON OPTION 1/72 & 1/48
Full nose tank decal used or trim stripe decal provided to apply after painting nose area blue.

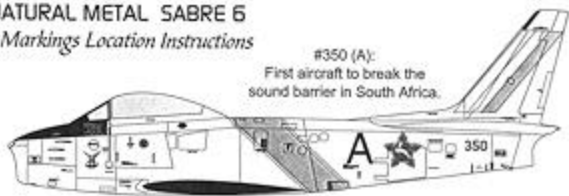

#350 (A):
First aircraft to break the sound barrier in South Africa.

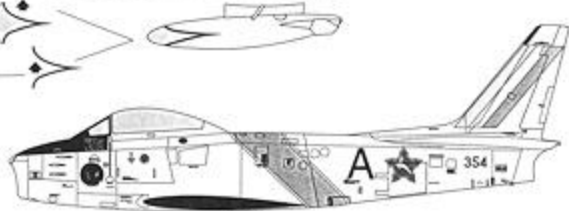

OPTION
1/72 & 1/48 ONLY
Use decal or paint nose of tank.



#2 Squadron (red / black trim)

A L N
354 362 374



FUSELAGE BAND STRIPE TEMPLATES
(Optional for 1/72 & 1/48)

Cut out, apply around fuselage and mark location for masking and painting. Apply trim stripe decals over painted stripe.

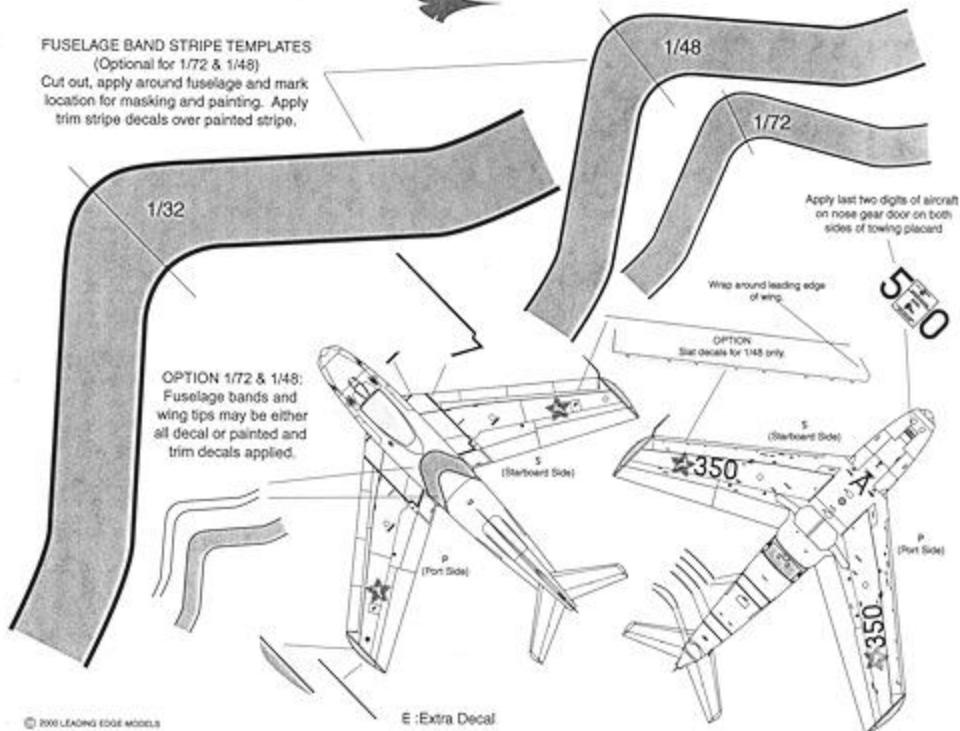

E : Extra Decal

SAAF NATURAL METAL SABRE 6
1/48 & 1/32 Scale Stencil Location Instructions

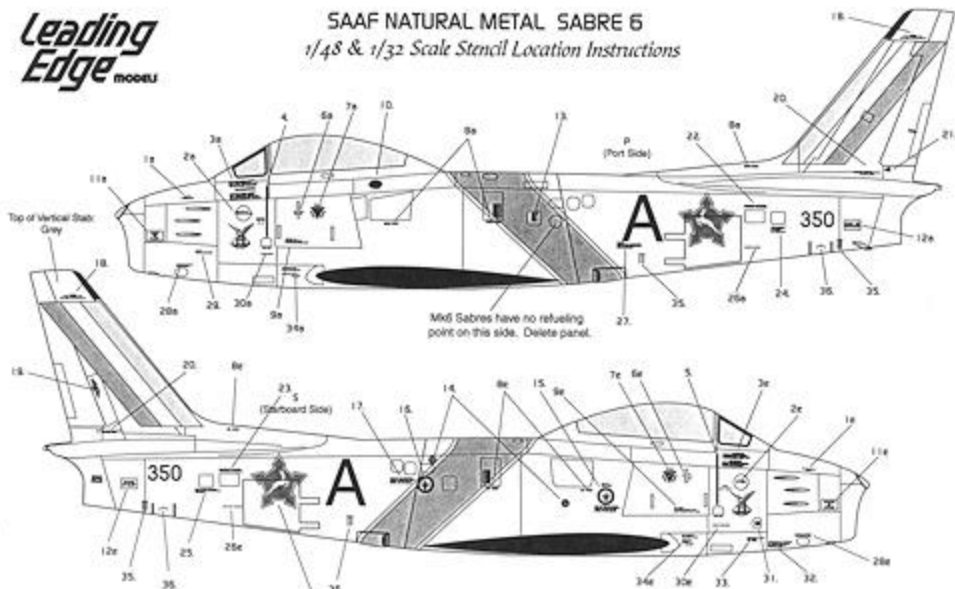

Use larger castle decals provided for the natural metal scheme.

Option:
SAAF Sabres used both red and black lettering for the towing instructions placard. Both are provided and either can be used.

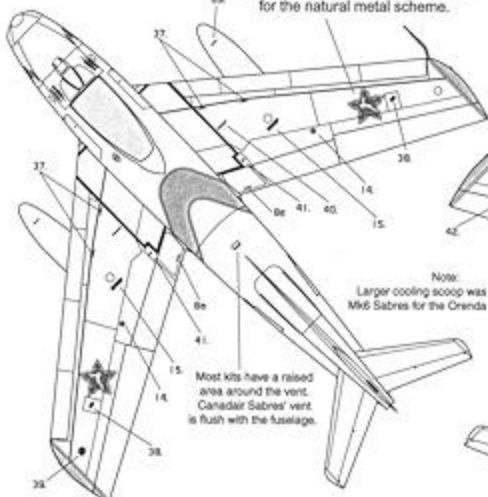

Note:
Larger cooling scoop was added to Mk6 Sabres for the Orenda 14 engine.

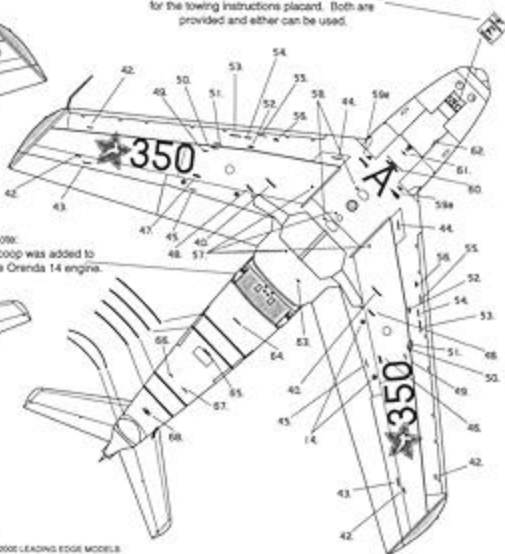

Researched by Charlie Hugo.
Additional help by William Marshall.
All graphics and decal printing by:
Leading Edge Models

