

F-6D

Photo recon P-51

Follow Kit instructions up to step 4.
Substitute Kit part A1 for LSM part A.
It should snap into place. Use a small
amount of superglue to hold it in place.

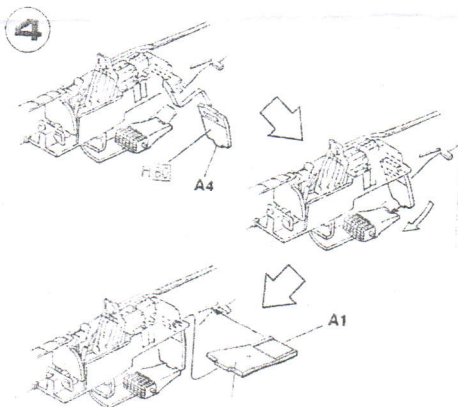

Measure the width of the new panel.
Make a mark the same width on the left
Fuselage part A17, measured from the
Panel line just ahead of the wheel well
opening.

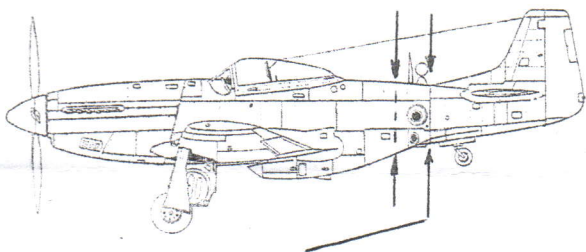

Carefully cut the tail off at the panel
line .

Use a saw and cut ahead of the panel
line ,then sand to the line and test fit
the new panel. When you are satisfied
with the fit, glue the new panel in place.

Now remove the remainder of the fuselage
area at the mark made previously.
Cut a bit less off and sand the fuselage till
you get a good fit.