

D

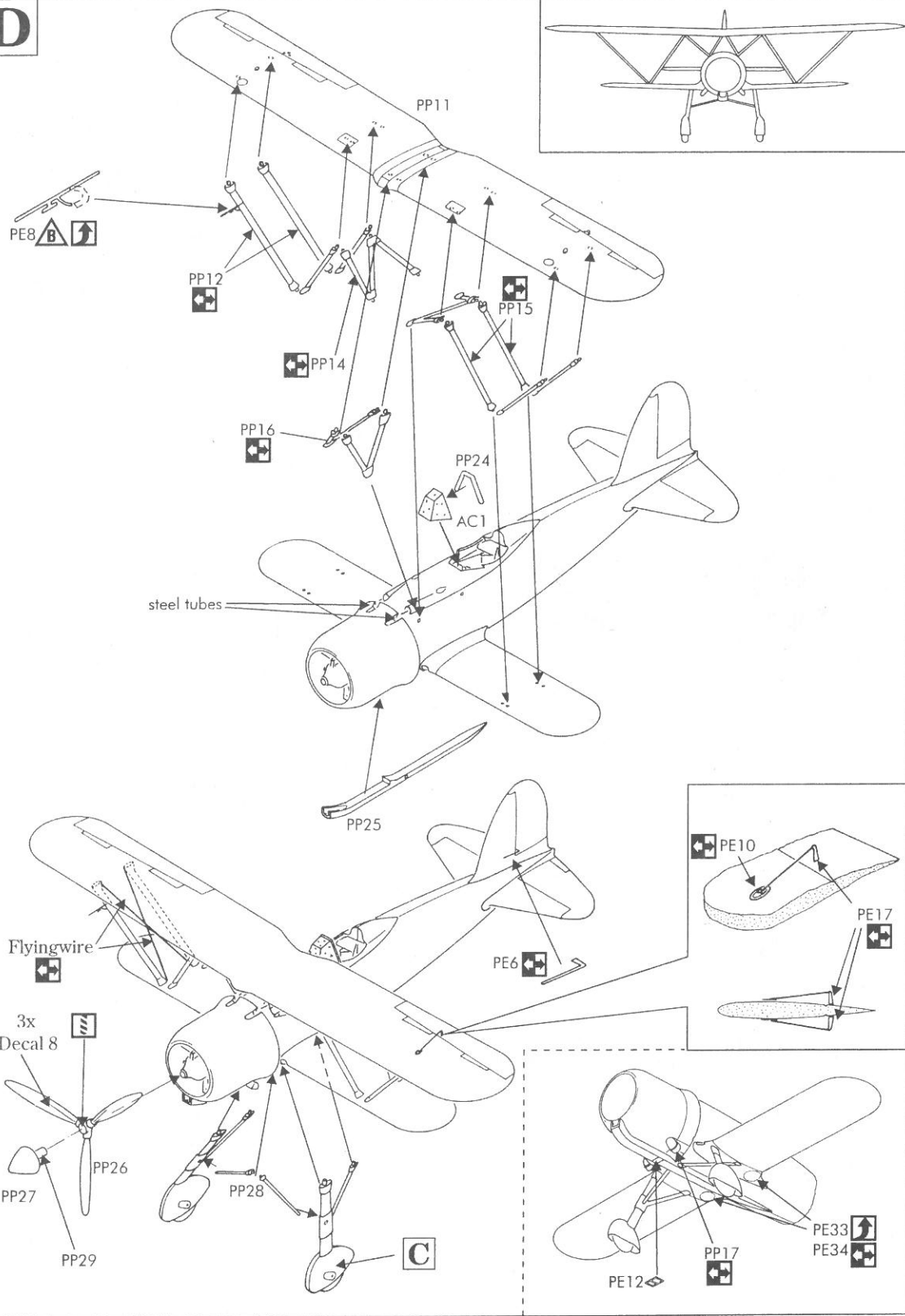

Classic Airframes

Fiat CR-42 Falco

1/48 SCALE PLASTIC KIT

95-402

PLASTIC PARTS - PP

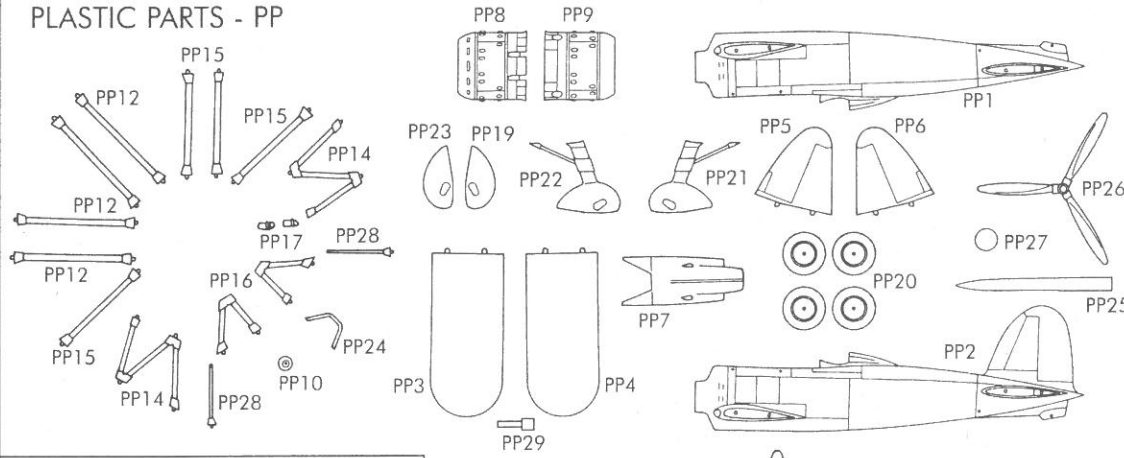

RESIN PARTS - PU

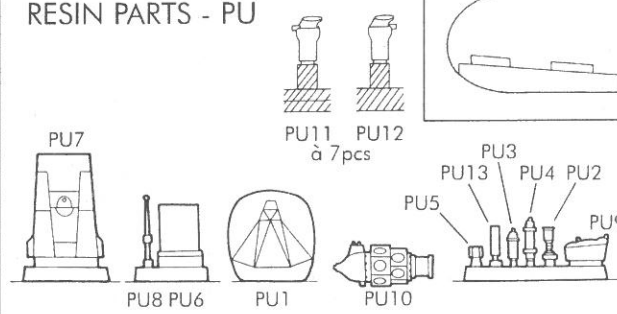

ACETATE PART - AC



FOIL



STEEL TUBES

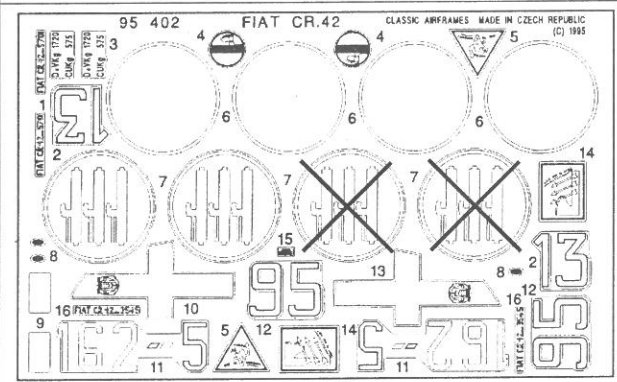
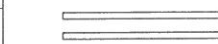

DECAL SHEETS

✗ not used

PHOTO ETCHED DETAIL PARTS - PE

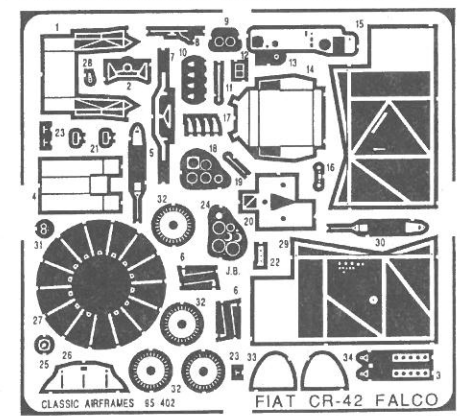

NOTE: TO ATTACH PHOTO ETCHED, WHITE METAL AND RESIN PARTS, IT IS RECOMMENDED TO USE SUPER GLUE



BEND
PLIER SIL VOUS PLAÏT
BITTE BIEGEN
OHNOUT

OPEN HOLE
FAIRE UN TROU
OFFNEN
VYVRTAT OTVOR

SYMETRICAL ASSEMBLY
MONTAGE SYMÉTRIQUE
SYMMETRISCHE AUFBAU
SYMETRICKÁ MONTÁŽ

WHITE
BLANC
WEISS
BÍLÁ

BLACK
NOIR
SCHWARZ
ČERNÁ

RED
ROUGE
ROT
ČERVENÁ

LIGHT GRAY
GRIS CLAIR
HELLGRAU
SVĚTLÉ ŠEDÁ

BROWN
BRUN BOIS
BRAUN
HNĚDÁ

ALUMINIUM
ALUMINIUM
ALUMINIUM
HLINÍK

A COCKPIT

Interior color - E

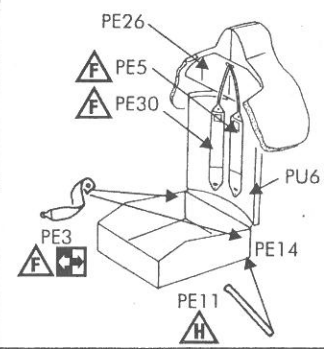
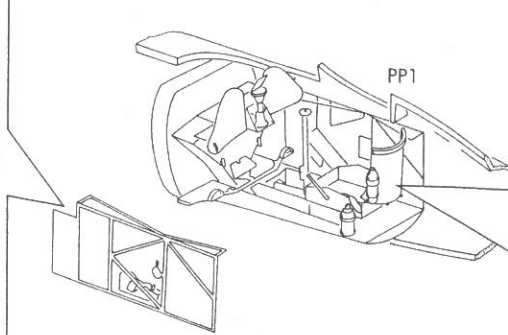
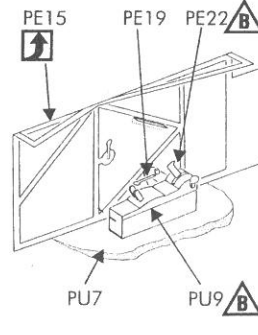
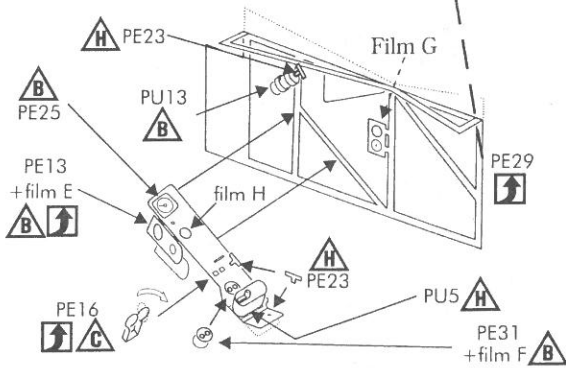
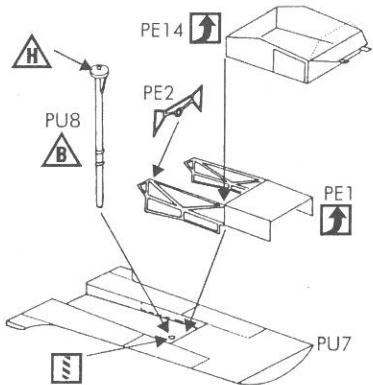
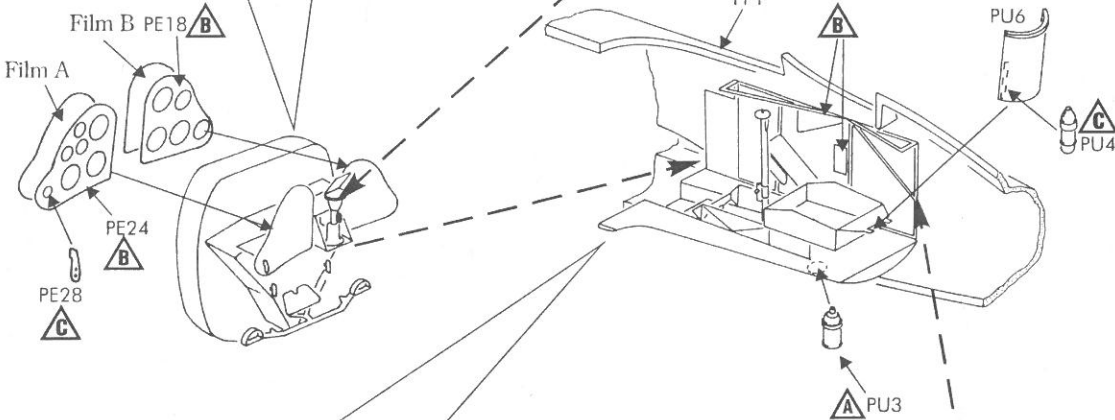
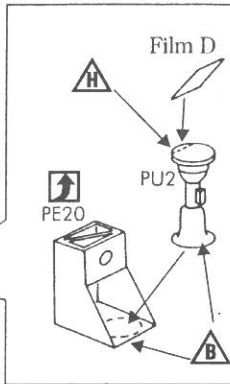
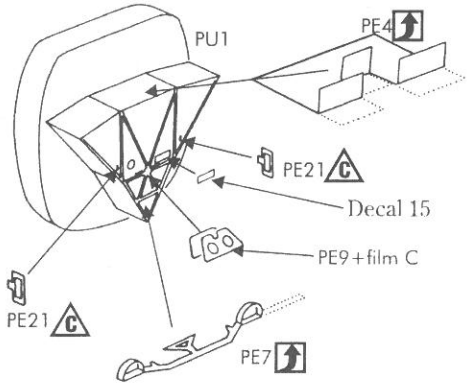

B

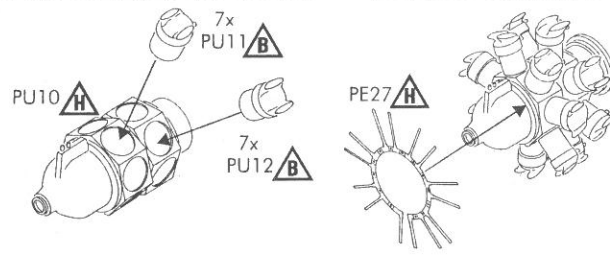
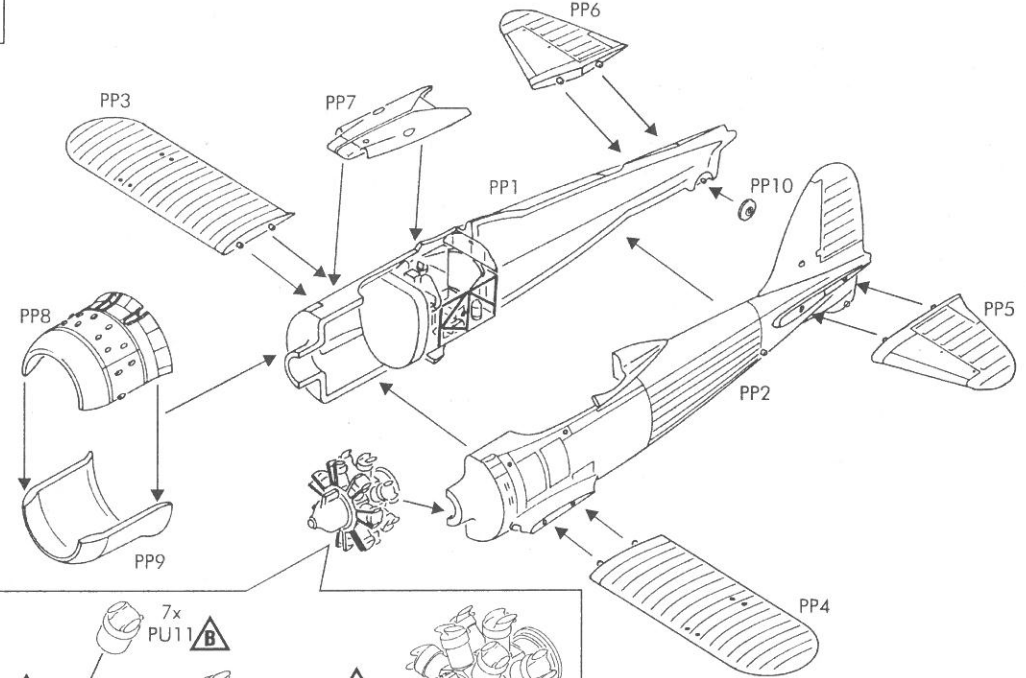

C UNDERCARRIAGE

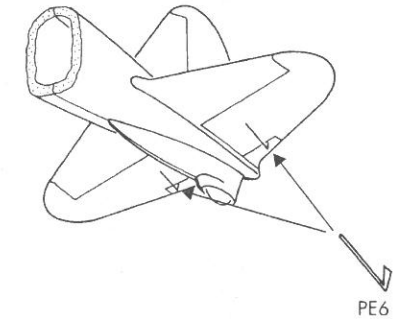
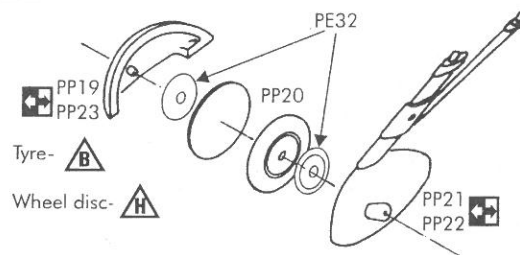

FIAT CR.42

95 402

PAINTING & MARKING GUIDE

A. CR.42, 83^a Sqd., 18^o Gruppo, 3^o Stormo, Belgium, Autumn 1940.

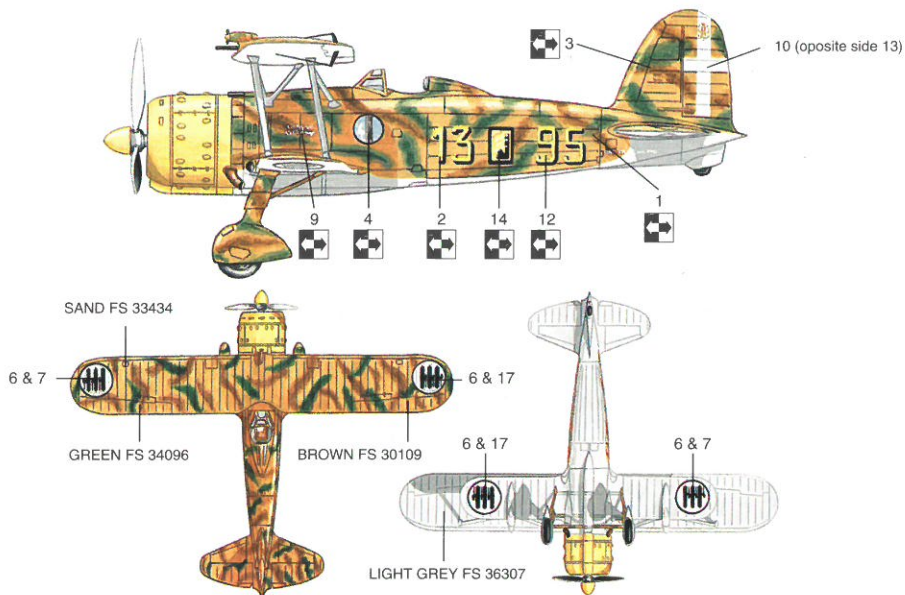

A. CR.42, 162^a Sqd., 161^o Gruppo, the Aegean theatre, Isle of Scarpanto.

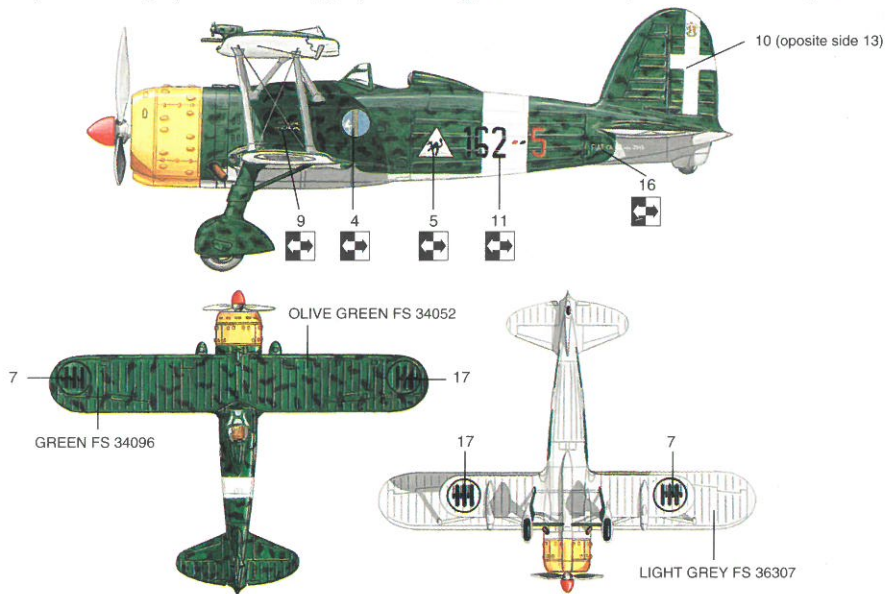

FIAT CR.42

The Fiat CR.42 was the last biplane fighter to be manufactured during the Second World War. Entering service with the Regia Aeronautica in late 1939, the plane was praised by its pilots for its exceptional maneuverability and flying characteristics.

However the nimble CR.42 was a classic example of pushing a good idea too far. Italy's experience with its predecessor, the CR.32 during the Spanish Civil War had been outstanding. It led to the flawed conclusion that the biplane fighter was still an effective weapon. It was to be the last of Celestino Rosatelli's biplane fighters.

The CR.42 was structurally very similar to its predecessor, a combination of metal and fabric skinning on the fuselage, with fabric covered flying surfaces. It was powered by one 840 h.p. Fiat A 74 R.C. 38 fourteen-cylinder radial air-cooled engine. Armament, two 12.7 mm Breda-SAFAT machine guns with 400 r.p.g.

Several other nations purchased the CR.42. Hungary ordered 52, these being employed primarily in the home-defence role, they also briefly participated in the opening stage of Barbarossa. Belgium ordered 34, in May 1940 these Fiats were the first to see action, albeit on the allied side, about half of them were destroyed on the ground and the survivors played little part in the fighting over Belgium. Sweden ordered 72 aircraft and these served until 1945, a few were employed as target tugs.

The Regia Aeronautica used the CR.42 as part of its contribution in the Battle of Britain, but over the Channel, facing modern fighters, lacking even radio equipment, its obsolescence was exposed and it was quickly withdrawn. However in the more primitive conditions found over the Balkans, Africa, the Mediterranean and Middle East, the CR.42 soldiered on as fighter-bomber, night-fighter and bomber escort.

The end of the war found the CR.42 in the hands of the Luftwaffe, used as anti-partisan and night-ground-attack fighter, over the Balkans.

Technical data:	Power Plant	one 840 h.p. Fiat A 74 R.C. 38
	Span	31' 9 3/4''
	Length	27' 2 3/4''
	Max. speed	267 mph at 16405 ft.
	Range	481 miles
	Armament	two 12.7 mm Breda-SAFAT machine guns

For additional technical and operational details, we recommend:
Nicola Malizia's IL FIAT CR.42 (1977)
Aircraft in Profile The Fiat CR.42 Doubleday (1969)
La Bancarella Aeronautica (1995)

A SPECIAL THANKS MUST GO TO "LA BANCARELLA AERONAUTICA" PUBLISHING HOUSE OF TORINO FOR THEIR HELP IN PREPARING THIS KIT.

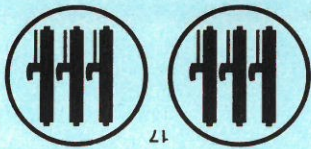

21

95 402

FIAT CR.42

CLASSIC AIRFRAMES MADE IN CZECH REPUBLIC
(C) 1995

FIAT CR.42 95-402-3201

0.1Kg 1720

0.1Kg 575

0.1Kg 1720

0.1Kg 575

3

1



2

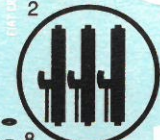

14

8



9

16 162-291

11

5

95

13

5-291

11

10



12

13 55

16

PRODUCTEAM

15

8

9

10

11

12

13

14

15

16

17

18

19

20

21

22

23

24

25

26

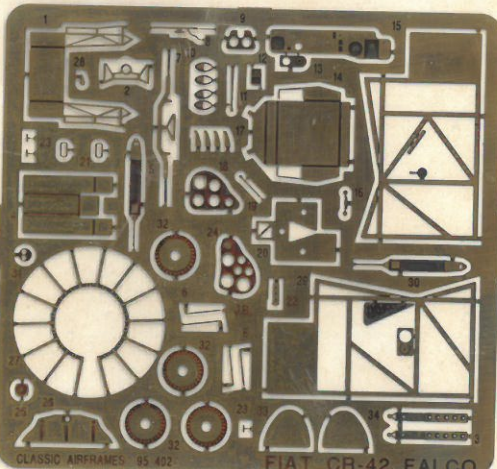
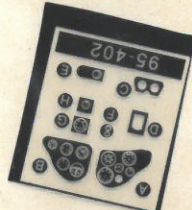

CLASSIC AIRFRAMES 95-402

FIAT CR-42 FALCO