



# FREE STATE HOGS

104TH FIGHTER SQUADRON A-10A/C 1989-2009



**AFTERBURNER  
DECALS** AFTERBURNERDECALS.COM

**AD48-052  
\$20.00**

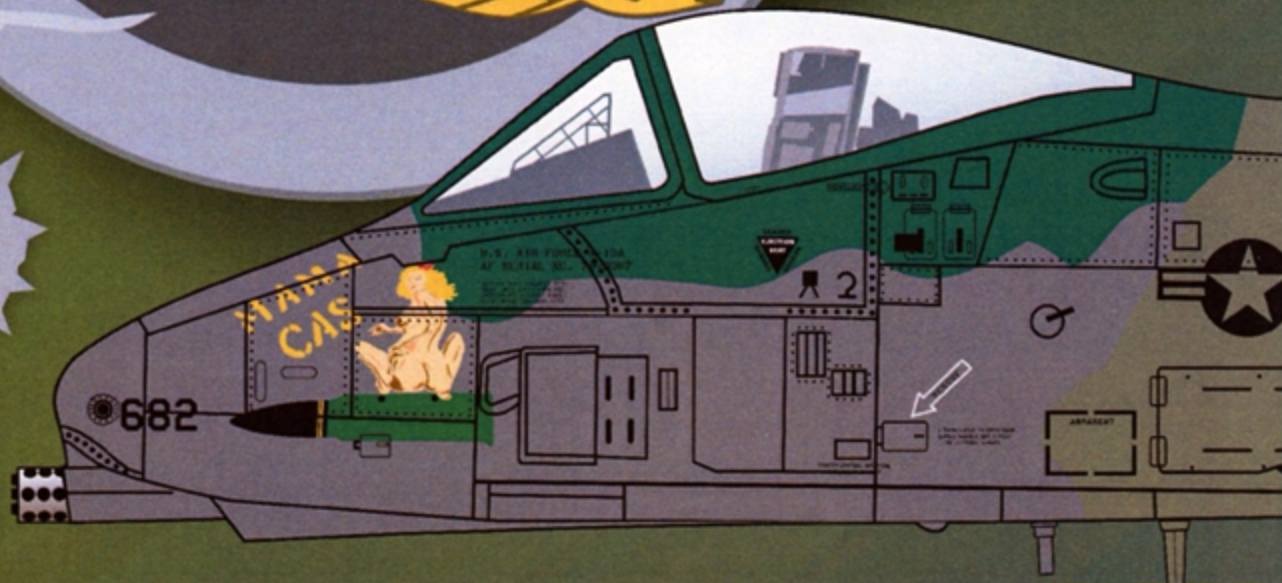

**OPTIONS FOR 34 AIRCRAFT!**

DECALS PRINTED BY



**COPYRIGHT 2009 AFTERBURNER DECALS ALL RIGHTS RESERVED**



# SENTRY INDEPENDENCE 1989

SENTRY INDEPENDENCE WAS AN ANNUAL EXERCISE HELD AT VOLK FIELD AND TRAUX FIELD, WISCONSIN. THE PURPOSE OF THE EXERCISE WAS TO SIMULATE THE DEFENSE OF WESTERN EUROPE, AND AS SUCH AS MANY AS 30 UNITS WOULD PARTICIPATE DURING THESE EVENTS. THE 104TH SENT SIX AIRCRAFT FOR THE EVENT, ALL OF WHICH WERE PAINTED WITH TEMPORARY NOSE ART.

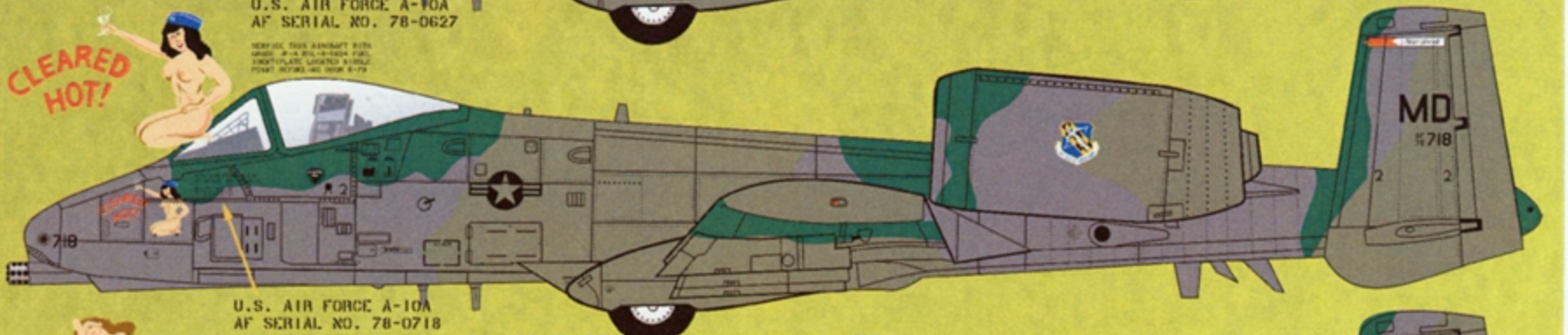
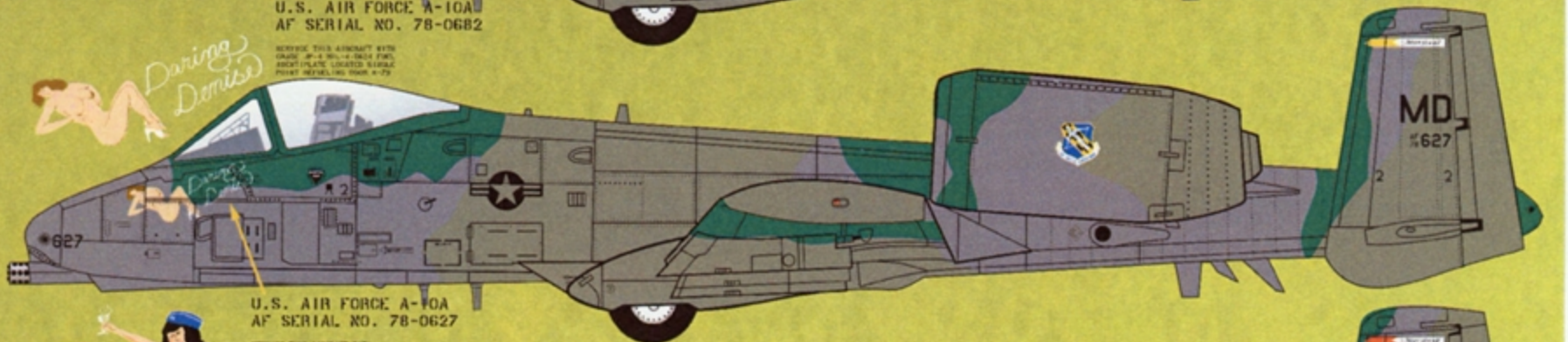
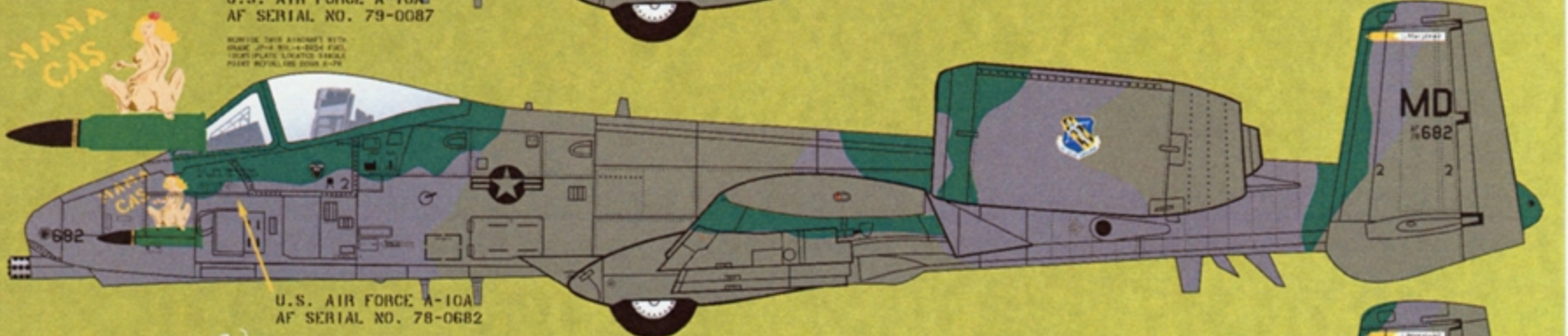
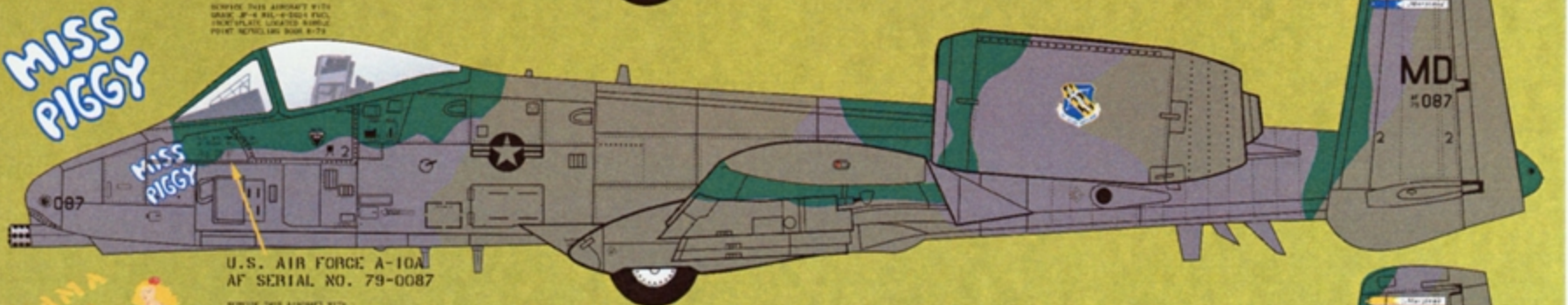

A PAIR OF F-16s (ONE UNIT SHALL REMAIN NAMELESS) GOT LOW AND SLOW IN FRONT OF 'PLAYHOG' AND 'IRON MAIDEN' DURING THE EXERCISE. THEY WERE 'SHOT DOWN' AND KILL MARKS WERE PAINTED ON THE JETS FOR THE SHARED KILLS.

THESE AIRCRAFT HAD NOT YET BEEN MODIFIED WITH THE LATEST UPGRADE - NO SLIME LIGHTS, AND NO RADAR ALTIMETER BUMPS



# 1991 GUNSMOKE WORLD CHAMPS

THE 104TH FIGHTER SQUADRON WAS CONSIDERED BY MANY TO BE A LONG SHOT TO WIN THE USAF'S BIENNIAL AIR TO GROUND GUNNERY AND BOMBING COMPETITION. THE UNIT SENT ITS RECENTLY UPGRADED LASTE (LOW ALTITUDE SAFETY AND TARGETING ENHANCEMENT) JETS WHICH GREATLY IMPROVED THE AIRCRAFT'S WEAPONS DELIVERY ACCURACY. OUTPERFORMING UNITS EQUIPPED NEWER AIRCRAFT SUCH AS THE F-16 AND F-15E, THE A-10 ONCE AGAIN PROVED ITS WORTH AND HELPED SECURE ITS ROLE IN THE USAF'S POST COLD WAR INV

LASTE EQUIPPED AIRCRAFT WITH RADAR ALTIMETER BLISTERS

U.S. AIR FORCE A-10A  
AF SERIAL NO. 78-0682

PILOT LTCOL G. MORGAN  
C/C TSGT G. SCHWINN

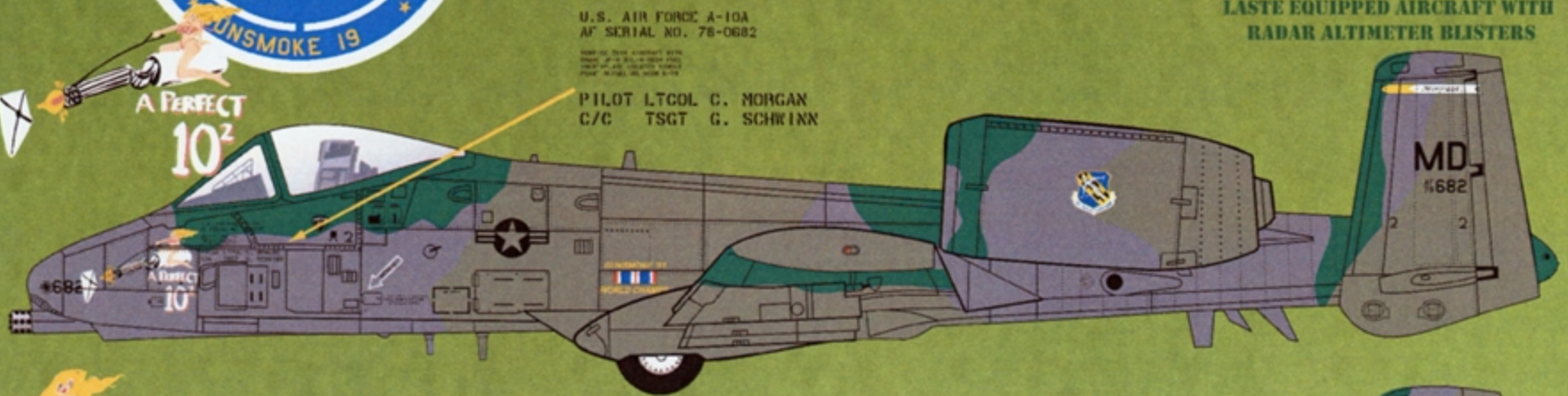

The Professor's Pet

U.S. AIR FORCE A-10A  
AF SERIAL NO. 78-0719

PILOT LTCOL R. HONEY  
C/C SSGT P. BAURICH

MD A-10S CONTINUED TO CARRY THE GUNSMOKE TITLING THROUGH THE LATE 1990S. THE SCRIPT CHANGED FROM YELLOW TO BLACK AND THE OUA HAD A SINGLE OAK LEAF IN THE CENTER.



GUNSMOKE '91  
WORLD CHAMPS

Iron Maiden IV

U.S. AIR FORCE A-10A  
AF SERIAL NO. 78-0693

PILOT LTCOL R. BALL  
C/C SSGT R. KROL

BOTH SIDES

LASTE EQUIPPED AIRCRAFT WITH RADAR ALTIMETER BLISTERS



GUNSMOKE '91  
WORLD CHAMPS

F-Six... what?

U.S. AIR FORCE A-10A  
AF SERIAL NO. 78-0705

PILOT CAPT B. BARNES  
C/C SSGT D. WATERS

U.S. AIR FORCE A-10A  
AF SERIAL NO. 78-0704

PILOT CAPT D. RAND  
C/C TSGT N. BALLARD

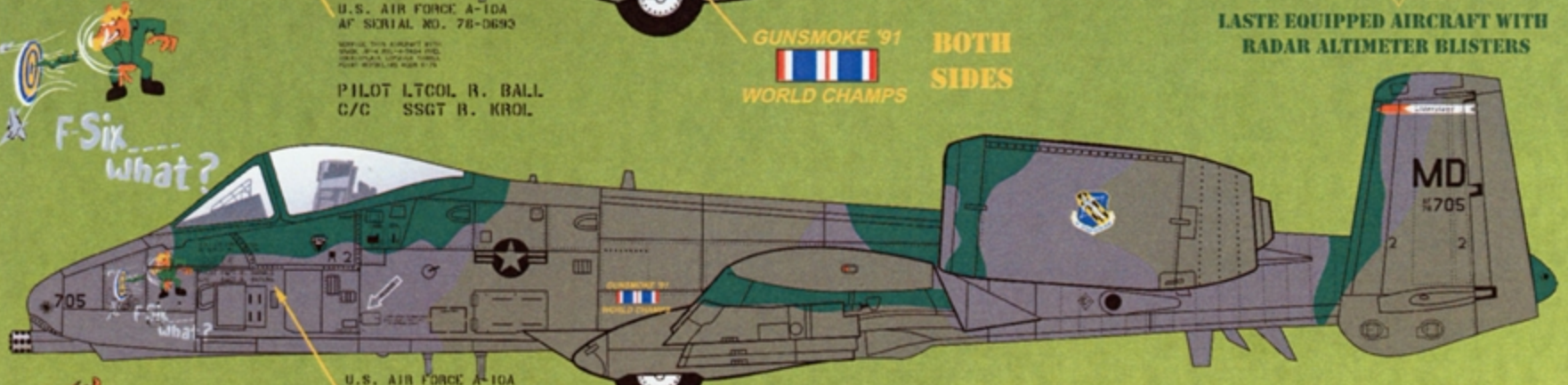
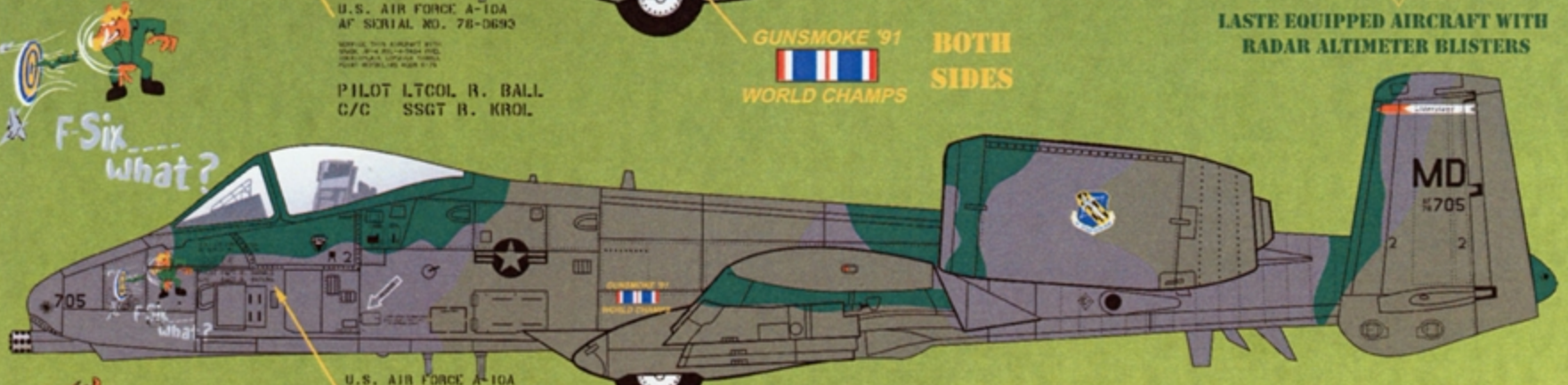

THE INCREDIBLE HOG



INTERIOR  
LEFT  
VERTICAL  
STABILIZER

### NOTES ON UNSMOKED '91 AIRCRAFT

THESE A/C WERE KEPT IN PRISTINE SHAPE. ONCE WE DETERMINED WHICH JETS WE WERE TAKING OUT WEST, WE HAD THEM PAINTED RIGHT BEFORE WE LEFT. ALSO WHILE WE WERE AT DAVIS MONTHAN FOR OUR SPIN UP WE WASHED THEM RIGHT BEFORE WE LEFT (THEY WERE FUN 15+ HOUR DAYS!!)

THE A/C WERE LASTE BUT NOT EGI SO THEY HAD THE TAIL ANTENNA'S BUT NOT THE GPS ANTENNA ON THE SPINE.  
THE NOSE ART WAS APPLIED THE DAY AFTER THE LAST DAY OF FLYING AND AFTER WE FOUND OUT WE HAD WON. THE PILOTS HIRED THE CARICATURE ARTIST FROM THE EXCALIBUR TO PAINT THE JETS. I HAD BOUGHT A BOOK ON NOSE ART AT THE TUCSON MALL DURING THE DM SPIN UP AND WE ADAPTED SOME OF THE IDEAS FROM THE BOOK AND USED THEM ON THE JETS. ONE THING THAT WAS PRETTY NEAT WAS THAT OUR JETS WERE PARKED SO THAT THE RIGHT SIDE OF THE FUSELAGE FACED THE ROAD ON THE FLIGHT LINE, SO WE GOT PERMISSION AND AFTER EACH JET WAS PAINTED WE TOWED IT 180° SO THAT THE NOSE ART WOULD SEEN FROM THE ROAD!! A LOT OF CARS AND TRUCKS STOPPED INCLUDING THE ONES WITH THE WHITE PAINTED ROOFS ( COLS AND GENERALS) THEY ALL LIKED IT EXCEPT THE F-16 GUYS WHO WERE EMBARRASSED THAT A LOWLY A-10 BEAT THEM!!  
-MSGT CRAIG BAUMER

### NOTES ON SENTRY INDEPENDENCE '89 AIRCRAFT

THESE JETS WERE DONE UP DURING AN EXERCISE IN 1989 AT TRUAX WI, THIS EXERCISE STARTED THE NOSE ART "CRAZE" AS THEY WERE AWAY FROM ADULT SUPERVISION, THAT IS NOBODY HIGHER THAN A MAJOR WAS THERE SO THEY KINDA DID WHAT THEY WANTED.  
-MSGT CRAIG BAUMER

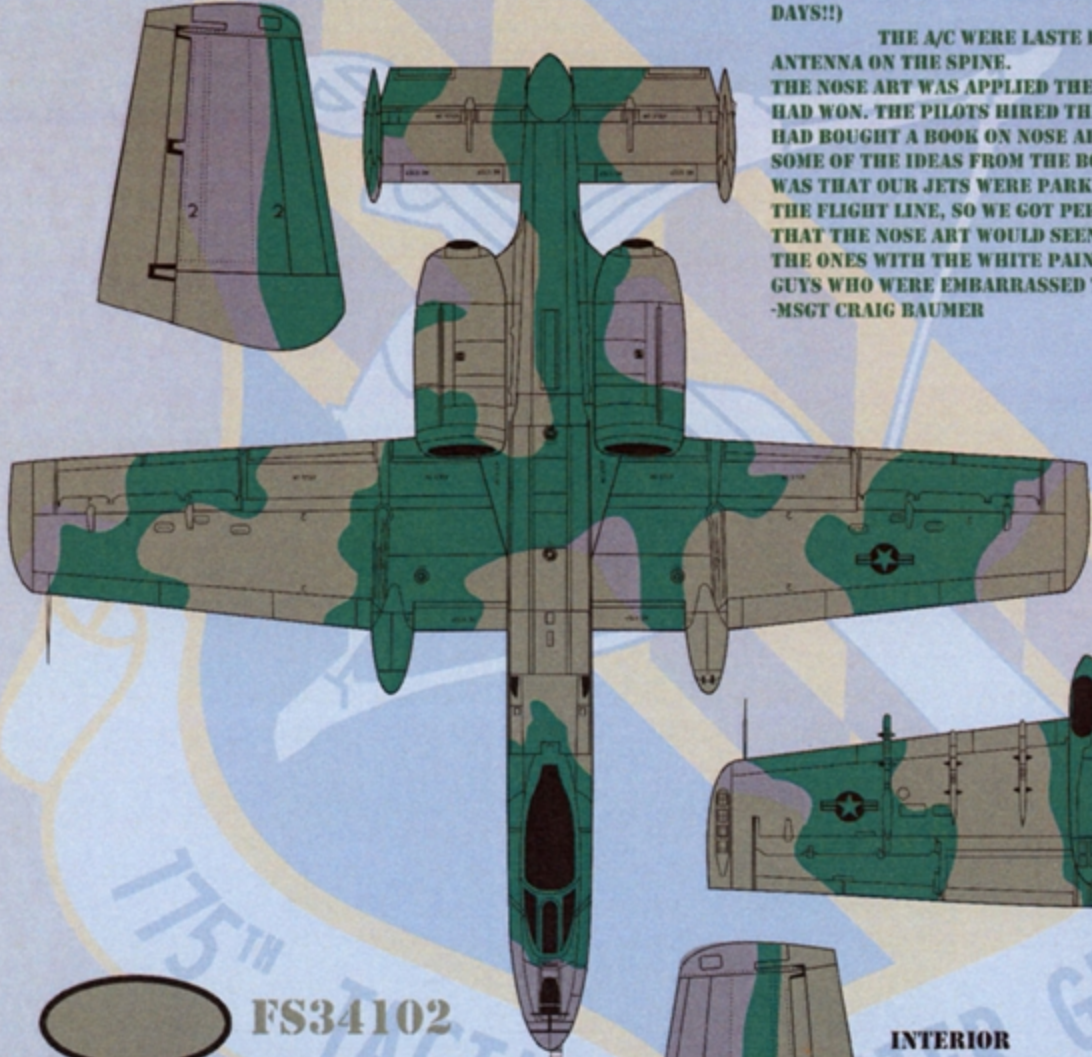

-  FS34102
-  FS34092
-  FS36081

INTERIOR  
RIGHT  
VERTICAL  
STABILIZER



USE IN CONJUNCTION WITH BLACK VINYL A-10 INTAKE COVERS MANUFACTURED BY STEEL BEACH AND AVAILABLE FROM WWW.SPRUEBROTHERS.COM

## 1990 OPERATIONAL READINESS INSPECTION

CONDITION  
RED  
MY A-10S  
REMEMBER !!!

U.S. AIR FORCE A-10A  
AF SERIAL NO. 79-0086  
PILOT COL. B. TULL  
G/C SSGT P. BAUMER  
A/C/SRA D. PEARSON

175TH TACTICAL FIGHTER GROUP  
BADGE  
PLACEMENT ON LEFT NACELLE COMMON TO  
EURO I SCHEMED AIRCRAFT.



104TH FIGHTER SQUADRON  
BADGE  
PLACEMENT ON RIGHT NACELLE IS  
COMMON TO ALL AIRCRAFT.



# 104TH FIGHTER SQUADRON A-10C 2009



PILOT: CAPT JEFF DUPREZ  
CC: SRA NATALIE JONES  
ACC: SRA JOHN PERRY

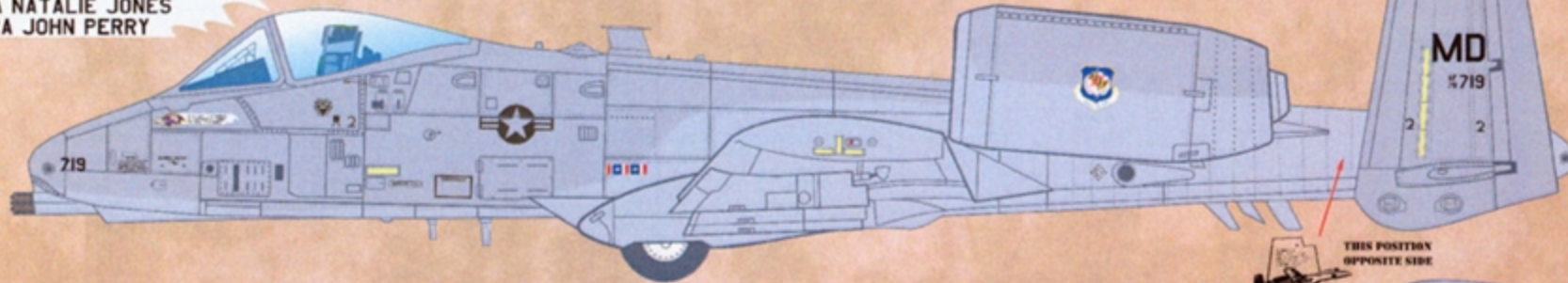

LADDER DOOR ART



PILOT: LT COL JAY HEDLEY  
CC: MSGT STEVE THOMAS  
ACC:

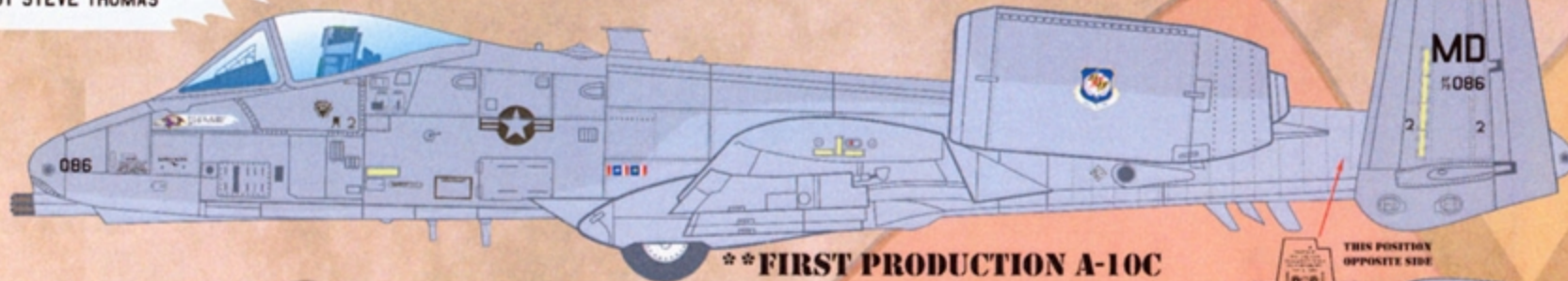

LADDER DOOR ART

\*\*FIRST PRODUCTION A-10C



PILOT: LT COL PAUL JOHNSON  
CC: SSGT MIKE GILLIS  
ACC: SRA ANTHONY MURRAY

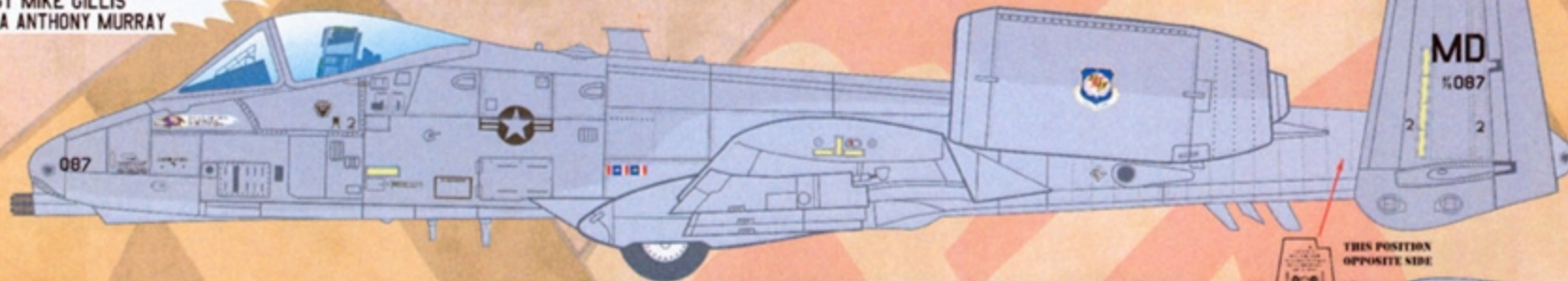

LADDER DOOR ART



PILOT: MAJ TODD ANTHONY  
CC: TSGT DAVE LINDER  
ACC:

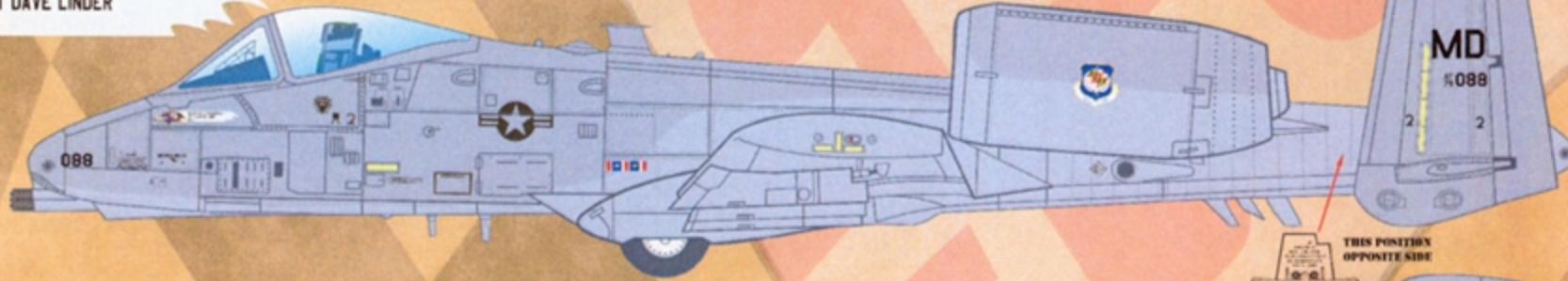

LADDER DOOR ART



PILOT: LTCOL MCALISTER  
CC: TSGT SHAWN KENNEDY  
ACC: SRA NOAH THOMAS

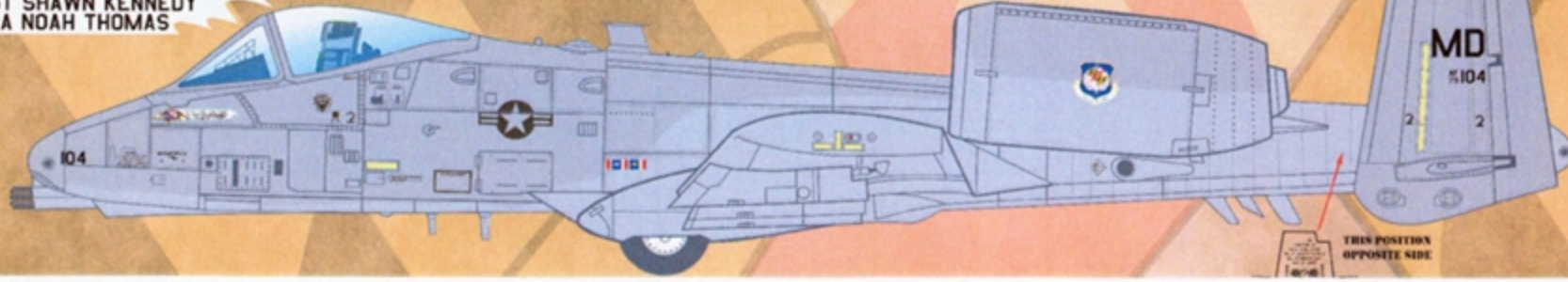

LADDER DOOR ART

# 104TH FIGHTER SQUADRON A-10C 2009



PILOT: BG GUY WALSH  
CC: MSGT CRAIG BAUMER  
ACC: TSGT JASON DOERFLIEN

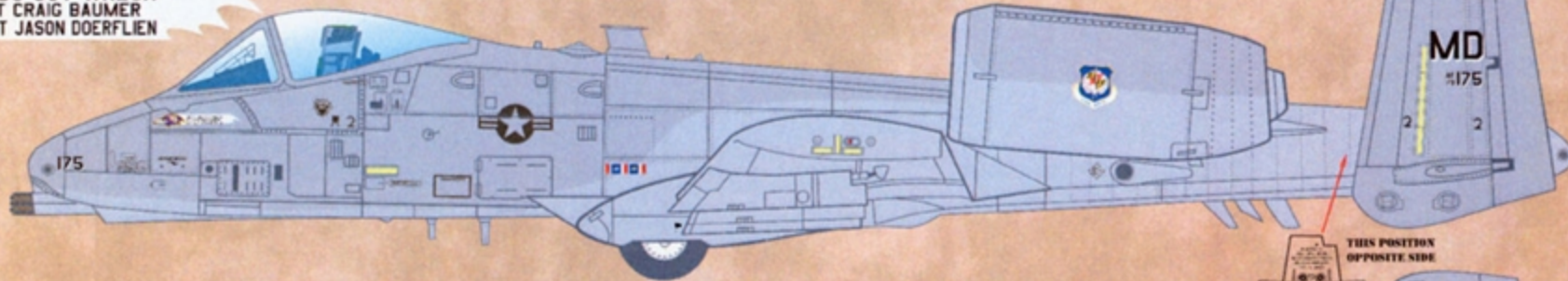

LADDER DOOR ART



PILOT: CAPT CHRIS LAKE  
CC: SSGT JUSTIN ELLIOT  
ACC:

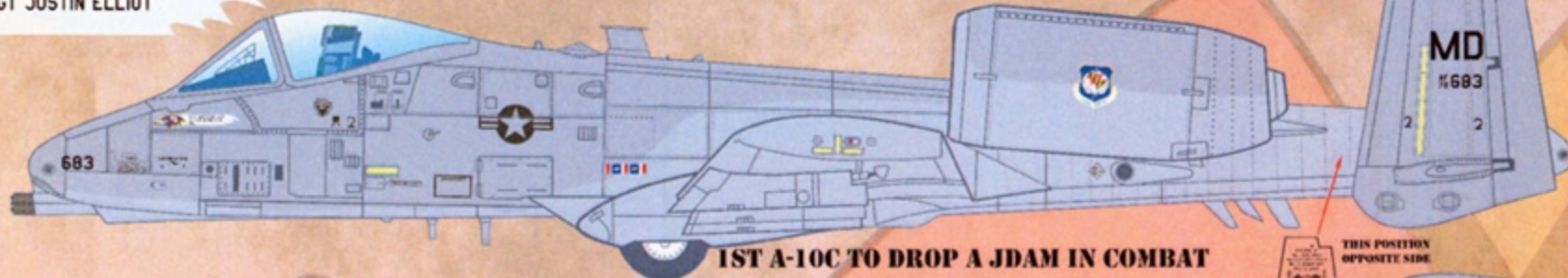

1ST A-10C TO DROP A JDAM IN COMBAT



LADDER DOOR ART



PILOT: MAJ ERIC MURPHY  
CC: SSGT CARL MACHADO  
ACC: SRA DANIEL KELLEY

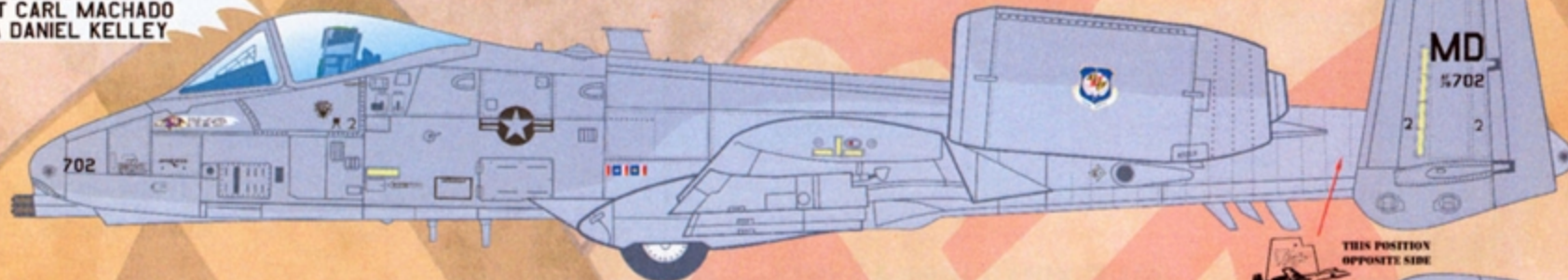

LADDER DOOR ART



PILOT: LT COL KEN O'NEIL  
CC:  
ACC:

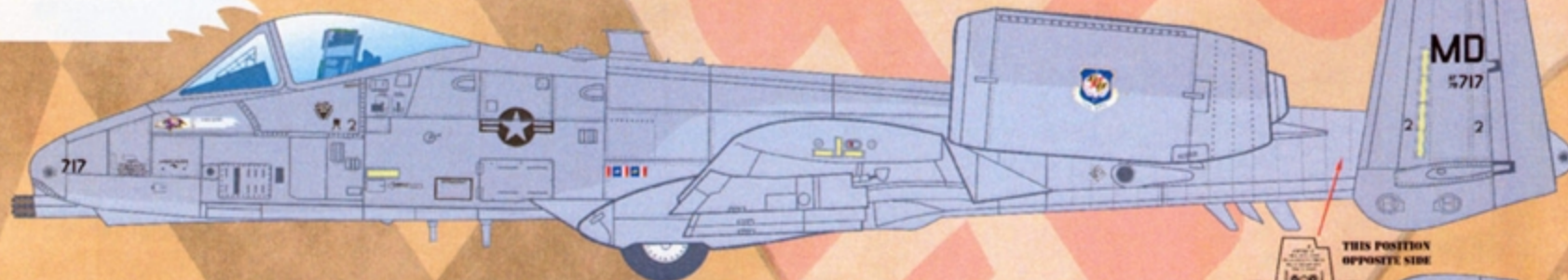

LADDER DOOR ART



PILOT: LT COL KEVIN CAMPBELL  
CC: TSGT ANTONIO QUEEN  
ACC:

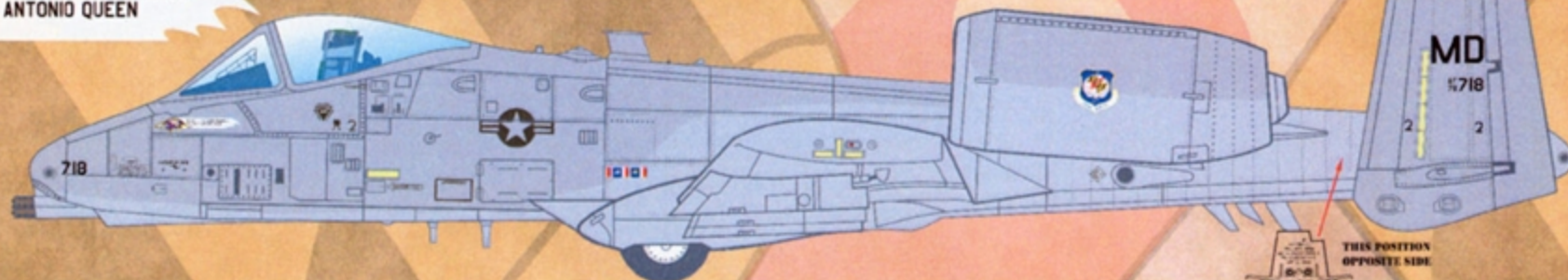

LADDER DOOR ART

# A-10A 175TH WING CO 2000

PILOT: COL DAVE "TANK" TANKARA  
 CC: TSGT PHILP "BOOMER" BAUMER  
 ACC: SSGT HERMAN CRAIG

NO GPS DOME

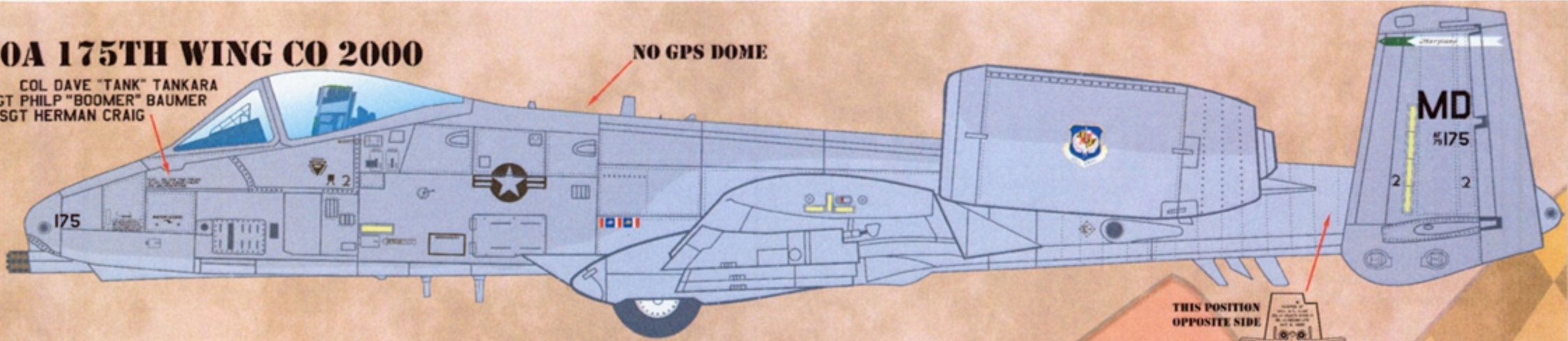

# A-10A "COYOTE KILLER" 2005

PILOT: LT COL JAMES COOLAHAN  
 CC: MSGT ROBERT TOWNSEND  
 ACC: SRA KEENAN BOES



## 2009 CREWS

PILOT: LT COL JAMES COOLAHAN  
 CC: MSGT ROBERT TOWNSEND  
 ACC: SRA JASON MATS

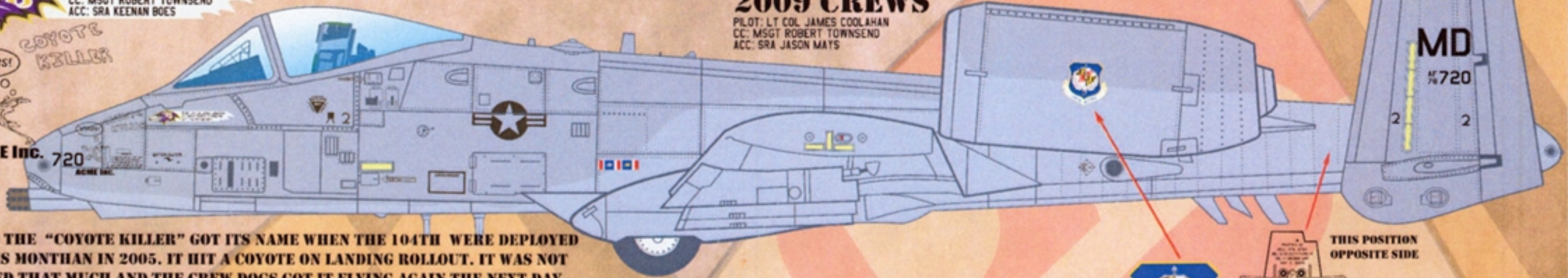

78-0720 THE "COYOTE KILLER" GOT ITS NAME WHEN THE 104TH WERE DEPLOYED TO DAVIS MONTHAN IN 2005. IT HIT A COYOTE ON LANDING ROLLOUT. IT WAS NOT DAMAGED THAT MUCH AND THE CREW DOGS GOT IT FLYING AGAIN THE NEXT DAY. THE COYOTE WASN'T AS FORTUNATE.

104TH FIGHTER SQUADRON BADGE  
 PLACEMENT ON RIGHT NACELE IS  
 COMMON TO ALL AIRCRAFT.

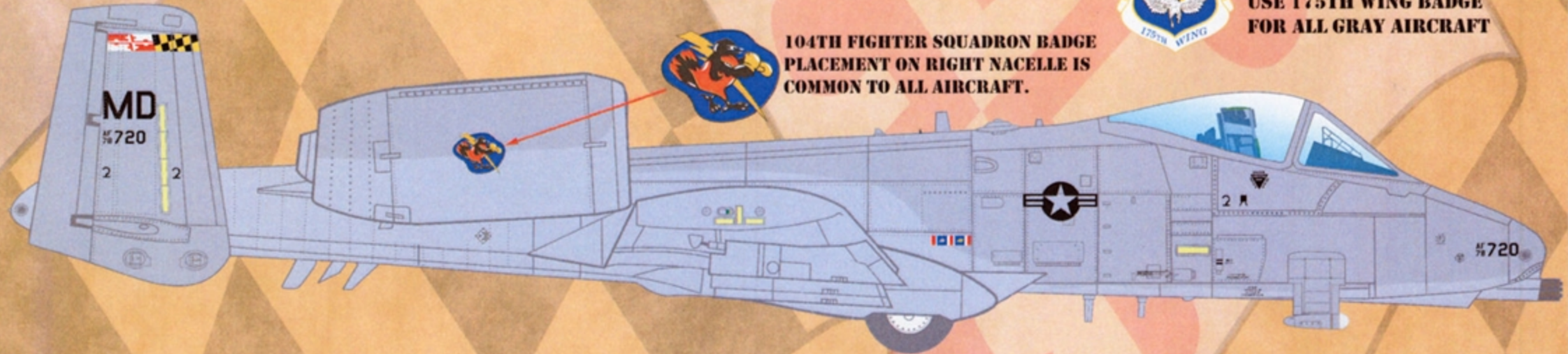

USE 175TH WING BADGE  
 FOR ALL GRAY AIRCRAFT

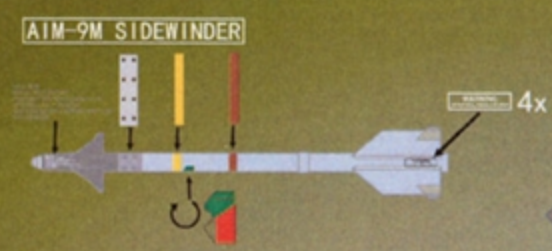

-  LIGHT GHOST GRAY  
FS 36375
-  DARK GHOST GRAY  
FS 36320
-  GUNSHIP GRAY  
FS 36118
-  OLIVE DRAB  
FS 34087

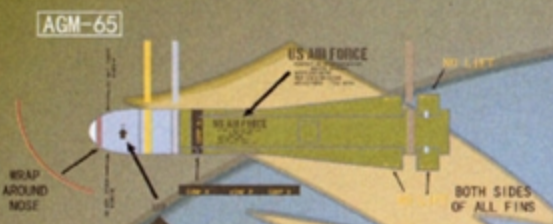

AN/ALQ-131 THREE BAND



OLD STYLE INTAKE COVER

NEW STYLE INTAKE PLUG  
EACH AIRCRAFT HAS ITS OWN SET THAT CORRESPONDS WITH TAIL NUMBERS





# STENCIL PLACEMENT

## SPECIAL THANKS!



**MSGT CRAIG BAUMER  
LT COL RON HENRY  
SMSGT JOE BONNER  
ALEC FUSHI  
GEORGE SALERNO  
JAKE MELAMPY  
JEFF PASTERIS**

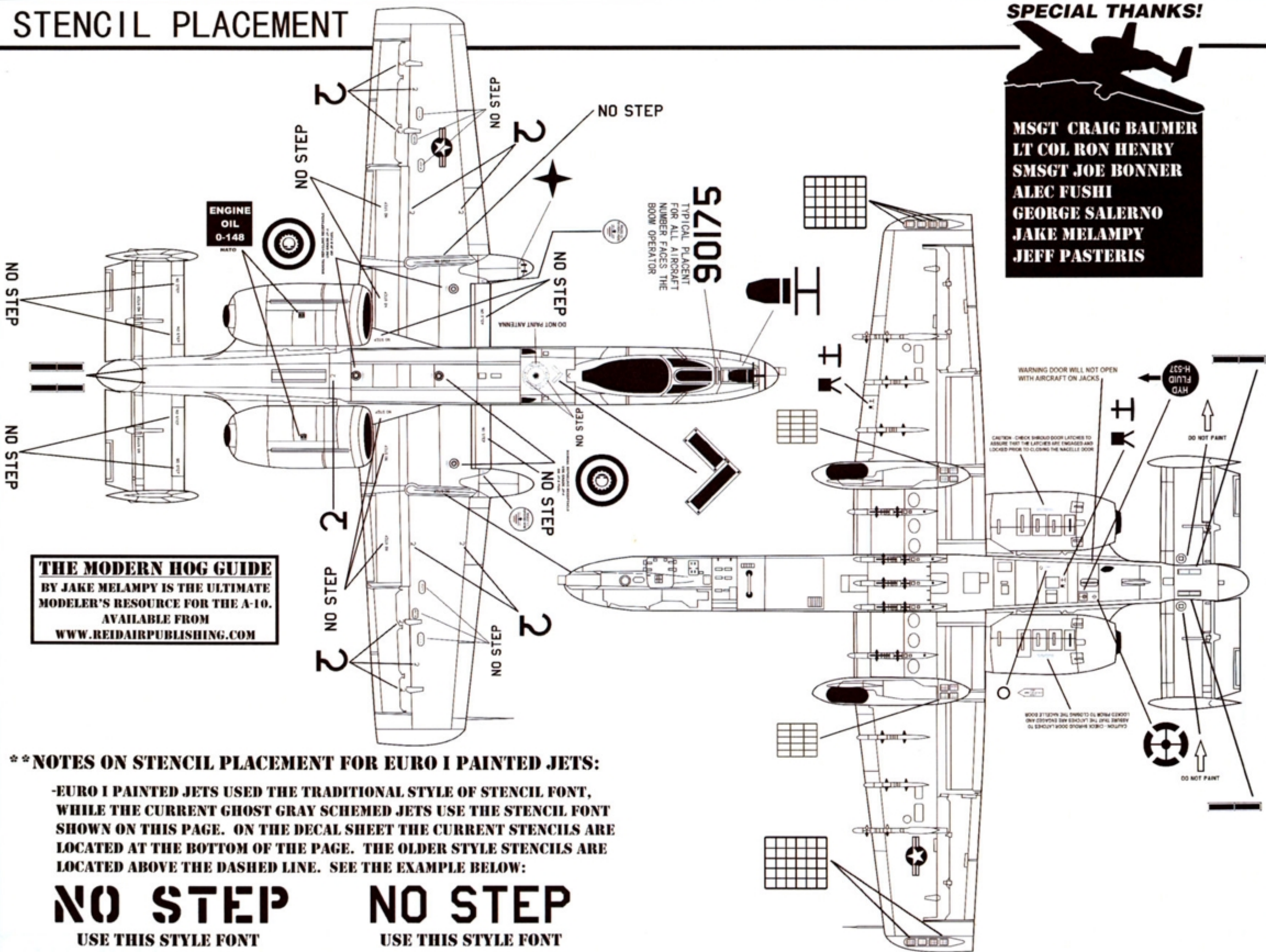

**THE MODERN HOG GUIDE**  
BY JAKE MELAMPY IS THE ULTIMATE  
MODELER'S RESOURCE FOR THE A-10.  
AVAILABLE FROM  
[WWW.REIDAIRPUBLISHING.COM](http://WWW.REIDAIRPUBLISHING.COM)

### \*\* NOTES ON STENCIL PLACEMENT FOR EURO I PAINTED JETS:

-EURO I PAINTED JETS USED THE TRADITIONAL STYLE OF STENCIL FONT, WHILE THE CURRENT GHOST GRAY SCHEMED JETS USE THE STENCIL FONT SHOWN ON THIS PAGE. ON THE DECAL SHEET THE CURRENT STENCILS ARE LOCATED AT THE BOTTOM OF THE PAGE. THE OLDER STYLE STENCILS ARE LOCATED ABOVE THE DASHED LINE. SEE THE EXAMPLE BELOW:

**NO STEP**  
USE THIS STYLE FONT  
FOR EURO I JETS

**NO STEP**  
USE THIS STYLE FONT  
FOR GHOST GRAY JETS

# STENCIL PLACEMENT

EACH AIRCRAFT HAS IT  
TAIL NUMBER PAINTED ON  
THE CANOPY FRAME. 10991

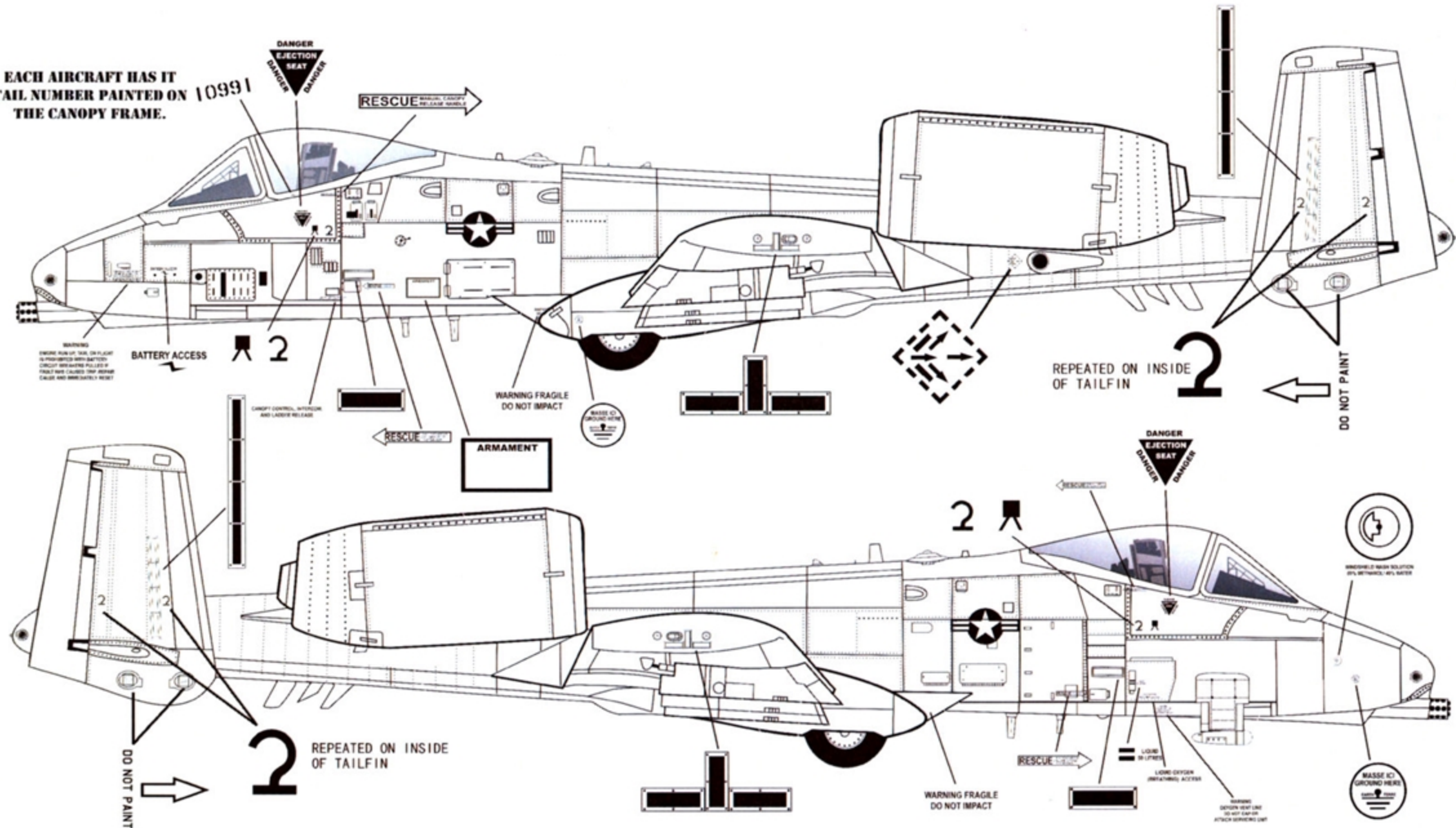

STATIONS 1/11



STATIONS 3/9 LEFT



STATIONS 5/7



STATIONS 2/10



STATIONS 4/8



STATION 6



CAUTION

RESCUE

RESCUE

RESCUE

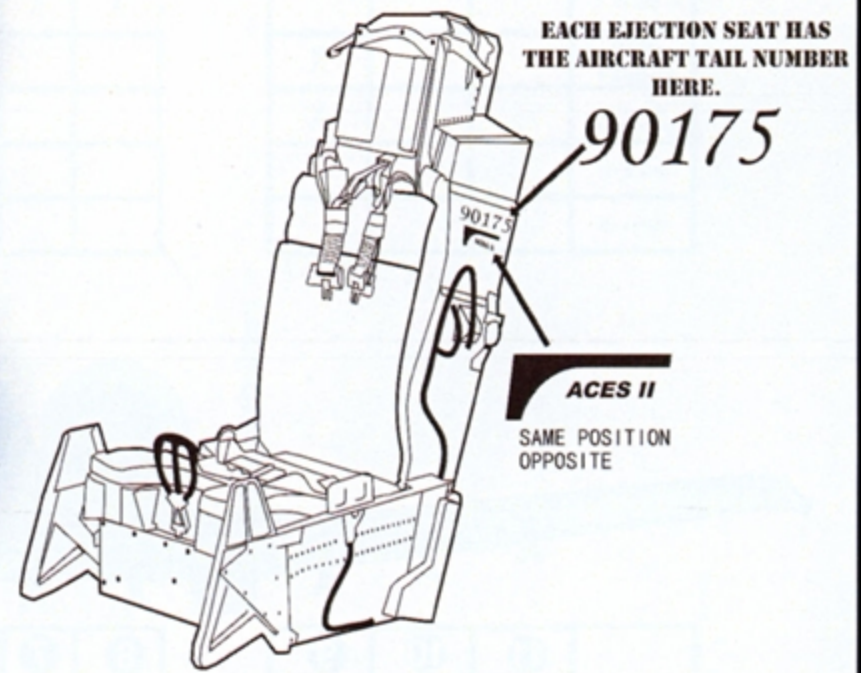
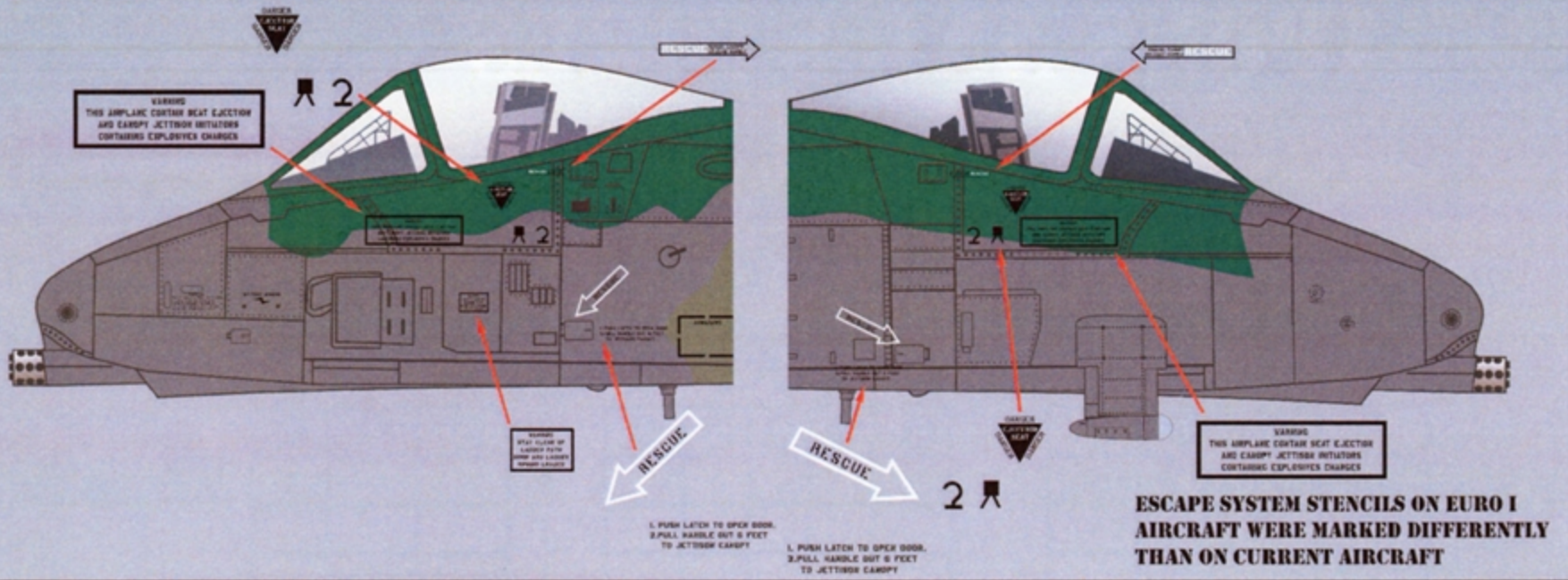

**DUE TO SPACE CONSIDERATIONS, NOT ALL OF THE 2009 AIRCRAFT ON THIS SHEET COULD BE REPRESENTED IN PROFILE. THE CHARTS BELOW SHOW THE PERTINENT INFORMATION SPECIFIC TO EACH AIRCRAFT. ALL AIRCRAFT HAVE BEEN UPGRADED TO THE A-10C CONFIGURATION, AND ALSO HAVE THE SATCOM ANTENNA INSTALLED ON THE SPINE BEHIND THE GPS DOME.**

PILOT: MAJ RICHARD HUNT CC: SSGT MIKE DEZINNA ACC: SRA JOSEPH MCKEAGUE <b>AF 78 612</b> **FORMER 104TH FIGHTER WING JET	PILOT: MAJ PAUL ZURKOWSKI CC: TSGT JEREMY STEEL ACC: <b>AF 78 682</b>	PILOT: LT COL RICK DAVISON CC: TSGT SHAWN KENNEDY ACC: SRA CHRIS O'HARA <b>AF 78 704</b>	PILOT: COL SCOTT KELLY CC: TSGT DAVE YARBOROUGH ACC: SRA BEN SMITH <b>AF 79 082</b>
PILOT: MAJ ROB BRAWLEY CC: TSGT JOE SEDLOCK ACC: SRA JEFF SEIDENZAHL <b>AF 78 637</b>	PILOT: LT COL ED JONES CC: SSGT SHAUN SPURLIN ACC: TSGT JASON DOERFLIN <b>AF 78 693</b>	PILOT: LT COL DAN MARINO CC: TSGT ROBERT GRIFFIN ACC: <b>AF 78 705</b>	PILOT: LTCOL RANDOLPH ST AUGERHAUS CC: TSGT DAVE LINDER ACC: <b>AF 79 108</b> **FORMER 103RD FIGHTER WING JET
PILOT: LT COL DOUG BAKER CC: TSGT JEREMY STEEL ACC: <b>AF 78 640</b> **FORMER 104TH FIGHTER WING JET	PILOT: LT COL DAVE DRAPER CC: TSGT JOE SEDLOCK ACC: SRA DEREK TRAGESER <b>AF 78 694</b>	PILOT: LT COL TIM SMITH CC: SSGT BRENT DAY ACC: TSGT JUSTIN BEALL <b>AF 78 719</b>	PILOT: CAPT JOHN HITCHCOCK CC: SSGT ADAM STILES ACC: <b>AF 79 165</b> **FORMER 103RD FIGHTER WING JET

# WEAPONS AND STORES

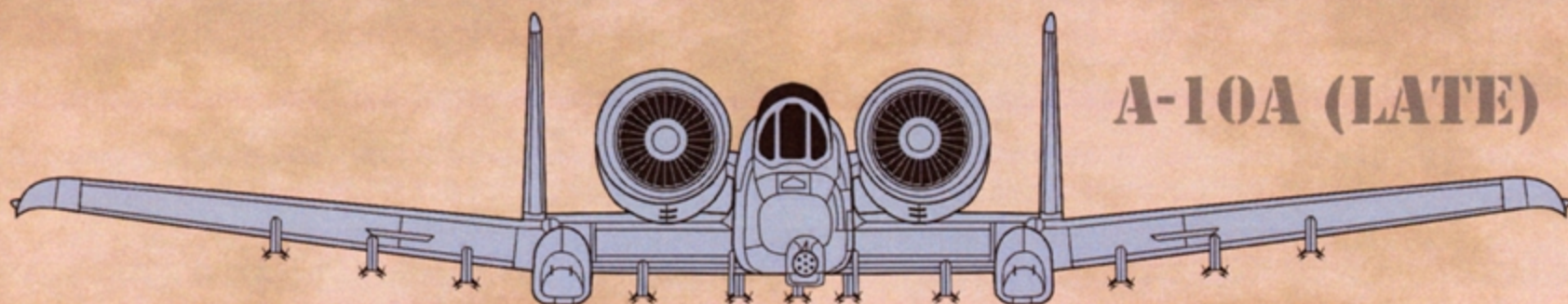

## A-10A (LATE)

	11	10	9
DUAL RAIL ADAPTER + 2 AIR-98	X		
LAU-168/131 ROCKET POD		X	
SUB-25 FLARE DISPENSER		X	
GBU-12 LGB			
WV-82 LOW DRAG GENERAL PURPOSE			
GBU-87			
LAU-117 + AGM-65G/D/K			X
AN/AAQ-28 LISTENING AT			X
AN/ALQ-131			
AN/ALQ-184			

8	7	6	5	4
X	X	X	X	X
X	X	X	X	X
X	X	X	X	X

3	2	1
		X
	X	
	X	
X		
		X
		X

STATION 11 IS MOST COMMONLY USED FOR THE AIM-9 COMBO, HOWEVER STATION 1 CAN BE USED AS WELL

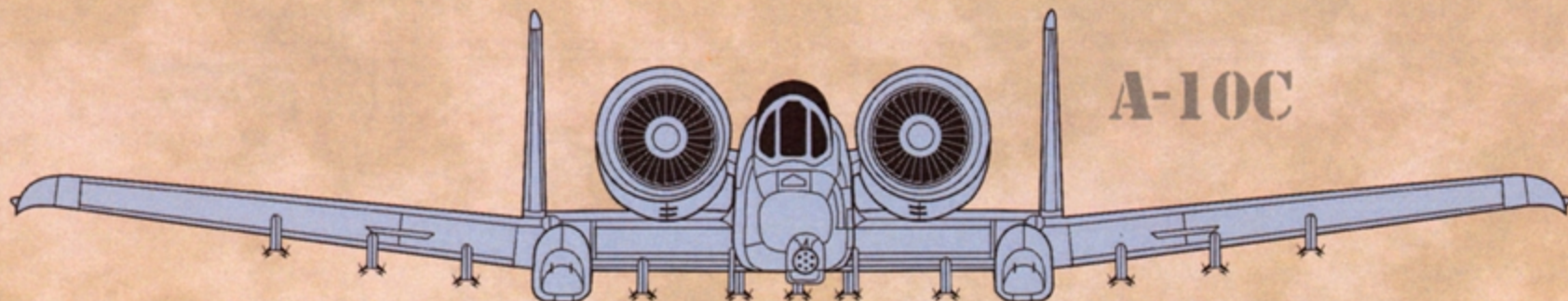

## A-10C

	11	10	9
DUAL RAIL ADAPTER + 2 AIR-98	X		
LAU-168/131 ROCKET POD		X	
SUB-25 FLARE DISPENSER		X	
GBU-12 LGB			
WV-82 LOW DRAG GENERAL PURPOSE			
GBU-38 JCAM			
GBU-87			
WCMD			
LAU-117 + AGM-65G/D/K			X
DBA + AN/ARD-235 FAOL POD	X		
AN/AAQ-28 LISTENING AT		X	
AN/ALQ-144 SNIPER POD		X	
AN/ALQ-131			
AN/ALQ-184			

8	7	6	5	4
X	X	X	X	X
X	X	X	X	X
X	X		X	X
X	X	X	X	X
X	X		X	X

3	2	1
	X	
	X	
X		
		X
		X