

Lysander

1/48

Limited Edition

INSTRUCTION SHEET



eduard

1138_0101



Carefully read instruction sheet before assembling. When you use glue or paint, do not use near open flame and use in well ventilated room. Keep out of reach of small children. Children must not be allowed to suck any part, or pull vinyl bag over the head.



Před započítím stavby si pečlivě prostudujte stavební návod. Při používání barev a lepidel pracujte v dobře větrané místnosti. Lepidla ani barvy nepoužívejte v blízkosti otevřeného ohně. Model není určen malým dětem, mohlo by dojít k požití drobných dílů.

INSTRUCTION SIGNS * INSTR. SYMBOLY * INSTRUKTION SINNBILDEN * SYMBOLES * 記号の説明



OPTIONAL
VOLBA



BEND
OHNOUT



SAND
BROUSIT



OPEN HOLE
VYVRTAT OTVOR



SYMMETRICAL ASSEMBLY
SYMETRICKÁ MONTÁŽ



REMOVE
ODRŽNOUT



REVERSE SIDE
OTOČIT



APPLY EDUARD MASK
AND PAINT
POUŽIT EDUARD MASK
NABARVIT

PARTS



DÍLY



TEILE



PIÈCES



部品

PLASTIC PARTS

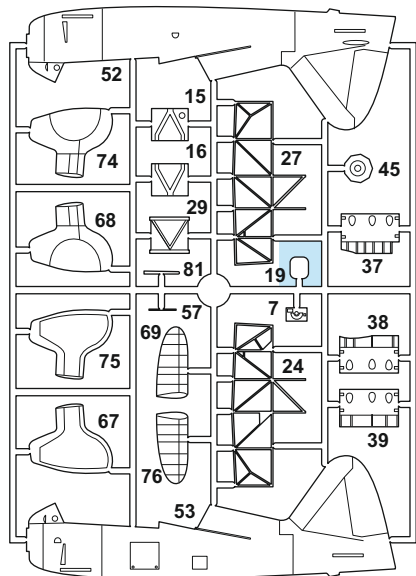
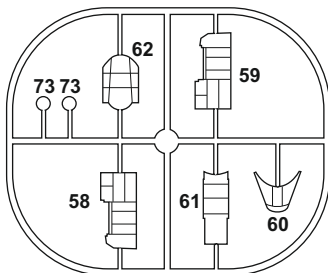
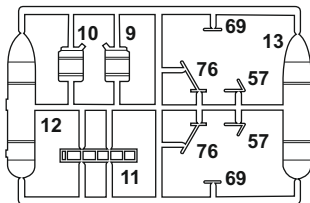
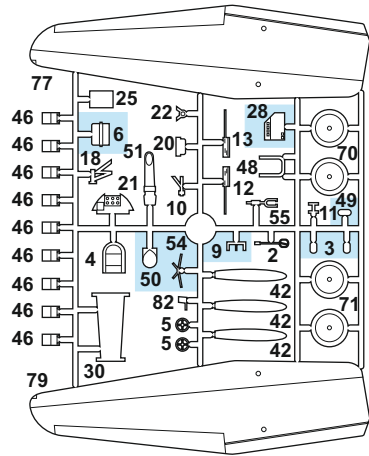
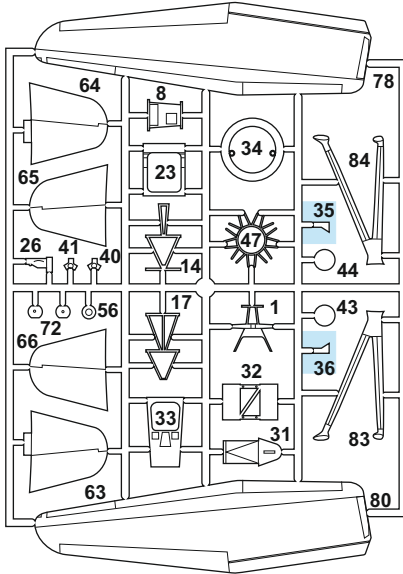

-Parts not for use. -Teile werden nicht verwendet. -Pièces à ne pas utiliser. -Tyto díly nepoužívejte při stavbě. - 使用しない部品



RP - RESIN PARTS

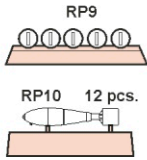
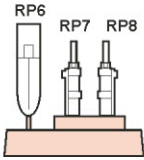
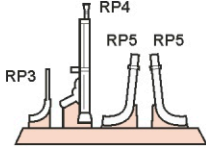

PE - PHOTO ETCHED DETAIL PARTS

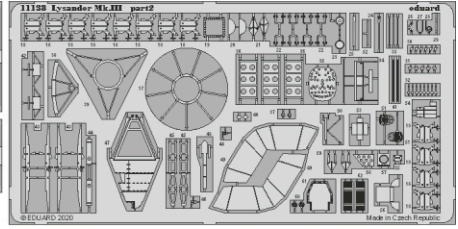

eduard
MASK

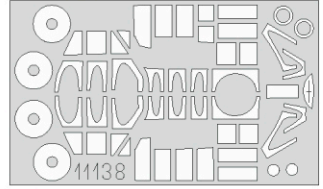

FILM

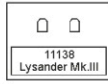

COLOURS * BARVY * FARBEN * PEINTURE * 色

GSI Colors (GUNZE)		MISSION MODELS	
AQUEOUS	Mr.COLOR	PAINTS	
H4	C4	MMP-007	YELLOW
H6	C8		SILVER
H11	C62	MMP-001	FLAT WHITE
H12	C33	MMP-047	FLAT BLACK
H47	C41	MMP-012	RED BROWN
H58	C351	MMP-059	INTERIOR GREEN
H67	C115	MMP-057	LIGHT BLUE
H72	C369	MMP-078	DARK EARTH
H74	C368	MMP-080	SKY
H77	C137	MMP-040	TIRE BLACK
H78	C38		OLIVE GREEN

GSI Colors (GUNZE)		MISSION MODELS	
AQUEOUS	Mr.COLOR	PAINTS	
H318	C318	MMP-070	RADOME
H330	C361	MMP-077	DARK GREEN
H335	C363	MMP-094	MEDIUM SEAGRAY
H413	C113	MMP-090	YELLOW
Mr.METAL COLOR		METALLICS	
MC214		MMM-001	DARK IRON
MC216			BRONZE
MC218		MMM-003	ALUMINIUM
MC219		MMM-009	BRASS
Mr.COLOR SUPER METALLIC		METALLICS	
SM206		MMC-001	SUPER CHROME SILVER

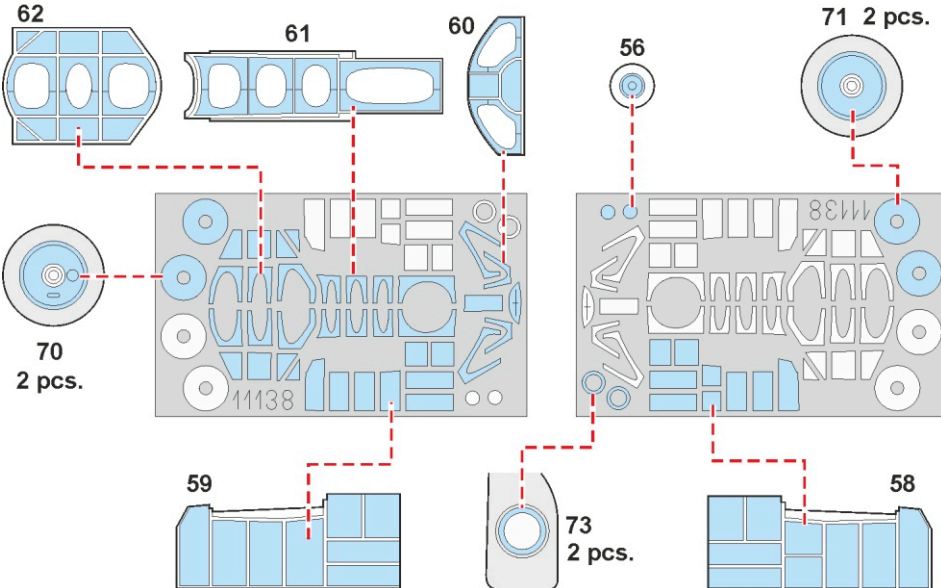

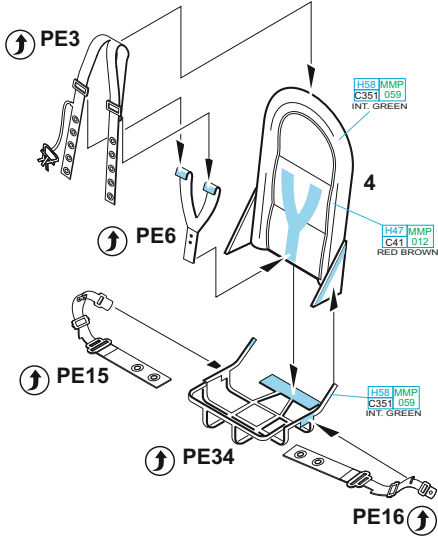
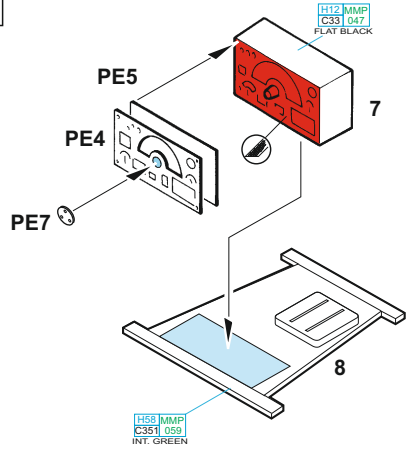
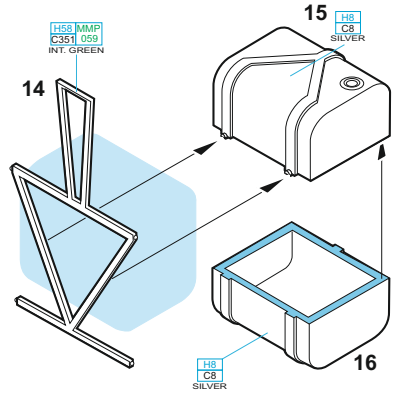
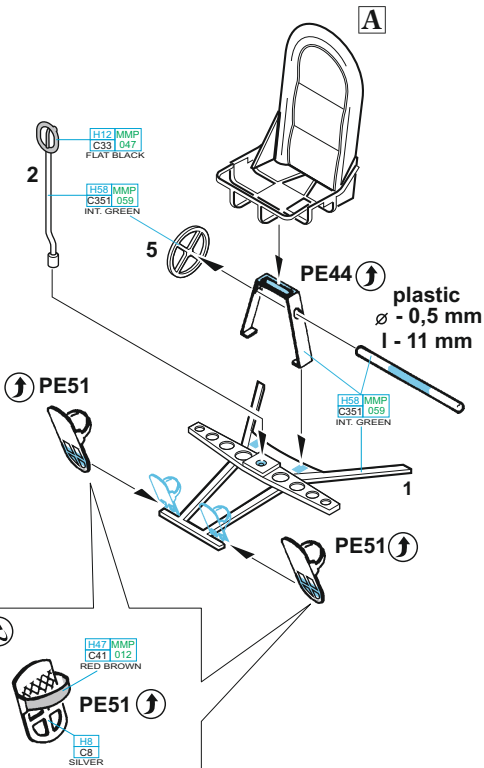
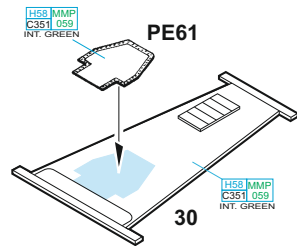
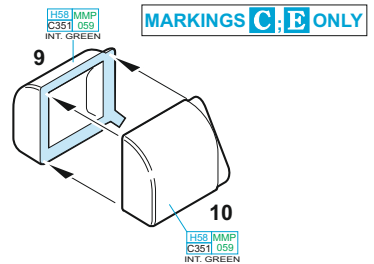
A**B****C****D****E****F** (?)

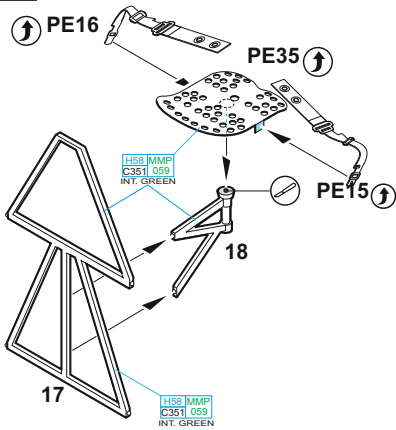
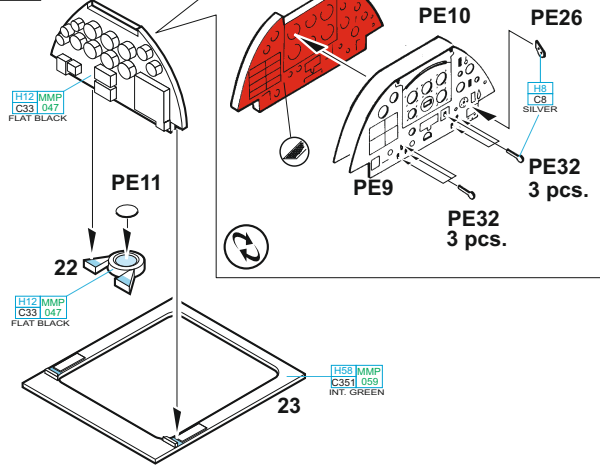
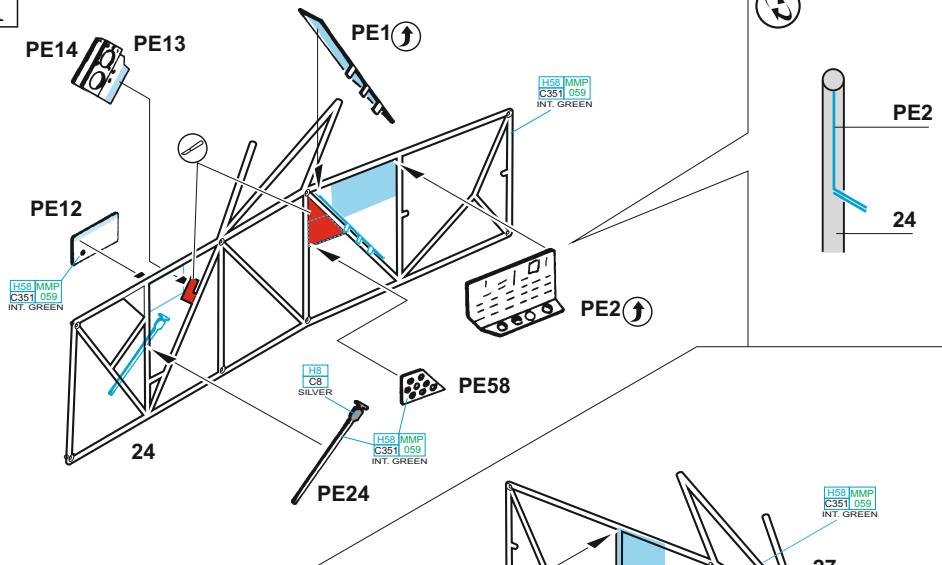
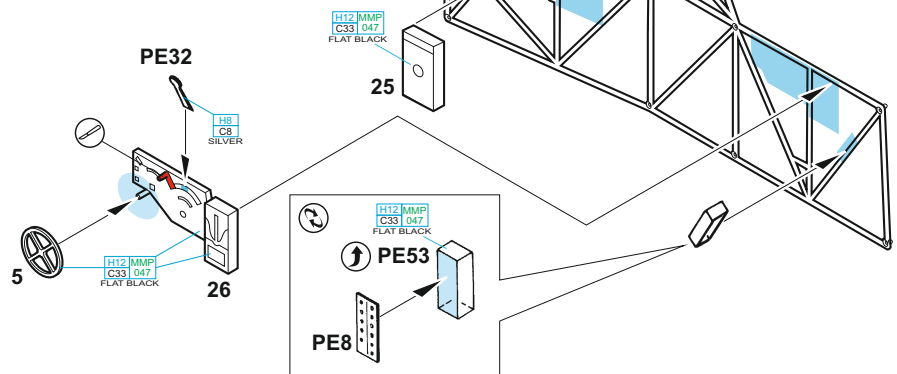
G**H****I****J**

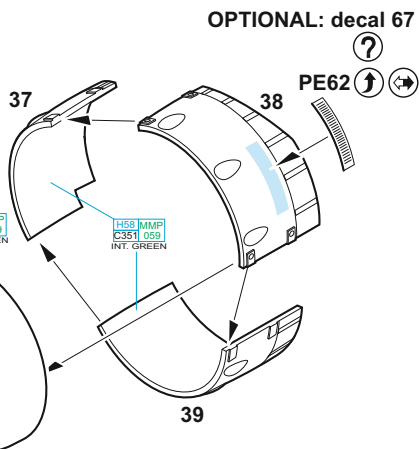
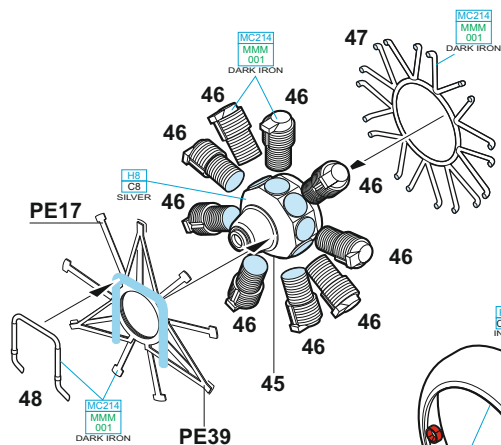
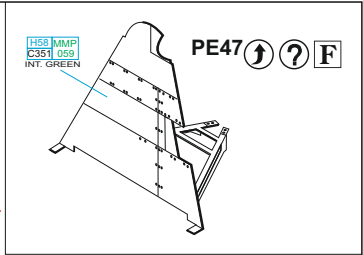
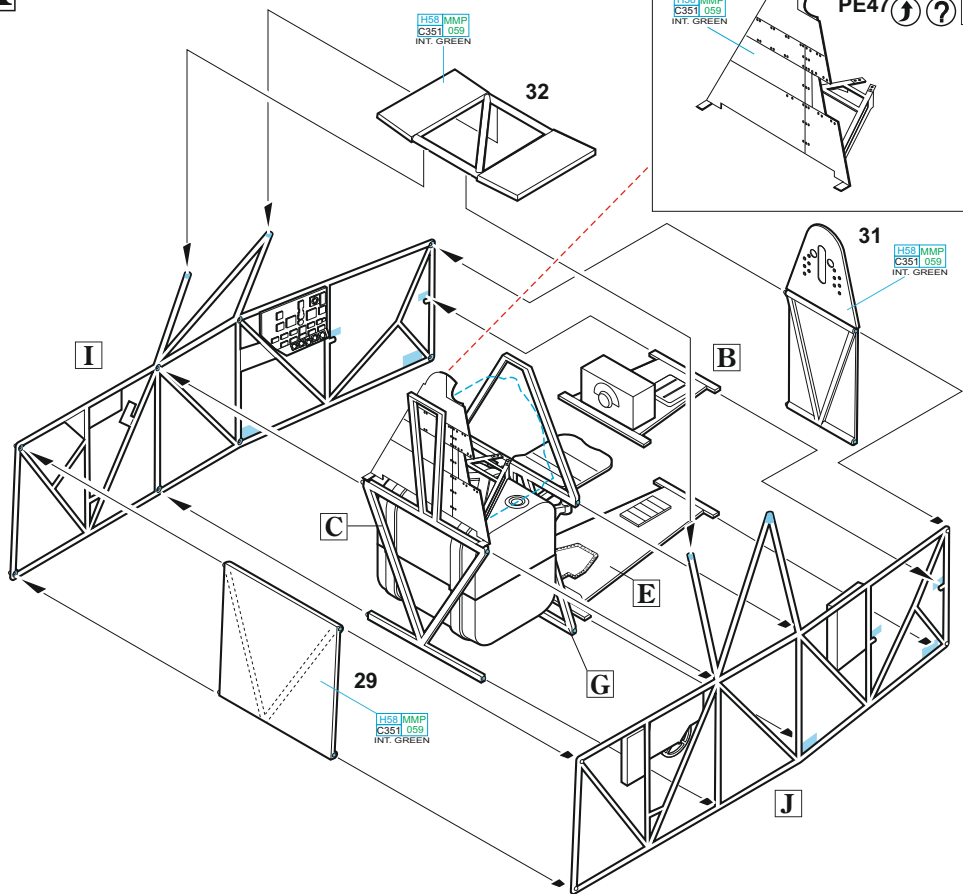
K

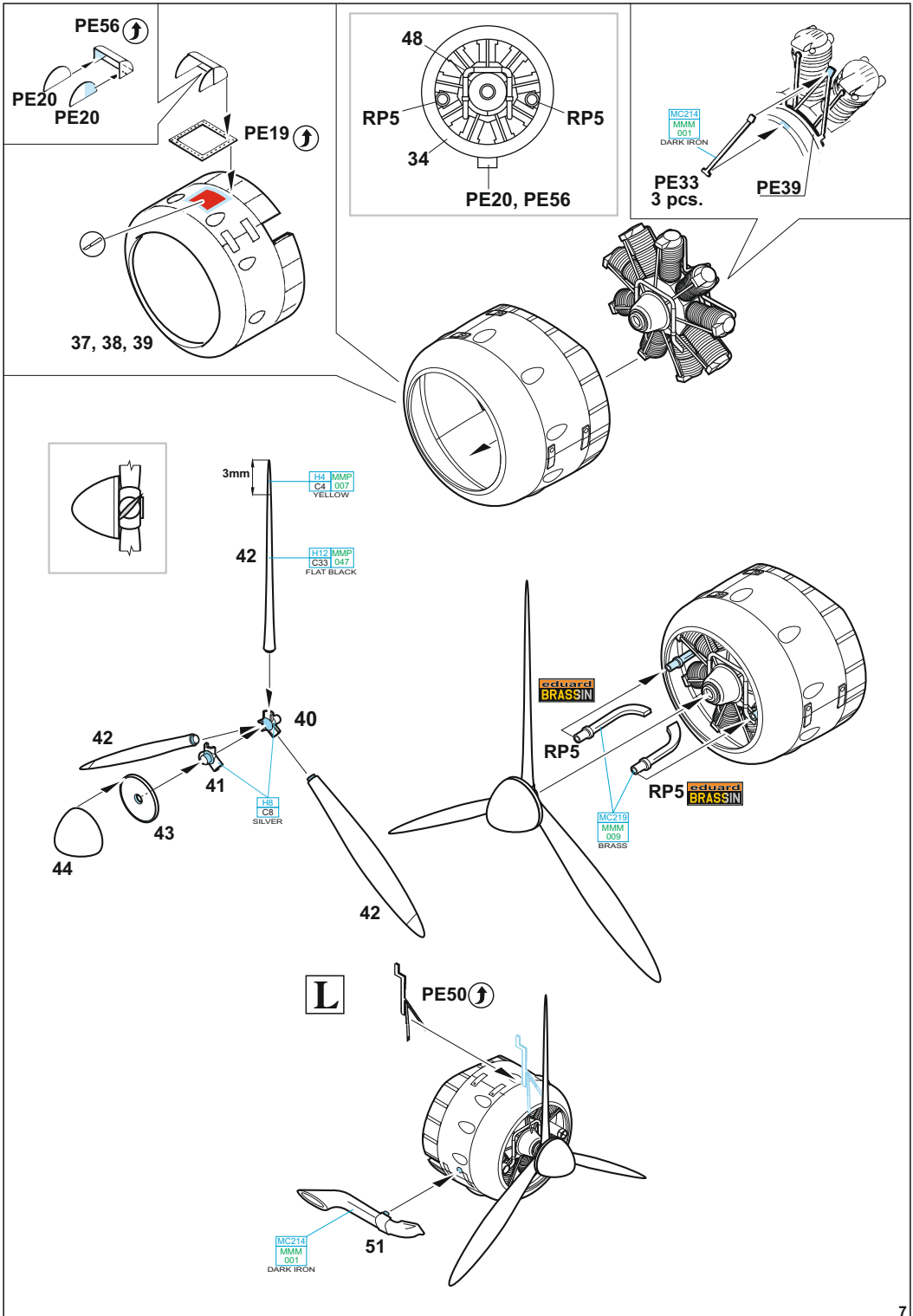

PE63 ↗

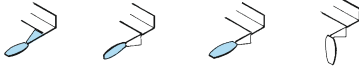

MARKINGS **A, B, F, G** ONLY

MARKING **D** ONLY

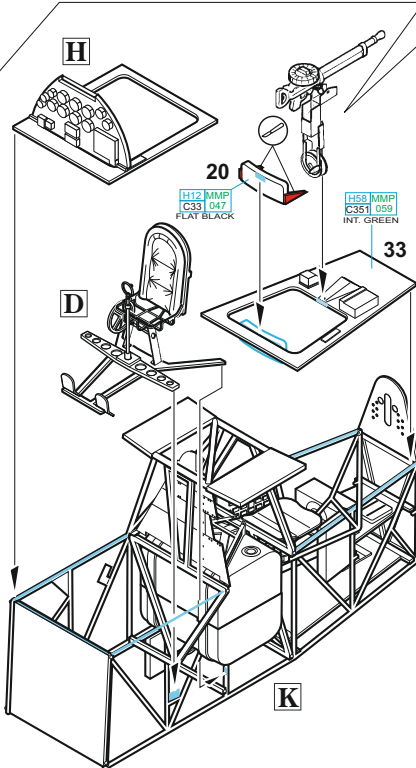
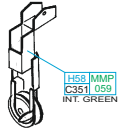
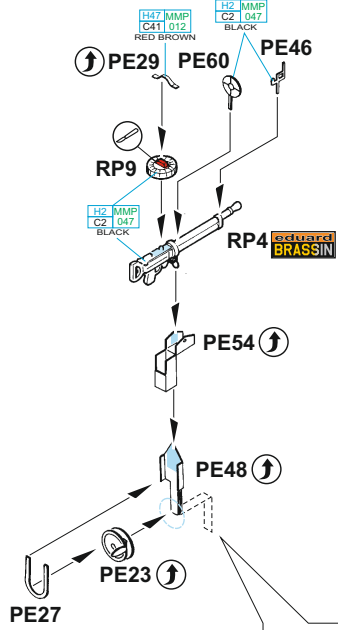
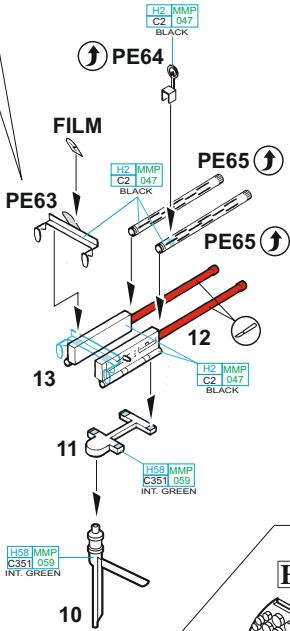

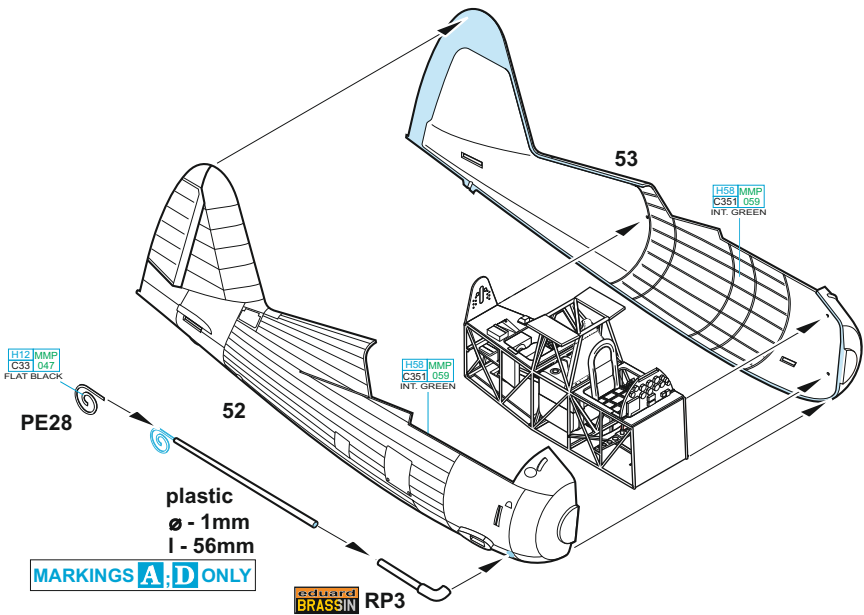

M ? 3 pcs.

MARKINGS A; B; D; G ONLY

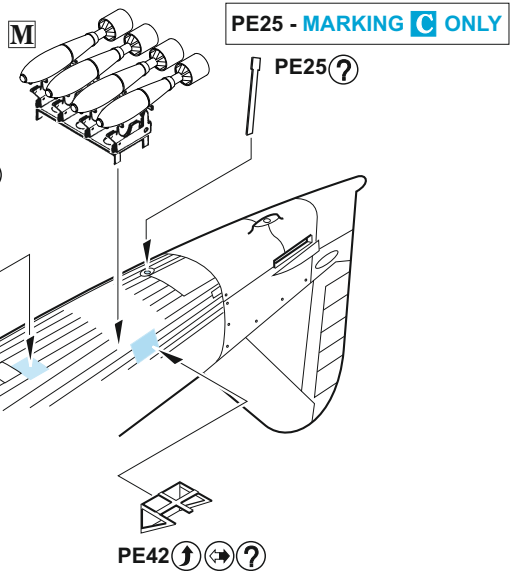
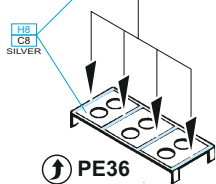
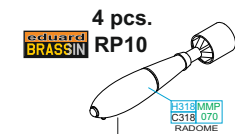

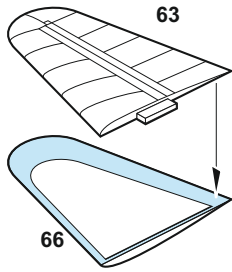
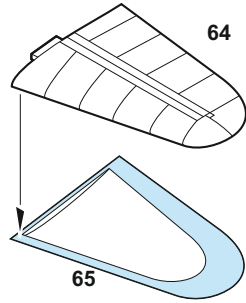
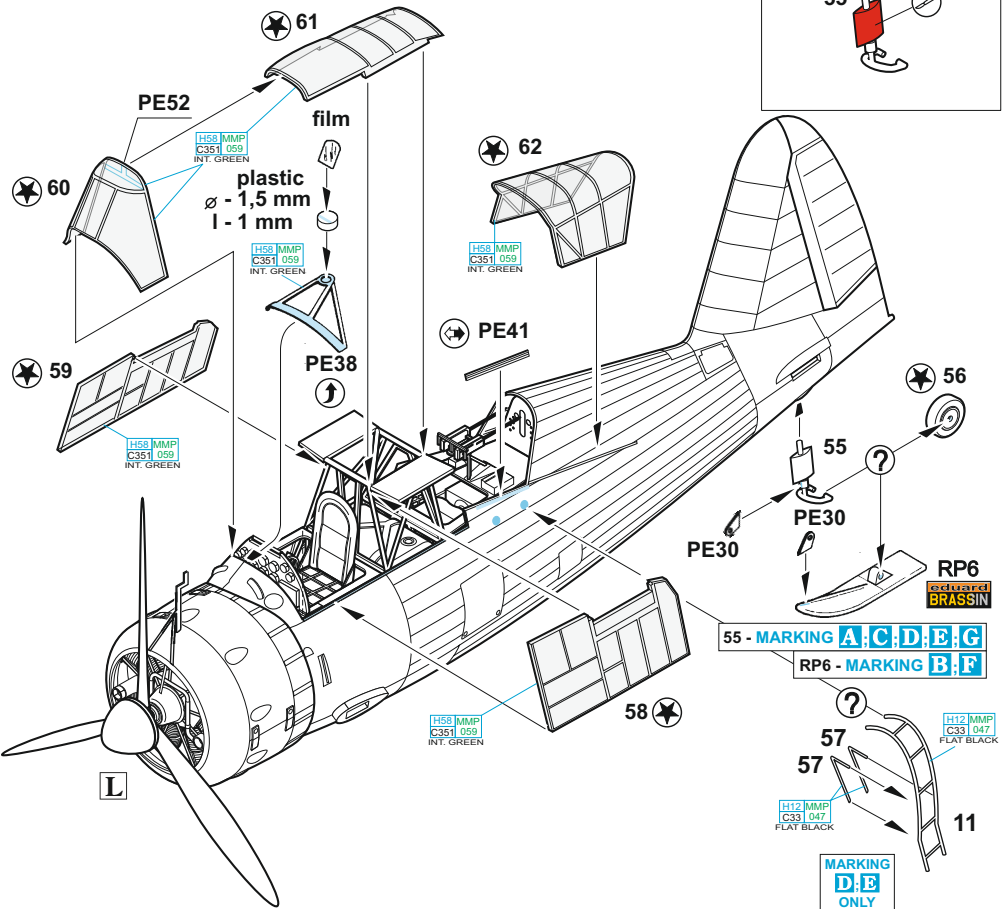
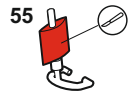
N**O****MARKING C ONLY**

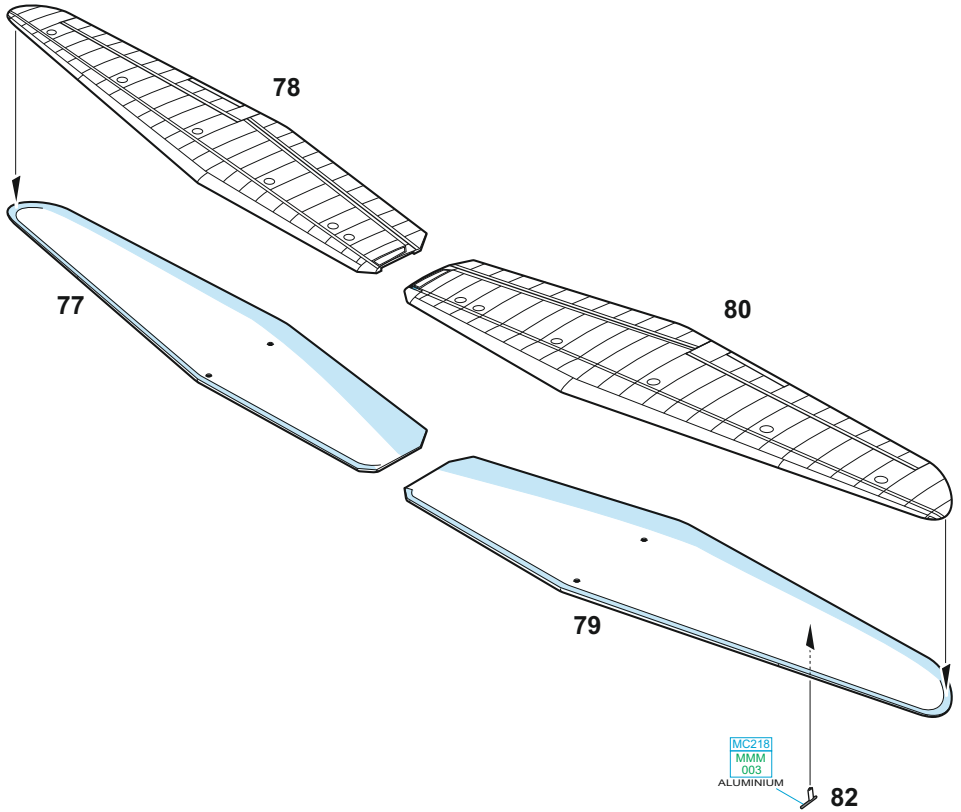

P ? 2 pcs.

MARKINGS **A**; **B**; **D**; **G** ONLY

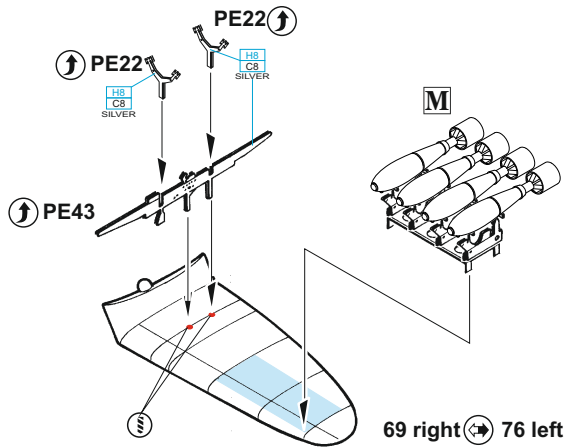

Q

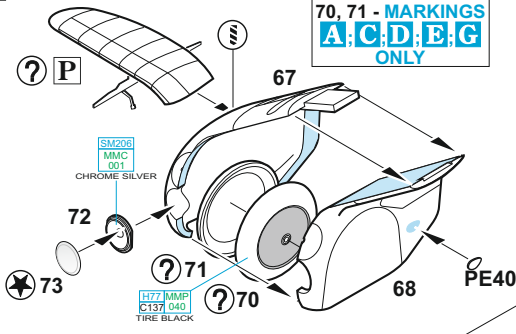

R

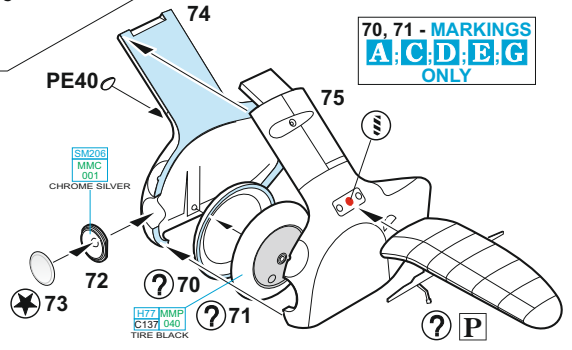

? MARKINGS **B; F** ONLY

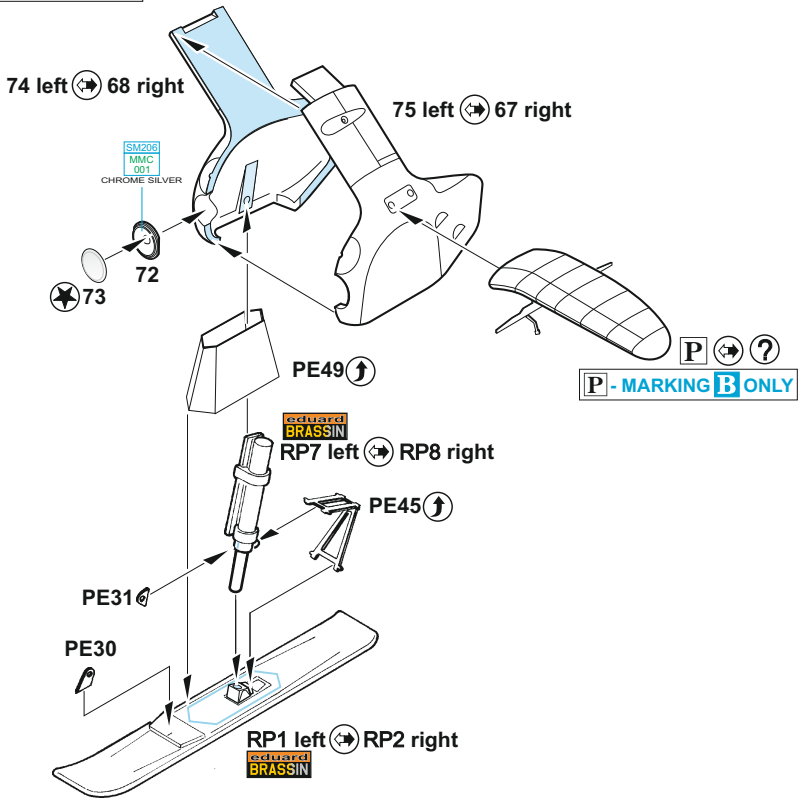

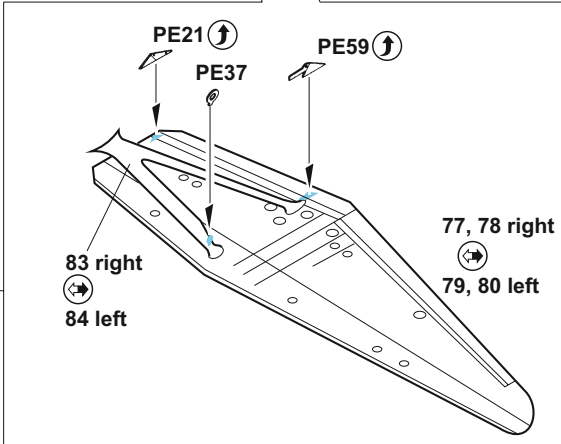
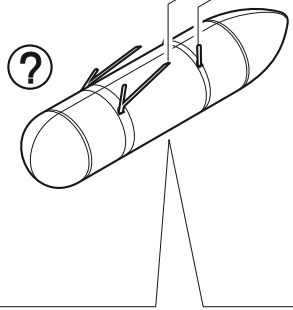
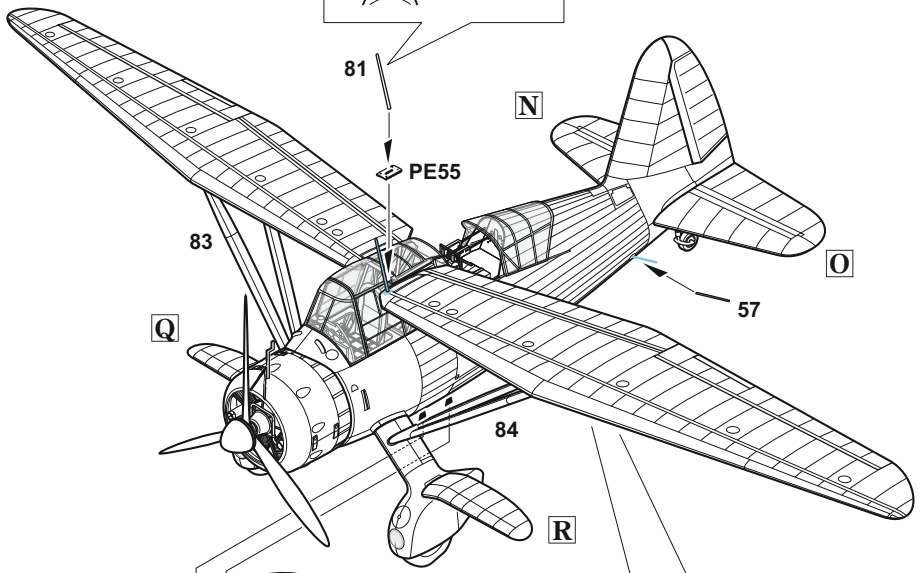
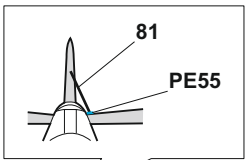

MARKINGS C; E ONLY

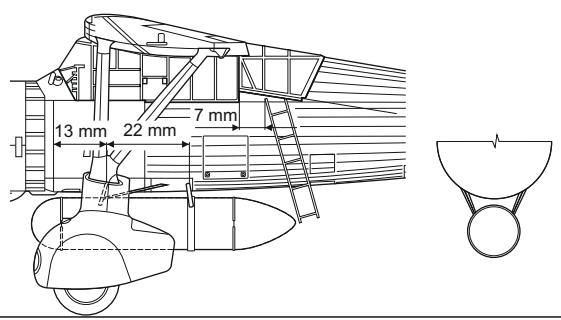
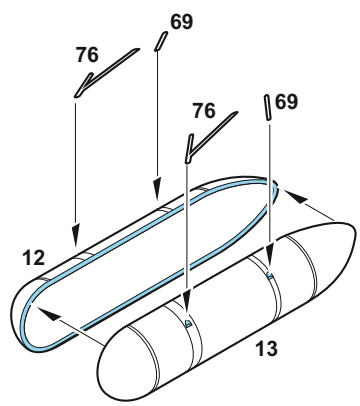

A Lysander Mk.III, T1429, No. 26 Squadron, Gatwick AB, 1940/41

At the beginning of the Second World War, No. 26 Squadron, along with their Lysanders, was transferred to French territory and their task was army co-operation. After the Wehrmacht marched through the Netherlands and Belgium and began to spread through France, the unit was recalled to Great Britain, from where they conducted reconnaissance, bombing and supply missions. After the fall of France, the unit conducted reconnaissance flights over ports from which Britain anticipated a possible German invasion of the home island. In February 1941, the Lysanders were supplemented by Tomahawks that would be tasked with attack missions over northern France. At the beginning of the year, the Tomahawks were replaced by Mustangs, which eventually also replaced the Lysanders.

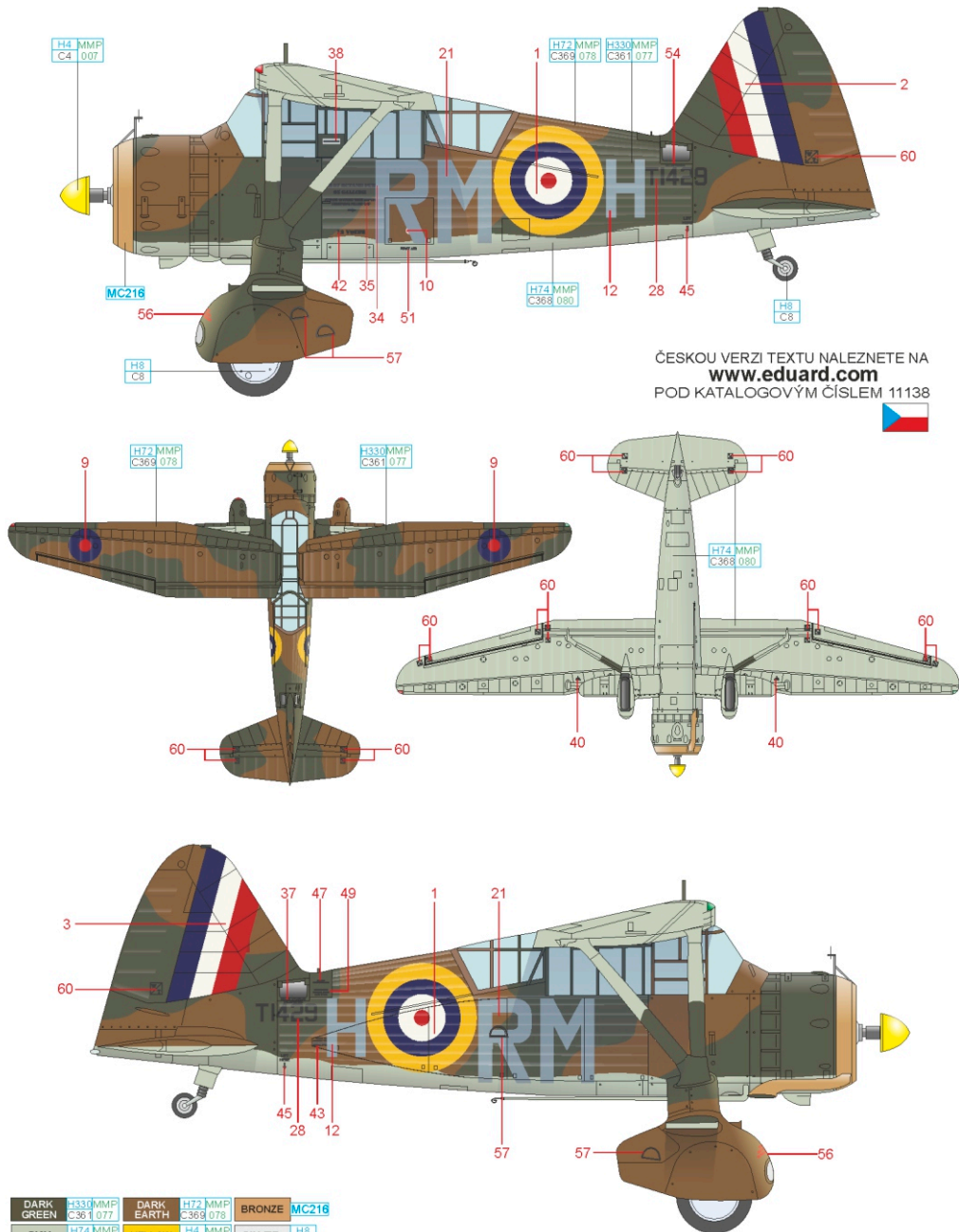

B Lysander Mk.I, LY-116, 2/ Lentolaivue 16, Hirvas airfield, Finland, January 1943

During the winters of 42/43 and 43/44, the Finnish Air Force applied temporary white paint, a mix of lime, glue and water, over their black and green camouflaged assets in an effort to better conceal them from the enemy during these seasons. The lower surfaces that were painted in what was designated DN-väri, a light blue-grey, were not painted over. The same went for Eastern Front aircraft identification markings. To improve mobility along the ground, the wheels were replaced with skis.

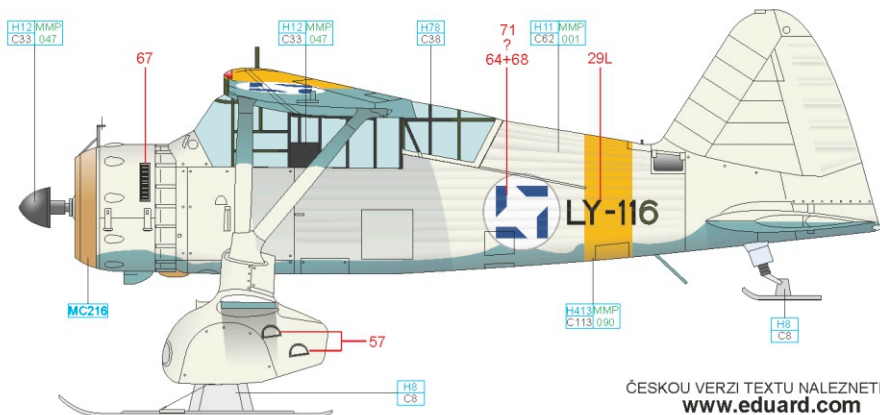

ČESKOU VERZI TEXTU NALEZNETE NA
www.eduard.com
POD KATALOGOVÝM ČÍSLEM 11138

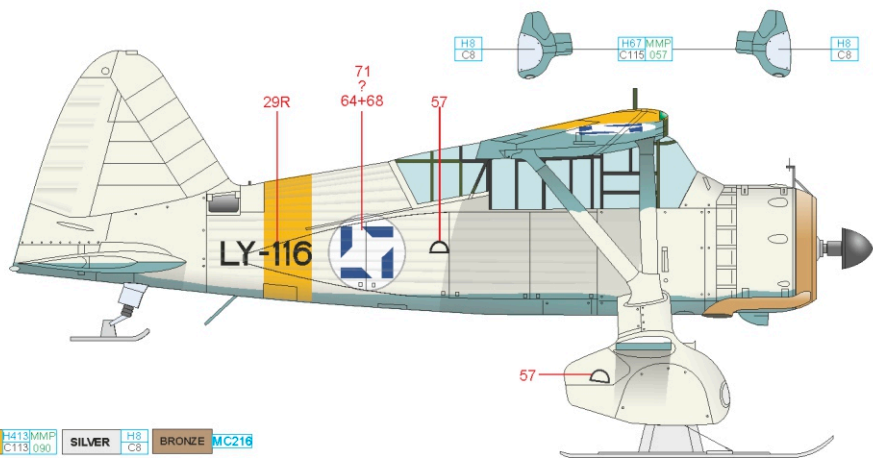
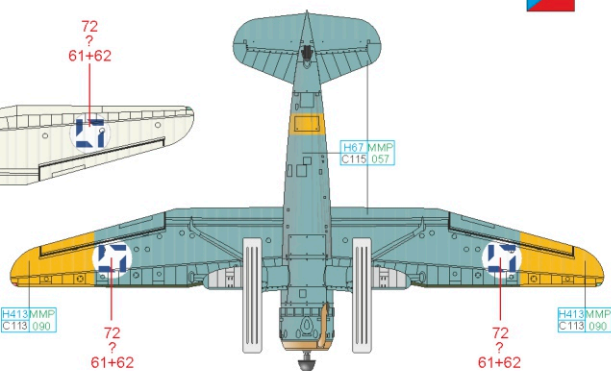
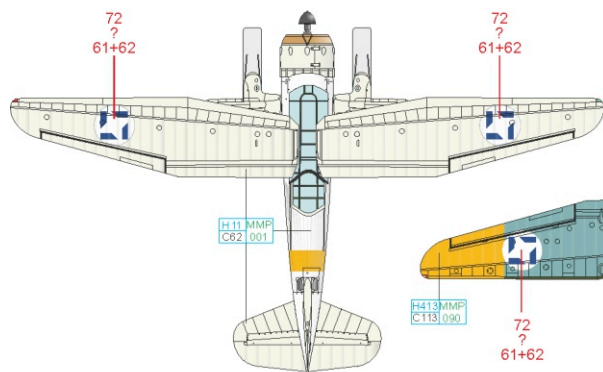

RLM 04	H413 MMP C113 090	SILVER	H8 C8	BRONZE	MC216
RLM 05	H67 MMP C115 057	OLIVE GREEN	H78 C38	WHITE	H11 MMP C62 001
					BLACK
					H12 MMP C33 047

C Lysander Mk.IIIA, V9289, No. 357 Squadron, Burma, June 1945

No.357 Squadron was formed in February 1944 in the western Indian town of Digri. The equipment was made up of Hudsons, Liberators, Dakotas and Catalinas. Agents and guerilla units were dispatched using these aircraft in areas of current Burma, Malaysia and Indonesia. These areas were under Japanese control, and material support was also given to the local resistance to the occupiers. In 1945, Lysanders were also added to the list of aircraft used, and these were able to pick up agents in the dense jungles and return them back to India.

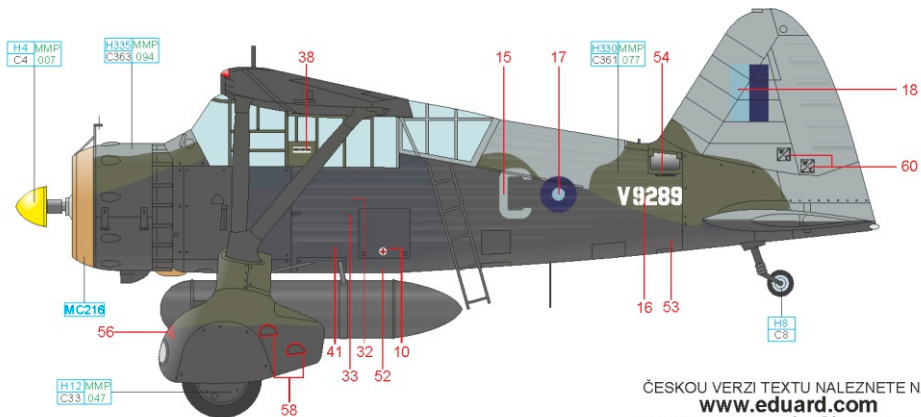

ČESKOU VERZI TEXTU NALEZNETE NA
www.eduard.com
 POD KATALOGOVÝM ČÍSLEM 11138

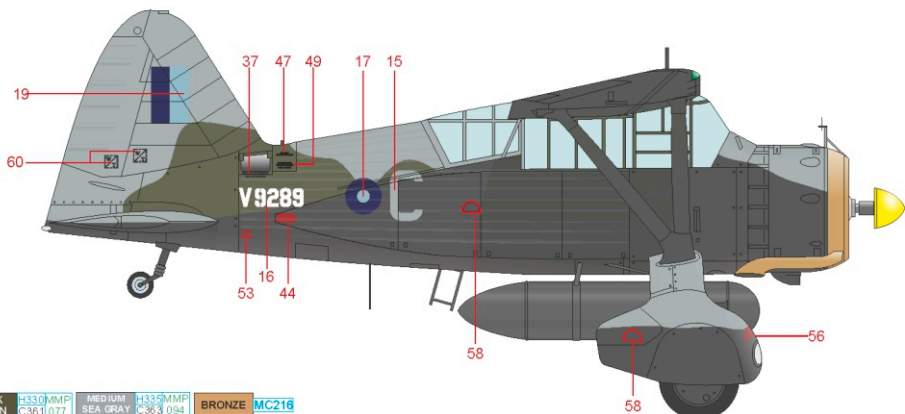
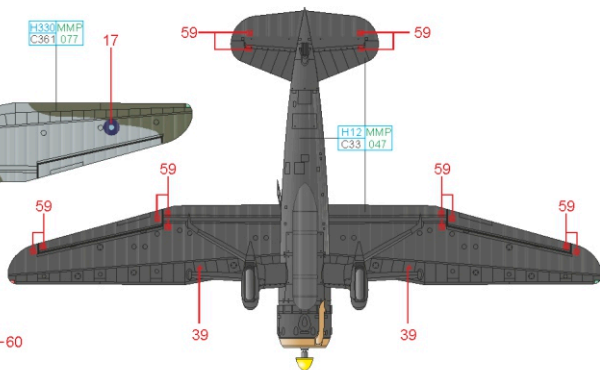
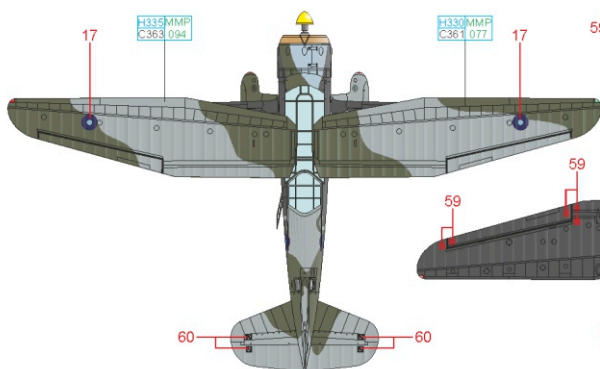

DARK GREEN	H330 MMP C361 077	MEDIUM SEA GRAY	H335 MMP C363 094	BRONZE	MC216
BLACK	H12 MMP C33 047	YELLOW	H4 MMP C4 007	SILVER	H8 C8

D Lysander Mk.IIIA, V9437, No. 309 Squadron, Dunino Airfield, United Kingdom, 1942

Besides Polish manned fighter and bomber units, formed on the basis of an agreement between the British and Polish in Exile governments, No. 309 Squadron was activated in October 1940, tasked with army co-operation with Polish ground units operating out of United Kingdom. The unit was equipped with the Westland Lysander, using the type until 1943. In July, several Mustangs were delivered, ensuring the ability to conduct tactical reconnaissance flights over French territory, while the Lysanders continued in their co-operation duties. In March 1943, the unit was completely rearm with the Mustang and the Lysanders were so replaced.

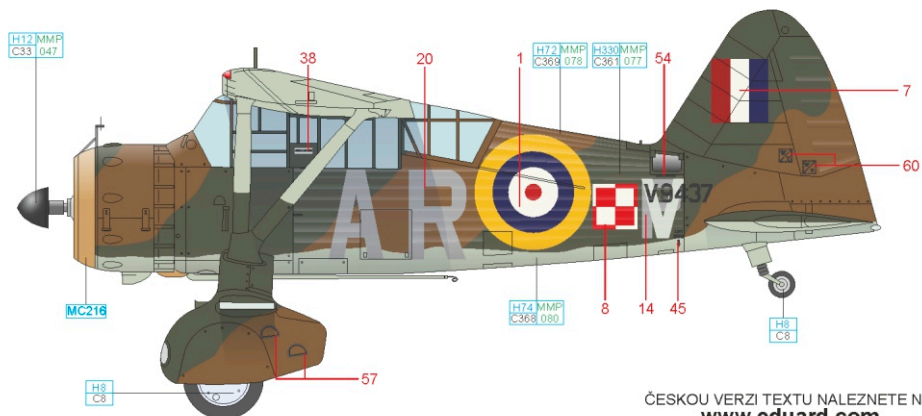

ČESKOU VERZI TEXTU NALEZNETE NA www.eduard.com

POD KATALOGOVÝM ČÍSLEM 11138

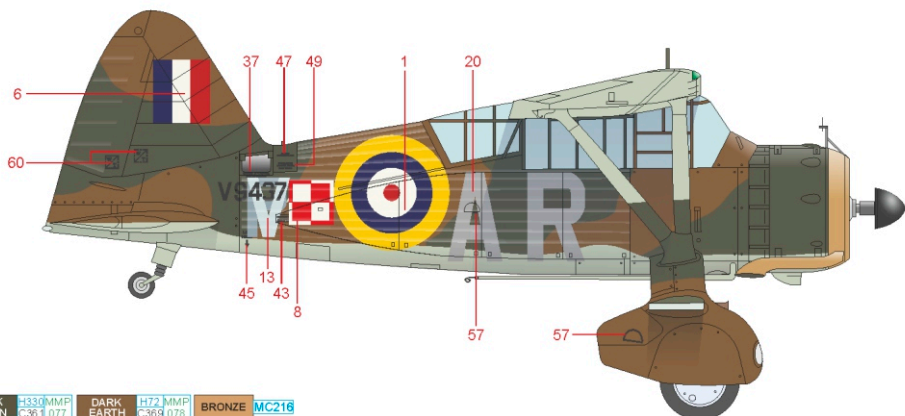
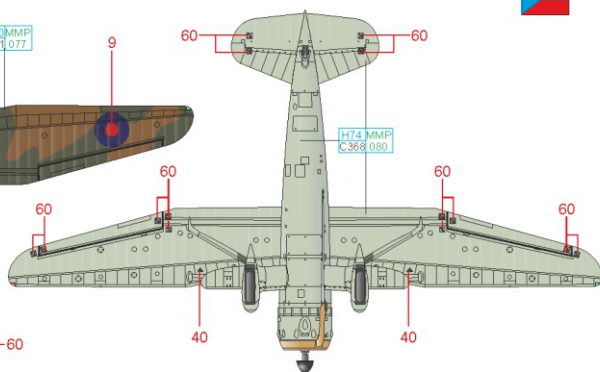
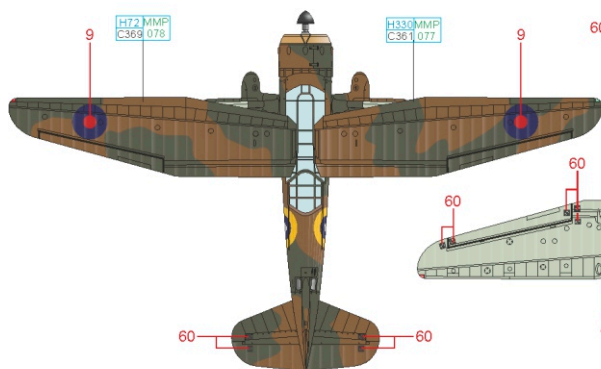

DARK GREEN	H330 MMP C361 077	DARK EARTH	H72 MMP C369 078	BRONZE	MC216
SKY	H74 MMP C368 080	BLACK	H12 MMP C33 047	SILVER	H8 C8

F Lysander Mk.I, LY-119, 2/ Lentolaivue 16, Viiksjärvi landing ground, Finland, February 1942

The Finnish Air Force took delivery of a dozen Lysanders in the spring of 1940. Nine of them were transported by ship to Sweden, where they were assembled and flown to Finland. The remaining three airframes were flown over directly from England due to the increasingly urgent preparations, and aircraft LY-124 was unfortunately lost over Stavanger, Norway, during the ferry flight. All aircraft (LY-114 to LY-125) were painted at the plant in the same way as those delivered to the RAF, in Dark Green and Dark Earth over the upper and side surfaces, while the lower areas were aluminium doped. On this Finnish aircraft, the upper surfaces were changed in June 1941. The squadron insignia was a silhouette of Diana, and was applied to the fin. Same as with aircraft coded LY-116, the wheels were replaced with skis for better take off and landing performance from snowy air strips.

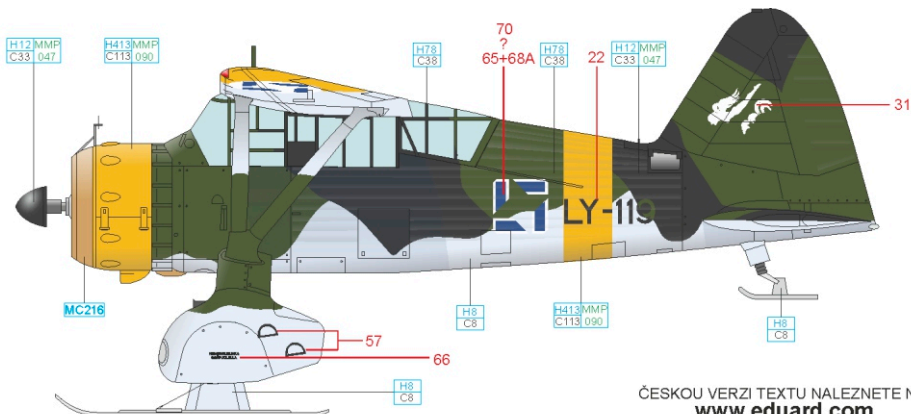

ČESKOU VERZI TEXTU NALEZNETE NA www.eduard.com POD KATALOGOVÝM ČÍSLEM 11138

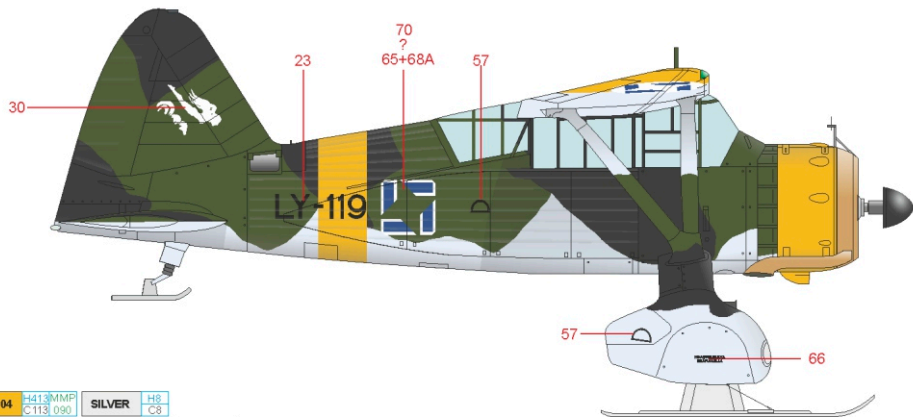
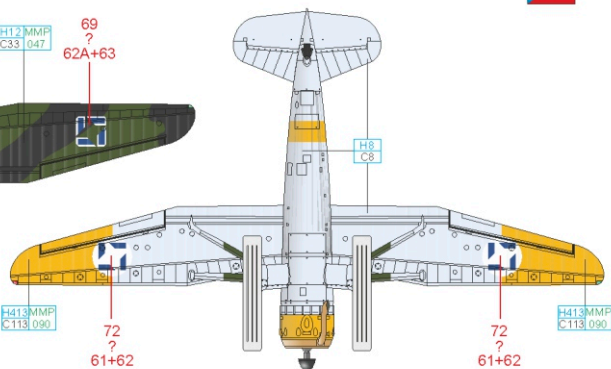
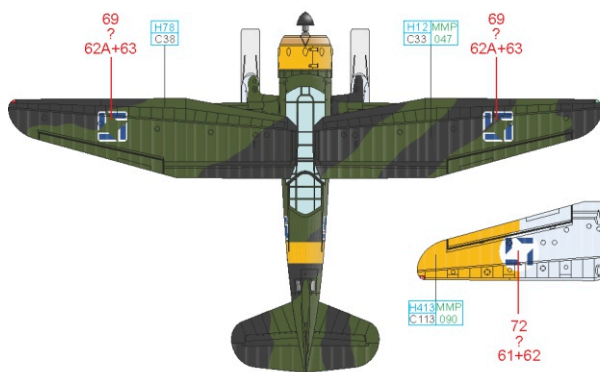

RLM 04	H413 MMP C113 090	SILVER	H8 C8
BLACK	H12 MMP C33 047	OLIVE GREEN	H73 C38
		BRONZE	MC216

G Lysander Mk.I, LY-119, 2/Lentolaivue 16, Hirvas Airfield, Finland, September 1943

The camouflage scheme on the upper and side surfaces of LY-119 was to the Finnish standard, put in place on September 30th, 1940, and in April 1943, also received a light blue-grey application of DN-väri on the lower surfaces. At the same time, the national insignia was modified on the upper and side surfaces of the aircraft.

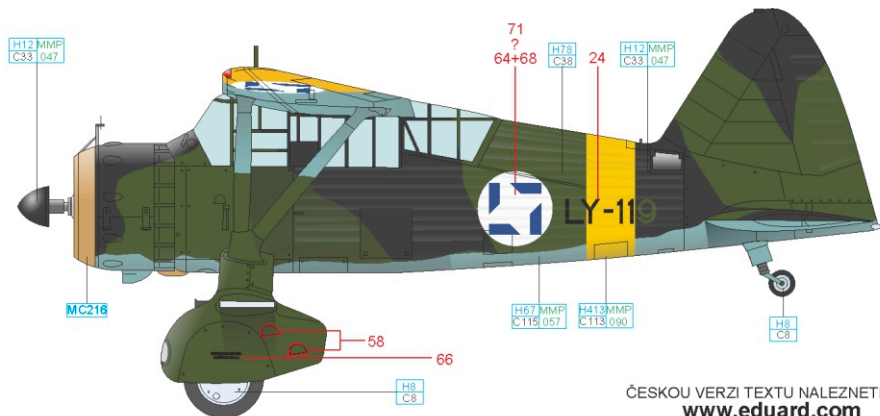

ČESKOU VERZI TEXTU NALEZNETE NA
www.eduard.com
POD KATALOGOVÝM ČÍSLEM 11138

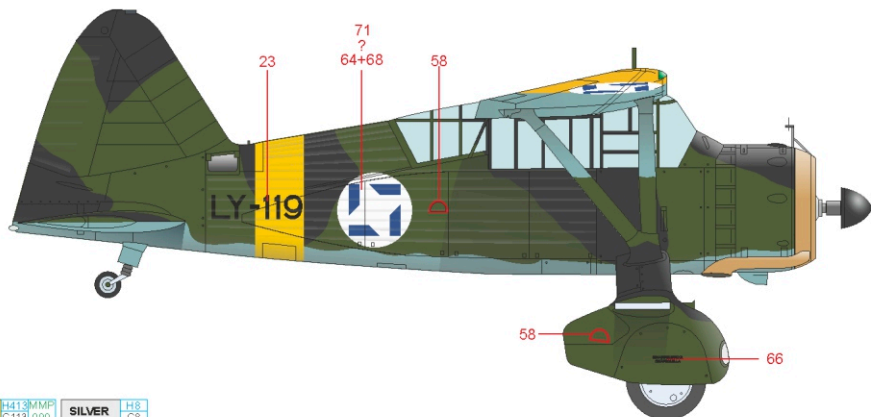
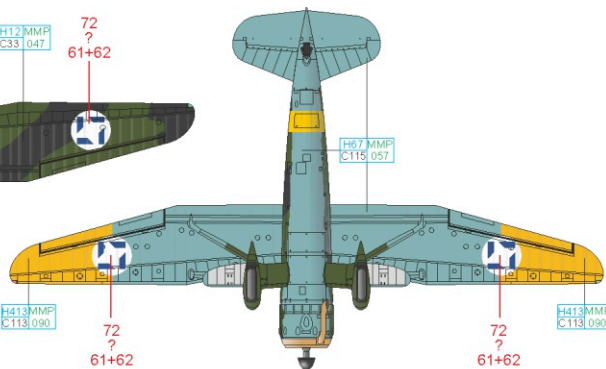
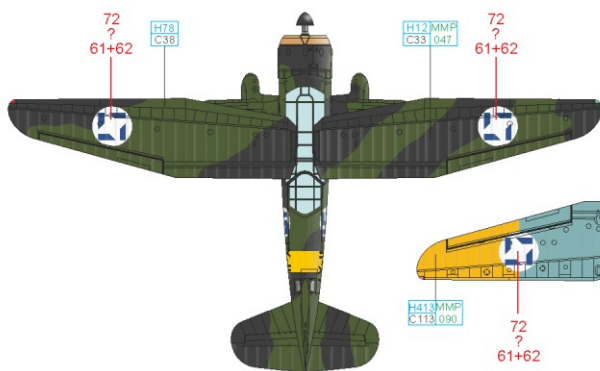

RLM 04 H413 MMP C113 090 SILVER H8 C8

BLACK H12 MMP C33 047 RLM 65 H67 MMP C115 057 OLIVE GREEN H78 C38 BRONZE MC216

eduard