

AeroMaster

48-036 Lightnings in the Sky

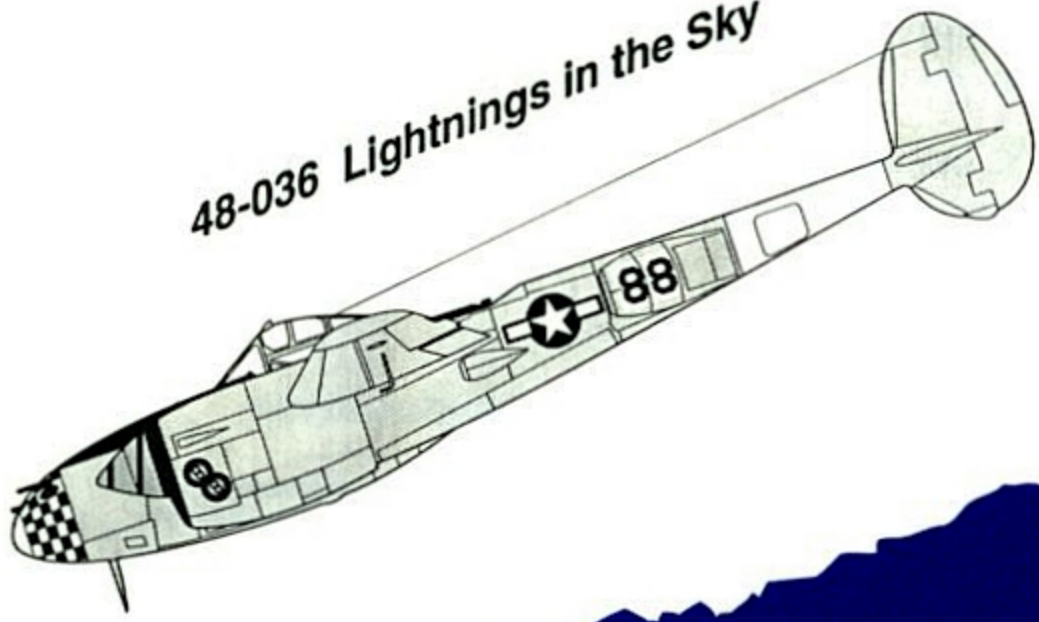

AeroMaster Decals

TM

3615 NW 20th Avenue
Miami, Florida 33142 USA
(305) 633-8118 • Fax (305) 634-3630

3615 NW 20th Ave • Miami, Florida 33142 • USA

Tel. (305) 635-3134 • Fax (305) 635-2106

P-38J-25, 44-23675, "Les Vin, Les Femmes, et Les Chanson", 485th FS, Florennes, Fall 1944. Flown by Maj. Sabo. Overall natural metal with black & white invasion stripes on bottom of wings & lower half of tail booms. Black anti-glare panels on nose & inboard side of engine nacelles. Spinners red with dark blue tips. Front of cowlings red. (note: this A/C had "greyed out" national insignia.)

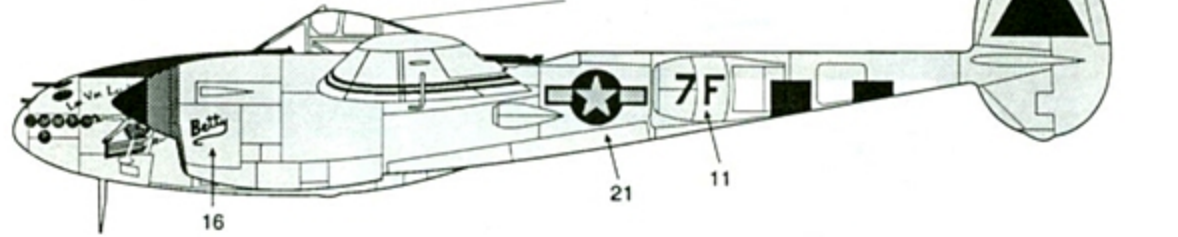
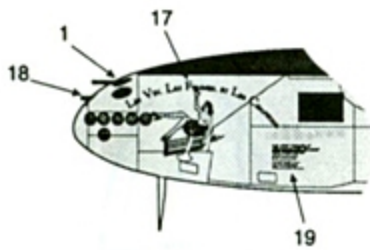

P-38J-20-LO, 42-3511, "Arkansas Traveler", 392nd FS, 367th FG, 1945. Flown by Lt. Owen Fincher. Overall natural metal. O.D. anti-glare panels on nose & inboard side of engine nacelles. Tip of nose & spinners red.

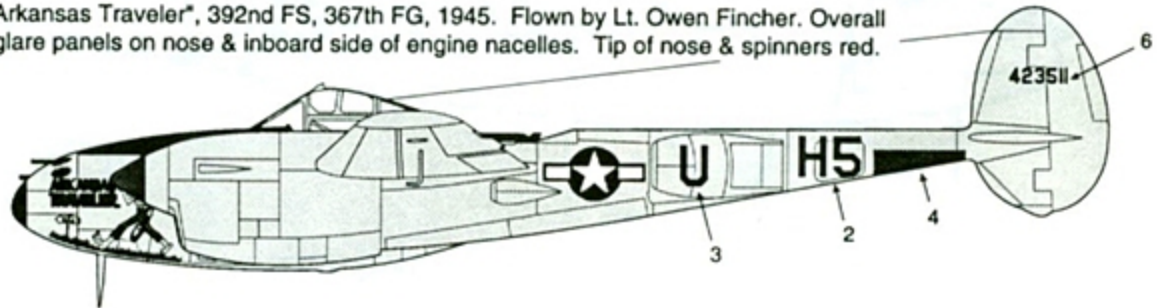

P-38J, "Jandina IV", 80th FS, 8th FG, S.W. Pacific, 1944. Flown by Maj. J. T. Robbins. Overall natural metal. O.D. anti-glare panels on nose & inboard side of engine nacelles. Rear of spinners green with white bands. Tip of nose white. Upper & lower tips of tails green with thin white stripes (paint to match [35]).

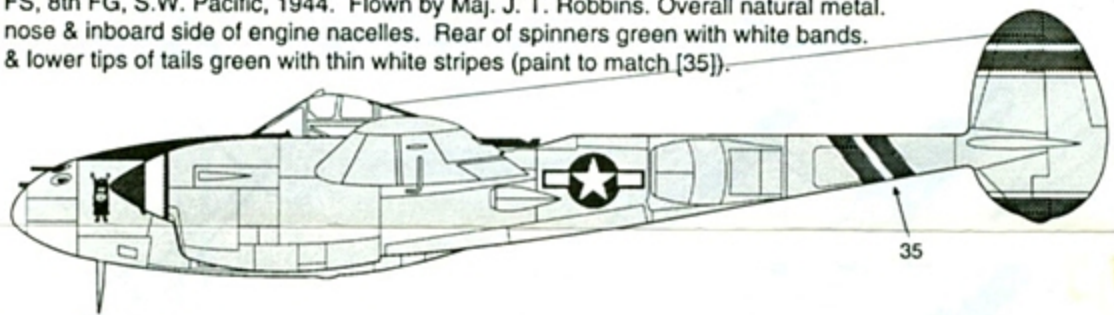
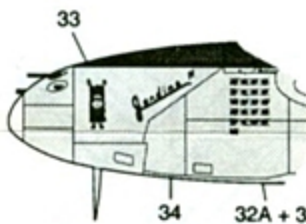

P-38J, "Uncle Cy's Angel", 80th FS, 8th FG, S.W. Pacific, 1944. Flown by Capt. C. F. Homer. Overall natural metal. O. D. anti-glare panels on nose inboard side of engine nacelles. Spinners green with white tips & back plates. Upper & lower tips of tails green with thin white stripes (paint to match [35]).

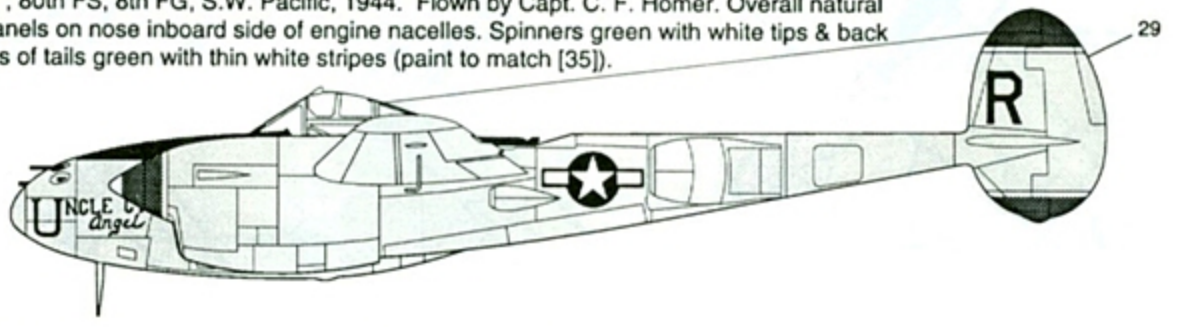
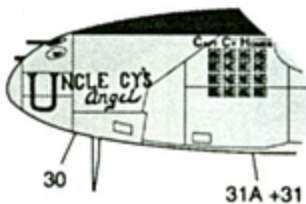

P-38L, "Pappy's Birr-die", 431st FS, 1945. Flown by Maj. R.I. "Pappy" Cline. Overall natural metal. Black anti-glare panels on nose & inboard side of engine nacelles with red trim on nose panel. Rear of spinners red. Upper & lower tips of tails red with thin black stripe (paint to match [28]).

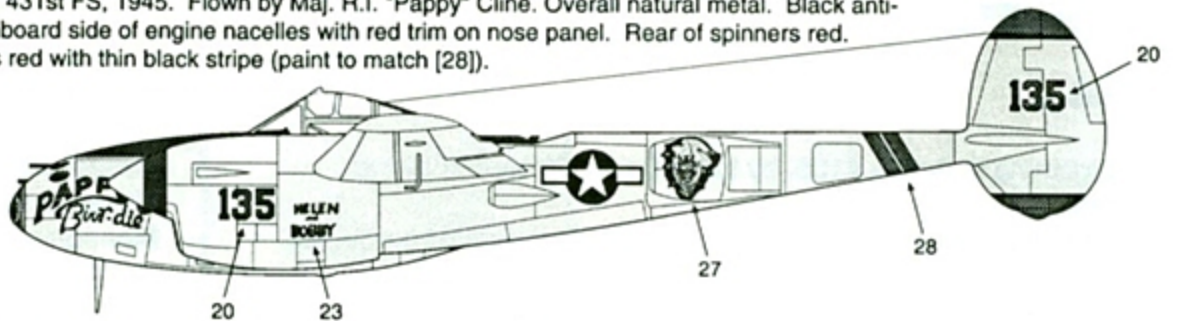
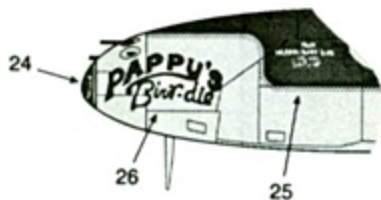

P-38J, 94th FS, 1st FG, Italy. Overall natural metal. Black anti-glare panels on nose & inboard side of engine nacelles. Spinners yellow with red spiral bands. Front of cowlings black. (note: paint front of nose white before applying black checker decals)



Note: additional U.S. national insignias can be obtained from AeroMaster sheet 48-054.

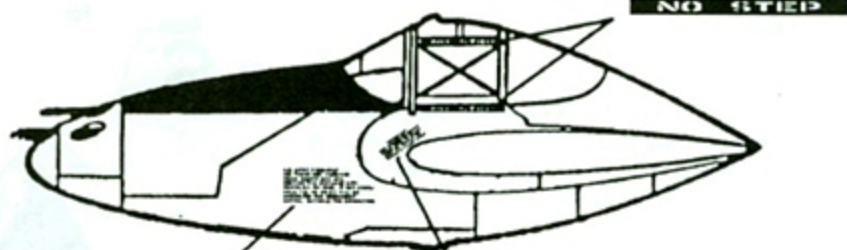

U.S. ARMY P-38L-5-LO
AIR FORCE SER. 4328-438
CREW WEIGHT 200 LBS.
SERVICE THIS AIRPLANE WITH
GRADE 100 130 FUEL. IF NOT AVAIL-
ABLE, T.O. NO. CG-5-1 WILL BE
CONSULTED FOR EMERGENCY
ACTION. SUITABLE FOR AROMATICS.

IMPORTANT
FOR MANEUVERABILITY
FRONT EDGE OF FILLET
MUST BE TIGHTLY ON
MICARTA FILLER STRIP

FURTHEST FORWARD LOAD 148 lb
GROSS WT WHEELS DOWN 151 88
GROSS WT WHEELS UP 154 71
FURTHEST AFT LOAD 156 lb



CAUTION
AFTER CASTING IS SNUG
WITH WIND, TIGHTEN NUT

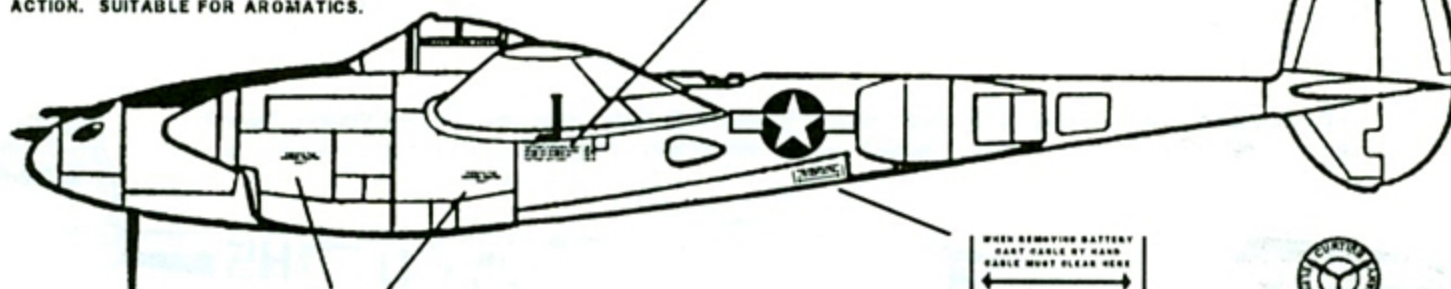

REMOVE FOR
GROUND HEATER
DUCT

WHEN REMOVING BATTERY
PART HANDLE BY HAND
PARTS MUST CLEAR HERE



Curtiss Electric Logo
Apply to front side of prop blades.

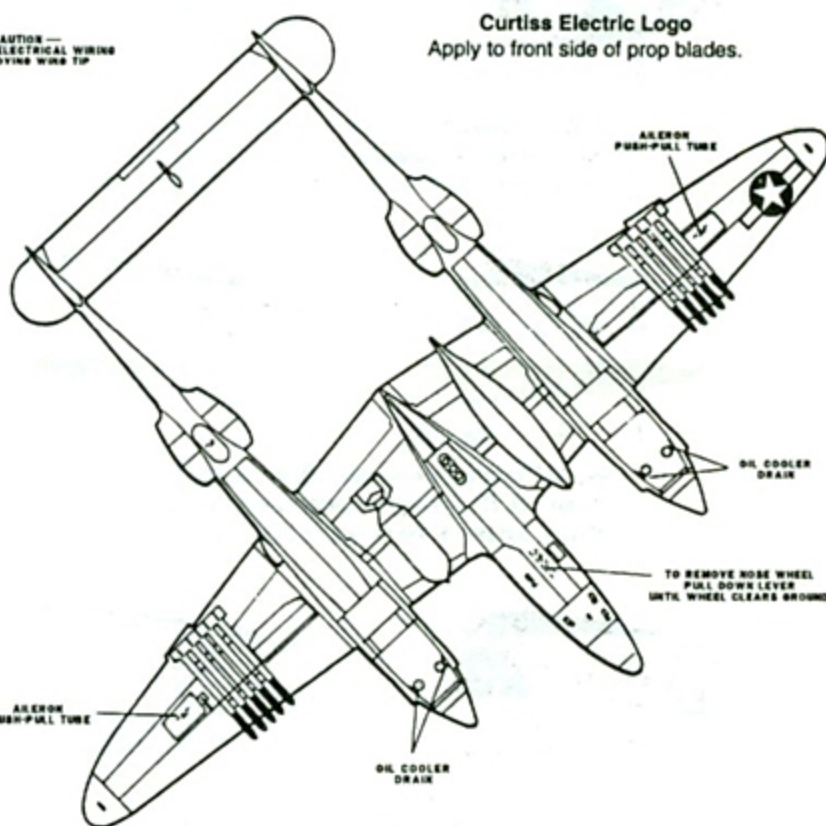
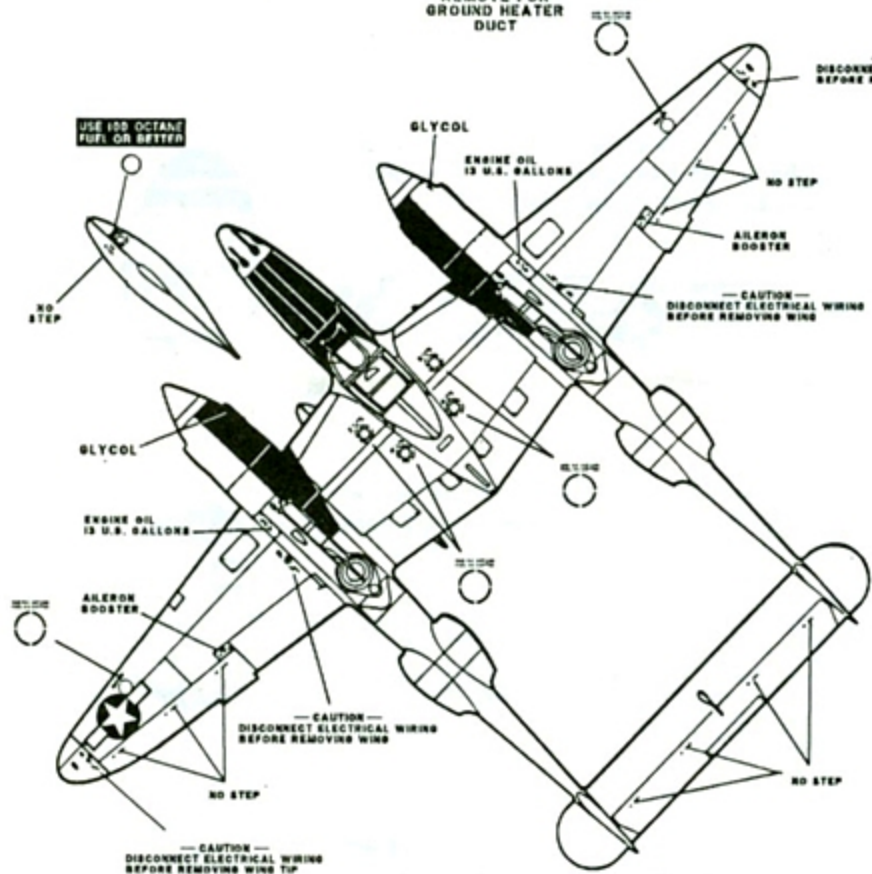

References:

1. P-38 Lightning in Action #109, by Larry Davis, Squadron Signal Publications, 1990.
2. P-38 Lightning in Action #25, by Gene B. Stafford, Squadron Signal Publications, 1976.
3. IPMS-USA Quarterly, Vol. 7, No. 3, Fall 1972.
4. Lockheed P-38 Lightning, Aircam Aviation Series No. 10, by Richard Ward and Ernest McDowell.

Suggested Kits:

- Hasegawa P-38J
- Hasegawa P-38L
- Monogram P-38J
- Medallion Models P-38 detail set

If you have suggestions for future subject matter, AeroMaster would like to hear from you. Our goal is to provide high quality, well researched decals of unusual and interesting subjects. We value our customers' inputs, so if you have specific suggestions or photographs of unusual subject matter, please contact: