

1/350 SCALE

ITEM NO.:05340

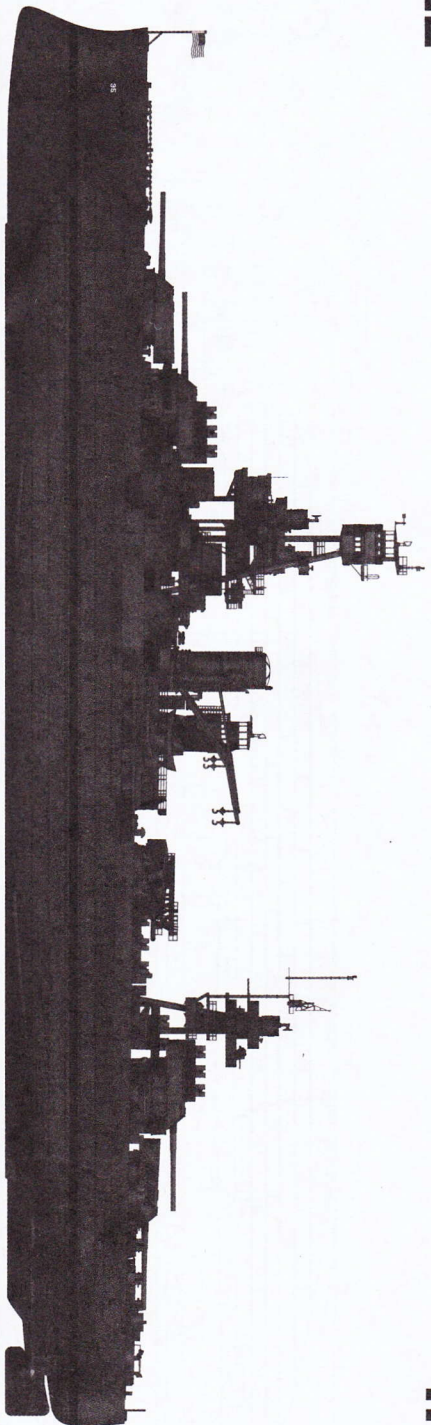

USS TEXAS BB-35

美国海军德克萨斯号战列舰BB-35

READ BEFORE ASSEMBLY:

- This kit is not recommended for inexperienced modelers or for children under 14 years of age
- Study and understand these instructions thoroughly before beginning assembly
- When needed, remove photo-etch parts carefully using a modeling knife or photo etch sprue cutter, being careful not to damage or lose small parts.
- Take extra care in handling photo etch parts in order to avoid injury
- Apply instant cement sparingly to photo etch parts where instructed
- Tools recommended(not included in kit):Plastic and instant cements,sprue cutters,long nose pliers,modeling knife, small files, tweezers, pin vise & scissors. Soft cloth and sandpaper will also assist in construction
- Glue and paint are not included in the kit. Use plastic cement and hobby paints only. Color guide for purchasing paint is included in the kit.
- Keep out of reach of children. They must not be allowed to ingest small parts or handle plastic bags in any way.

装配之前仔细阅读

- 小心用模型锉刀锉平所有零件表面的注射浇口。
- 小心用刀片切下蚀刻片零件，不要遗失小零件。
- 用强力快干胶水粘合蚀刻片零件和金属轴。过量的快干胶水使用可能导致蚀刻零件会粘住，小心涂胶。
- 取蚀刻片时应特别注意安全，防止利刃划伤手指。
- 某些零件表面需贴水上贴纸，请选择在装配的同时进行。
- 推荐模型工具(自备)：胶水，水口剪刀，长钳，刀片，锉刀，镊子钳，钻，剪刀，瞬间快干胶。
- 软布同砂纸同时也应该是必备工具。
- 请使用塑料胶水和油漆，模型内不含。
- 谨防小孩吸吮塑料零件，或者将塑料袋套在头上，制作时应将套材远离小孩接触。
- 本产品不适合14岁以下没有经验的模型爱好者。

水贴纸的使用:

- 1.从水贴上剪下印花;
- 2.将印花放入温水中浸10秒, 然后放在干净布上.
- 3.拿着印花纸将印花移到模型上;
- 4.手指蘸水将印花移到适当的位置;
- 5.用软布轻压印花直至水干, 汽泡消失.

DECAL APPLICATION:

- 1.Cut decals from sheet as needed
2. Dip the decal in warm water for about 10 seconds and then place on soft clean cloth.
3. Hold the decal backing sheet edge and gently slide the decal onto the model in its proper position.
4. While still wet,decal can be adjusted for better fit on model by dampening it gently with your finger.
5. When placed in the proper position,gently press decal down with a soft cloth until excess water and air bubbles are gone.
6. Allow decal to dry completely before handling model



使用强力胶

Cyanoacrylate glue Weight



配重

Make hole



钻孔

Cut / Remove



切除



不涂胶水



弯曲



锉平



选择



File / Sand



Option



No cement



Bend



Decal



File / Sand



Option



No cement



Bend



Decal



File / Sand



Option



No cement



Bend



Decal



File / Sand



Option



No cement



Bend



Decal



File / Sand



Option



No cement



Bend



Decal



File / Sand



Option



No cement



Bend



Decal



File / Sand



Option



No cement



Bend



Decal



File / Sand



Option



No cement



Bend



Decal



File / Sand



Option



No cement



Bend



Decal



File / Sand



Option



No cement



Bend



Decal



File / Sand



Option



No cement



Bend



Decal



File / Sand



Option



No cement



Bend



Decal



File / Sand



Option



No cement



Bend



Decal



File / Sand



Option



No cement



Bend



Decal



File / Sand



Option



No cement



Bend



Decal



File / Sand



Option



No cement



Bend



Decal



File / Sand



Option



No cement



Bend



Decal



File / Sand



Option



No cement



Bend



Decal



File / Sand



Option



No cement



Bend



Decal



File / Sand



Option



No cement



Bend



Decal



File / Sand



Option



No cement



Bend



Decal



File / Sand



Option



No cement



Bend



Decal



File / Sand



Option



No cement



Bend



Decal



File / Sand



Option



No cement



Bend



Decal



File / Sand



Option



No cement



Bend



Decal



File / Sand



Option



No cement



Bend



Decal



File / Sand



部品图
Parts

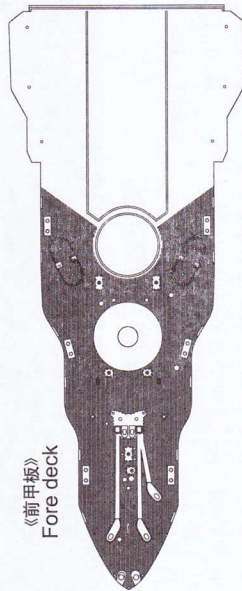
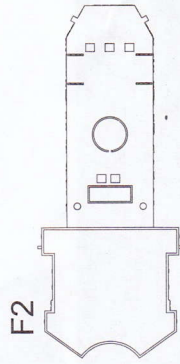
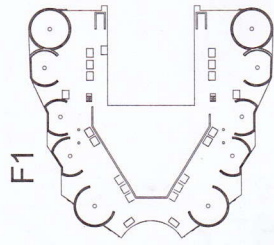
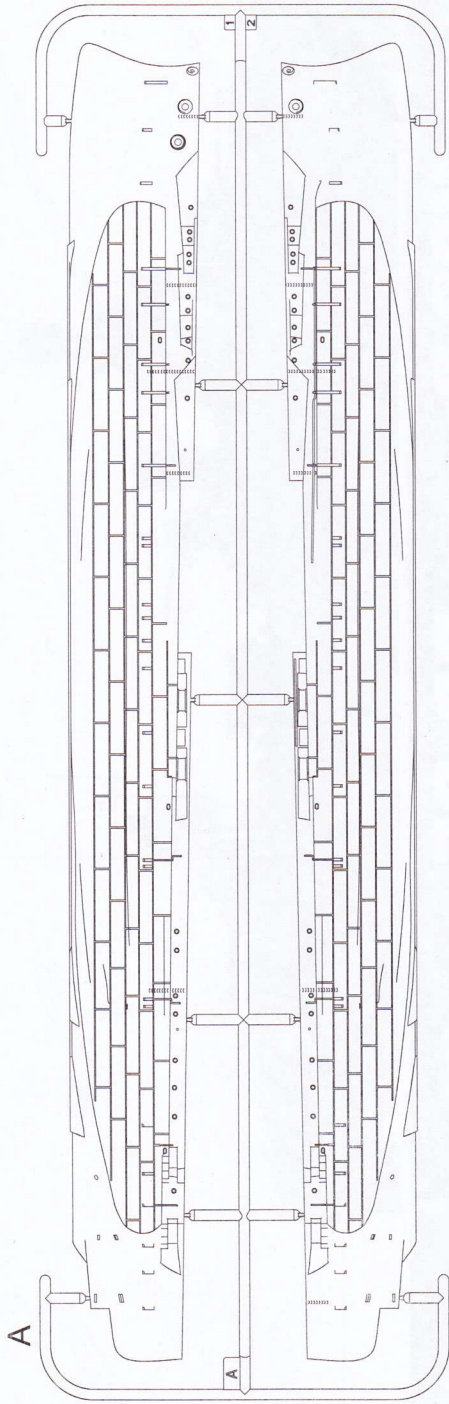

《后甲板》
Rear deck

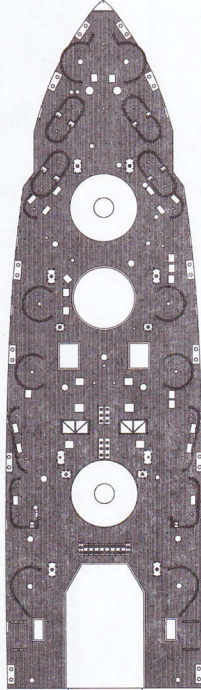

D

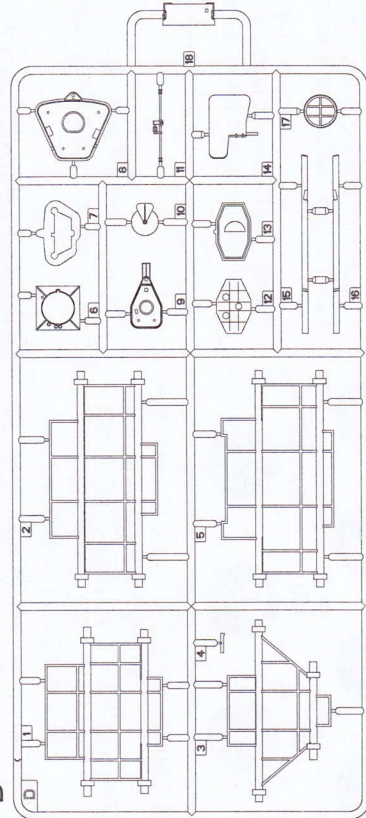

E

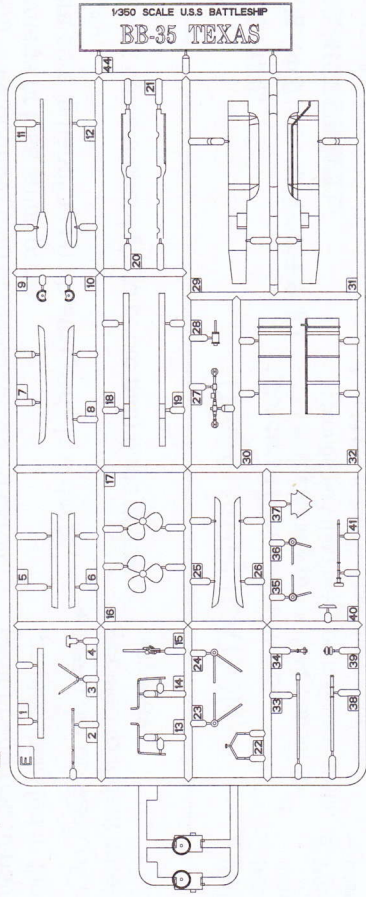

Hx2

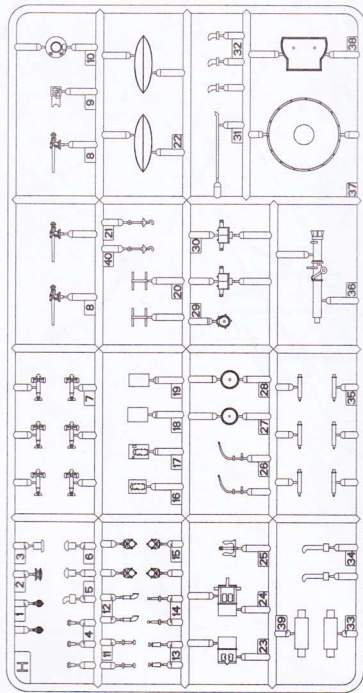

Jx5

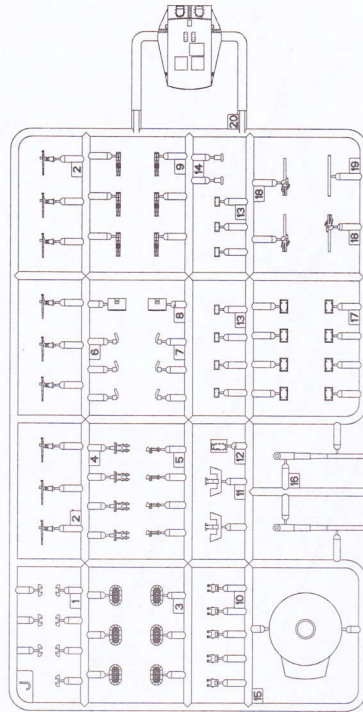

M

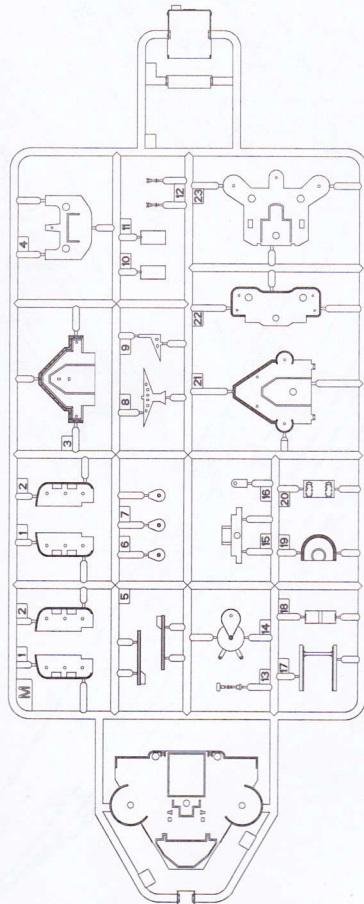

《座架》
Stand

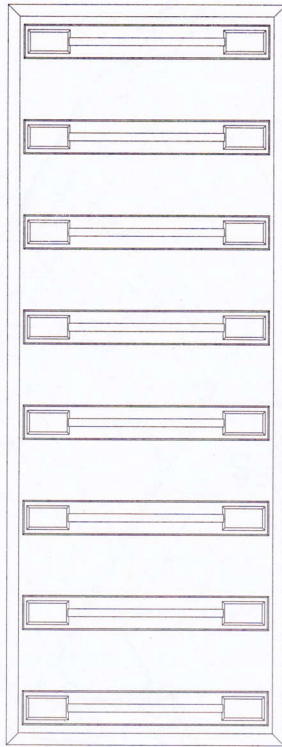

OS2U-1

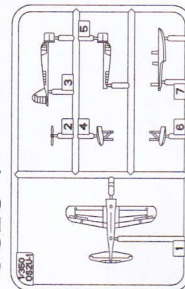

《轴链》
Chain



《蚀刻片》
Photo etched (B)

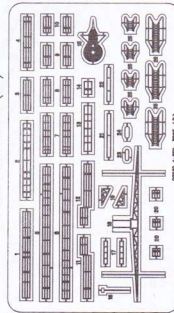

《蚀刻片》
Photo etched (C)

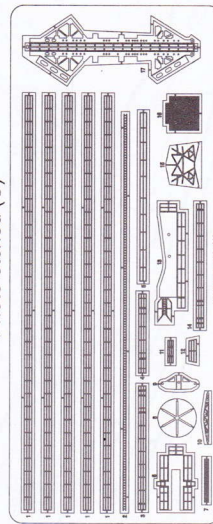

《蚀刻片》
Photo etched (D)x2

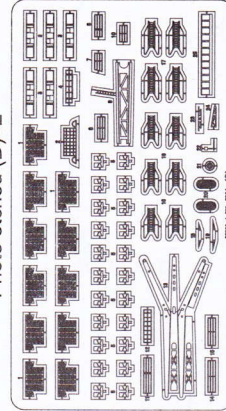

《水贴》
Decal

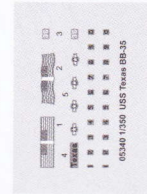

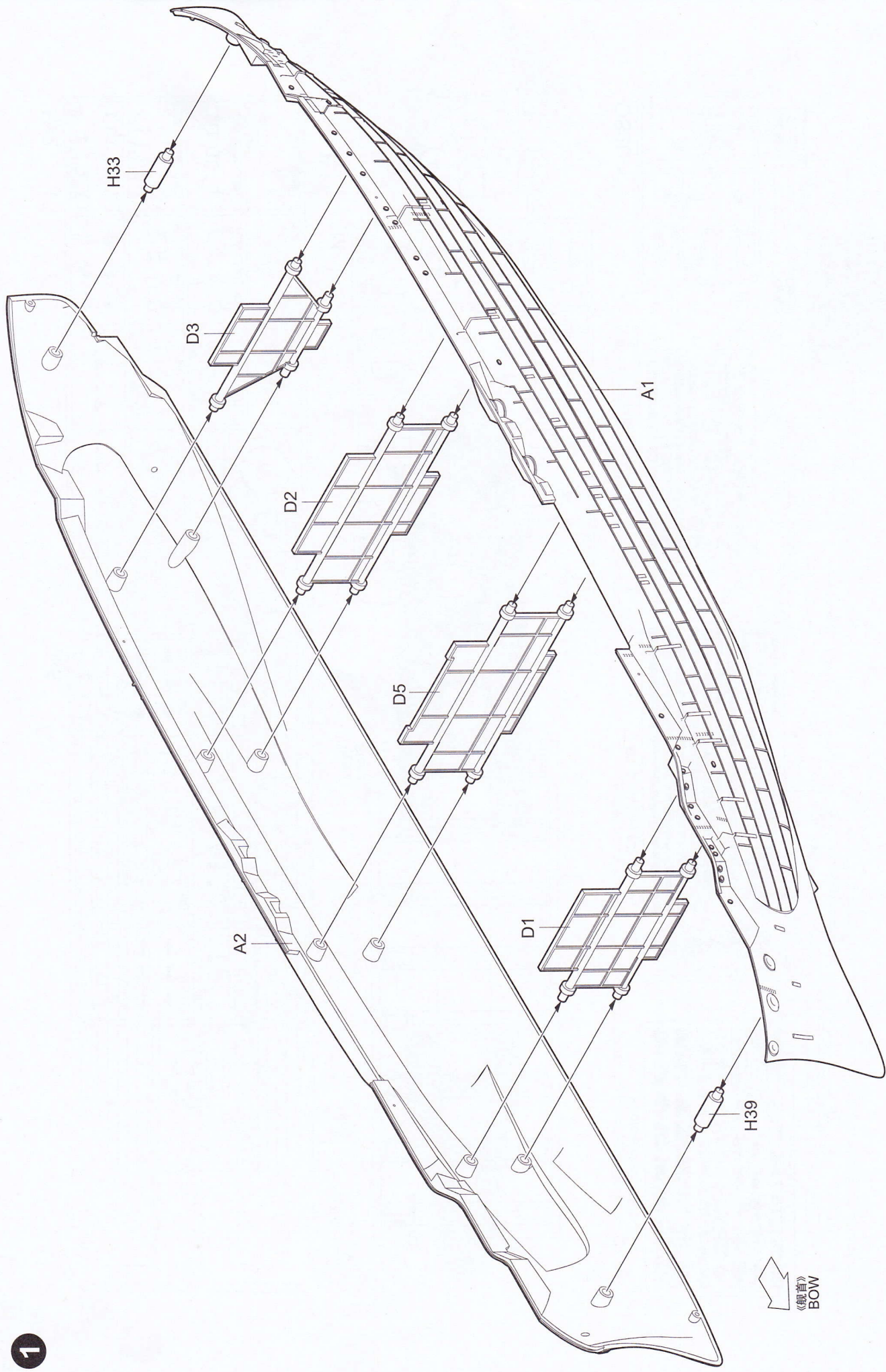

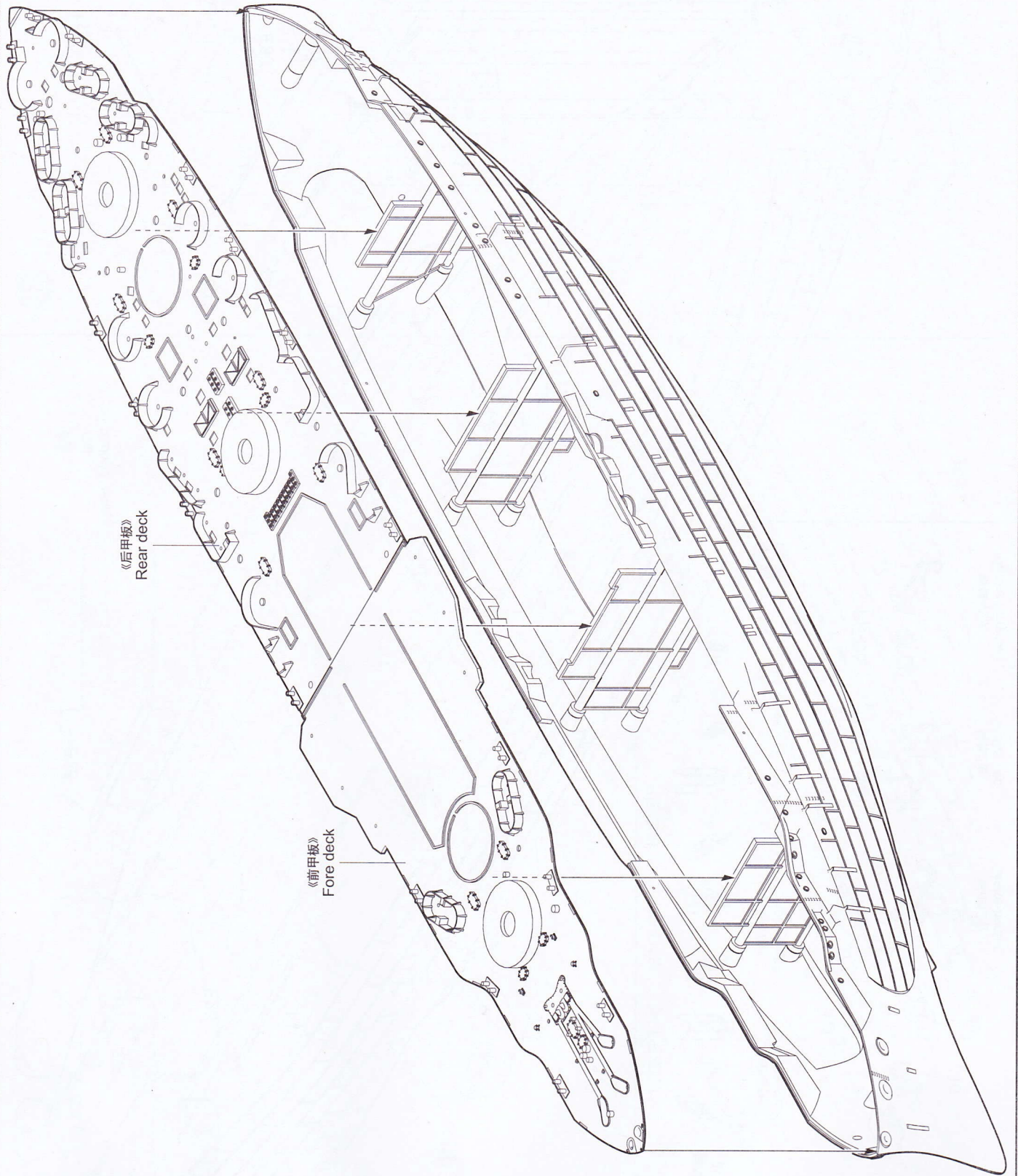

3

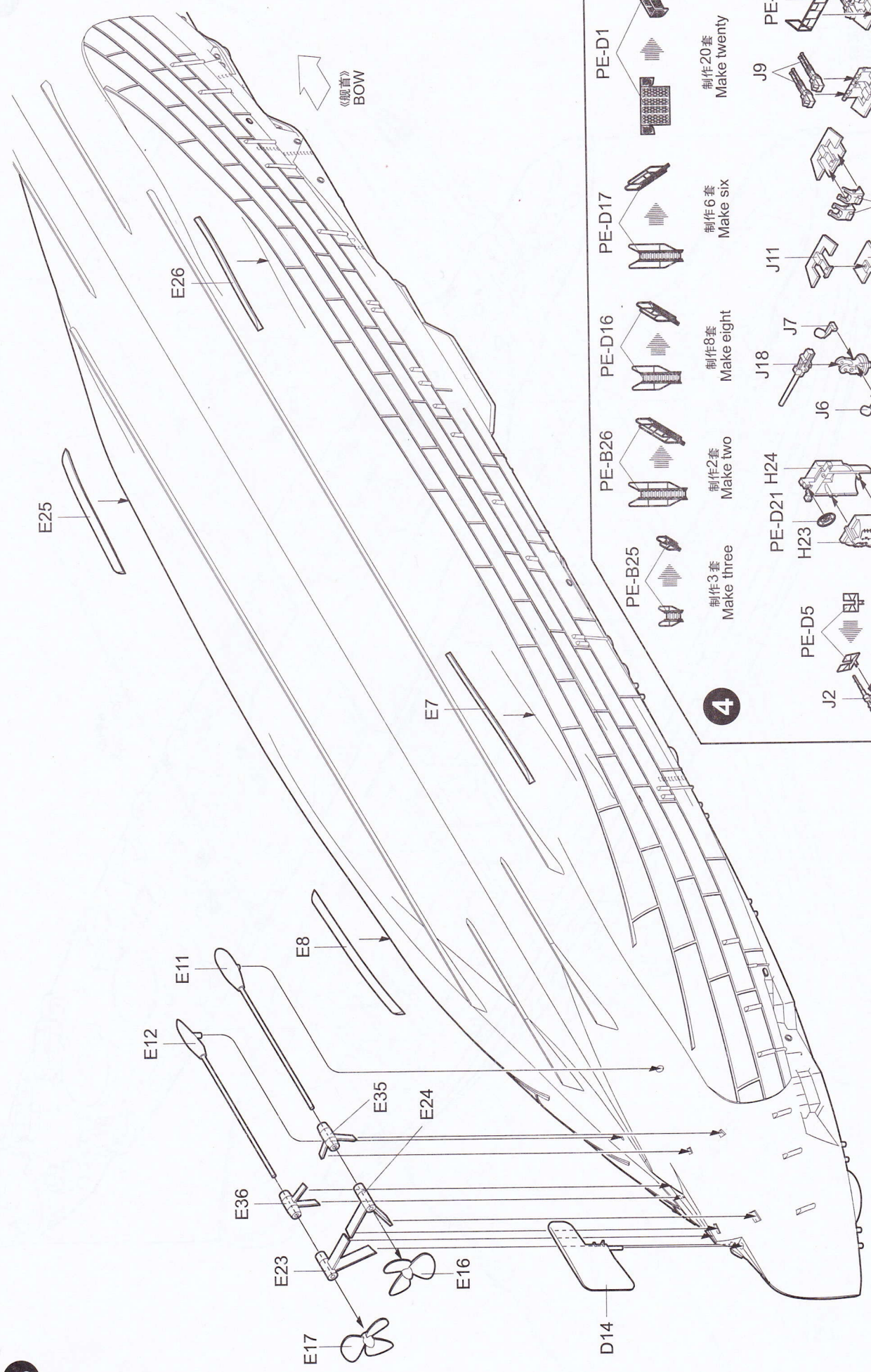

4

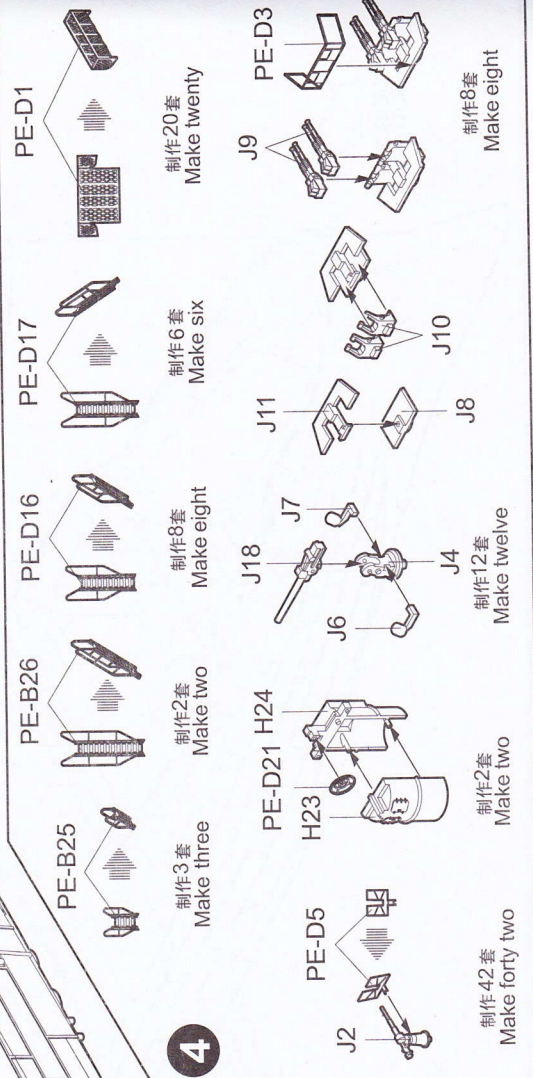

5

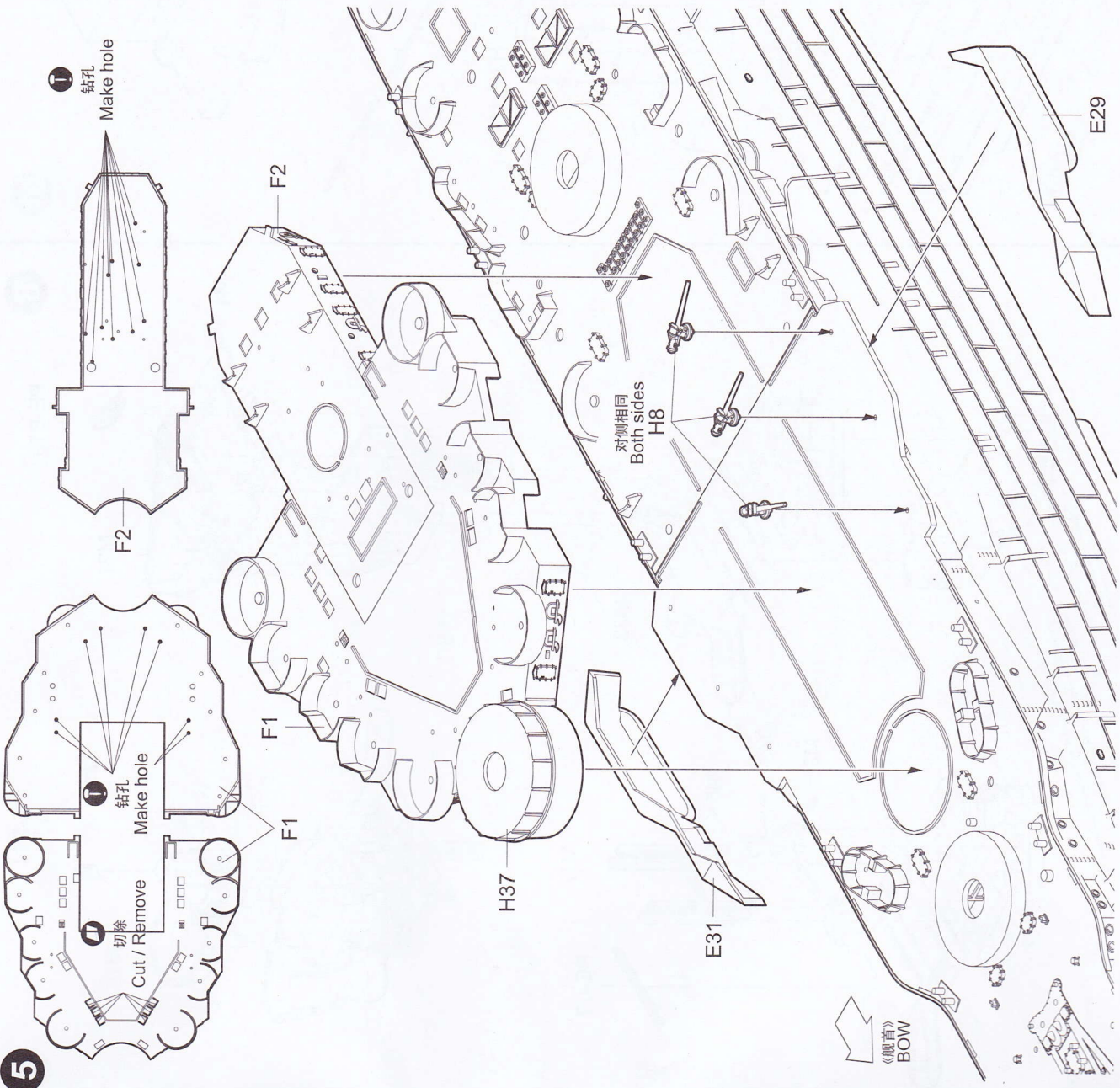

6

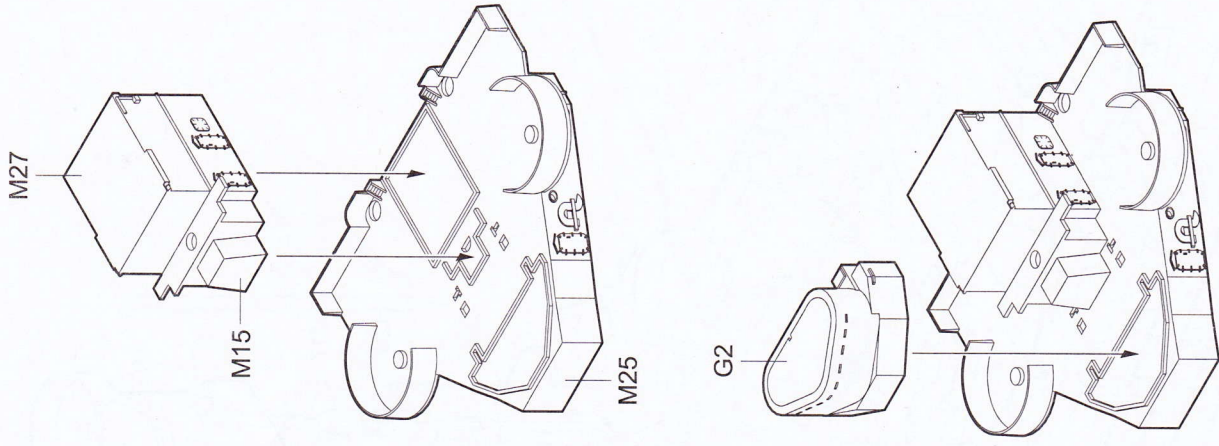

7

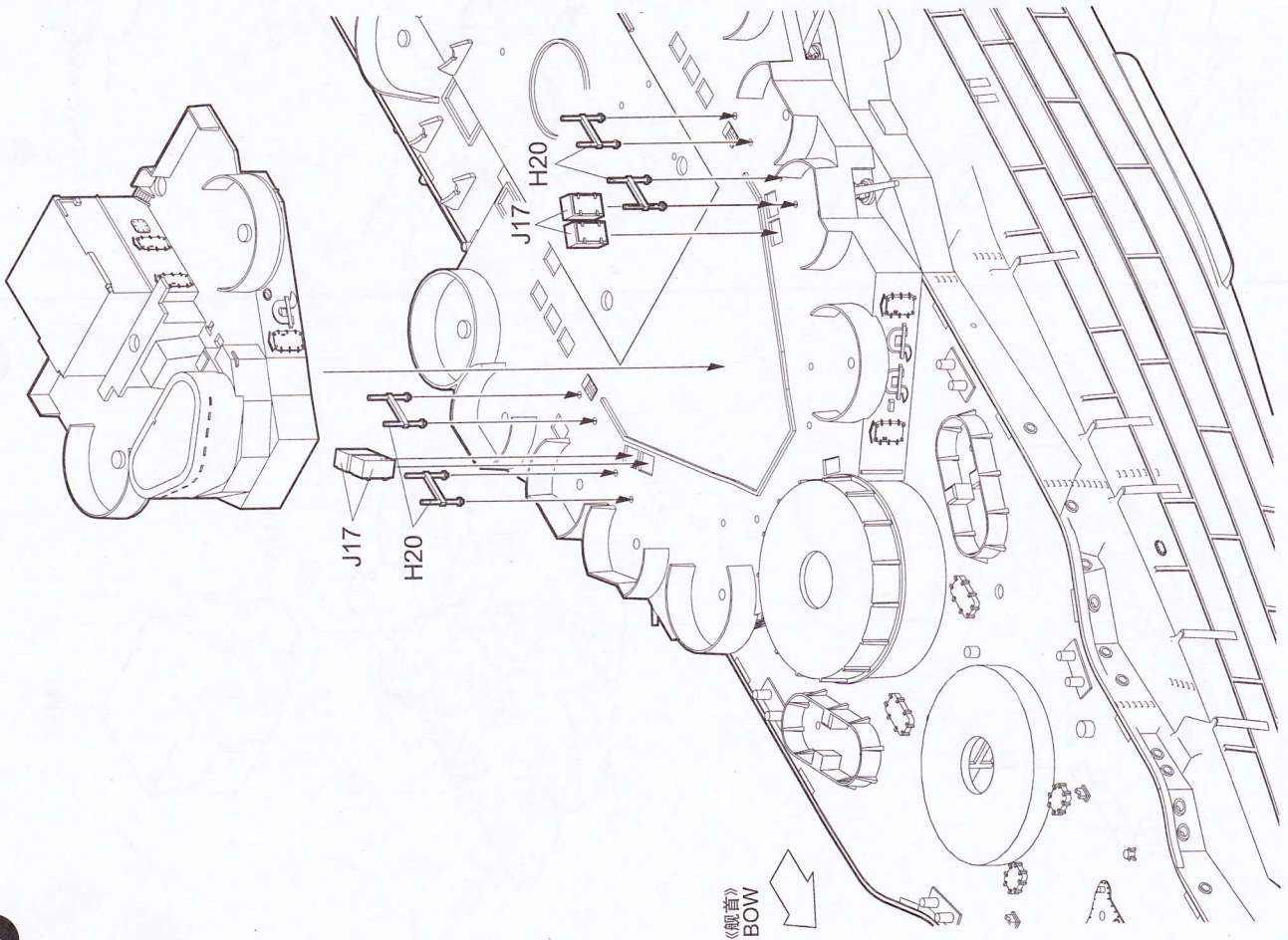

8

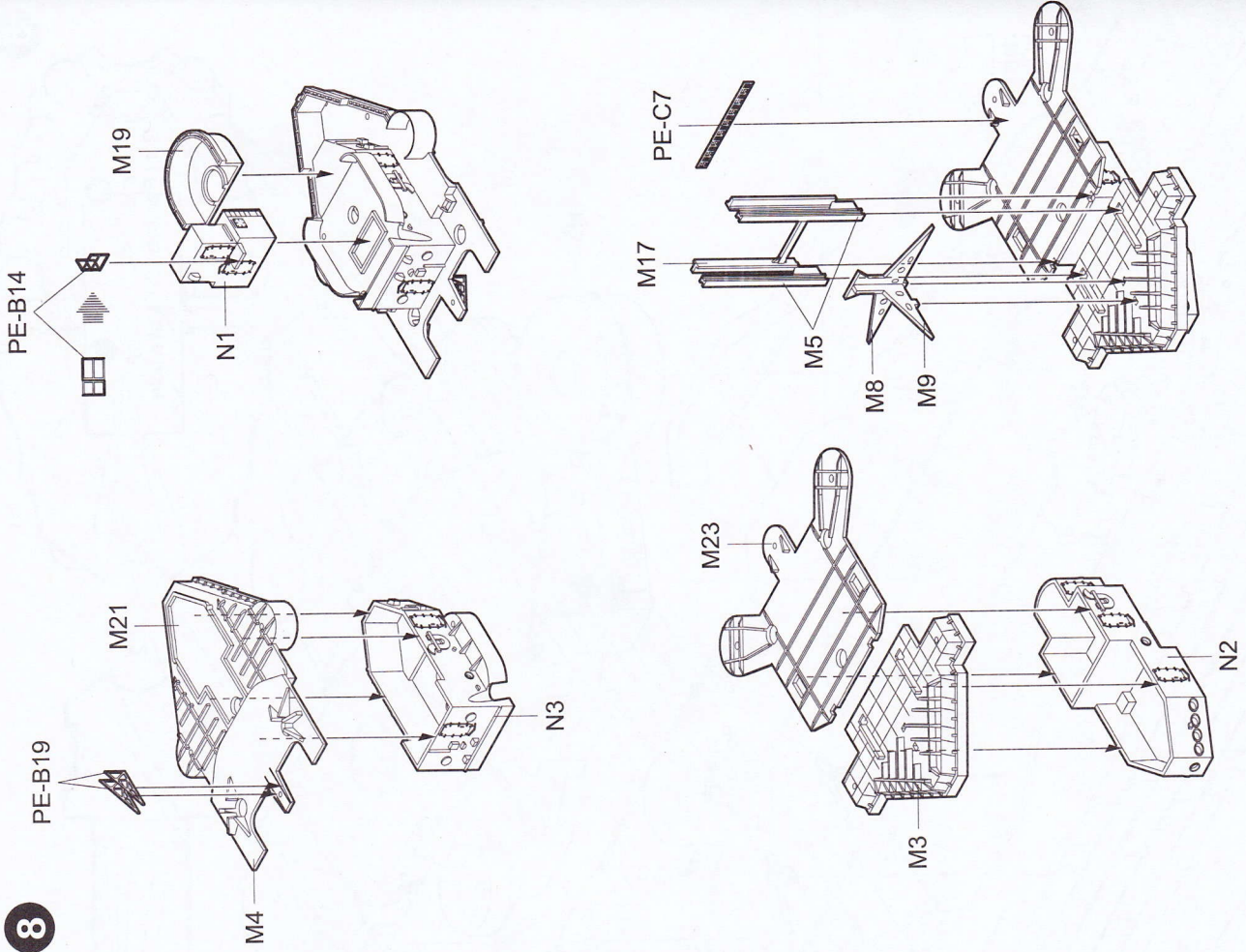

8

9

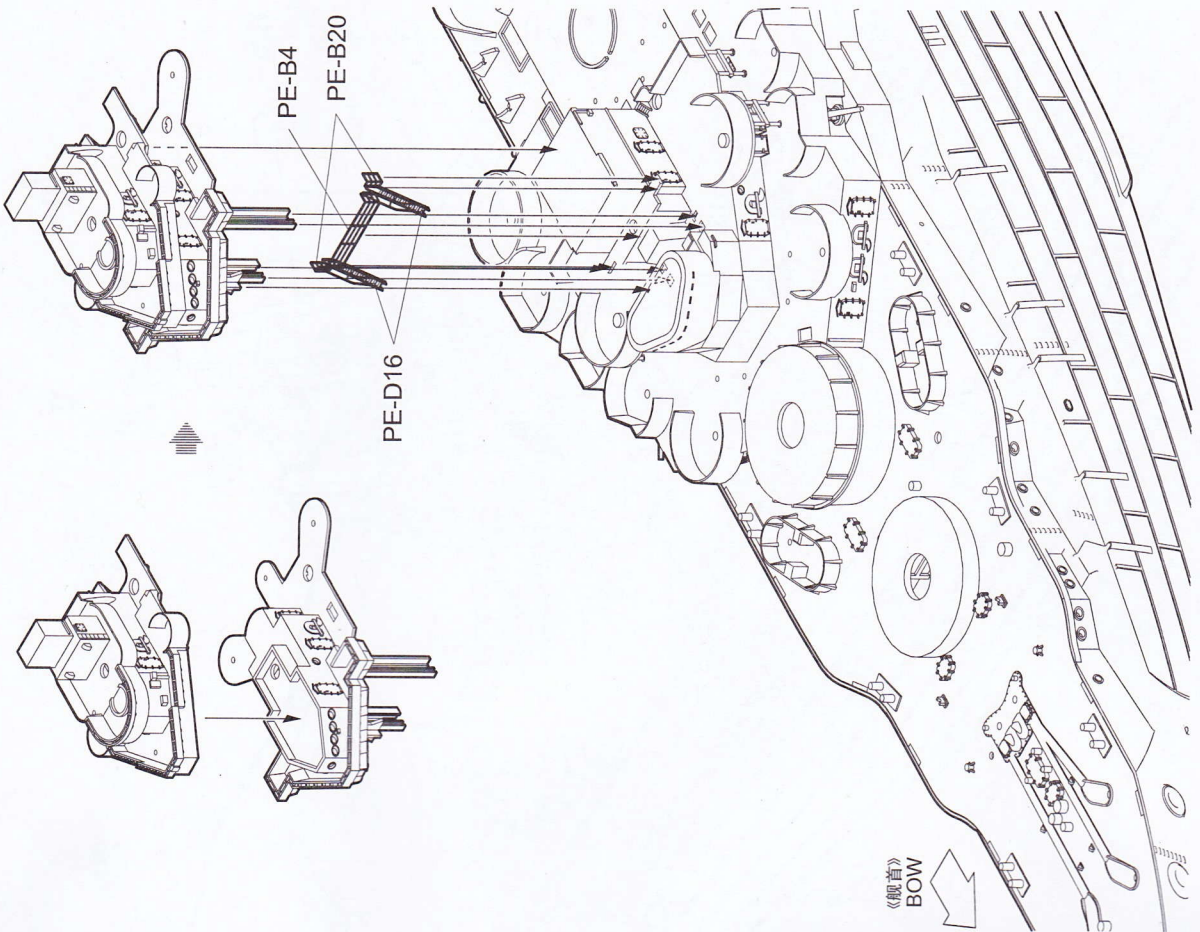

05340

9

10

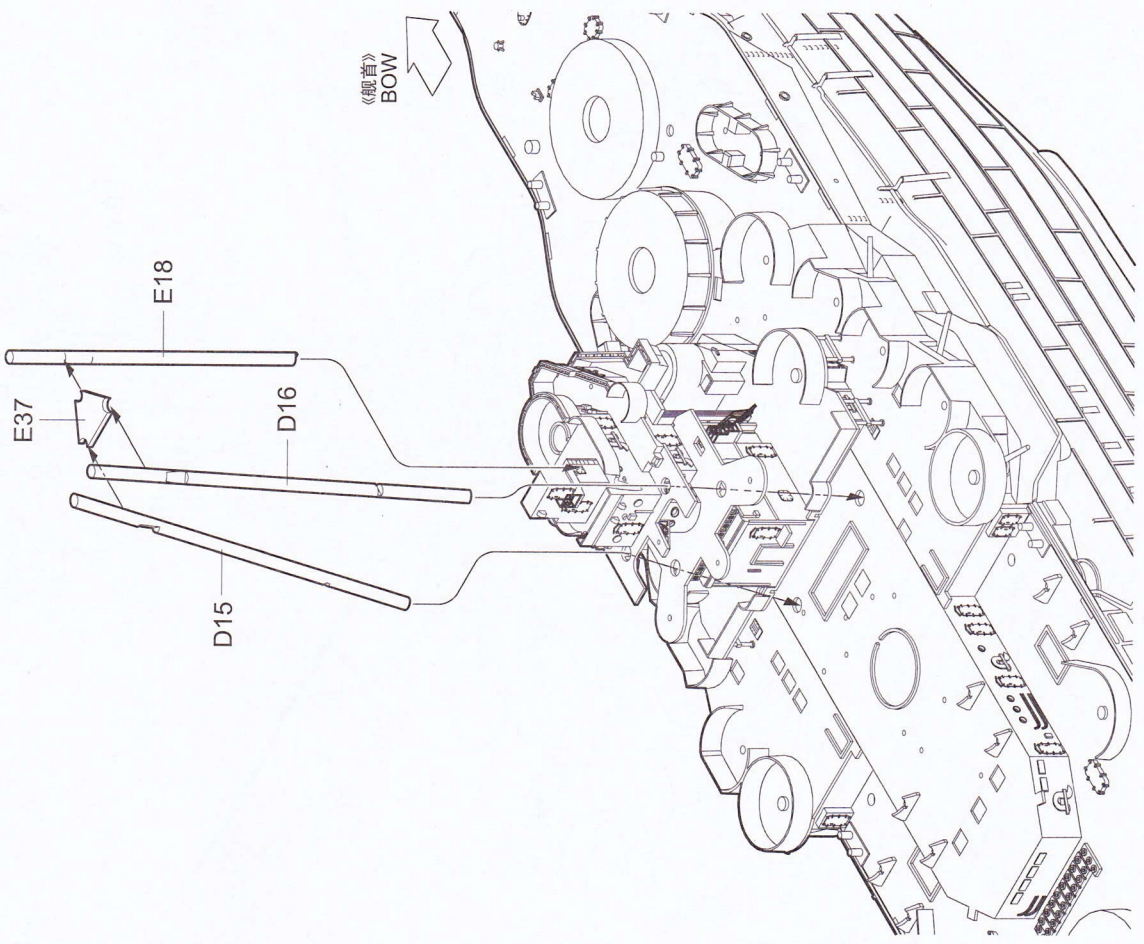

11

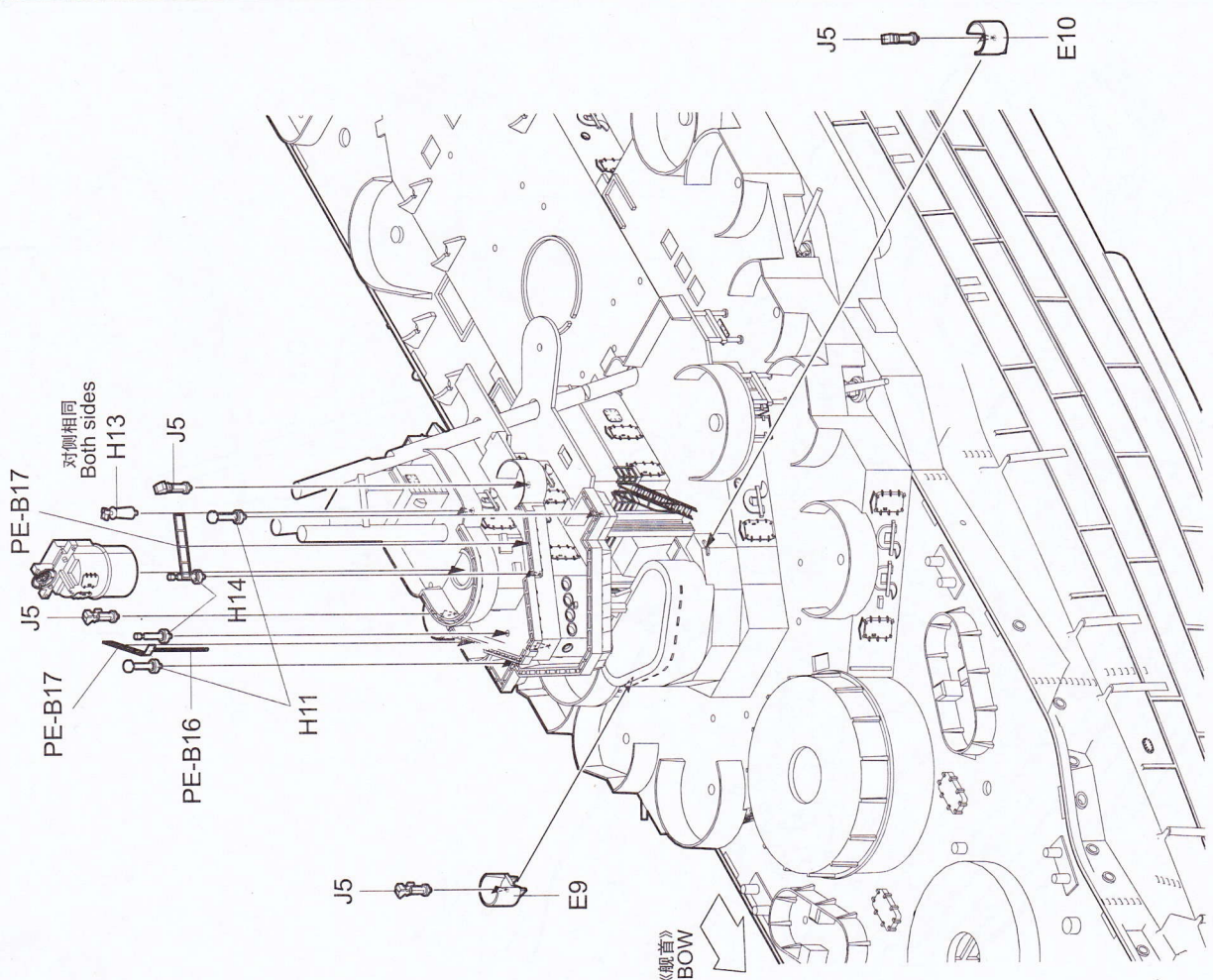

05340

12

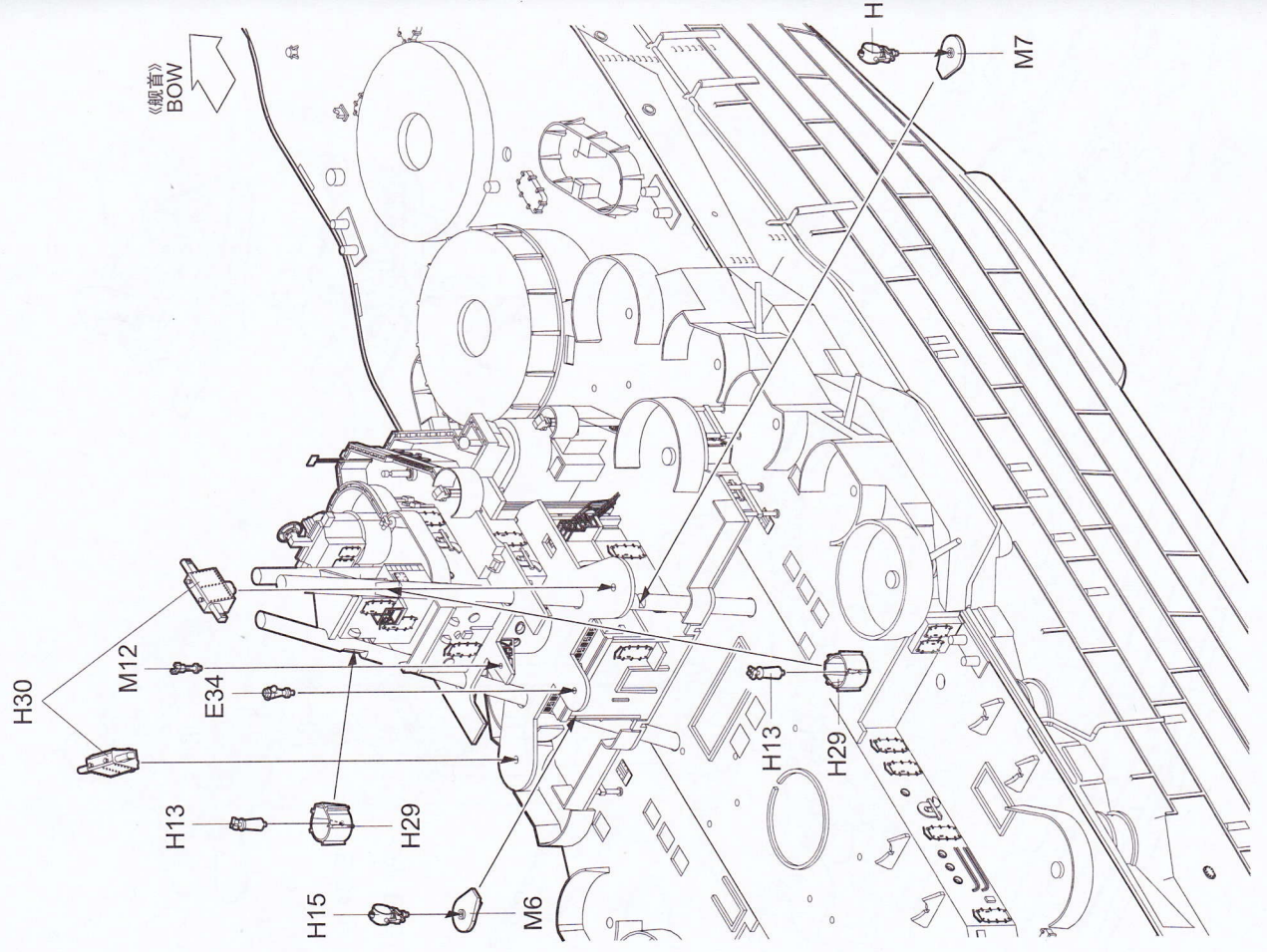

10

13

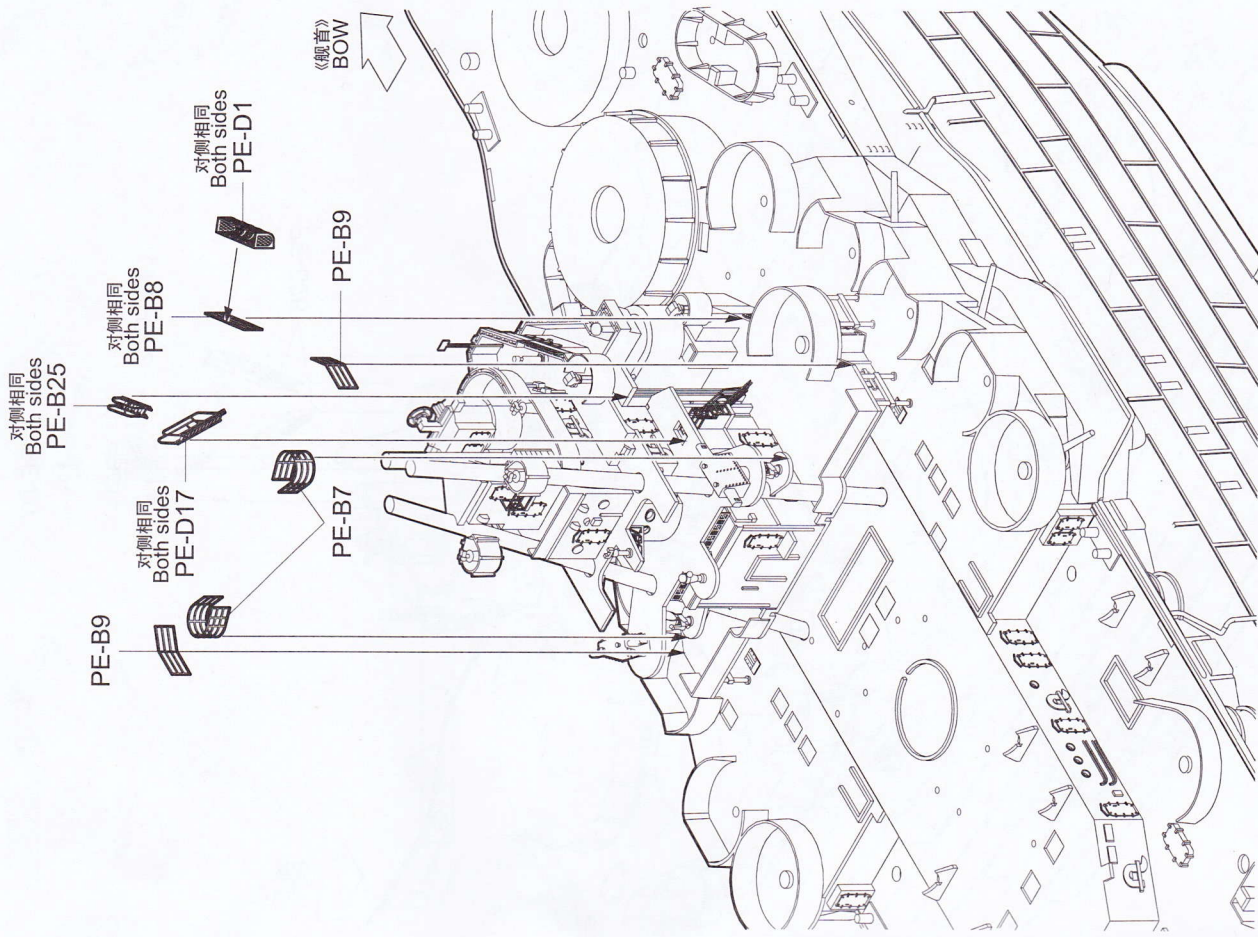

05340

14

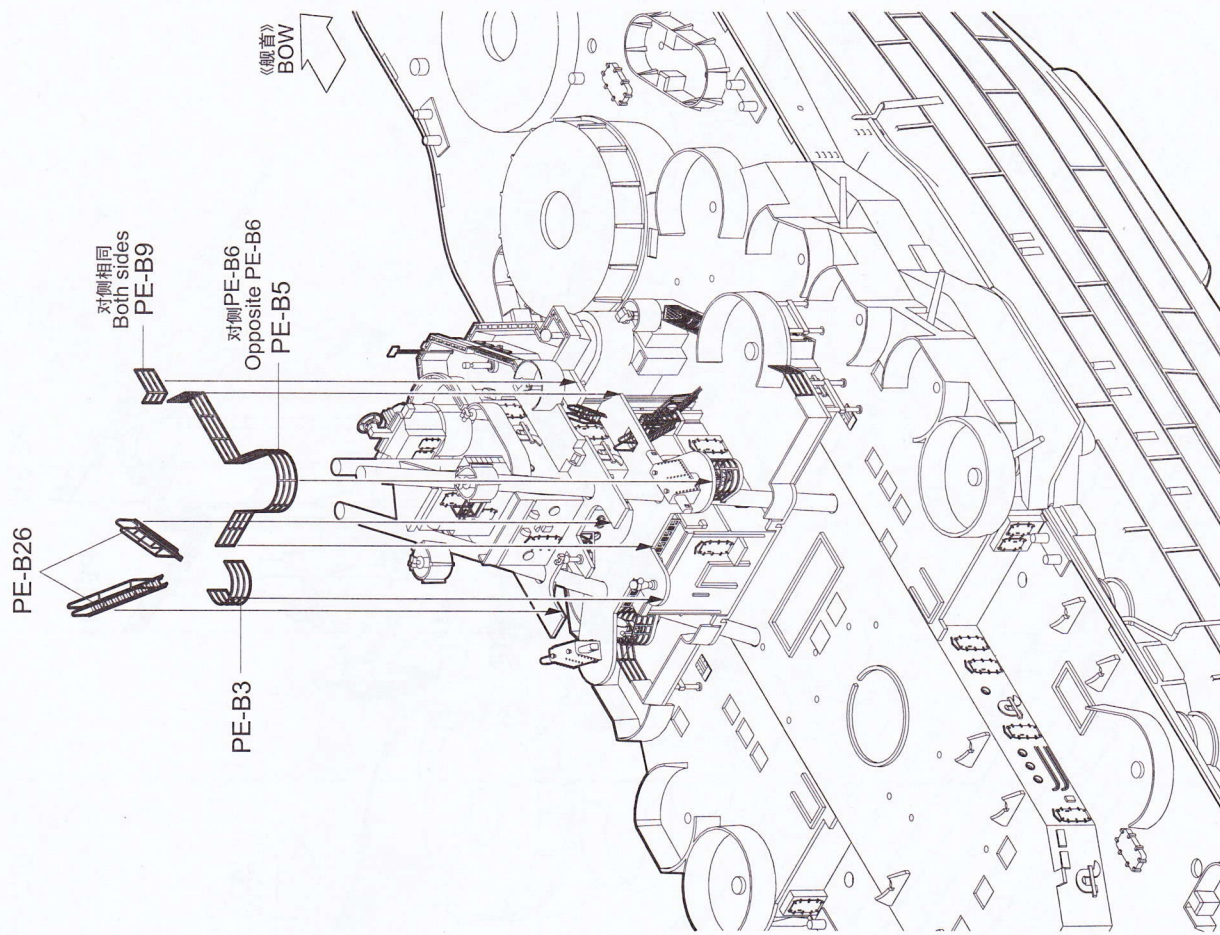

11

15

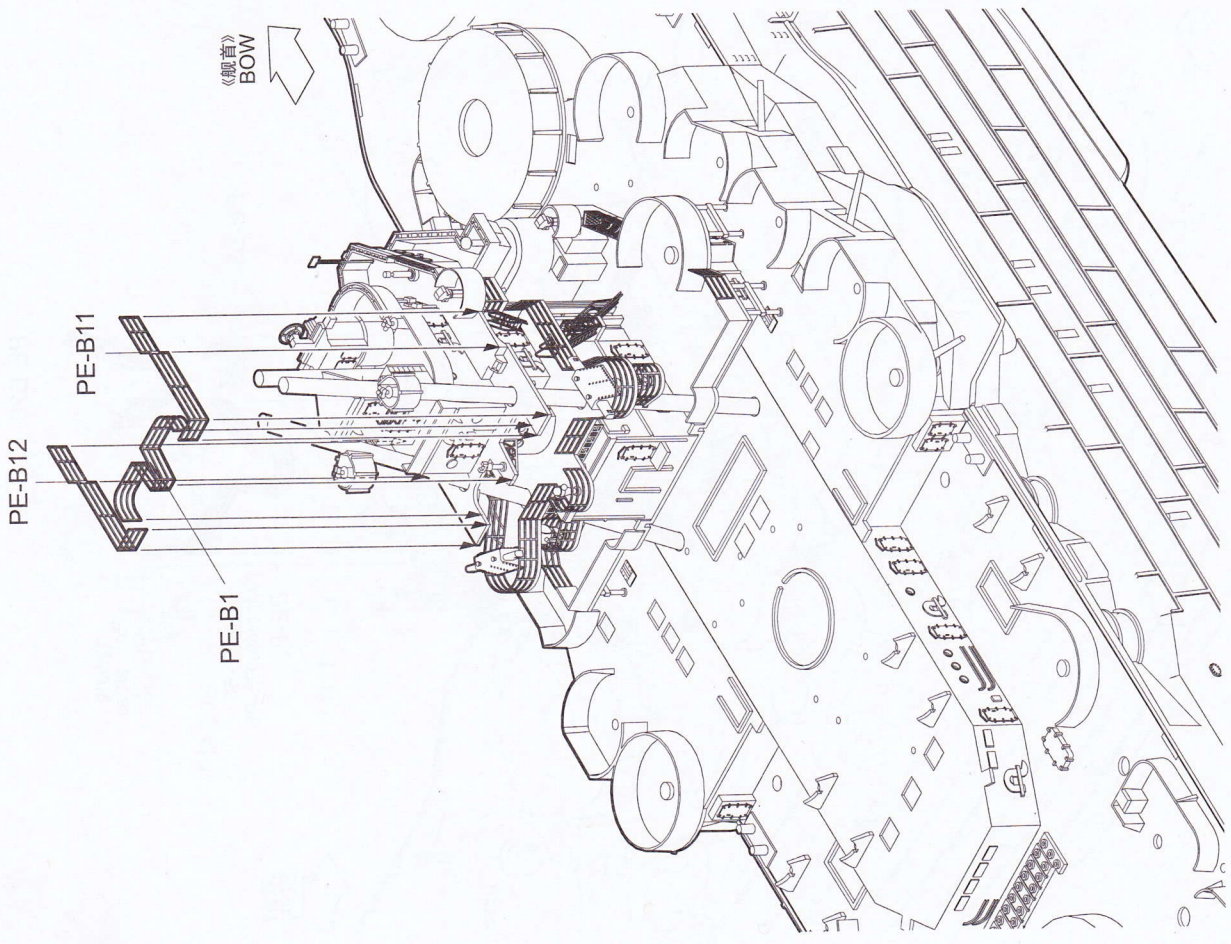

16

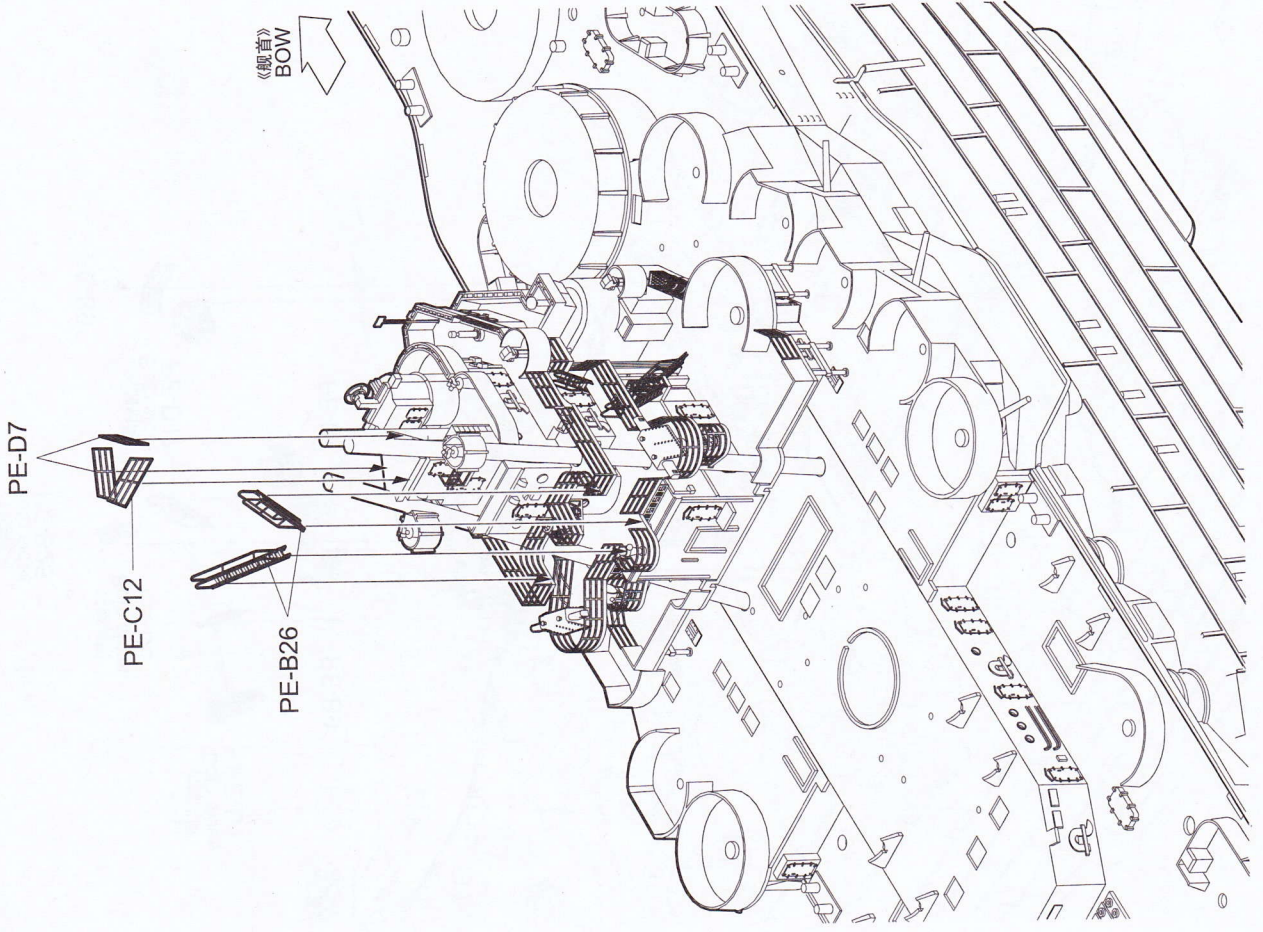

19

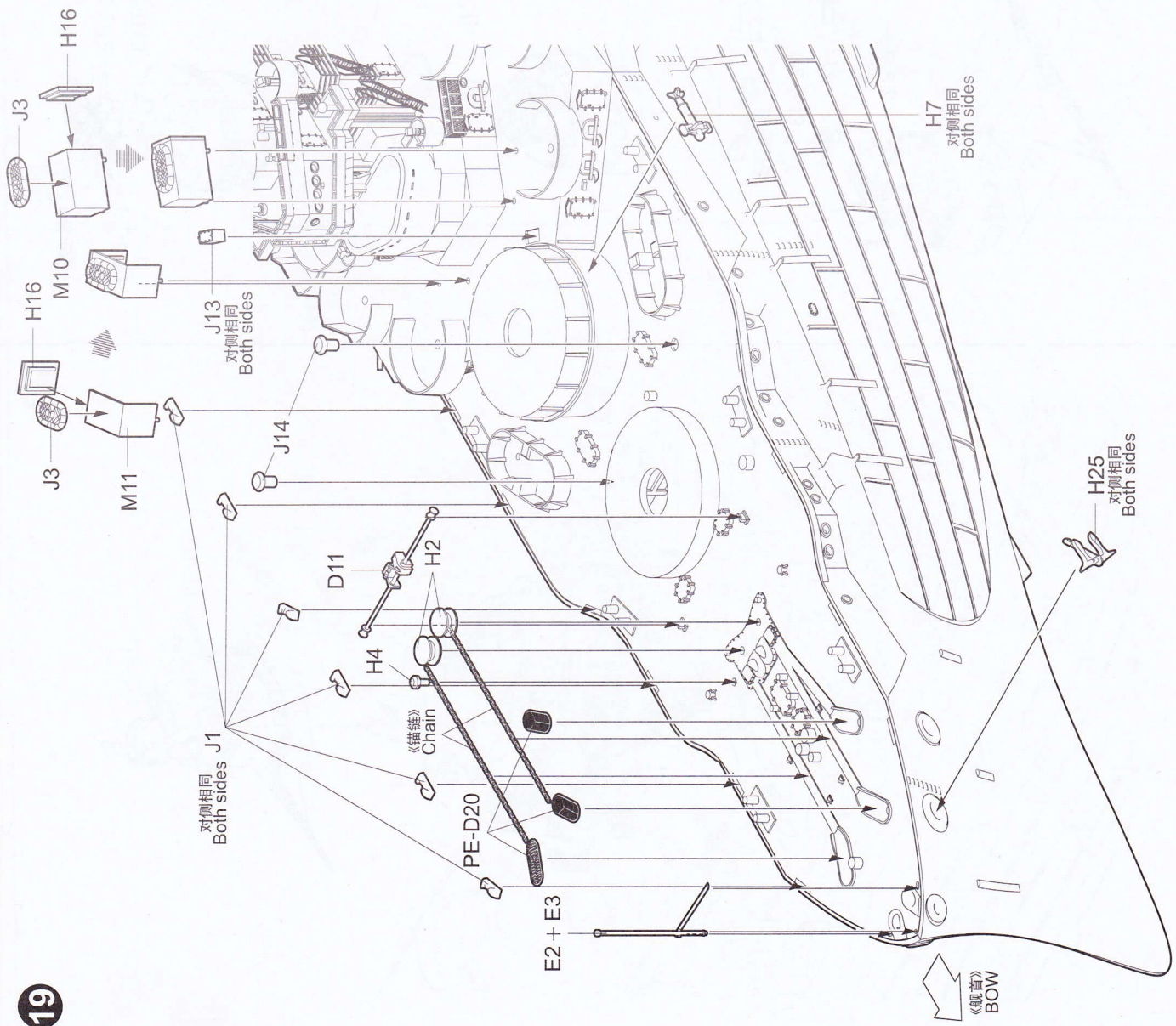

05340

14

20

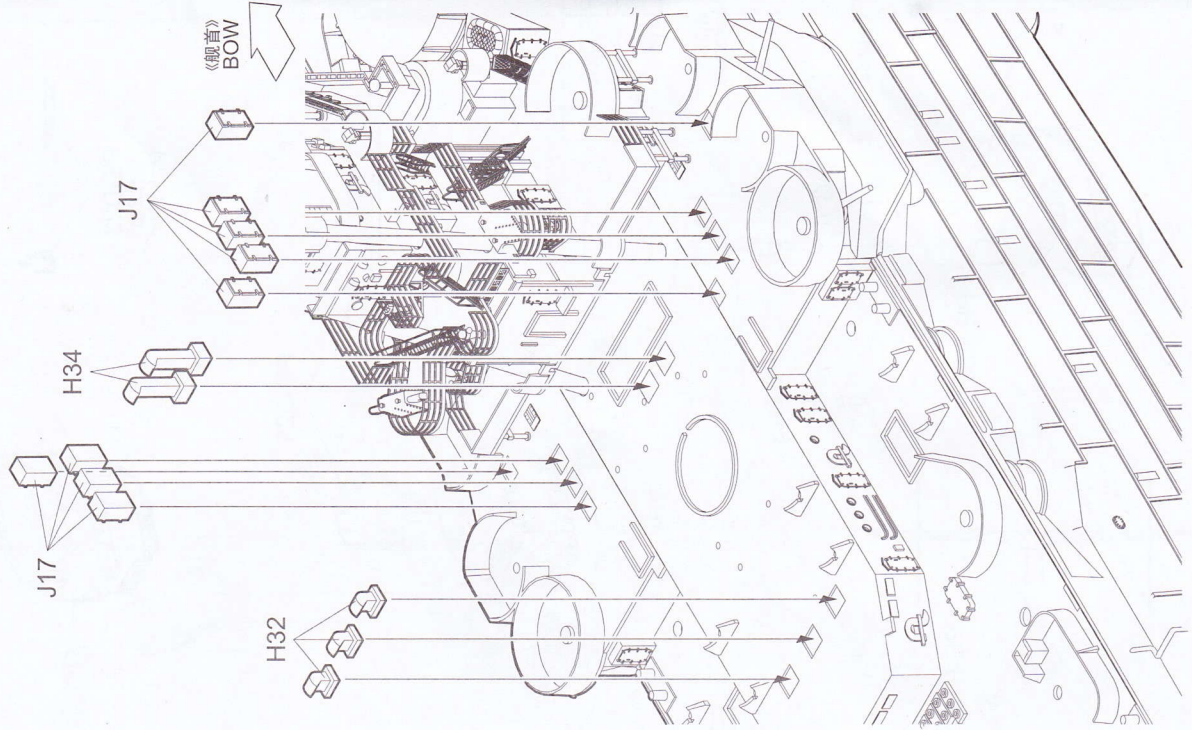

14

21

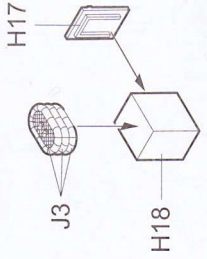
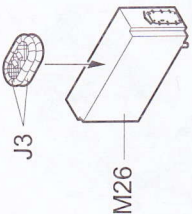

制作2套
Make two

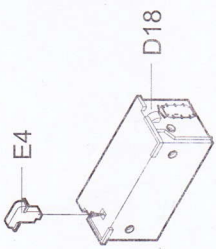
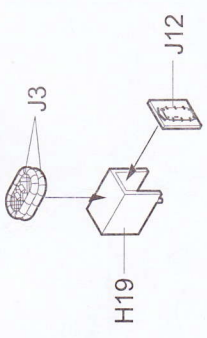
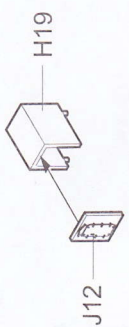
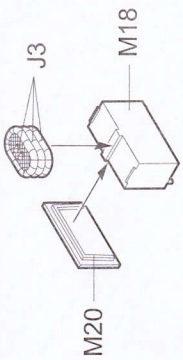

22

两侧相同
Both sides

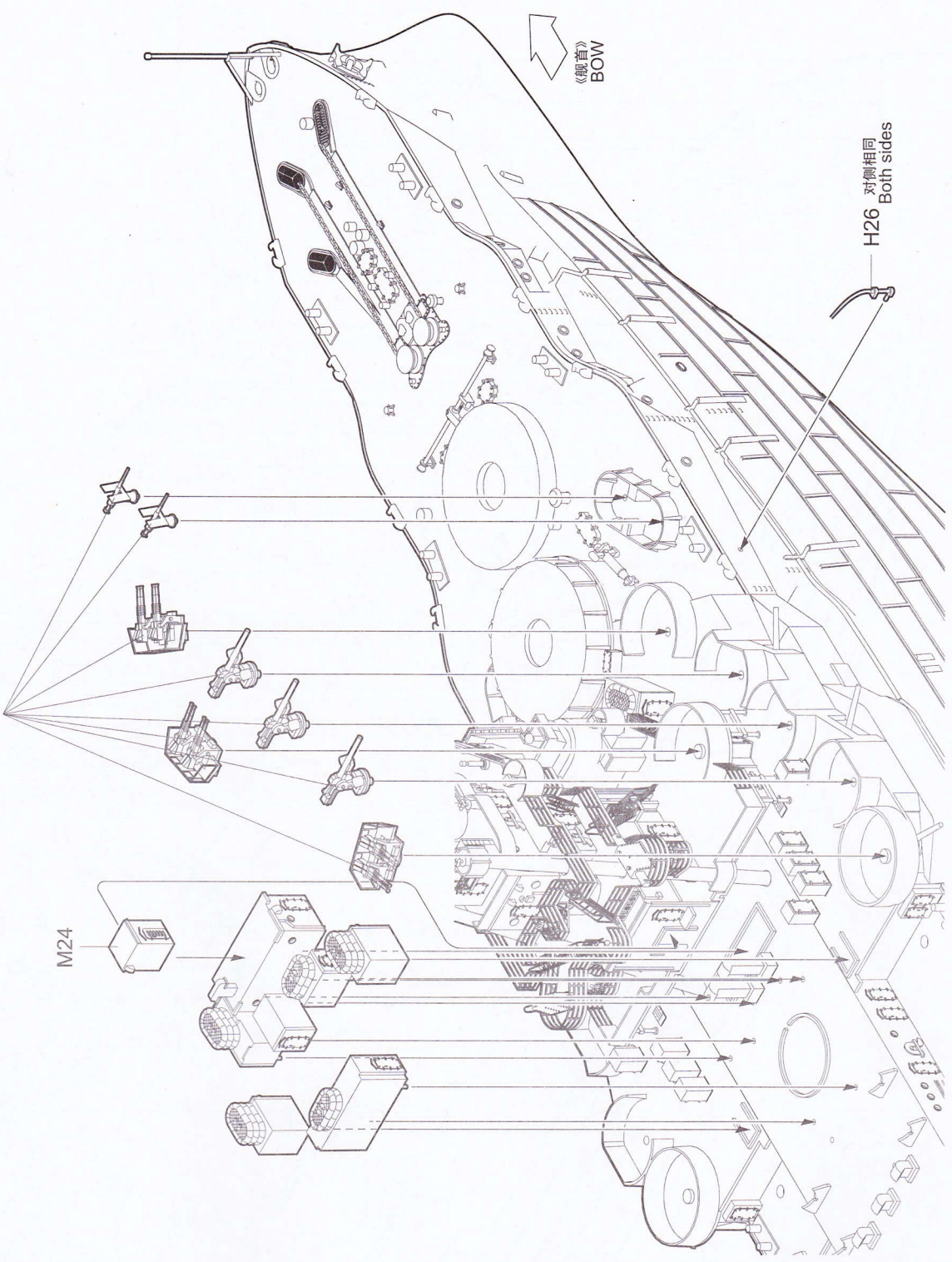

H26 两侧相同
Both sides

24

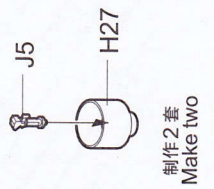
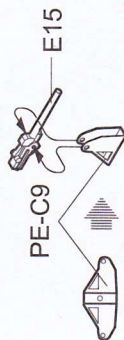
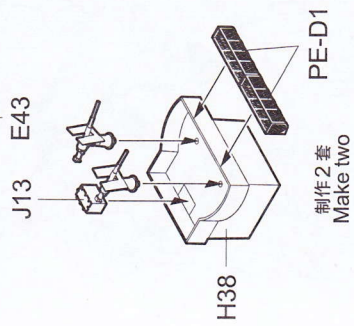
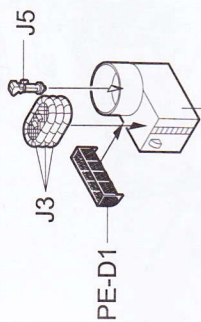
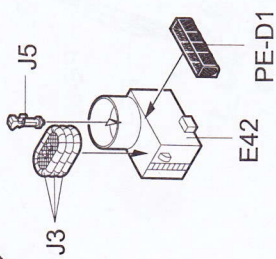

25

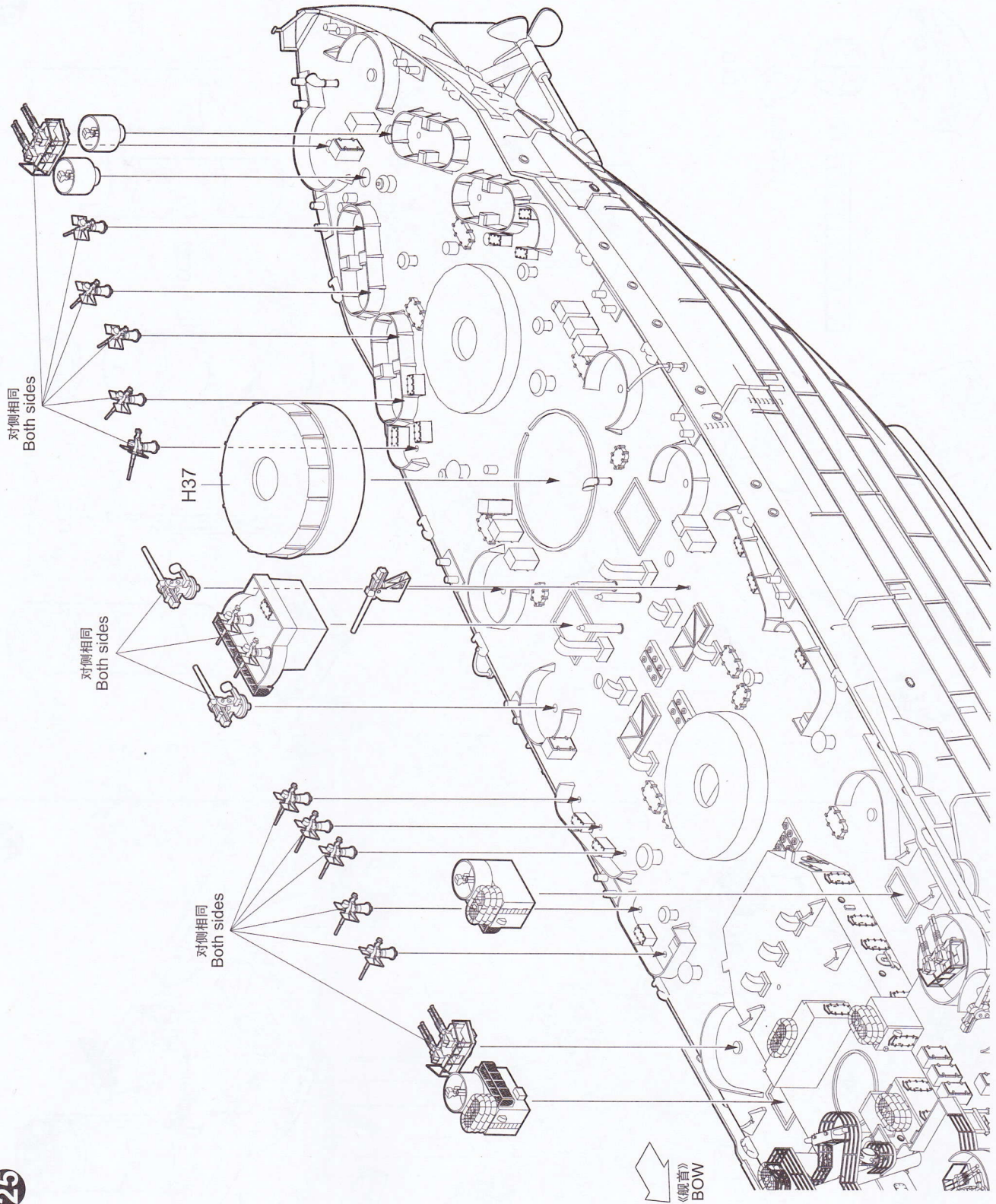

26

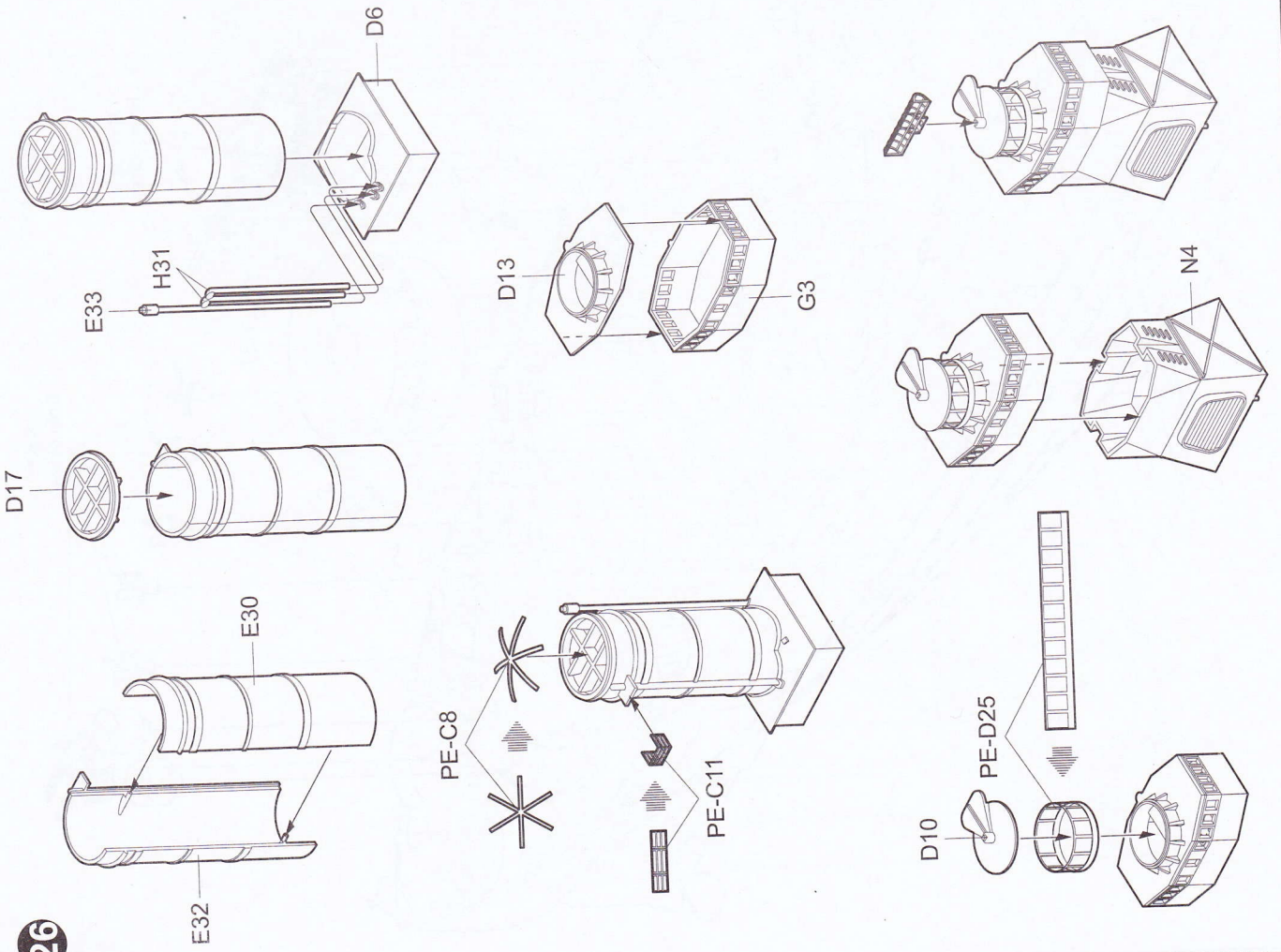

05340

27

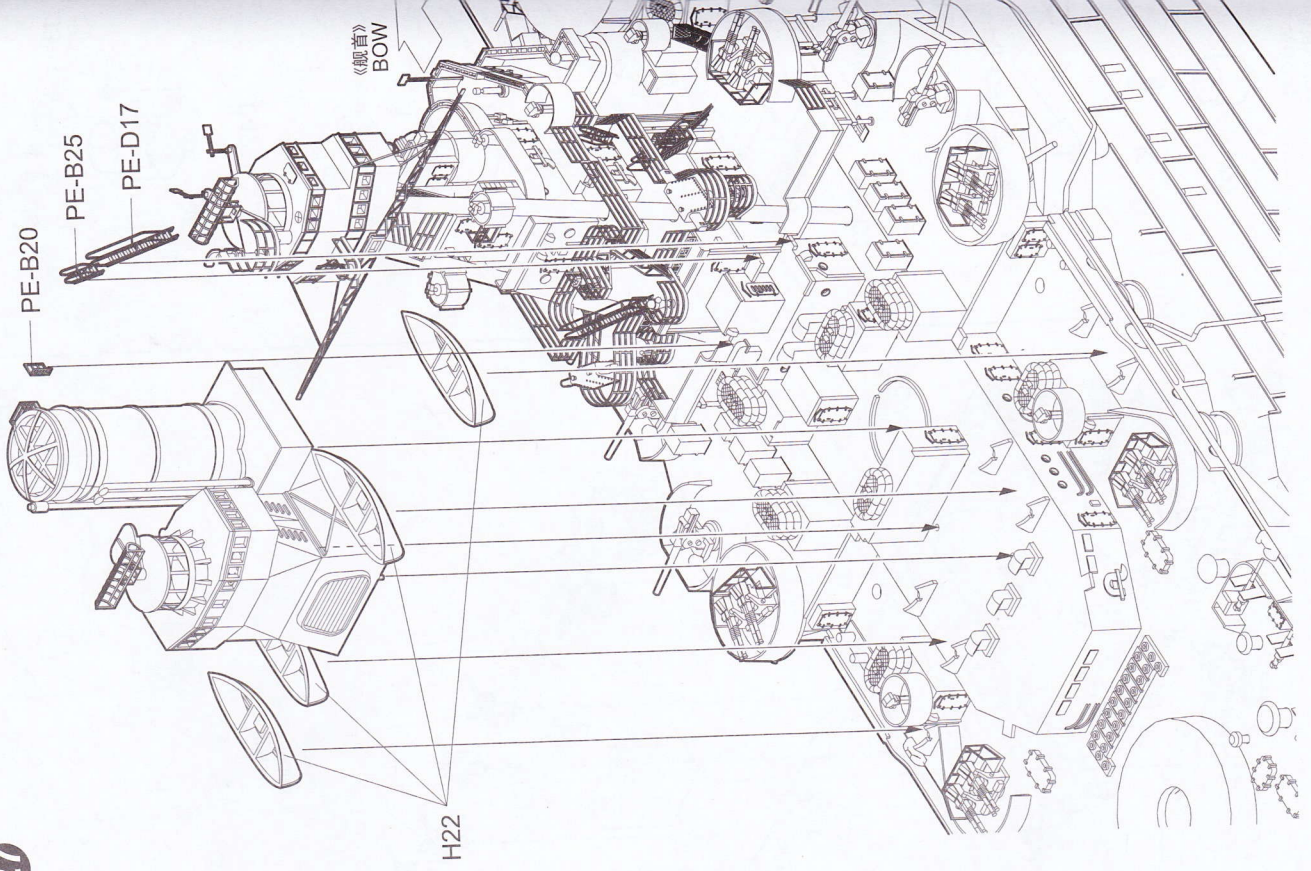

18

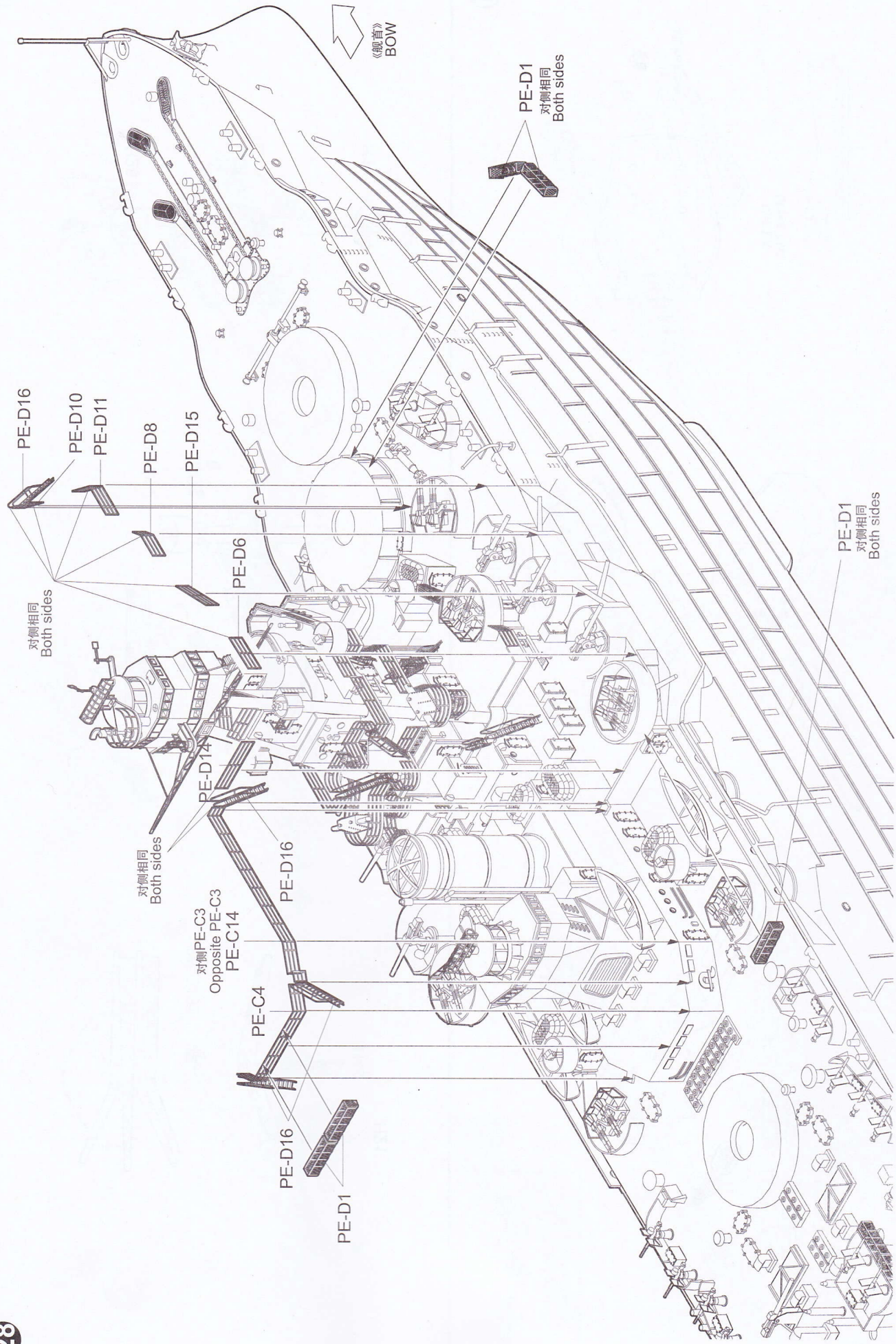

29

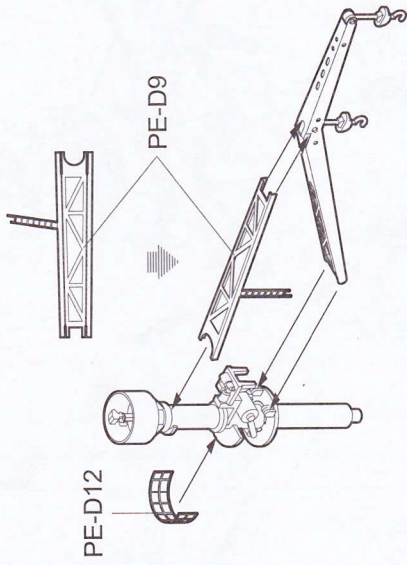
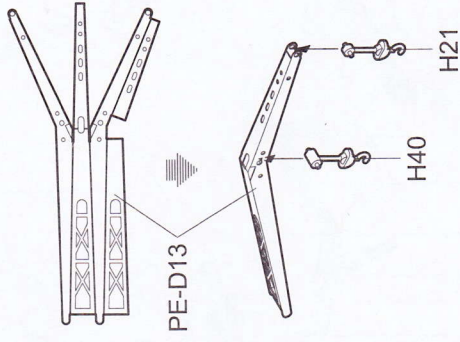
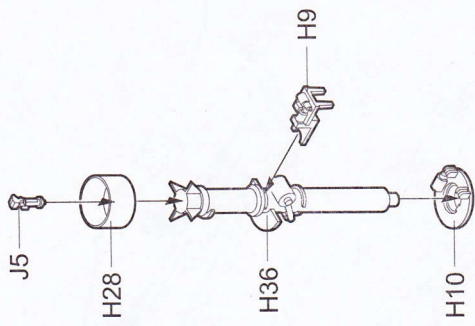

制作 2套
Make two

30

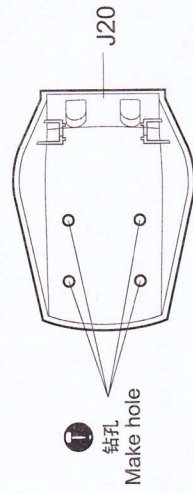

制作 2套
Make two

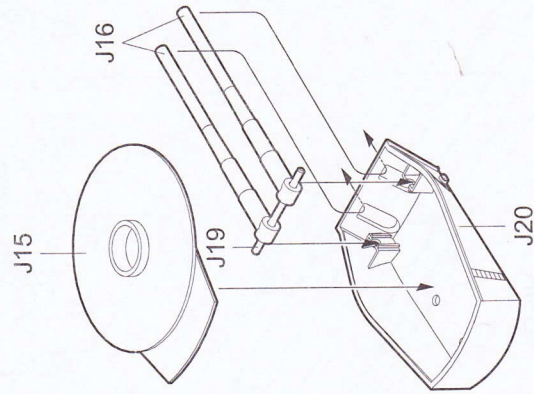

制作 5套
Make five

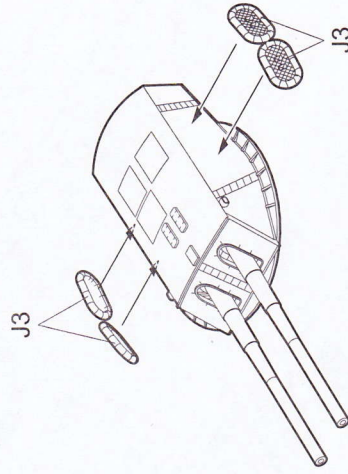

31

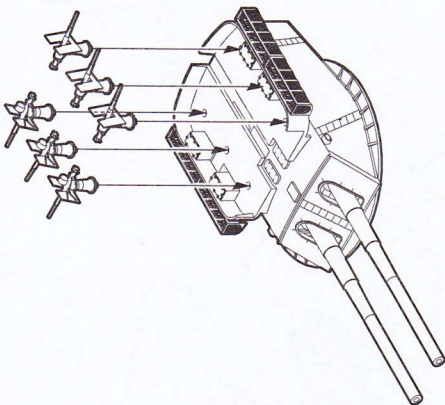
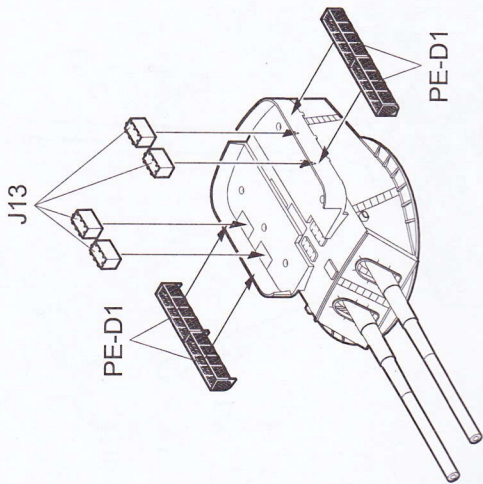
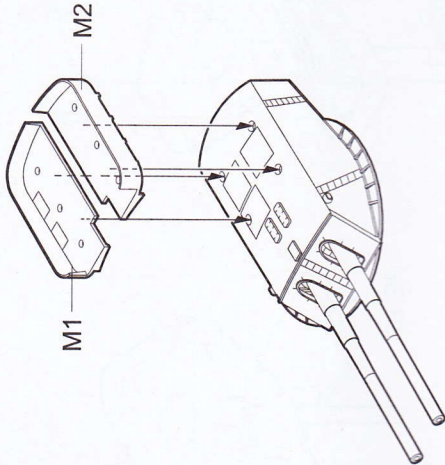

制作2套
Make two

32

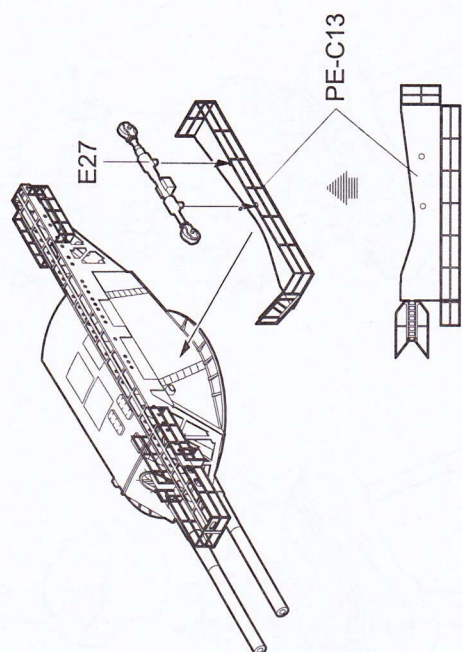
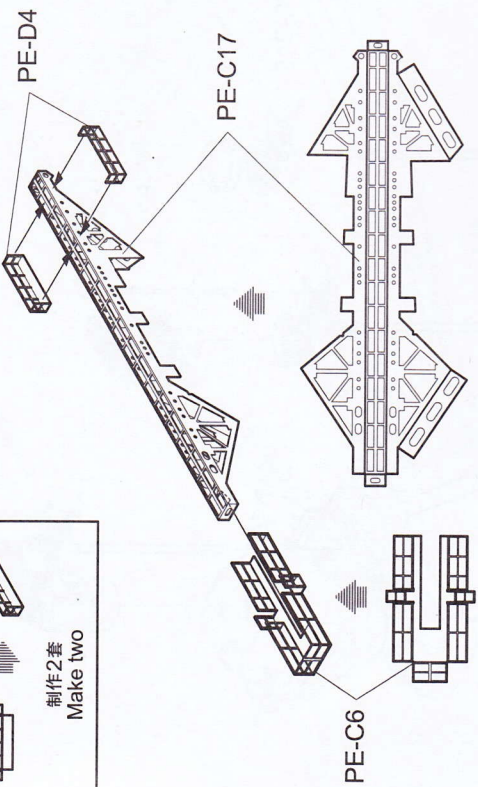
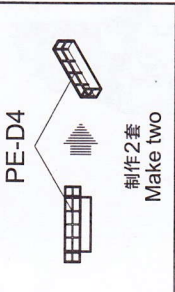

05340

21

33

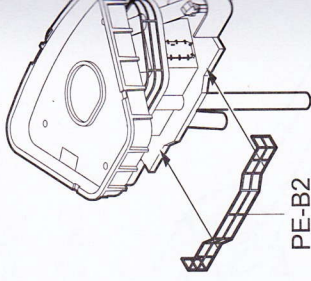
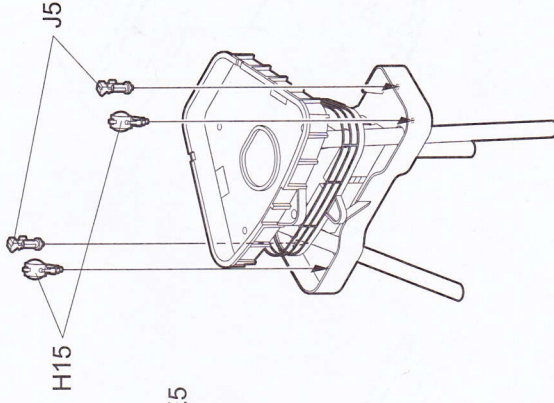
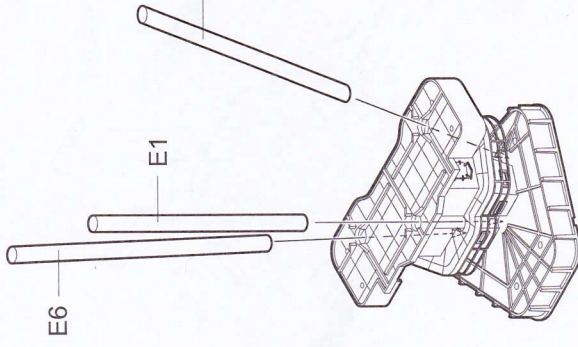
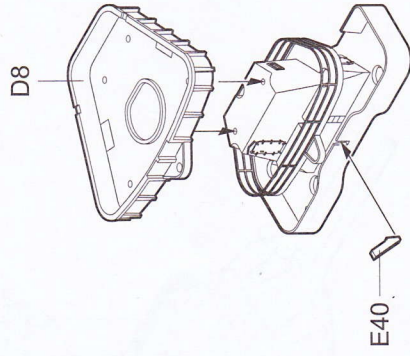
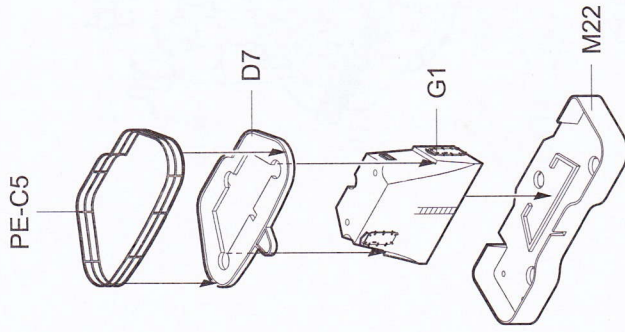

34

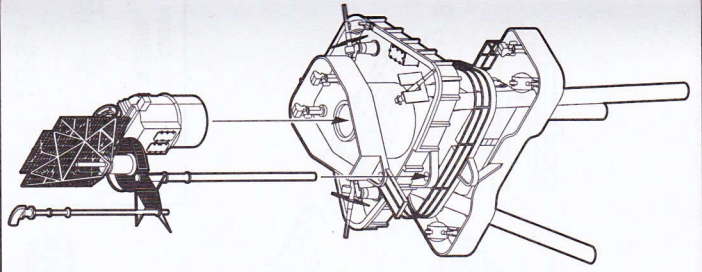
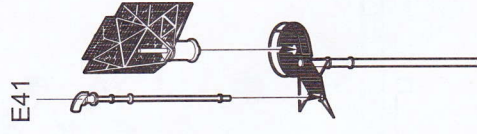
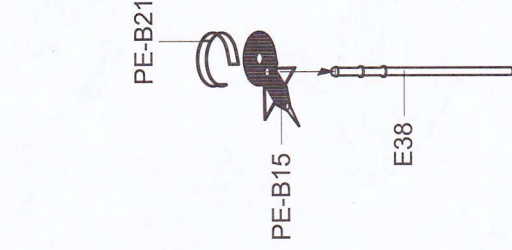
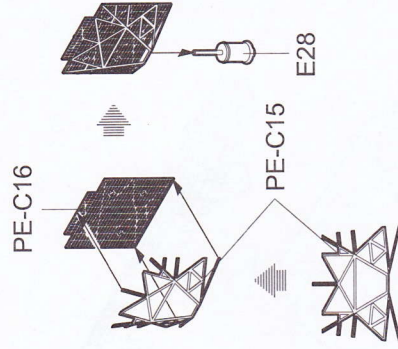
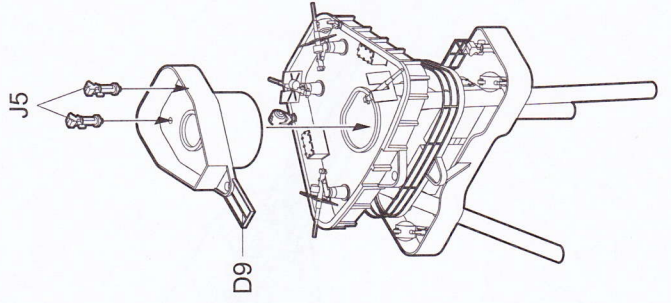
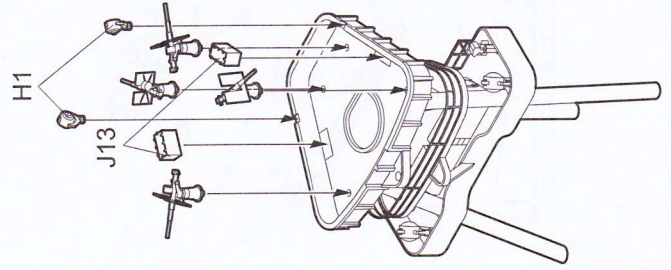

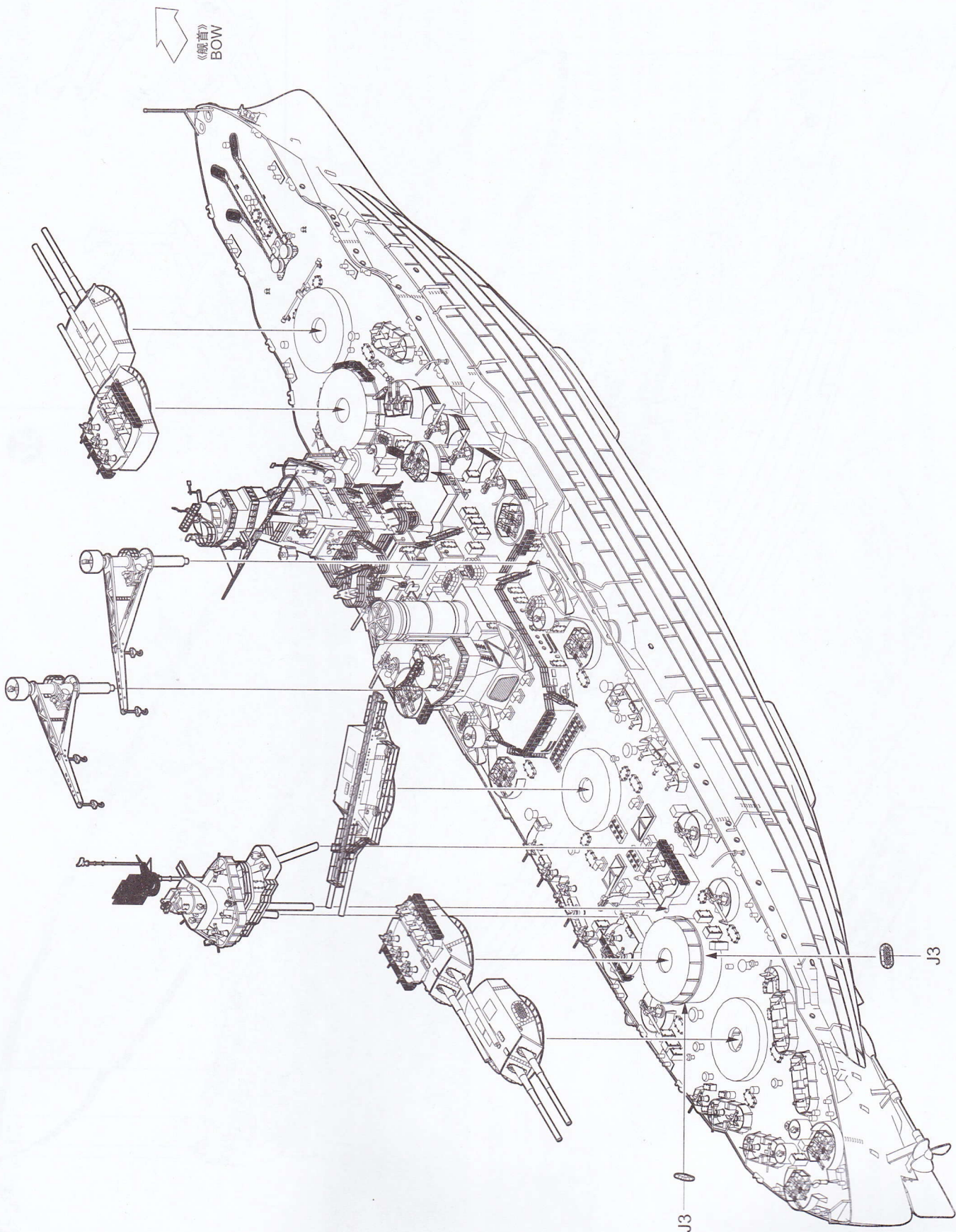

Assembly of Os2u-1

36

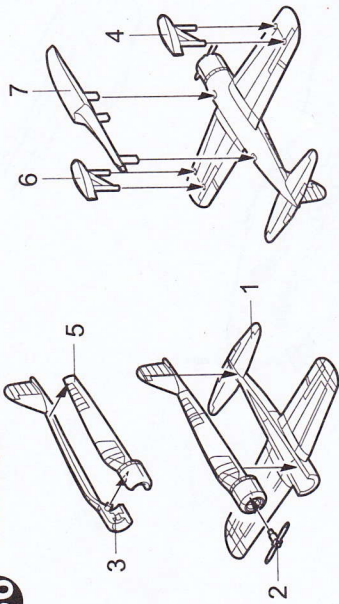

37

