

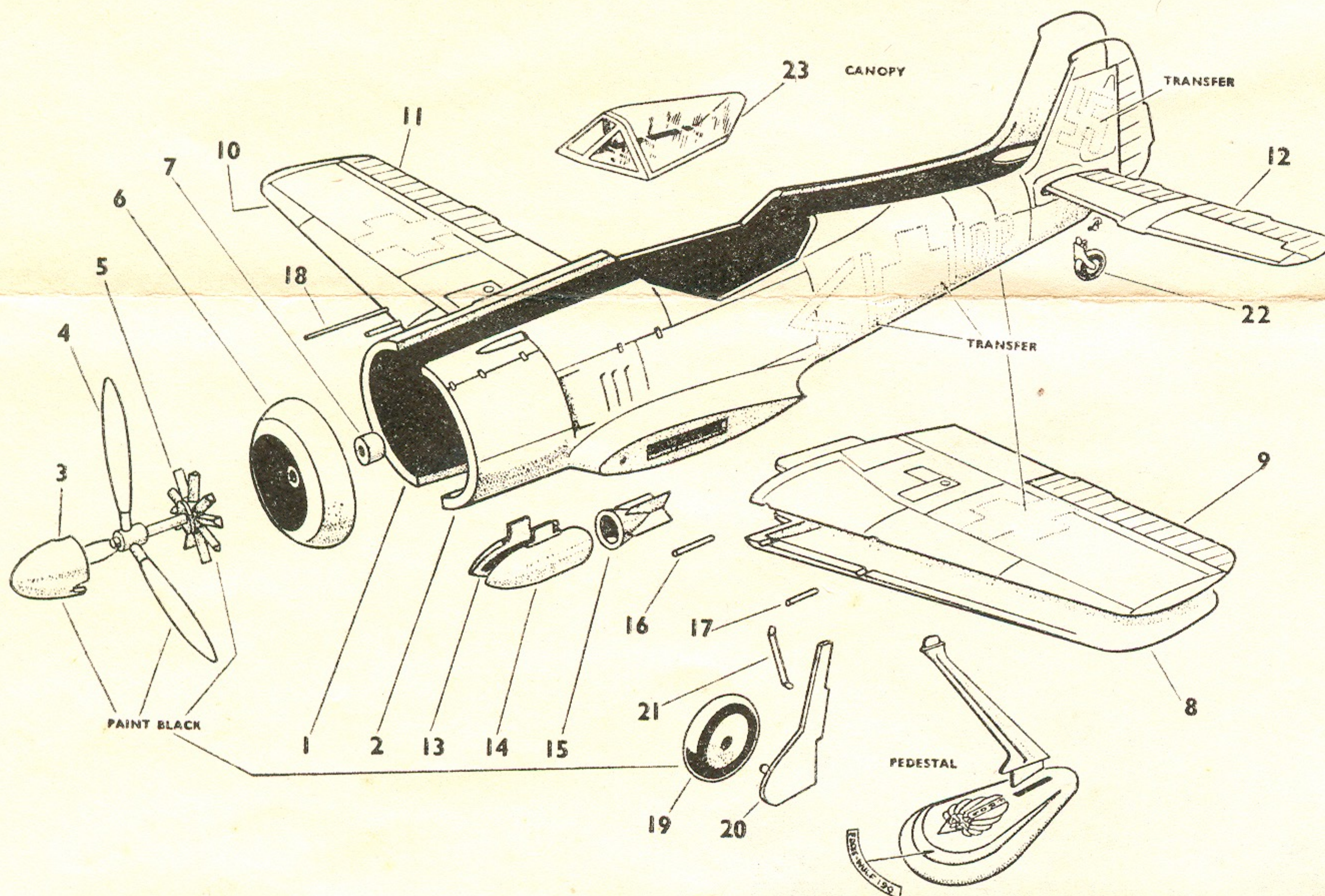

FOCKE WULF 190

SINGLE SEAT FIGHTER AND FIGHTER - BOMBER



NOTE: Very little cement is needed to hold parts together. Use it sparingly (be sure to keep it away from 'plane's outside surfaces) and you will produce a very neat model.

To open capsule of cement snip off end with scissors and squeeze gently onto surface to be adhered. Excessive pressure on the capsule should not be used as too much cement will exude from the capsule. Squeeze paint onto palette before using. Thin with Turps.

ASSEMBLY INSTRUCTIONS

1. First cement the fuselage halves (1) and (2) together, using elastic bands to hold them until they are set.
2. Next cement spinner (3) to airscrew (4) and assemble to fan (5), cowl (6), cementing collar (7) to end of shaft.
3. Cement wing halves (8) and (9); (10) and (11) together, and cement them into fuselage slots.
4. Slide tailplane (12) through slot in fuselage, and cement it carefully on the underside.
5. Assemble the halves of the bomb (13) and (14) and tailpiece (15), and leave to dry.
6. Cement the guns (16) and (17), and probe (18) into slots into leading edges of wings.
7. Assemble the wheels (19) to legs (20). Touch the ends of axles with a hot knife-blade to retain wheels. Then cement legs into slots under wings, and fit struts (21) between the legs and wings.
8. Cement tailwheel (22) and bomb in place.
9. Carefully cement canopy (23) to fuselage and paint in detail lines.
10. Paint the upper surfaces of the model dark green or dark grey and under surfaces sky-blue, unless it is moulded in this colour.
11. After painting, apply decal transfers as shown on drawing.
12. Cement pedestal parts together, and apply name transfer. Fix model to pedestal.

When the F.W.190 first went into squadron service with the Axis forces in France during 1941, it immediately gained superiority over the Allied fighters at that time, its main assets being extremely good manoeuvrability and speed. The A-4 version on which this model is based, carried a 550 lb. bomb under the fuselage for ground attack missions. Armament was four 20 m.m. M.G. 151 cannon in the wings, and two 7.92 m.m. M.G. 17 Machine-Guns in the fuselage cowl, four 60 lb. bombs were sometimes carried under the wings. The 190 was fitted with a BMW 801 D. 14-cylinder radial air-cooled engine of 1,600 h.p., and its loaded weight was 9,750 lbs. Speed was approx. 400 m.p.h. boosted to 416 m.p.h. for short periods. Wingspan 34' 5½"; Wing area 196 sq ft.; Length 29' 0"; Service Ceiling 37,000 ft.

There are many other excellent models in this Frog range.

