

Lifelike Decals

✓ 48-001/ ~~72-001~~

Limited Edition!

Focke Wulf Fw 190 Part 1

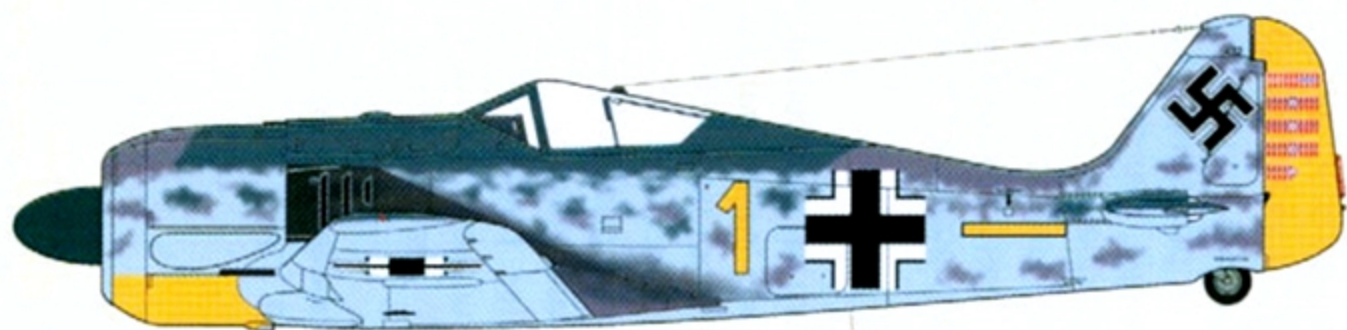

Erich Rudorffer, 6/JG 2

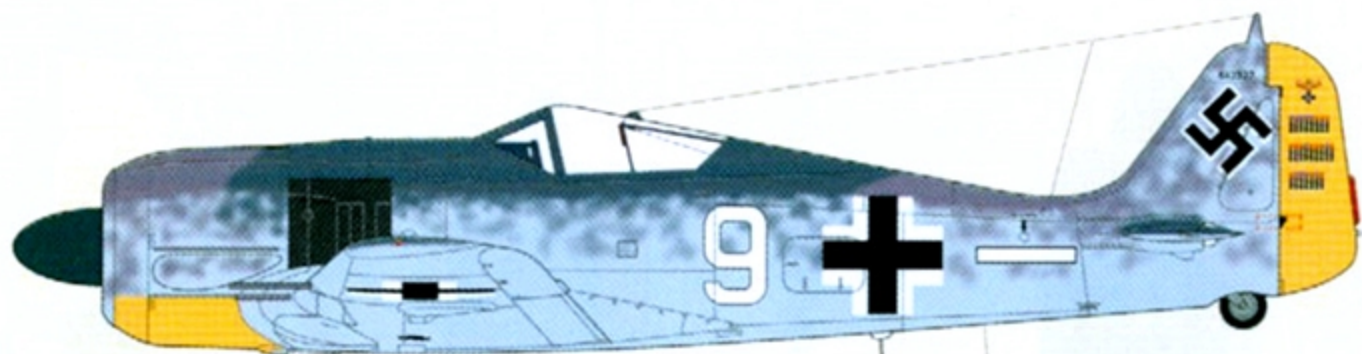

Adolf Glunz, 5/JG 26

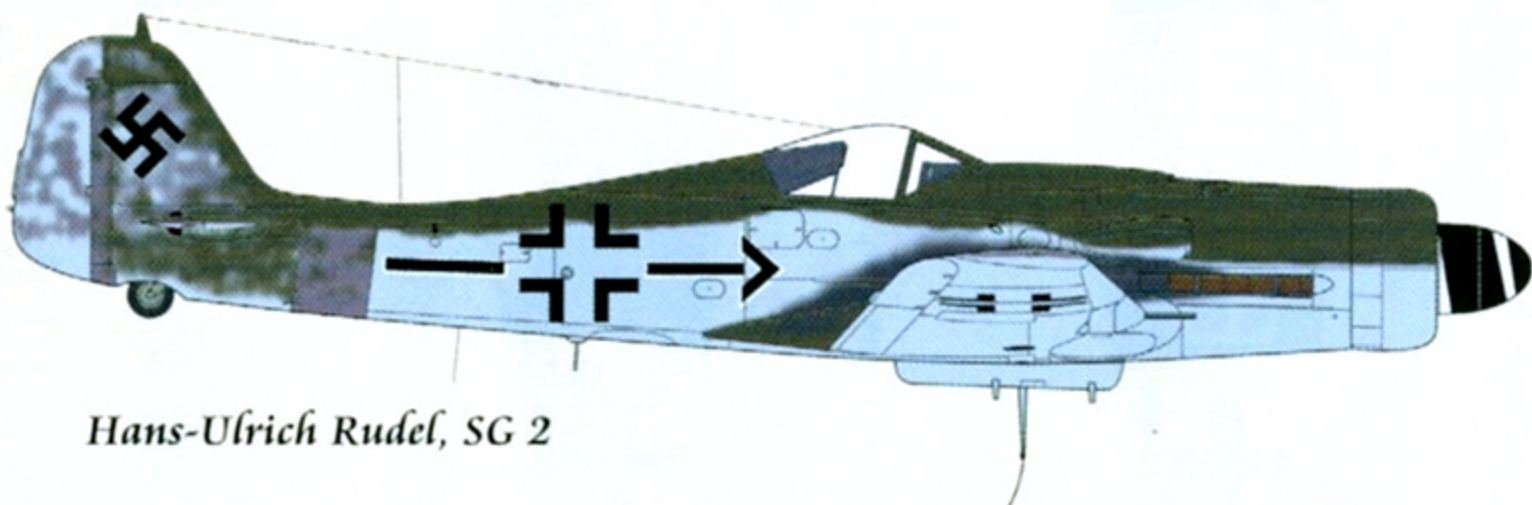

Hans-Ulrich Rudel, SG 2



Günter Rey, 11/JG 54

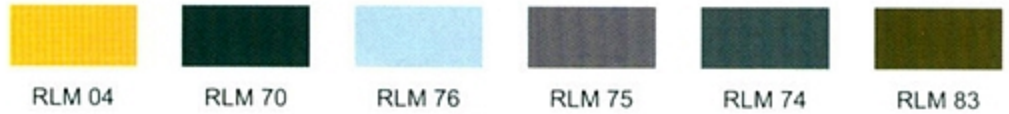

(1) Fw190 A-3 flown by Oblt. Erich Rudorffer, Staffelkapitän 6/JG2, Beaumont le Roger/France, August 19, 1942.

Camouflaged in the standard gray scheme of RLM 74/75/76. Its photo in ref. 1 shows exhaust stains extend slightly beyond black painting, and some area of wing fillet. The kill bars are probably red as with his Me 109F. Kill marks on the right side of the rudder are not confirmed, and are provided here for modeller's choice. This A/C suffered a damage on its rudder

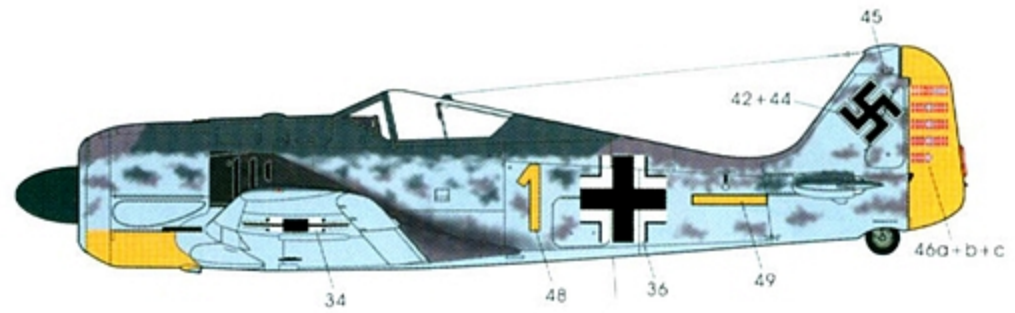

later (ref. 2). Rudorffer lived through the war with a total of 224 kills.

(2) F 190 A-7 flown by Obfw. Adolf Glunz, 5/JG26, Cambrai-Epinog/France 1943.

Camouflaged in the standard gray scheme. Though he was attached to 5/JG26 at that time, this A/C had "white 9". The style of 9 is often illustrated in the "round" shaped one (as with his later black 9, ref. 3), but the photo on p247 of ref. 1 clearly shows that it is an "angular" one. Kill marks on the right side of the rudder are not confirmed, and are provided here for modeller's choice. He was awarded

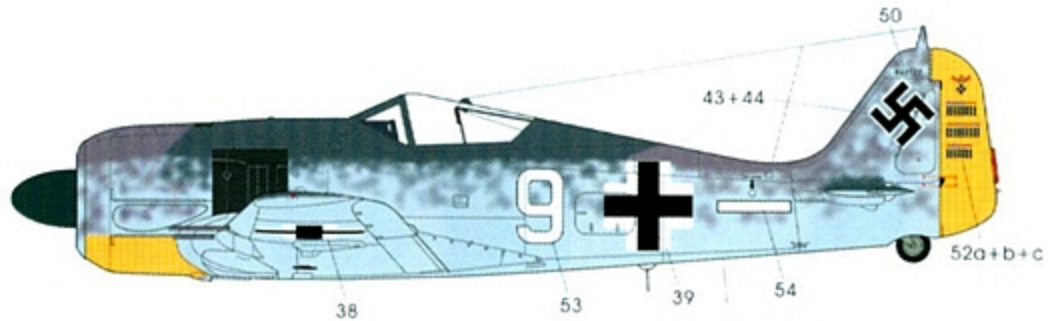

Ritterkreuz on August 29 1943 with 39 kills, and achieved a total score of 72 kills. He has a unique record of never been shot down during the combat.

(3) Fw190 D-9 flown by Oberst Hans-Ulrich Rudel, Kdore. SG 2, Grossenhain/Germany, April 1945.

Oberst Rudel, the only recipient of Golden Oak Leaves to Ritterkreuz, flew Fw190 F-8 and D-9 around the end of the war. His D-9 is shown in one poor quality photo in ref. 4, and is probably camouflaged in the customary RLM83/75/76 color. The Stab marking on his F-8 has narrow black outline (ref. 5), but that on this A/C seems to be a simpler form. Further scrutiny of the photo shows

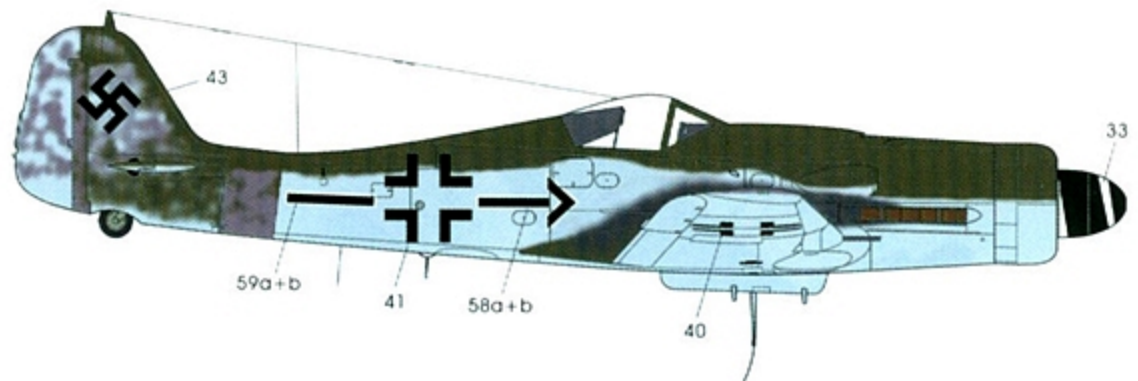

that the Stab marking is IRREGULARLY aligned which is very rare with Luftwaffe. He is credited with 9 or 11 victories.

(4) Fw190 D-9 flown by Unter-offizier Günter Rey, 11/JG54, Fürstenau/Germany, Jan. 1 1945.

We could not find the photo of this A/C, but it is shown in one article in ref. 6. The illustration shows early type canopy for this A/C. Its caption says this A/C is one of the earliest batch D-9 with W. Nr. 210xxx with a camouflage of RLM 83/75/76 with some mottle of RLM 83/81 on the fuselage side. Unter-offizier Rey received it just in time for Operation Bodenplatte. Due to limited time only III/JG54 emblem and Rey's personal

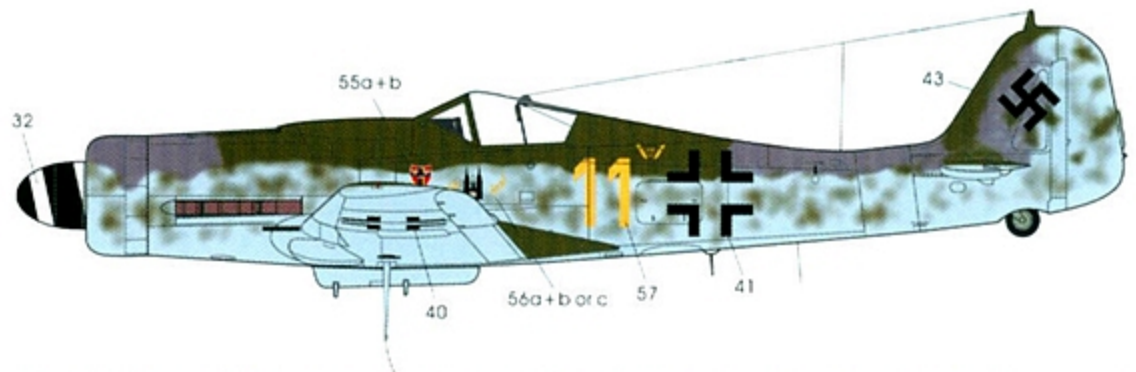

marking (Cologne Cathedral) was applied, but not the blue RVD band for JG54. Cologne coat of arms in the illustration is not the official one. Thus official (56b) and illustrated (56c) coat of arms are provided for modeller's choice. In spite of limited information, this is one of the rare D-9 example with personal marking.

Focke Wulf Fw 190 Part 1

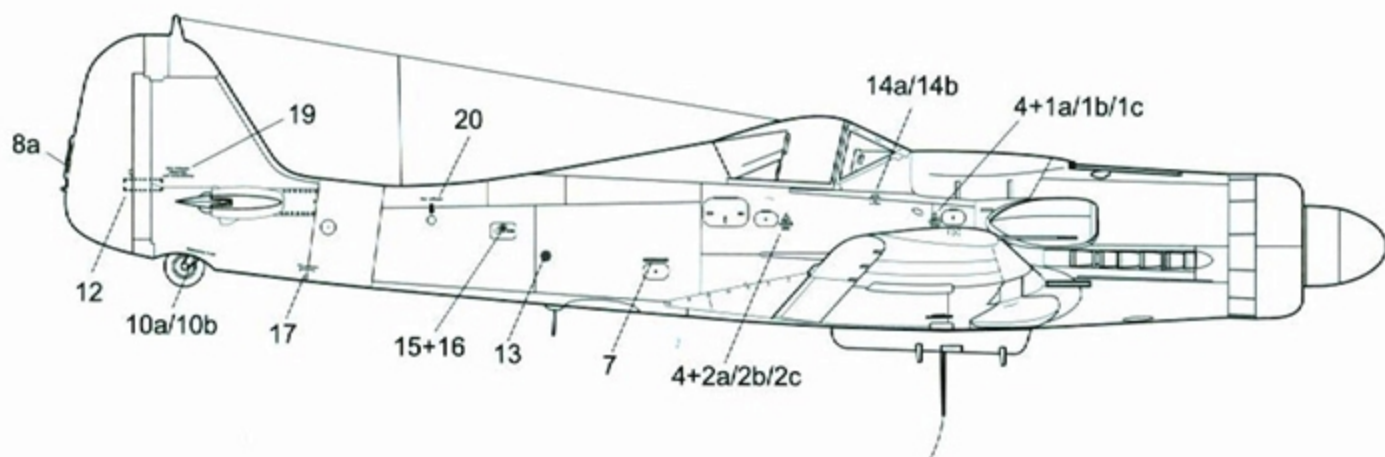
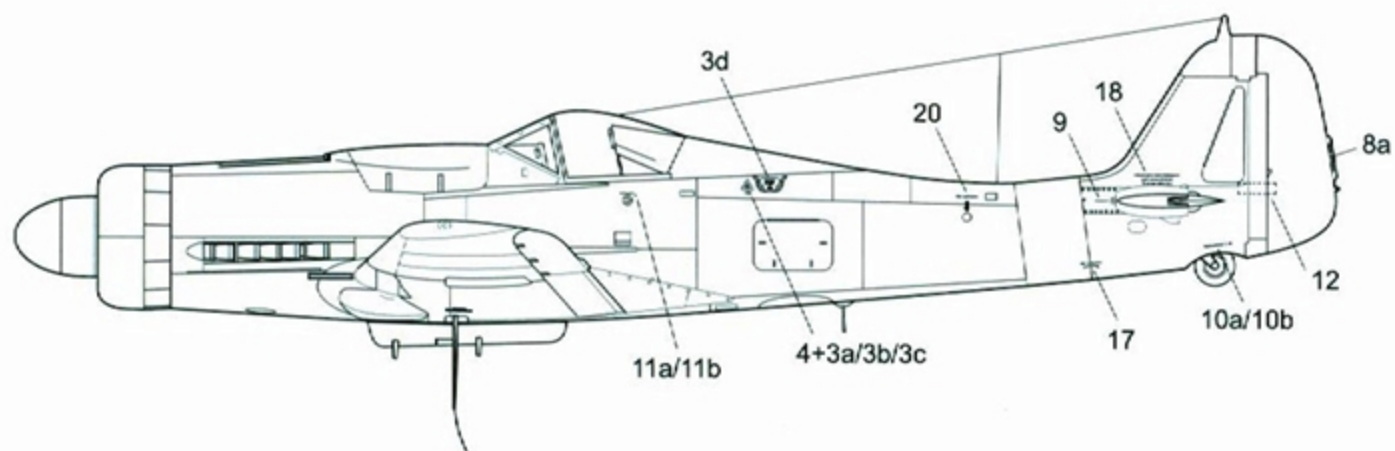
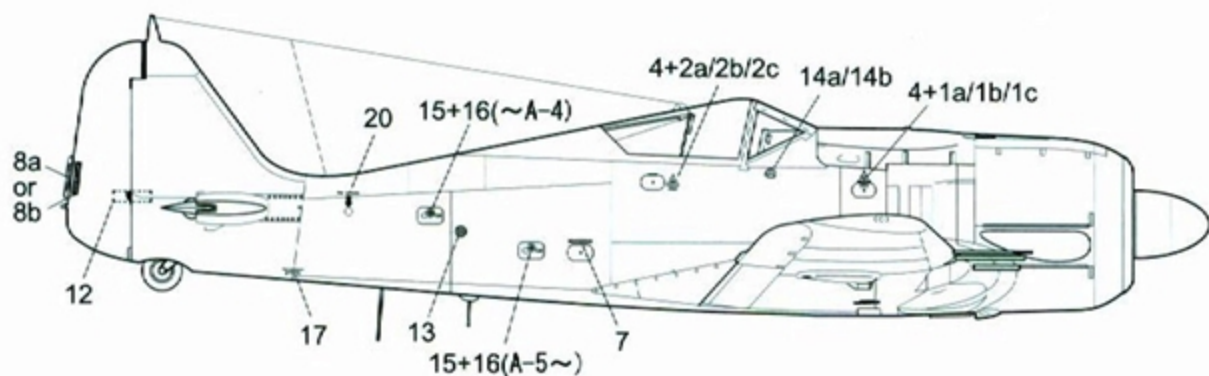
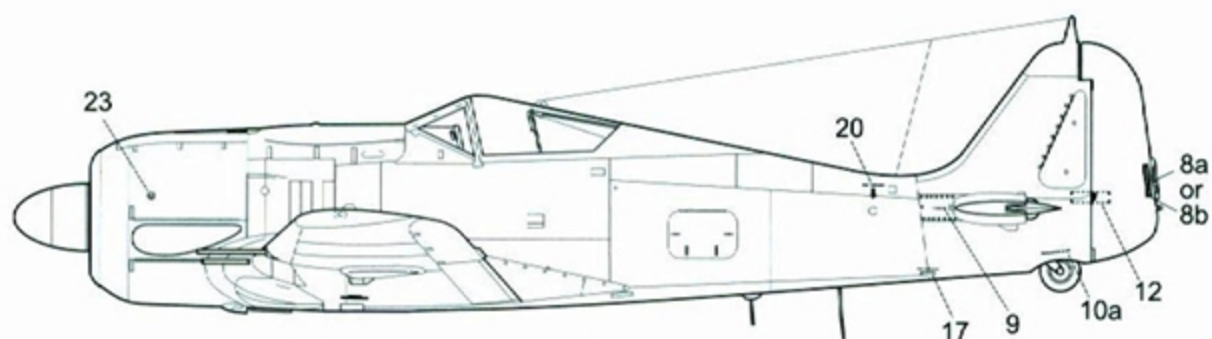

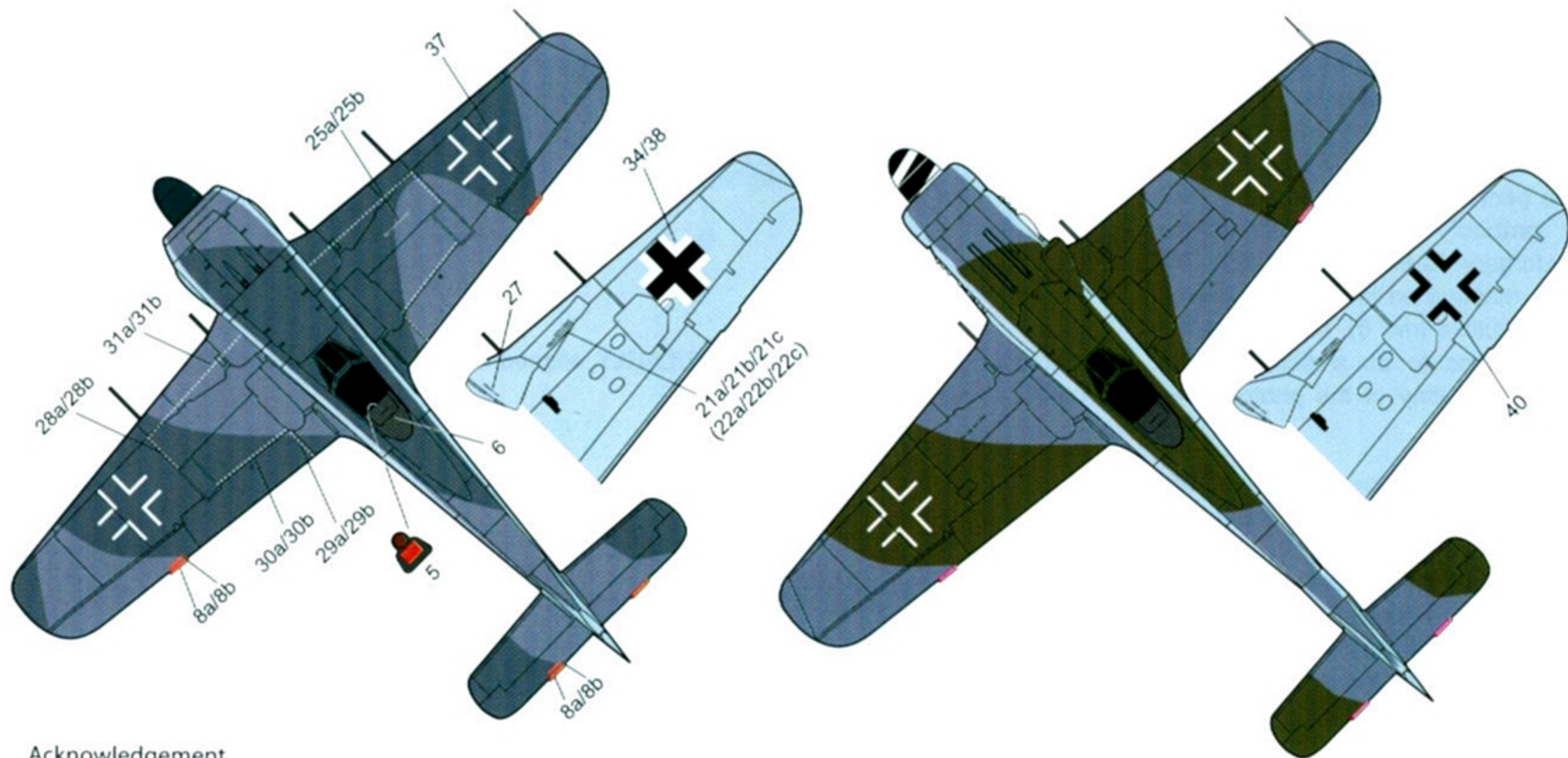

Acknowledgement

We thank Mr. Yuji Matsuki for his information and assistance.

Lifelike Decal is designed and produced in Japan with limited number of sheets for each titles. We aim to release items that have not been put on decals or for those there are no good decals. The items will cover military aircraft of various nations from WWI to modern jets. If you have suggestions for future subjects, we would like to hear from you. Please contact us at the following with your suggestions/information for future subjects.

Address; 2-8-7-202, Kameari, Katsushika, Tokyo 125-0061, Japan

Fax; +81-3-5680-6733, e-mail; lifelike@eos.ocn.ne.jp

お買い上げ頂き、有難うございます。本デカールに対するご意見、今後デカールとして出したら良い面白いマーキングの機体（第1次大戦～現用機）についての情報／提案がありましたら、お聞かせ下さい。

住所：125-0061 東京都葛飾区亀有2丁目8-7-202. fax: 03-5680-6733. e-mail: 上記)