

# Supermarine Seafang

## F.Mk 32

Plastic model

scale : 1/72

### History note

The first prototype definitive Mark 32 VB895 was first flown in June 1946. It was powered by a Griffon 89 engine rated at 2,350 hp (1,752 kW) driving two three-bladed contra-rotating propellers. In August 1946, VB895 was demonstrated to the Royal Netherlands Navy at Valkenburg. The same aircraft was flown by noted test pilot Mike Lithgow in May 1947, during deck landing trials on HMS Illustrious. Compared to the Seafire F.47, its performance advantage was not deemed to be enough to disrupt series production of new navalised Meteor and Vampire jet fighters. Also, the Seafang's low-speed handling characteristics were not as good as hoped, and the contemporary Hawker Sea Fury was preferred as a fleet fighter.

Seafang Mark 31 VG474 was used as a development aircraft for the Supermarine Attacker including the fitment of power-operated ailerons and contra-rotating propellers. The Attacker was a jet-powered development of the Spiteful/Seafang design which used the Spiteful laminar-flow wing and landing gear.

In 1943, as the design of the Spiteful was developing, Supermarine presented a brochure to the Air Ministry describing a "High-Performance Aeroplane for the Royal Navy", also known as the Supermarine 391. This design was intended to be used as a carrier-borne fighter, with a secondary role as a strike aircraft, able to carry an 18-inch (45.7 cm) Mark XV aerial torpedo. Bombs or rockets could also be carried and the fixed armament was four Hispano Mk. V 20mm cannon. The 391 used the Spiteful/Seafang wing and undercarriage mated to a wide centre-section incorporating leading edge air intakes feeding the coolant radiators for a 3,550 hp, 24 cylinder 46-H-24 (later known as the "Eagle"); this engine drove contra-rotating, four-bladed propellers. The fuselage was longer with a redesigned fin and rudder unit.[4]

Specifications for the 391 include a wingspan of 43 ft 6 in (13.3 m), a fuselage length of 39 ft 9 in (12.1 m) and a wing area of 335 ft<sup>2</sup> (31.2 m<sup>2</sup>). Maximum weights were 15,750 lb (7,144 kg) as a fighter and 17,250 lb (7,825 kg) when armed with a torpedo. The maximum speed was projected to be 546 mph (879 k/mh) at 25,000 ft (7,620 m).

### Plastic parts

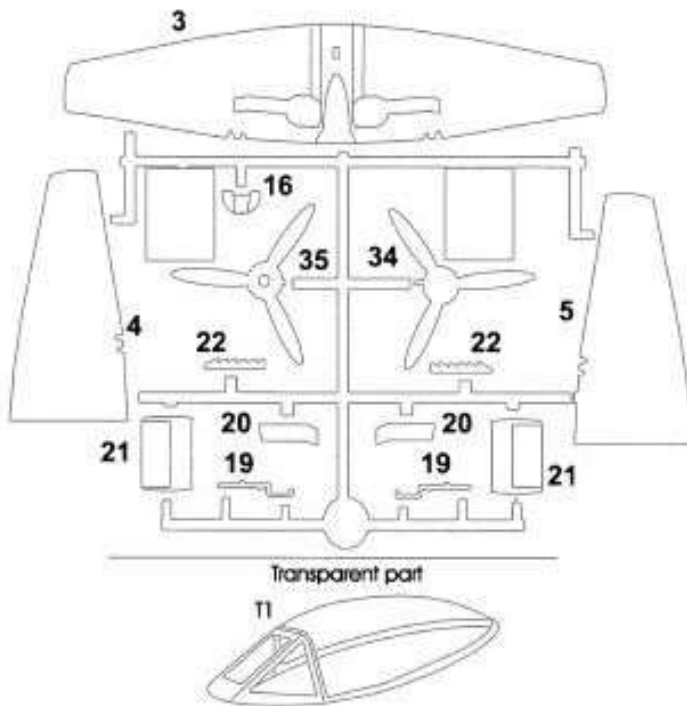
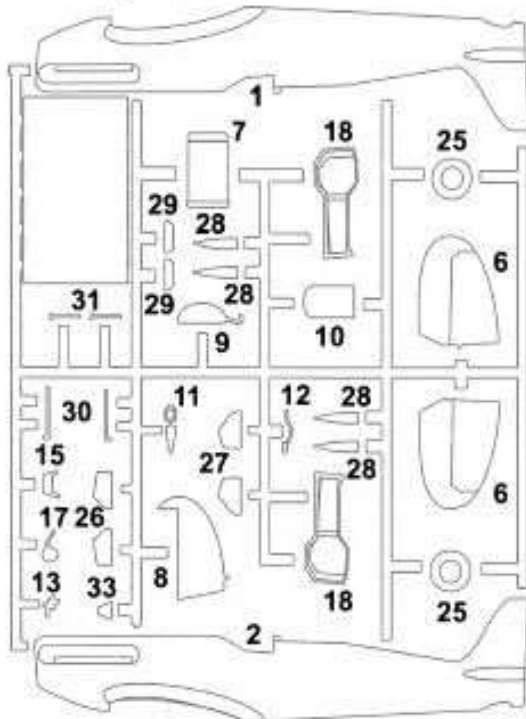

### Symbols



	Colour name	Humbrol		Colour name	Humbrol
A	Black	H33	H	Silver	H11
B	White	H34	I	Red Brown	H100
C	Interior Green	H76	J	Red	H132
D	Gunmetal	H53	K	Tyre	H85
E	Brown	H186	L	Rust	H113
F	Yellow	H24	M	Duck Egg Blue	H23
G	Aluminium	H56			

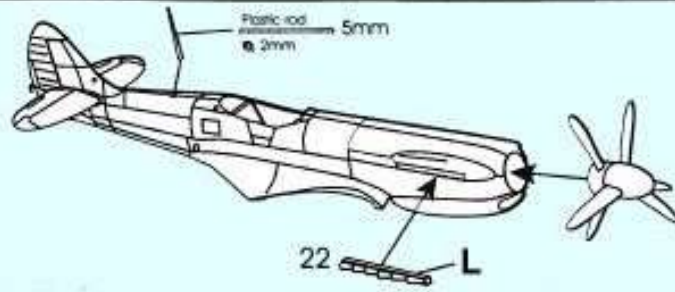
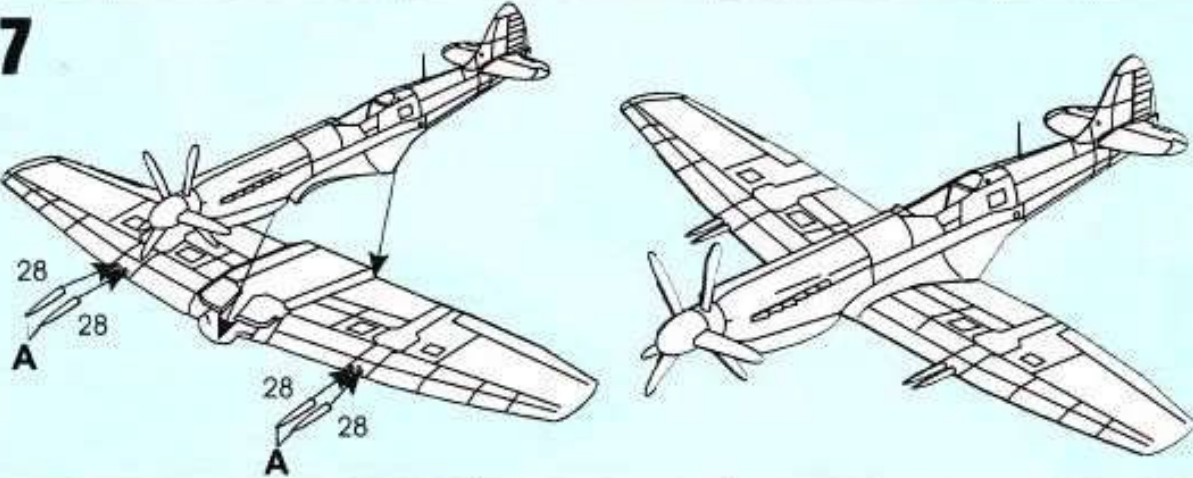
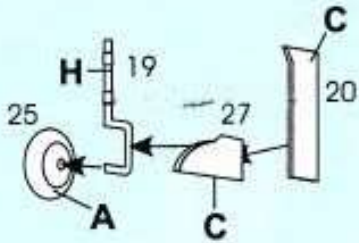
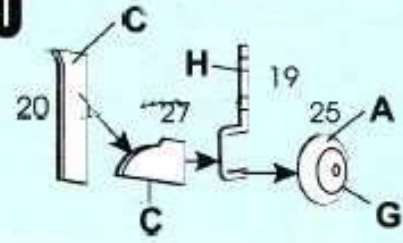
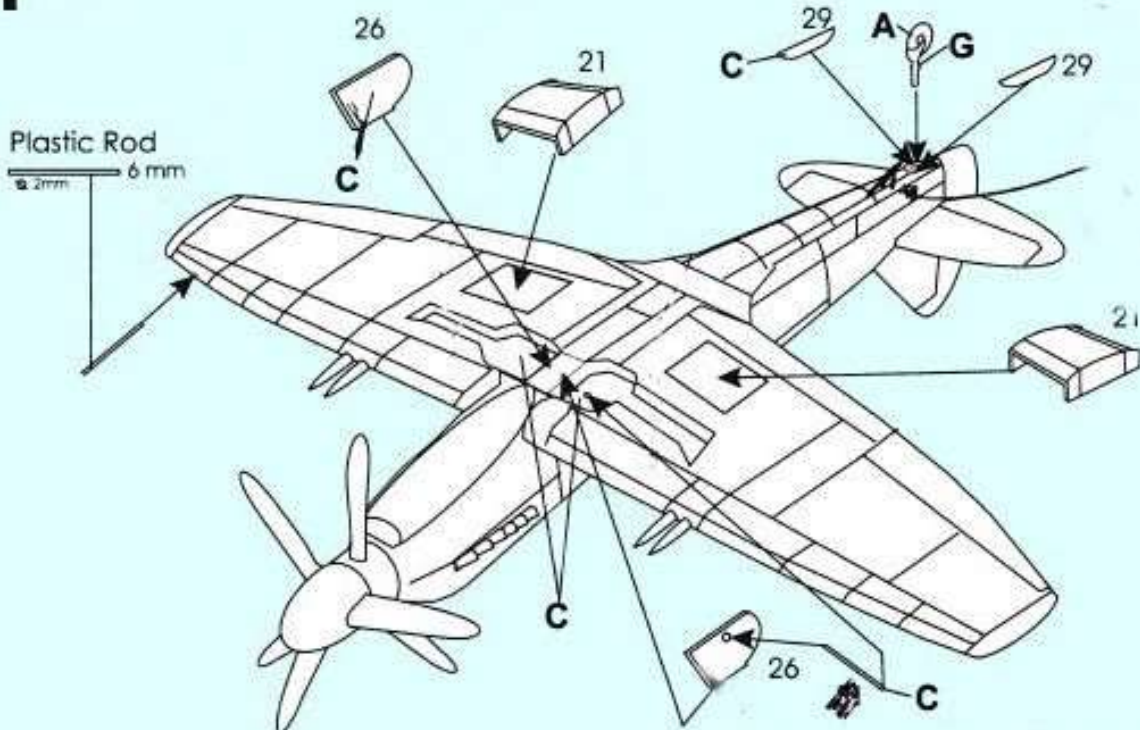

**6****7****8****9****10****11**

12

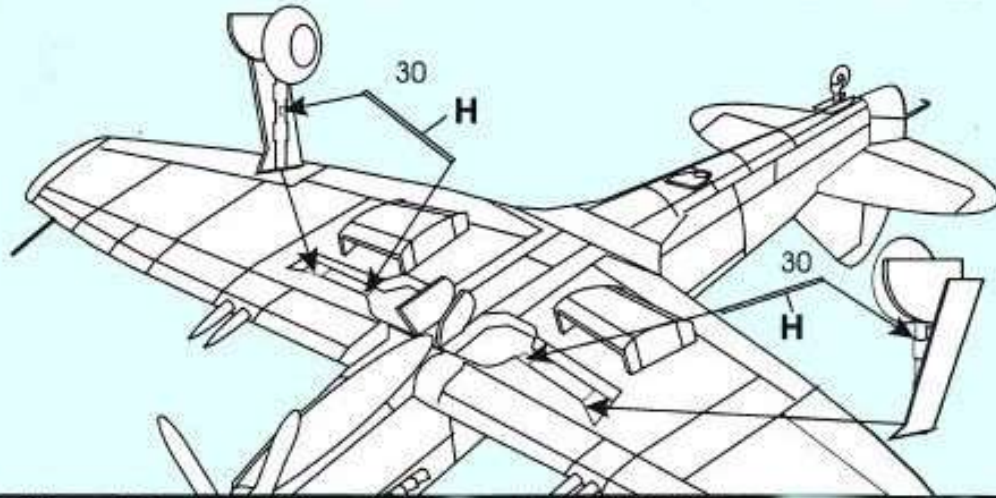

13

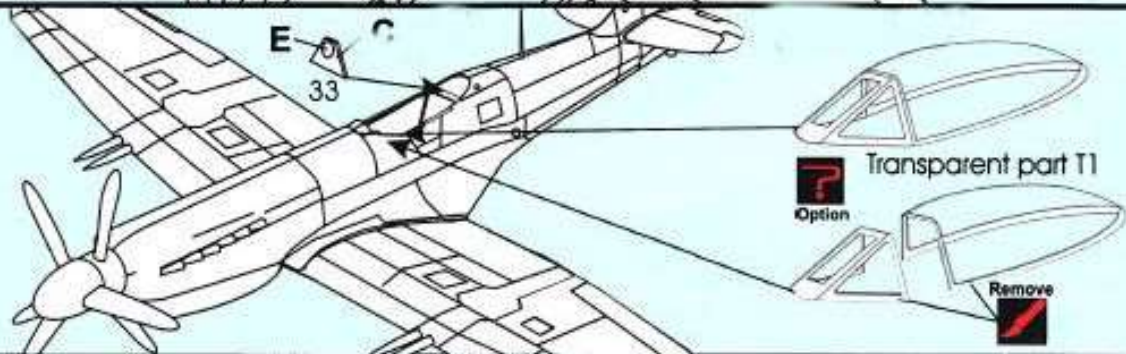

# Supermarine Seafang F.Mk 32

