

Zbarvení & Označení Colours & Markings

1 Miles M.2H, A-37-5, Australské letectvo , 1941
Miles M.2H, A-37-5, RAAF, 1941

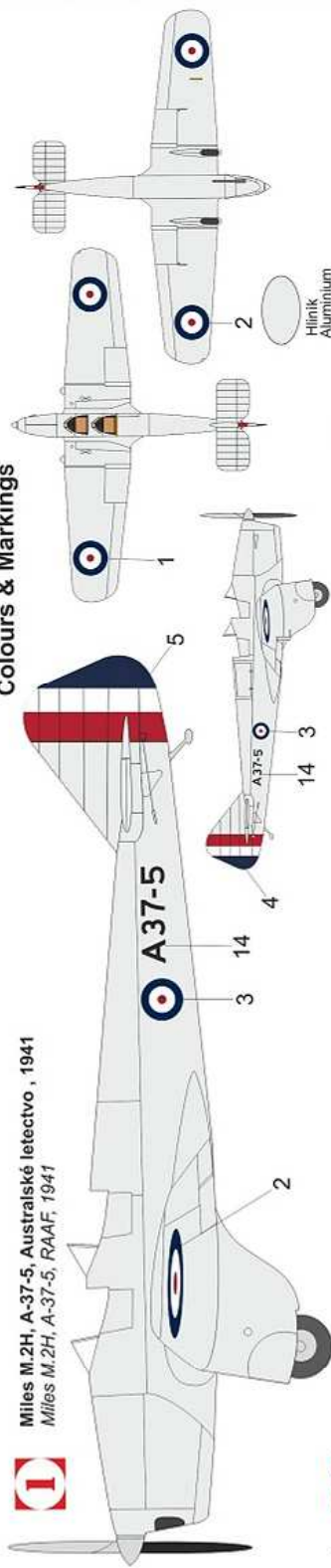

2 Miles M.2H, CF-AUV, letiště Markham, Ontario, Canada 1975.
Miles M.2H, CF-AUV, Markham airfield, Ontario, Canada 1975.

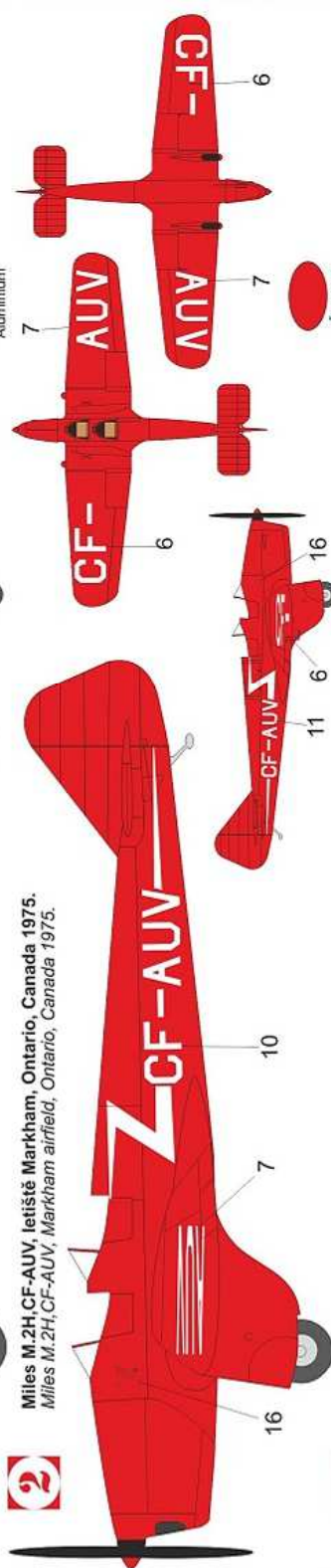

3 Miles M.2H, ZK-ADJ, „Spirit of Manawatu“, McRobertson Air Race, 1934.
Miles M.2H, ZK-ADJ, „Spirit of Manawatu“, McRobertson Air Race, 1934.

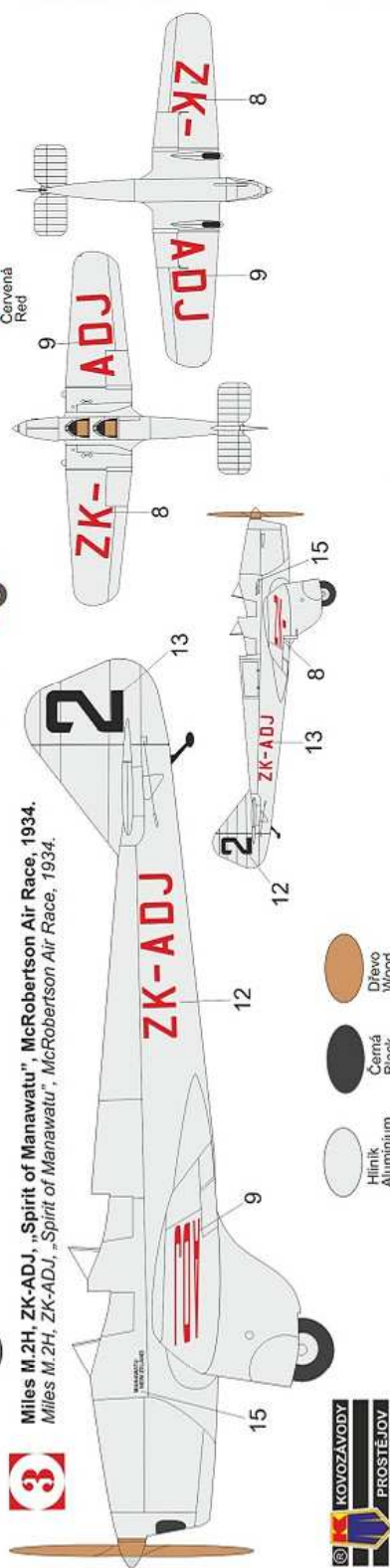

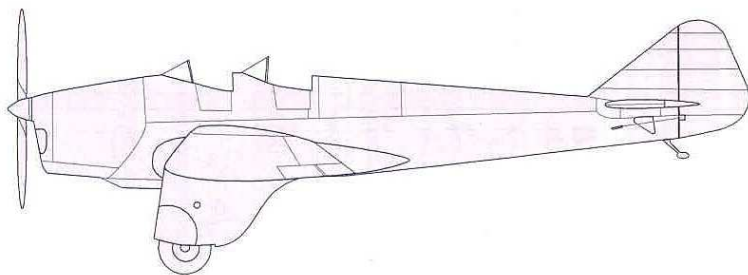

Miles M.2H

Hawk Major

Historie

Miles M.2 Hawk Major byl britský dvoumístný lehký jednoplošník z 30. let 20. století vyvinutý společností Miles Aircraft z letounu Miles Hawk. Hawk Major byla varianta Miles M.2 Hawk, vyvinutá F.G. Milesem, aby využila výhod nového motoru de Havilland Gipsy Major. Další změny zahrnovaly kovové (místo dřeva) uložení motoru a aerodynamický podvozek. Prototyp M.2F Hawk Major) poprvé vzletl v roce 1934. Vylepšená verze (M.2H) se vztlakovými klapkami nahradila M.2F na výrobní lince v roce 1935.

History

The Miles M.2 Hawk Major was a 1930s British two-seat light monoplane developed by Miles Aircraft from the Miles Hawk. The Hawk Major was a variant of the Miles M.2 Hawk, developed by F.G. Miles to take advantage of the new inverted de Havilland Gipsy Major engine. Other changes included metal (instead of wood) engine mounts and streamlined undercarriage. The prototype M.2F Hawk Major) was first flown in 1934. An improved version (the M.2H) with a trailing edge flap replaced the M.2F on the production line in 1935.



**VOLITELNÉ
OPTIONAL**



**VYVRTAT
DRILL HOLE**



**TMEL
PUTTY**



**ODSTRANIT
REMOVE**

Plastikové díly/Plastic parts

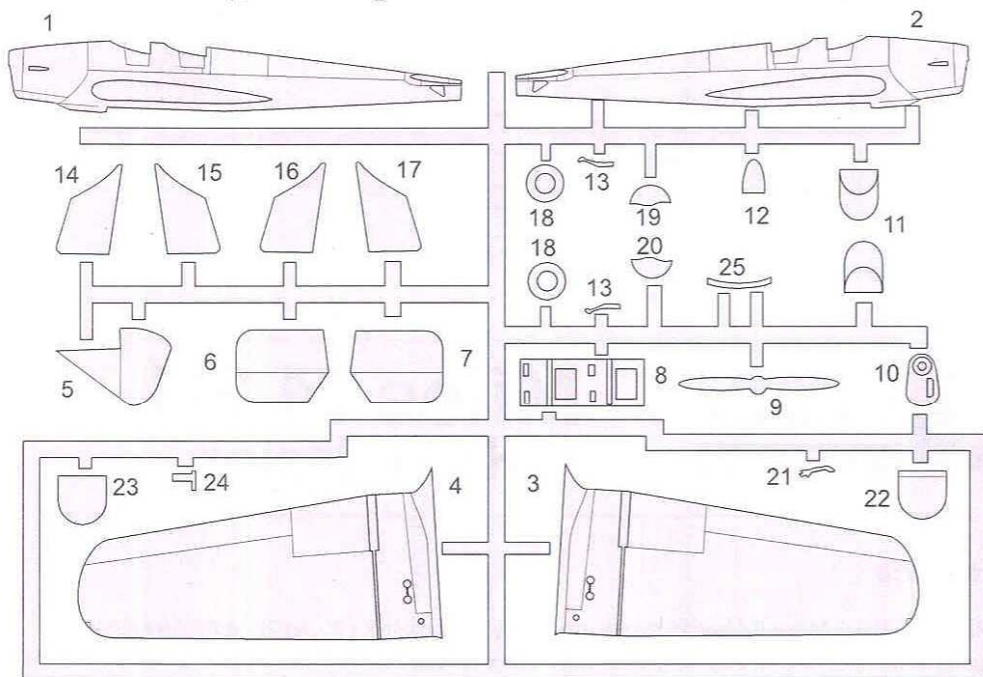

Průhledné díly/
Clear parts

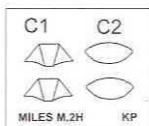

Stavební postup - Assembly instructions

1

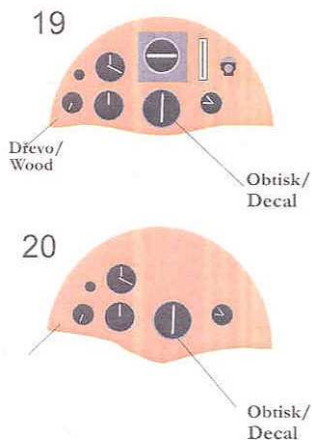

2

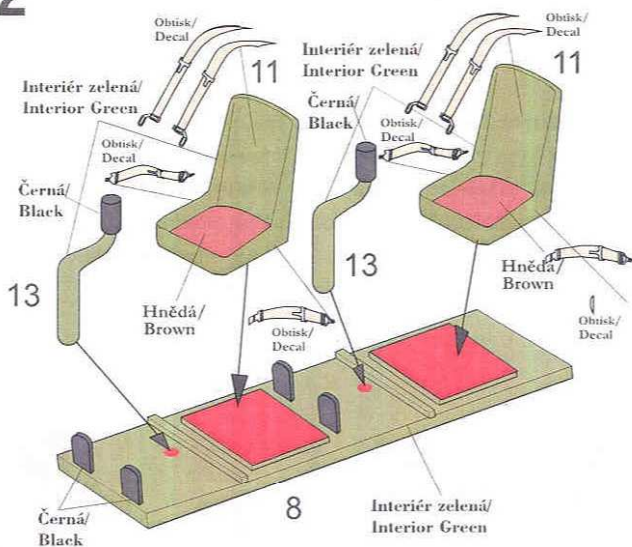

3

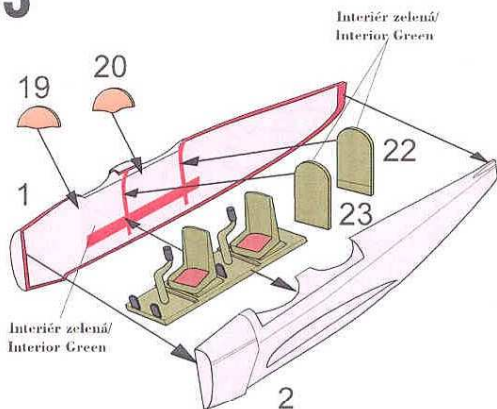

4

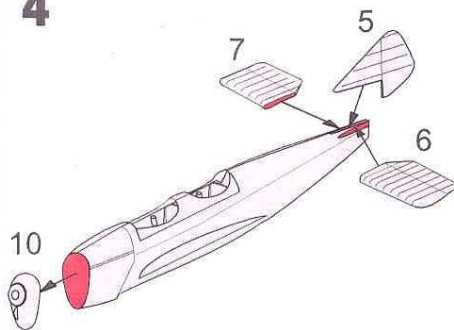

5

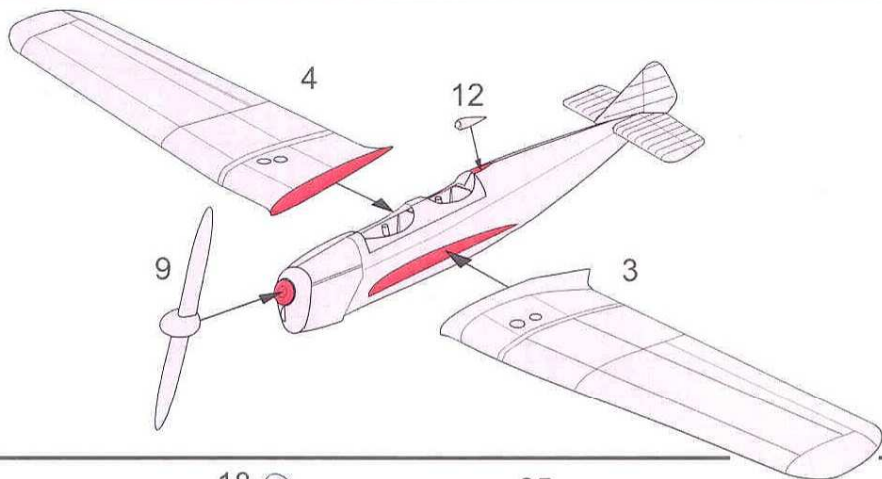

6

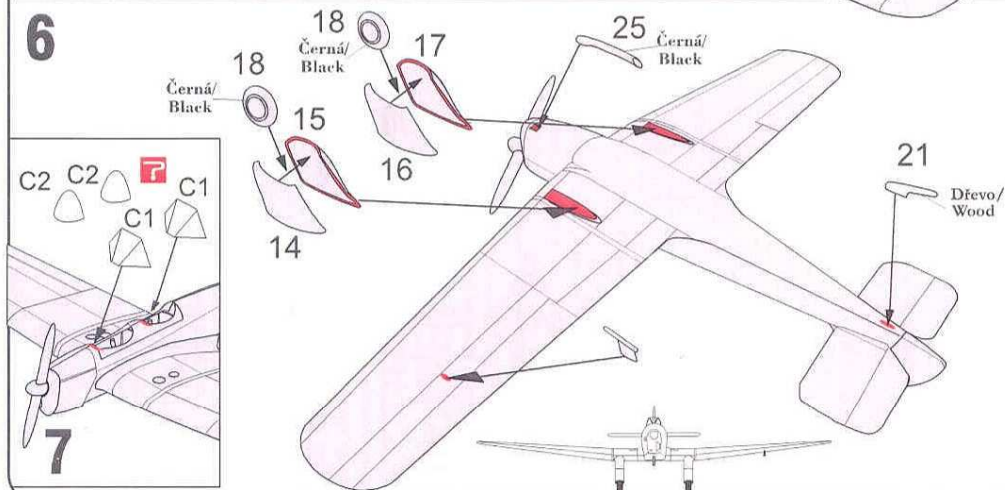

Miles M.2H Hawk Major

