

# Handley Page HAMPDEN

Plastic model scale : 1/72

### History note

The Handley Page HP.52 Hampden was a British twin-engine medium bomber of the Royal Air Force (RAF). It was one of a trio of then-large twin-engine bombers procured for the RAF, the other two being the Armstrong Whitworth Whitley and Vickers Wellington. The newest of the three medium bombers, the Hampden, was often referred to by aircrews as the "Flying Suitcase" because of its cramped crew conditions.

The Hampden served in the early stages of Second World War, bearing the brunt of the early bombing war over Europe, taking part in the first night raid on Berlin and the first 1,000-plane raid on Cologne. As the war went on, it became clear that the Hampden was unsuited to combat missions in the modern air war and, after a period of mainly operating at night, it was retired from RAF Bomber Command service in late 1942.

### Plastic parts

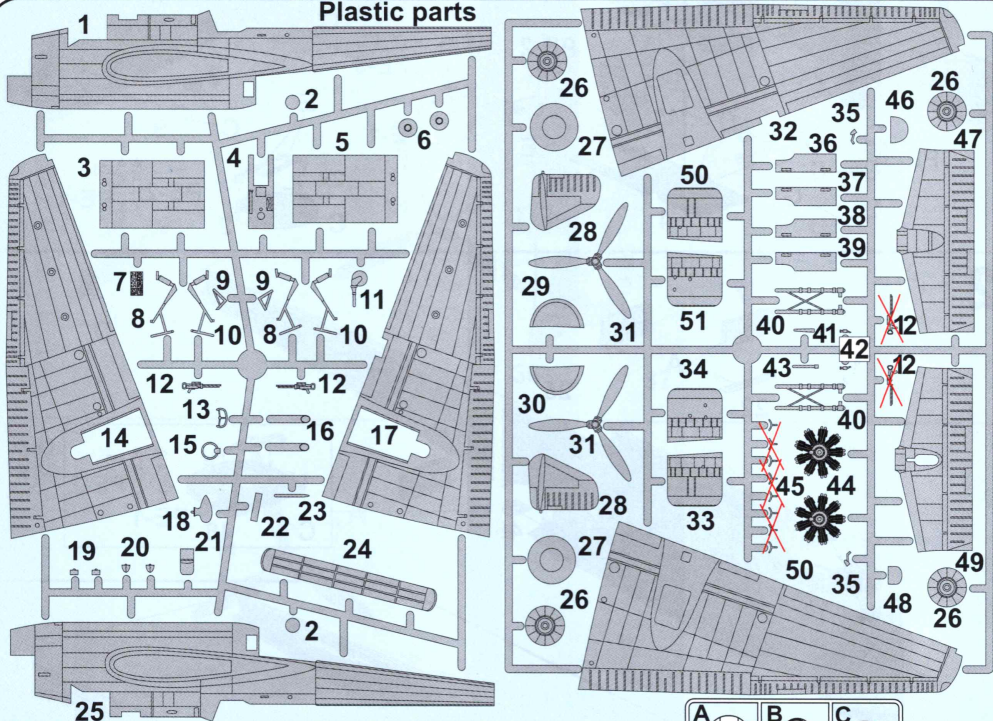

### Metal parts

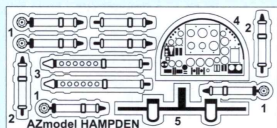

### Foil

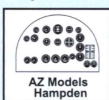

### Clear parts

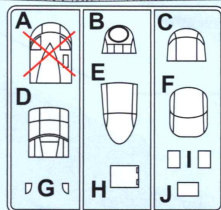

### Symbols



	Colour name	Humbrol	Colour name	Humbrol
<b>A</b>	<b>Black</b>	<b>H33</b>	<b>G</b> Aluminium	<b>H56</b>
<b>B</b>	<b>White</b>	<b>H34</b>	<b>H</b> Silver	<b>H11</b>
<b>C</b>	<b>Interior Green</b>	<b>H76</b>	<b>I</b> Red Brown	<b>H100</b>
<b>D</b>	<b>Gunmetal</b>	<b>H53</b>	<b>J</b> Red	<b>H132</b>
<b>E</b>	<b>Brown</b>	<b>H186</b>	<b>K</b> Tyre	<b>H85</b>
<b>F</b>	<b>Yellow</b>	<b>H24</b>	<b>L</b> Rust	<b>H113</b>

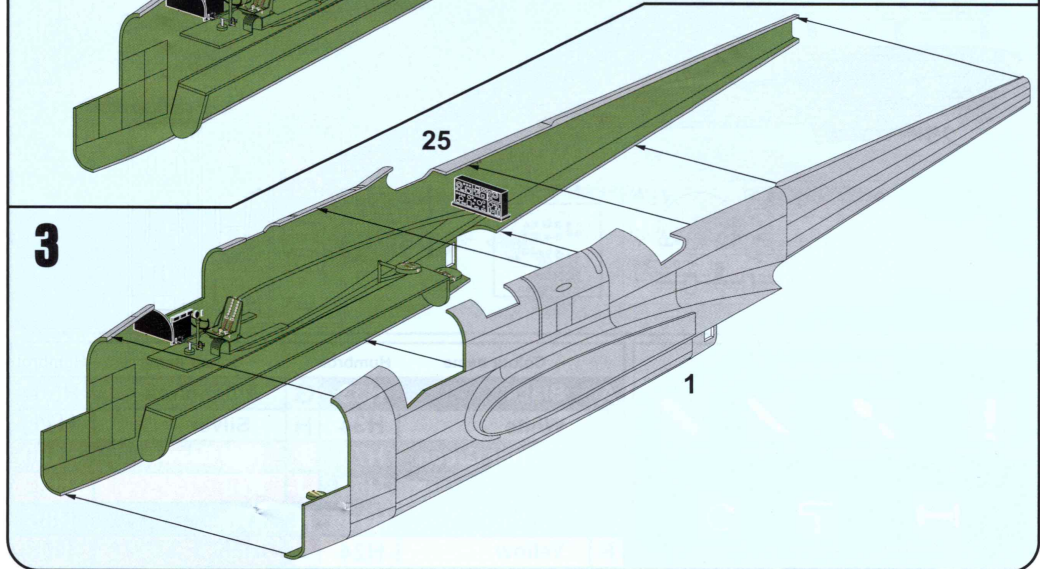
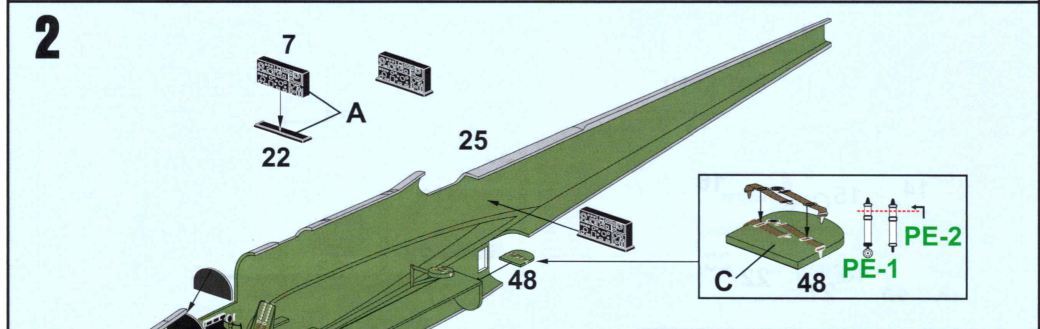
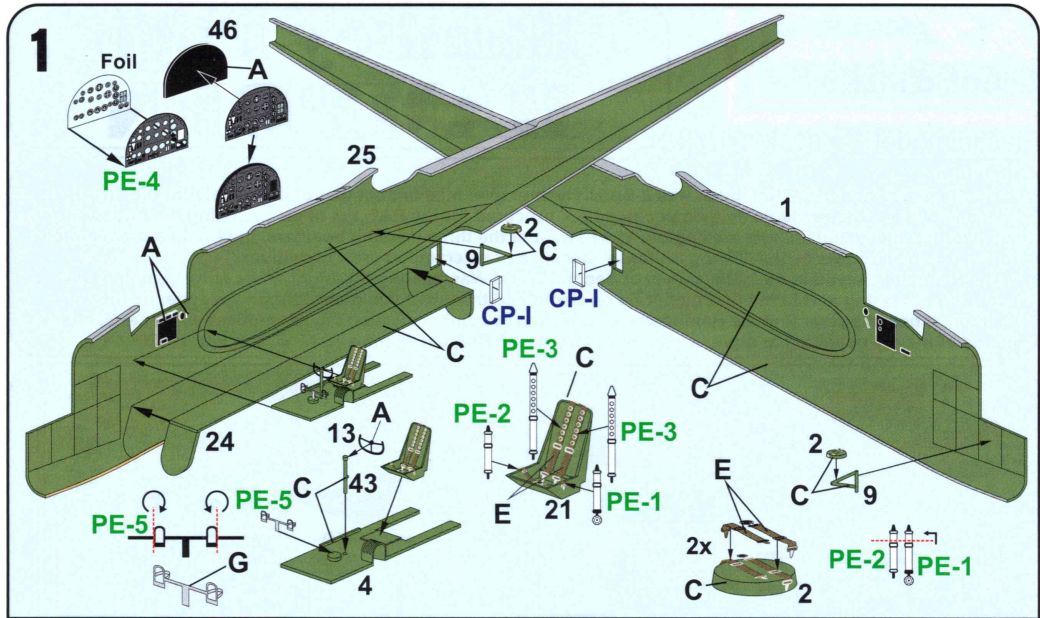

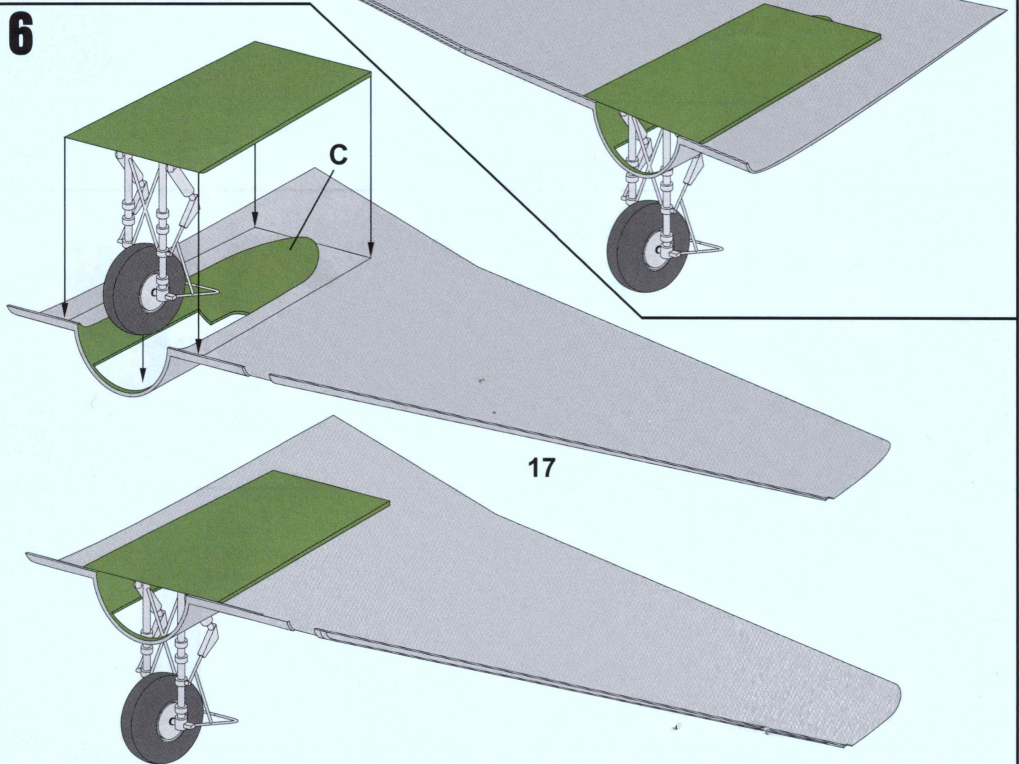
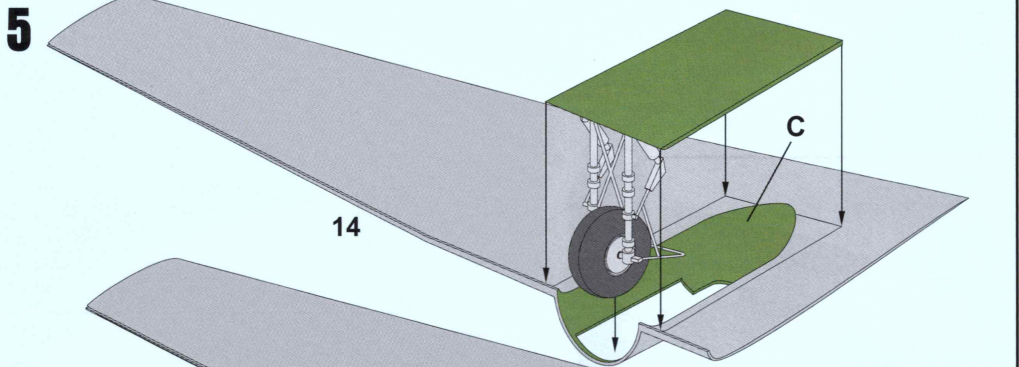
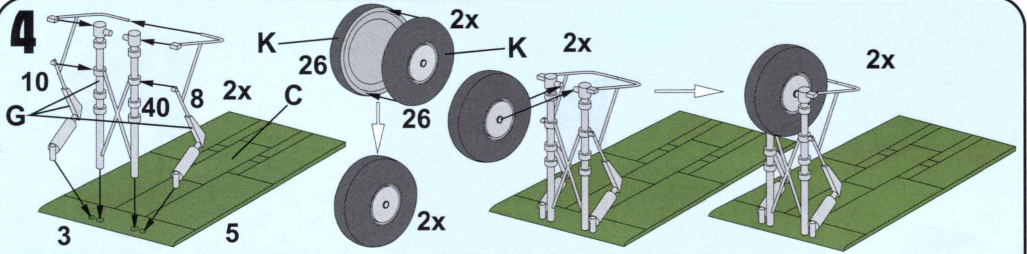

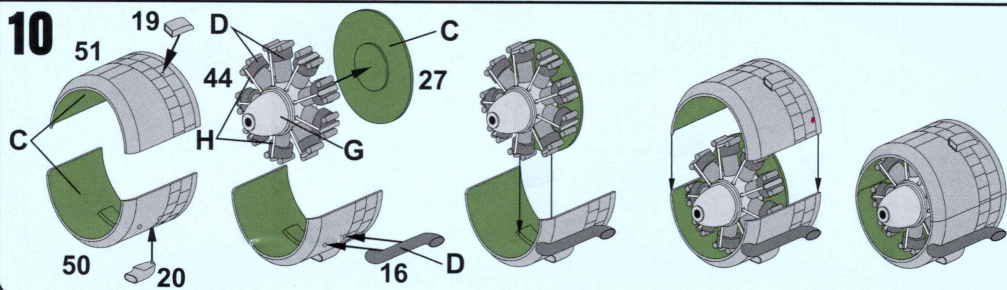
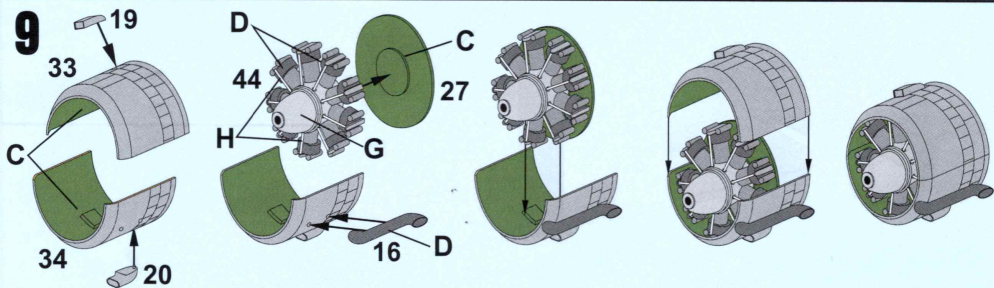
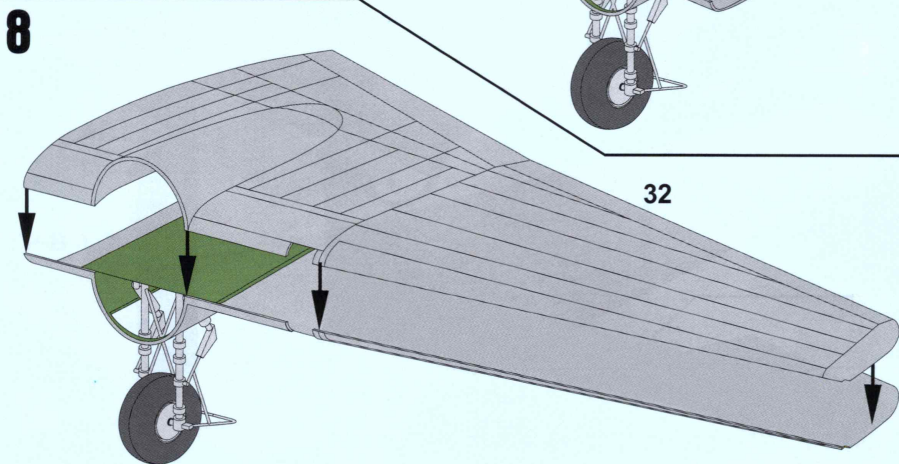
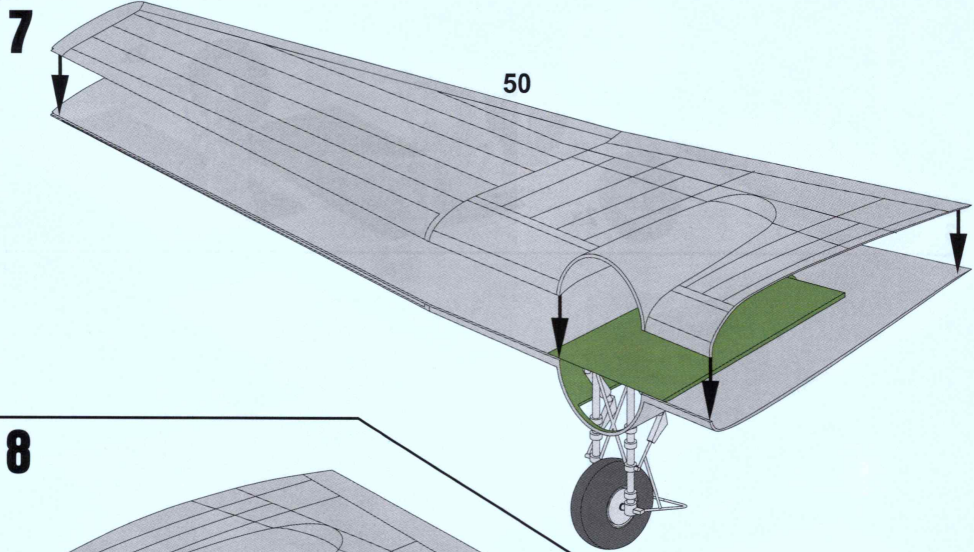

11

CP-G  
Clear red

35

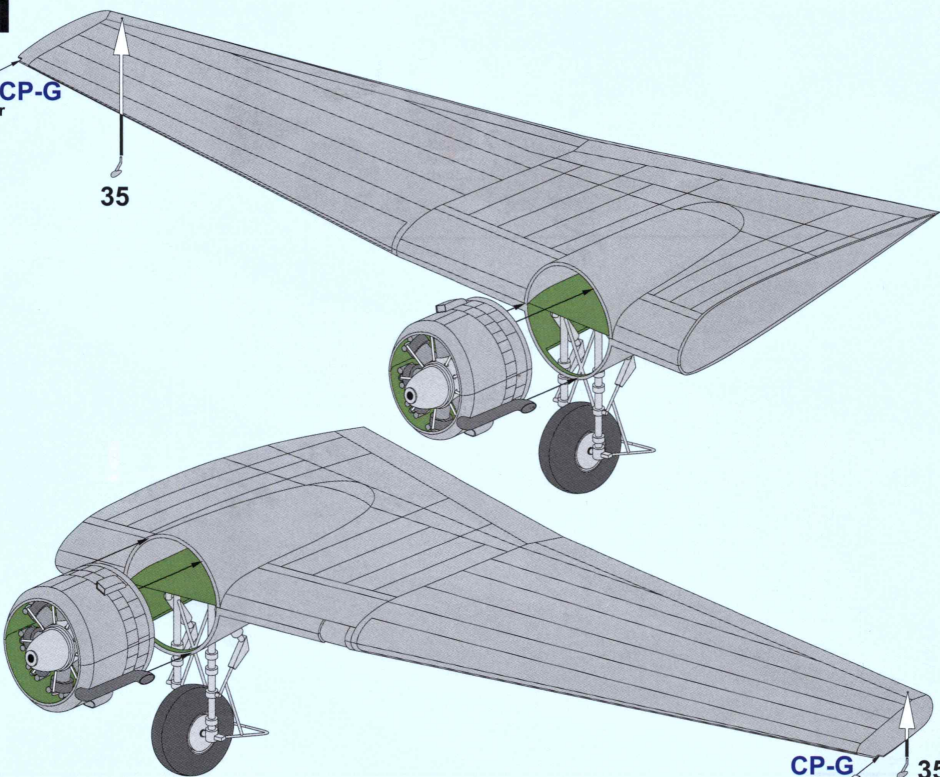

CP-G  
Clear green

35

12

49

Produce  
new



1,15mm

Open hole

11 K

47

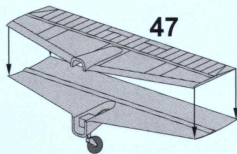
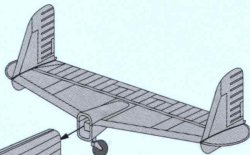

29 28

28

30

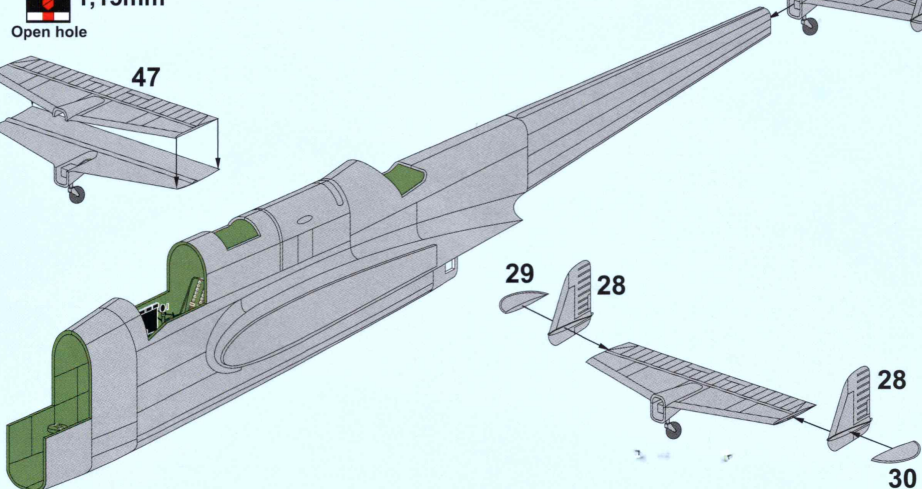

# 13

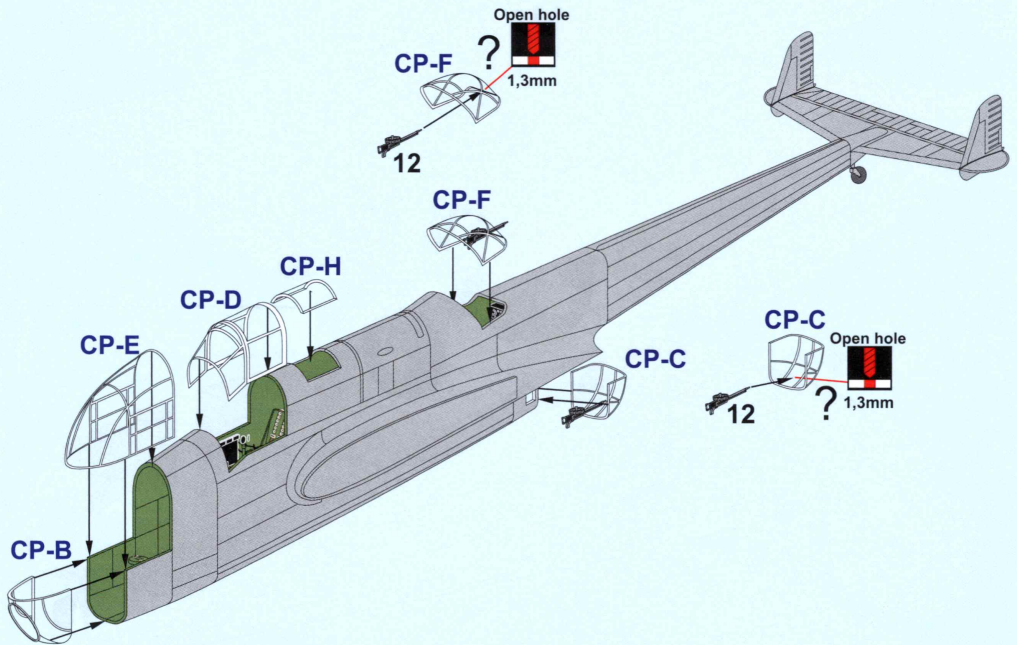

# 14

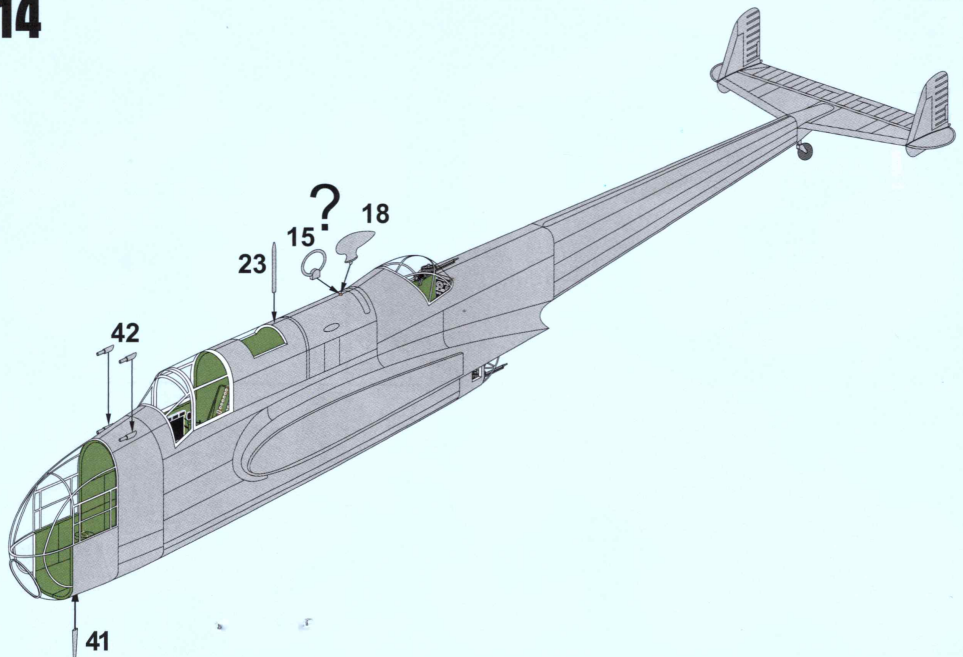

15

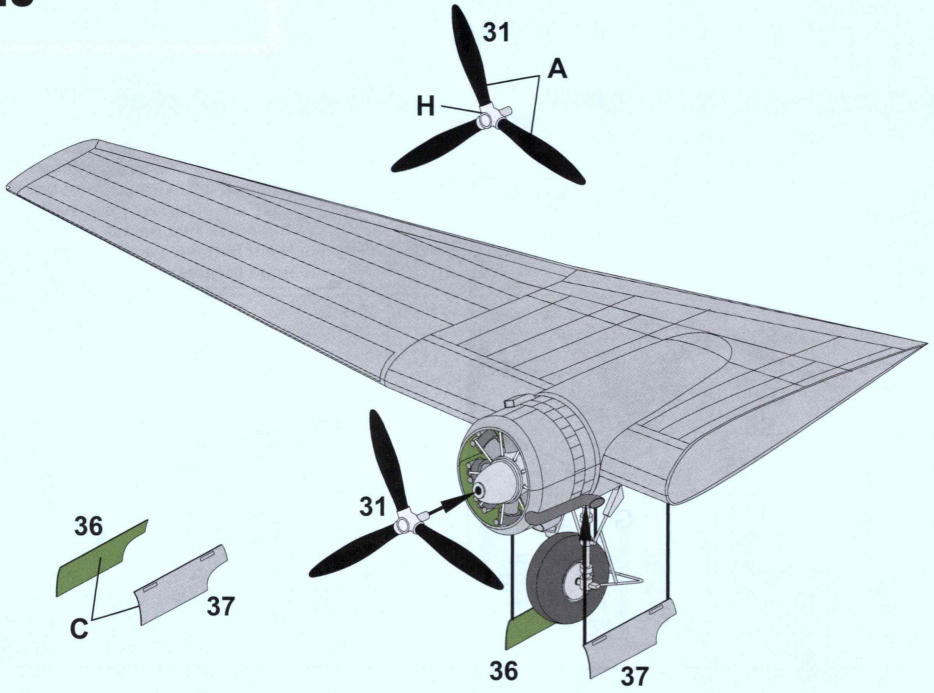

16

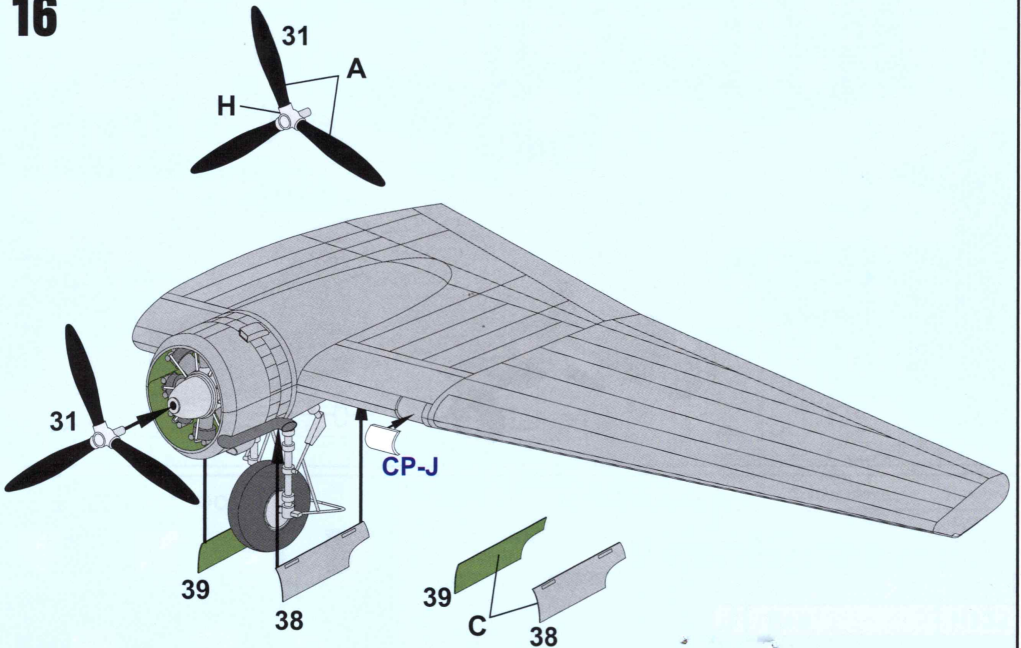

17

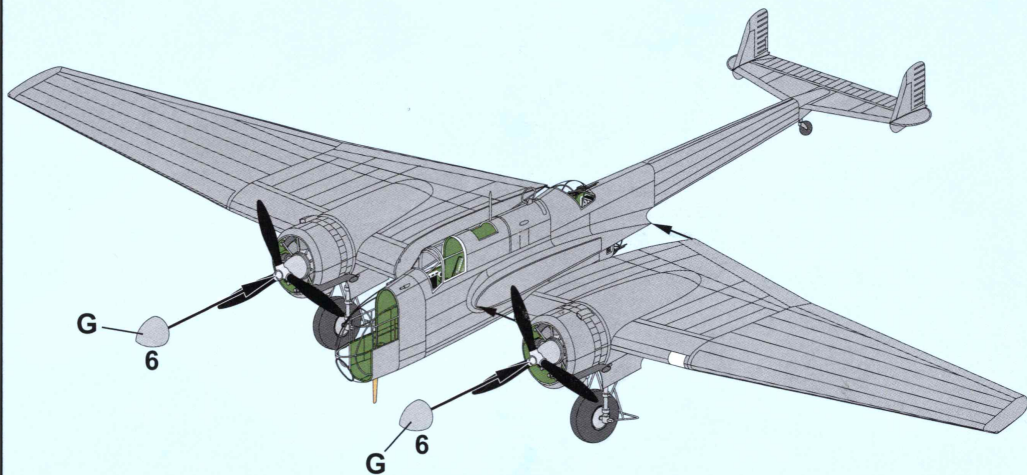

18

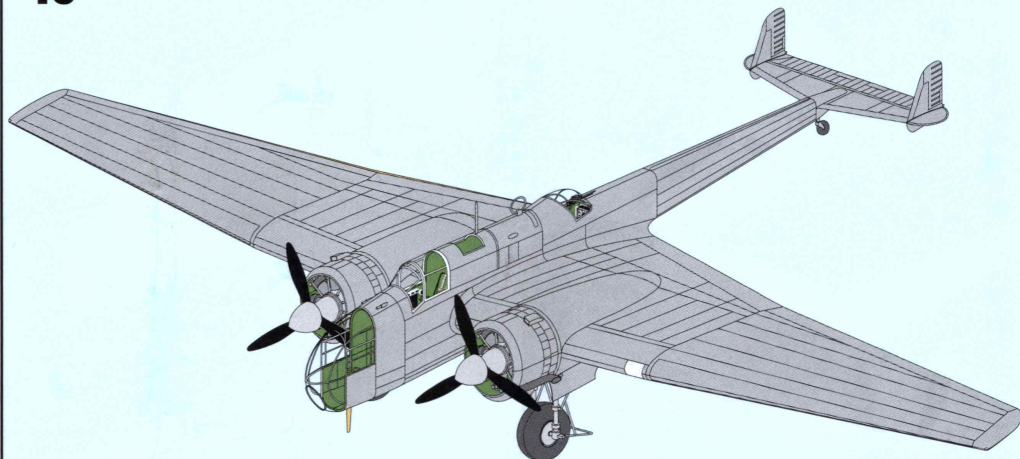



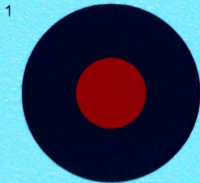
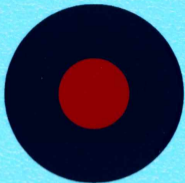

E A V E



AE224

AE224

AE360

AE360

Z Z P

C C P



AE238 AE238

EQ EQ



HANDLEY PAGE  
„HAMPDEN” Mk. I  
nosearts  
AZ model  
AZ 7548

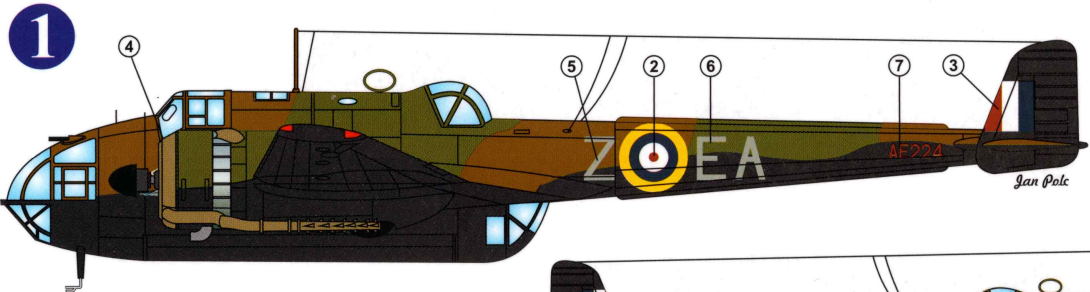

**1**  
Hampden Mk. I, EA-Z, AE 224, flown by S/Ldr D. B. Drakes, No. 49 Squadron, Scampton 1941

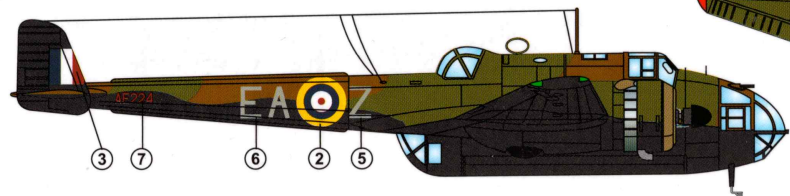

## Colours & Markings

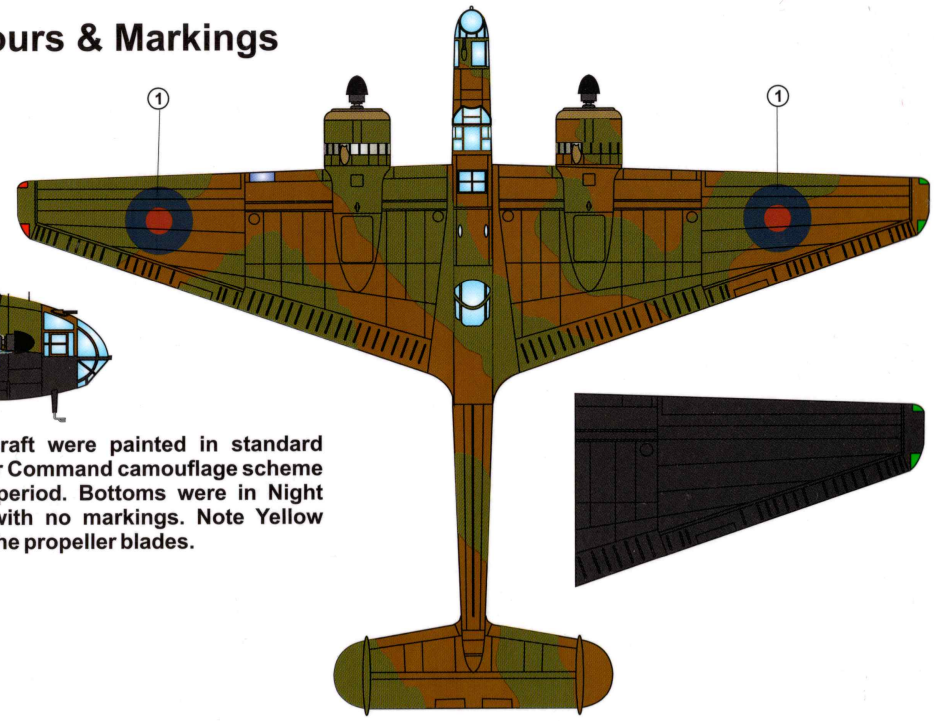

All aircraft were painted in standard Bomber Command camouflage scheme of the period. Bottoms were in Night Black with no markings. Note Yellow tips of the propeller blades.

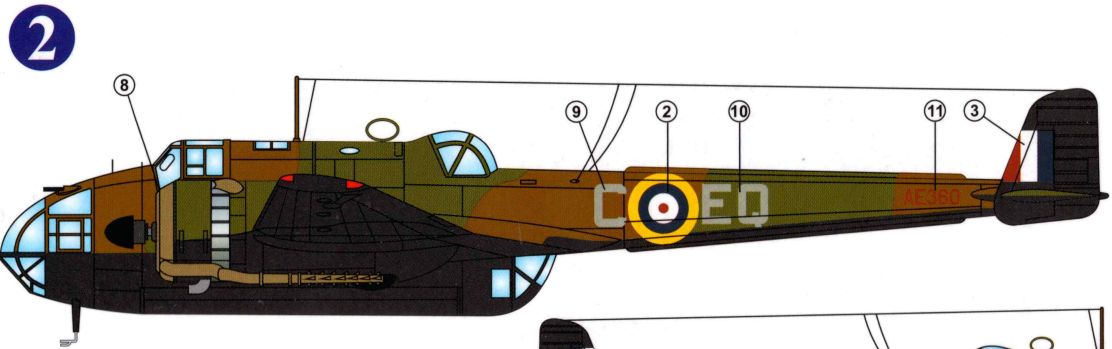

**2**  
Hampden Mk. I, EQ-C, AE 360, flown by S/Ldr W. J. Burnett, No. 408 Squadron, Syerston, summer 1941

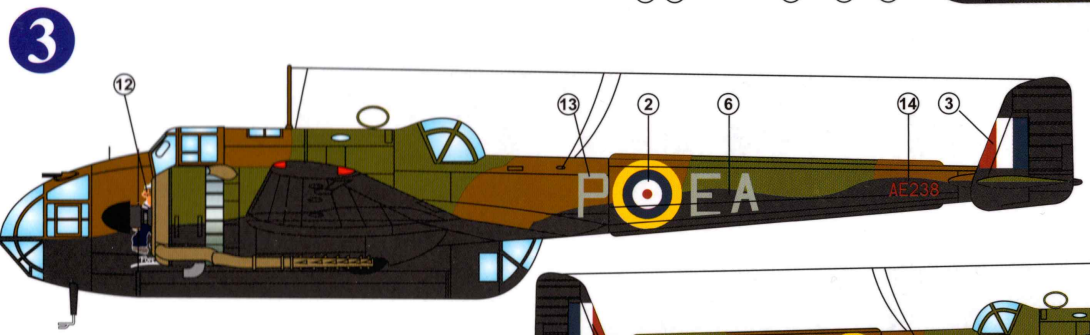
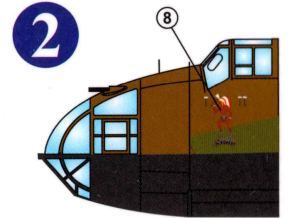
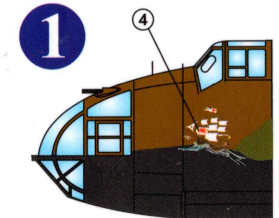
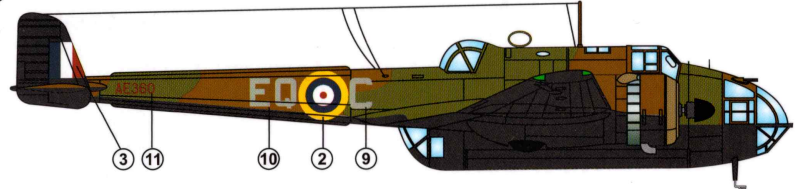

**3**  
Hampden Mk. I, EA-P, AE 238, No. 49 Squadron, Scampton, 1941

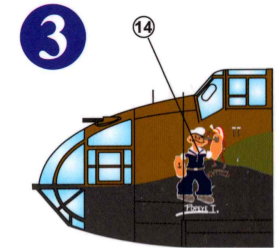
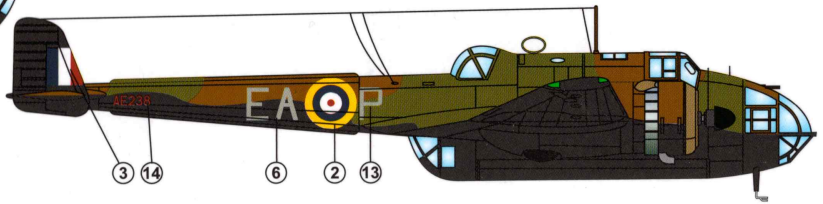

### NOSEART DETAILS

30	29	33
Dark Green	Dark Earth	Black
55	154	56
Bronze	Yellow	Aluminium

Paints used:  
**HUMBROL**