

# Gee Bee R6H Q.E.D.



## ASSEMBLY INSTRUCTIONS



The Gee Bee Q.E.D. ("Quod Erat Demonstrandum" - "it is proven" in Latin), aka Gee Bee R-6H, aka the "Conquistador del Cielo" (Sky Conqueror) was the last in a series of racing and touring aircraft from the Granville Brothers. Unlike the other famous Gee Bee aircraft, the Q.E.D had the distinction of never finishing a race it was entered in. The Gee Bee Q.E.D. was started by the Granville Brothers in 1933 prior to their October bankruptcy. On 11 February 1934, "Grannie Granville" died in Spartanburg, South Carolina delivering a Sportster E used to finance a new company based in New York and called Granville, Miller & De Lackner. The R-6H (Q.E.D.) was completed later in 1934 for customer Floyd B. Odium, with Jacqueline Cochran chosen as the pilot. The touring aircraft was designed with large fuel tanks to compete in the MacRobertson Air Race from RAF Mildenhall in East Anglia to Flemington Racecourse, Melbourne. A Curtiss Conqueror was the specified engine, but a Pratt & Whitney Hornet was substituted to make the race delivery date. The Gee Bee Q.E.D. shares the same general shape as the Gee Bee R1 racer, but is nearly 10 ft (3.0 m) larger in span and length. The aircraft was powered by a 675 hp (503 kW) Pratt & Whitney R-1690 Hornet. The fuselage is steel tube with fabric covering. The wings used wooden spars and ribs with mahogany plywood covering. The aircraft was painted bright green with orange markings to match the sponsor "Lucky Strike" cigarettes.

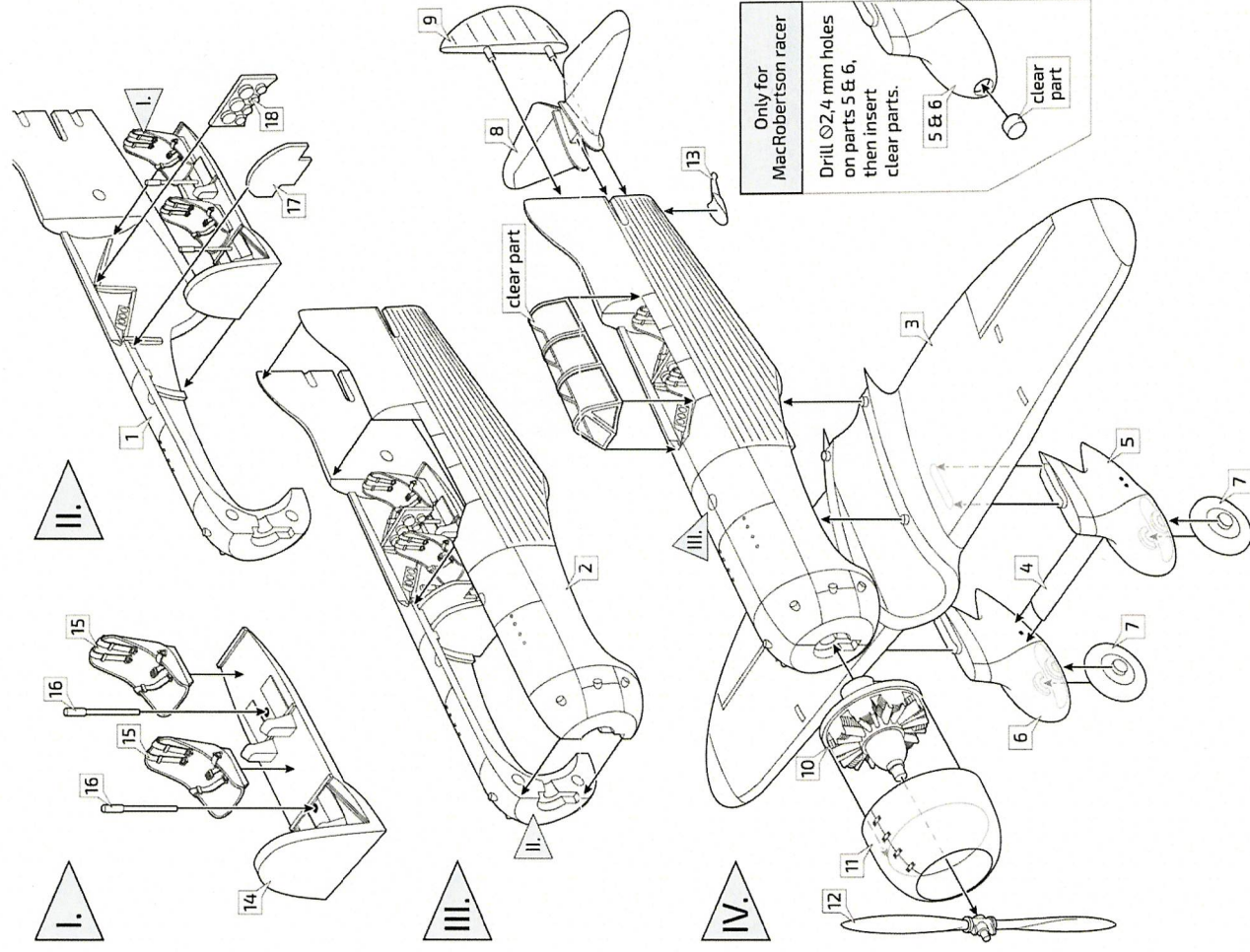

1. 1935 Bendix Race (no race number) - pilot Royal Leonard

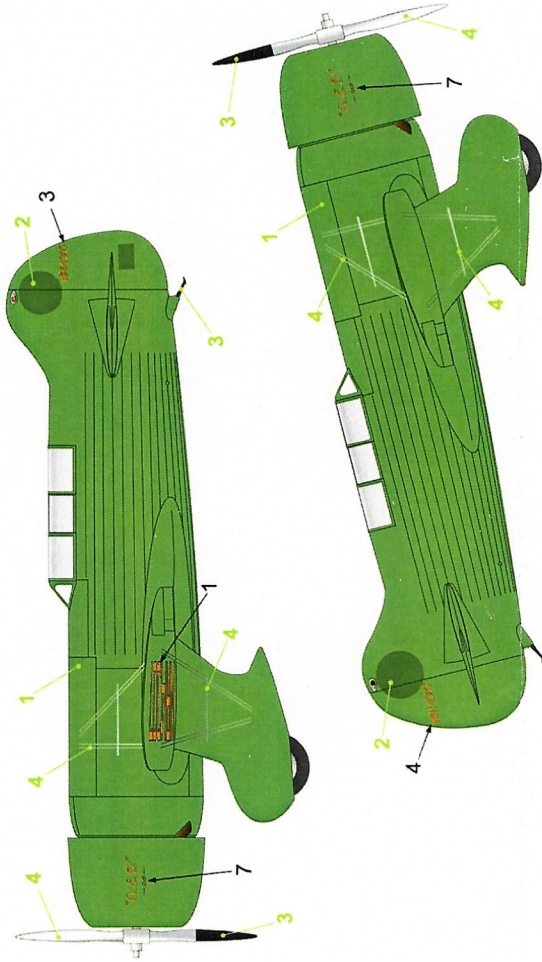

2. 1934 Bendix Race (race nr. 77) - pilot Lee Gehlbach

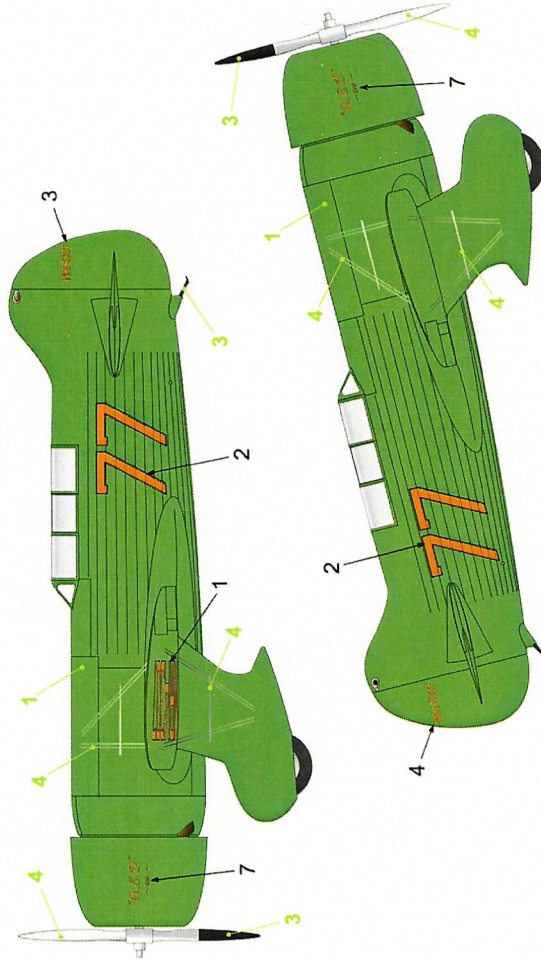

3. 1934 MacRobertson Air Race (race nr. 46) - Jacqueline Cochran & Wesley Smith

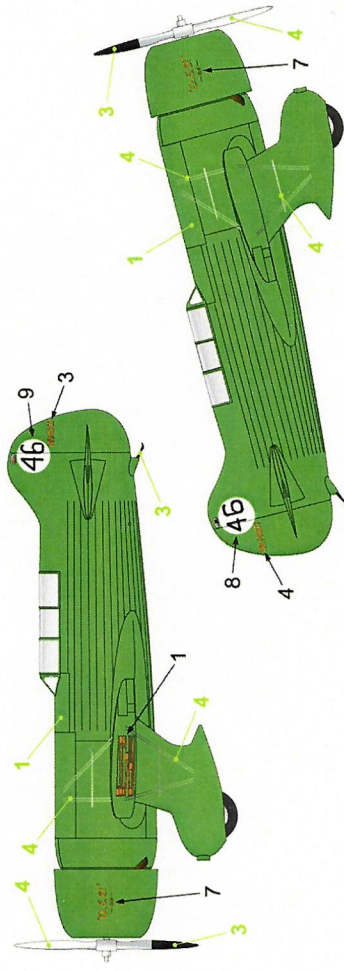

4. 1936 Thompson Trophy race (race nr. 90) - pilot Lee Miles

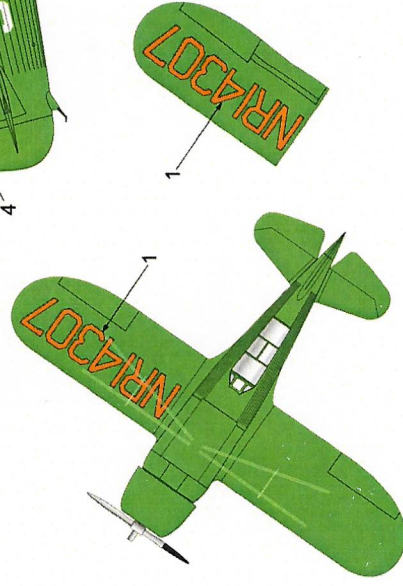
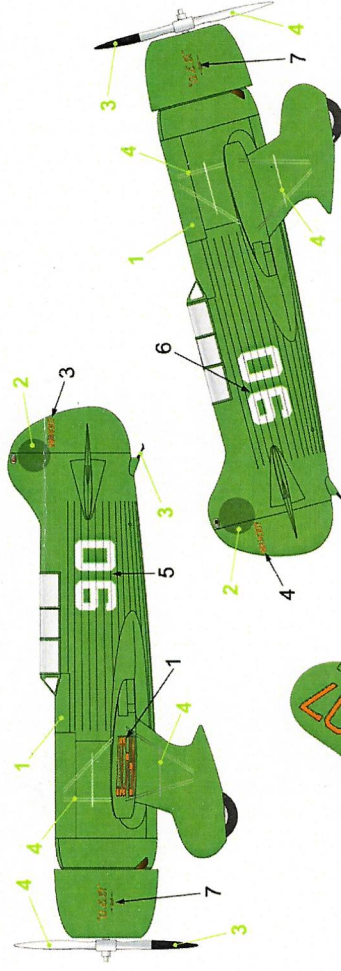

-  Lucky Strike Green 1.
-  Over-painted Green 2.
-  Black 3.
-  Bare metal 4.