

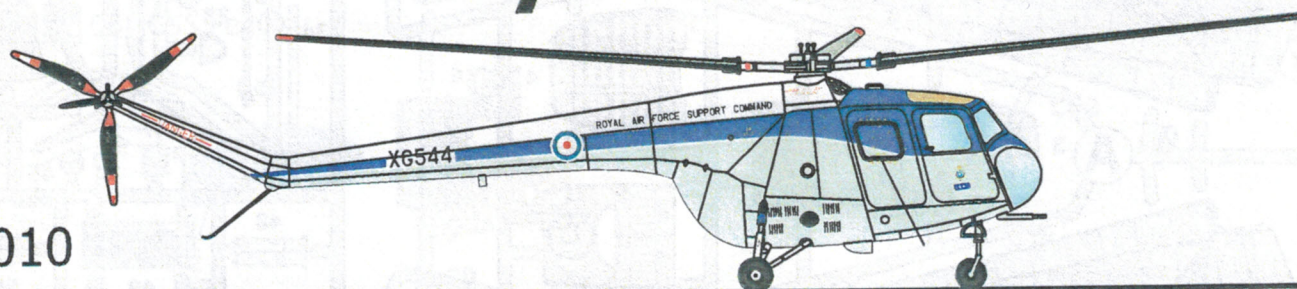

1/48 SCALE MODEL CONSTRUCTION KIT

Sycamore Mk.52

48010



Вертоліт Bristol Type 171 Sycamore був розроблений та побудований вертолітним підрозділом компанії Bristol Airplane Company. Він мав честь бути першим британський вертольотом, щоб отримав сертифікат льотної придатності, а також як першим британським спроектованим вертольотом що був введений у склад та служив у ВПС.

Як правило, він здатний взяти до трьох пасажирів, цей тип часто використовувався як транспортний.

Окрім британської військової служби, різні моделі Sycamore були виготовлені та експлуатувалися багатьма користувачами, включаючи військові операції за кордоном та цивільні замовники.

У 1959 році виробництво закінчилося після побудови 180-ти вертольотів.

The Bristol Type 171 Sycamore was an early helicopter developed and built by the helicopter division of the Bristol Aeroplane Company. It has the distinction of being the first British helicopter to receive a certificate of airworthiness, as well as being the first British-designed helicopter to be introduced by and to serve with the Royal Air Force.

Typically capable of seating up to three passengers, the type was often used as a transport for both passengers and cargo alike.

In addition to its British military service, various models of the Sycamore were produced and operated by a number of users, including overseas military operations and civil customers. Civilian operations typically involved transportation, mountain rescue, and aerial survey work. In 1959, production of the Sycamore ended after 180 rotorcraft had been completed.

Технічні характеристики / Technical specifications:

Довжина/Length - 18.62 м; Діаметр ротора/Rotor diameter - 14,8 м; Висота/Height - 4,23 м; Злітна вага (макс.)/Loaded weight - 5600 kg; Дальність польоту/Range - 238 км; Крейсерська швидкість/Cruising speed - 127 км/ч; Кількість пасажирів/Number of passengers - 3.

СПЕЦІАЛЬНІ СИМВОЛИ/USED SYMBOLS



CEMENT
КЛЕЯТИ



DON'T CEMENT
НЕ КЛЕЯТИ



REMOVE
ВІДРІЗАТИ



SYMMETRICAL
СИМЕТРИЧНО



MULTIPLE
КРАТНО



BEND
ЗГНУТИ



OPEN WHOLE
СВЕРДЛИТИ



VARIANTS
ВАРІАНТИ



TO PAINT
ФАРБУВАТИ

КОЛЬОРИ ФАРБ/USED PAINTS



White
Humbrol 34



Black
Humbrol 85



Matt Black
Humbrol 33



Red
Humbrol 60



Aluminium
Humbrol 56



Light Grey
Humbrol 64



Dark Sea Blue
Humbrol 104



Yellow
Humbrol 24



Brown
Humbrol 22



Green
Humbrol 120

PARTS OF THE MODEL

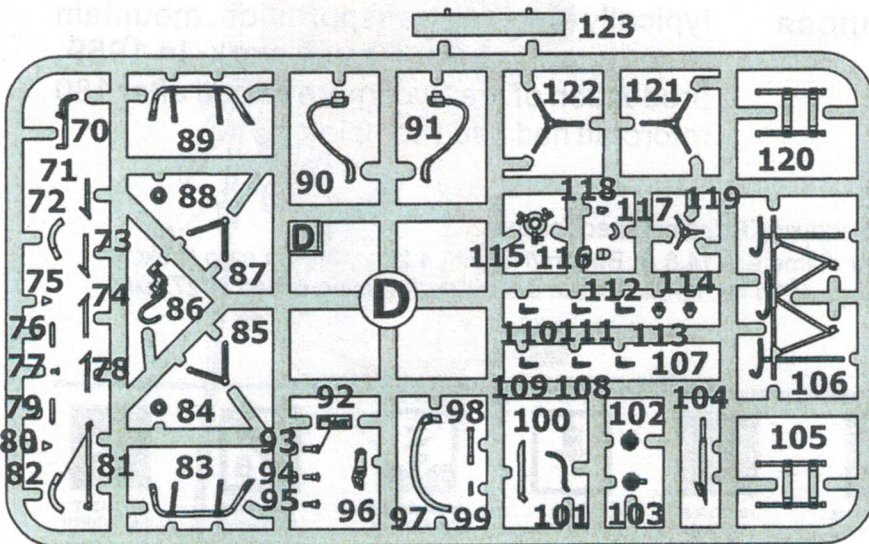
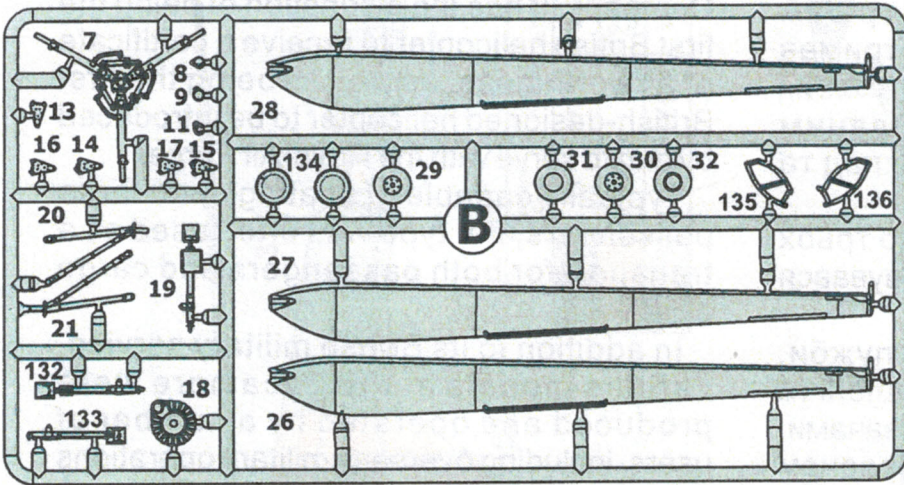
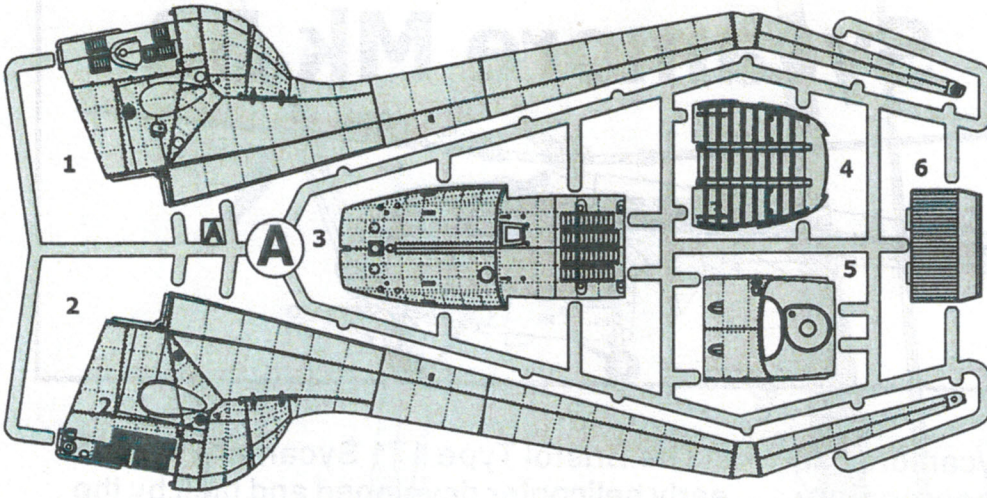

PE

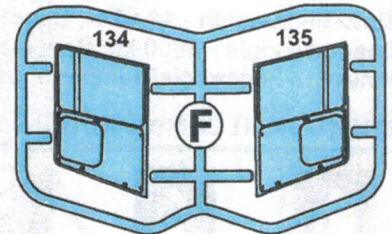
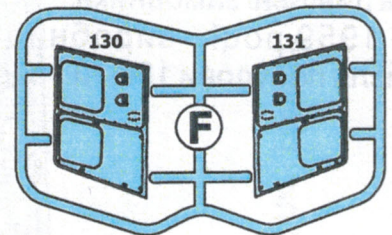
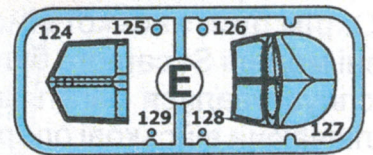
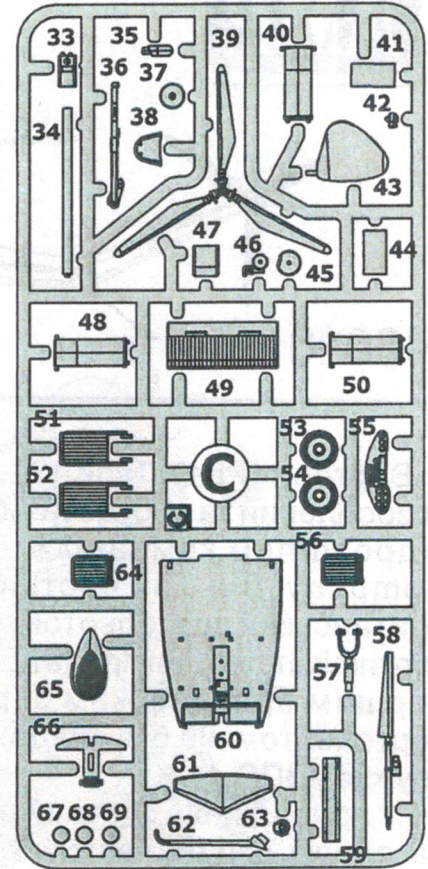
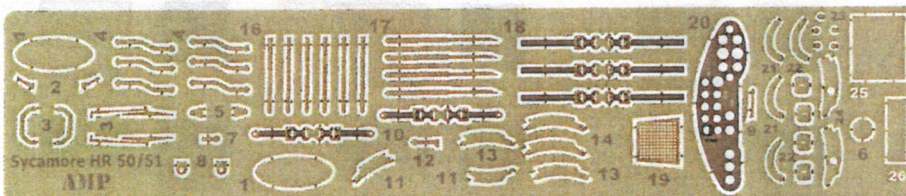

Mask

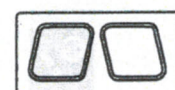
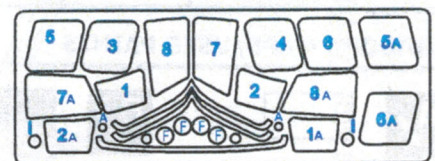

ASSEMBLY INSTRUCTION

1 C61, C55, Pe20

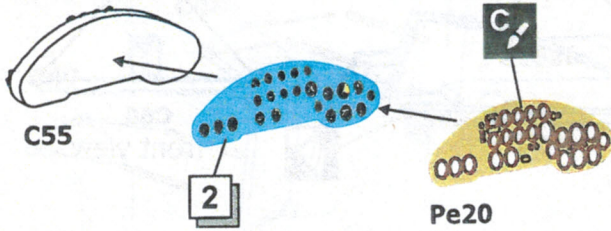

2 C62

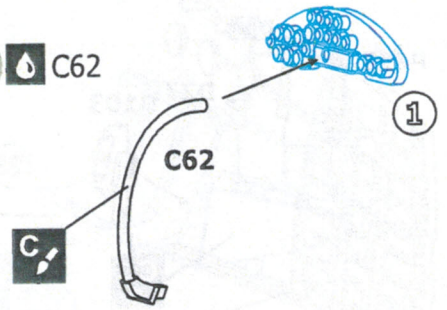

3 C41, C51, C64, D105

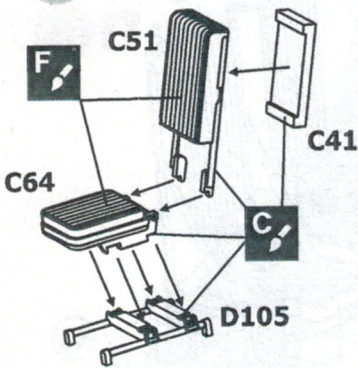

4 C44, C52, C56, D120

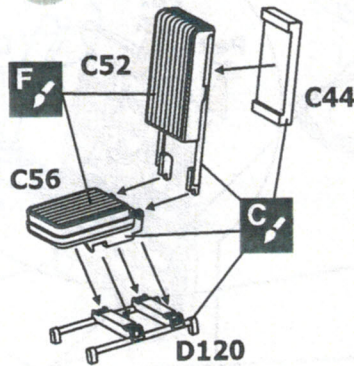

5 Pe17x2, Pe10 Pe23 **x2**

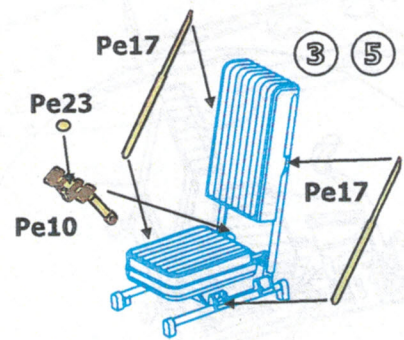

6 A6, C49, D123, Pe19x3, Pe23x3

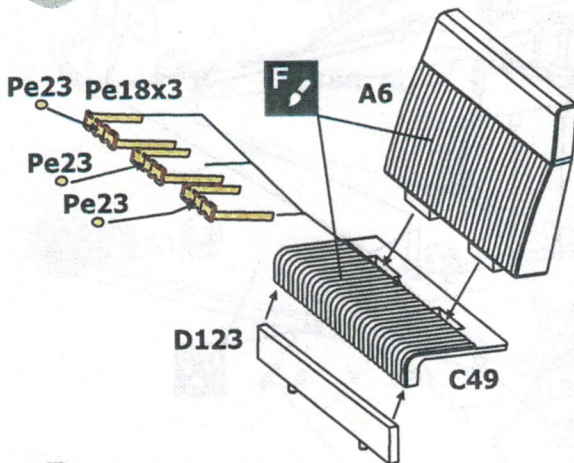

7 C33, C36

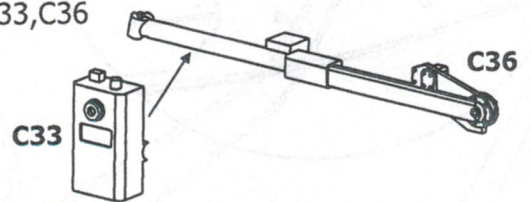

8 D86, D101

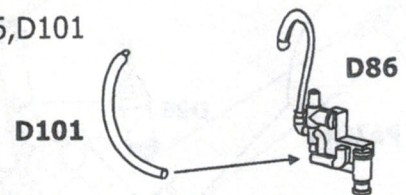

9 C45, C46

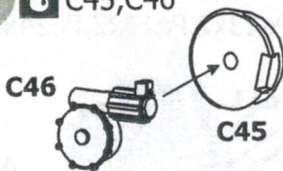

11

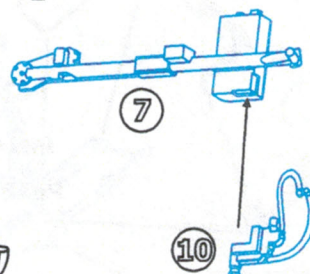

12

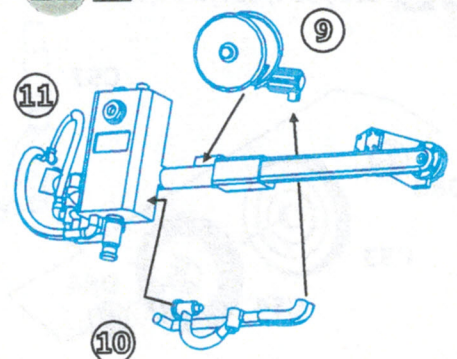

10 D70, D117, D118

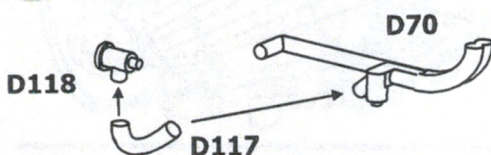

13 D77,D103,Pe9,Pe12

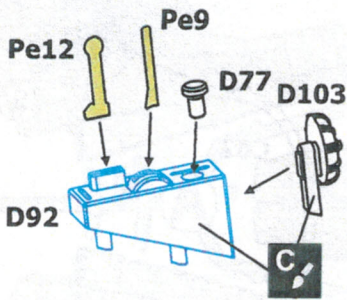

14 C60,D98,D99

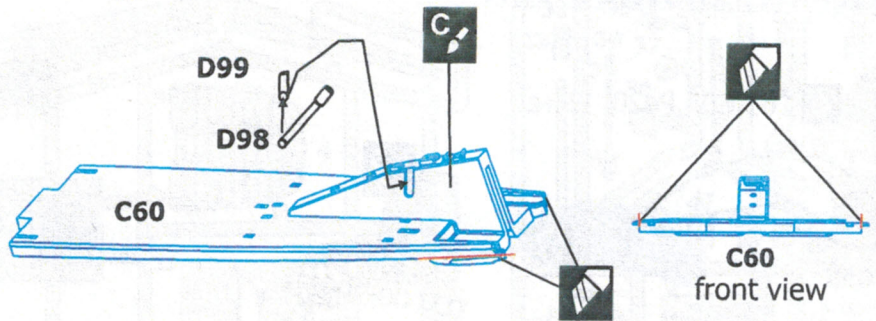

15 C66,D81,D90,D91,D96,D102,Pe2x2,Pe7,Pe21x4,Pe22x4

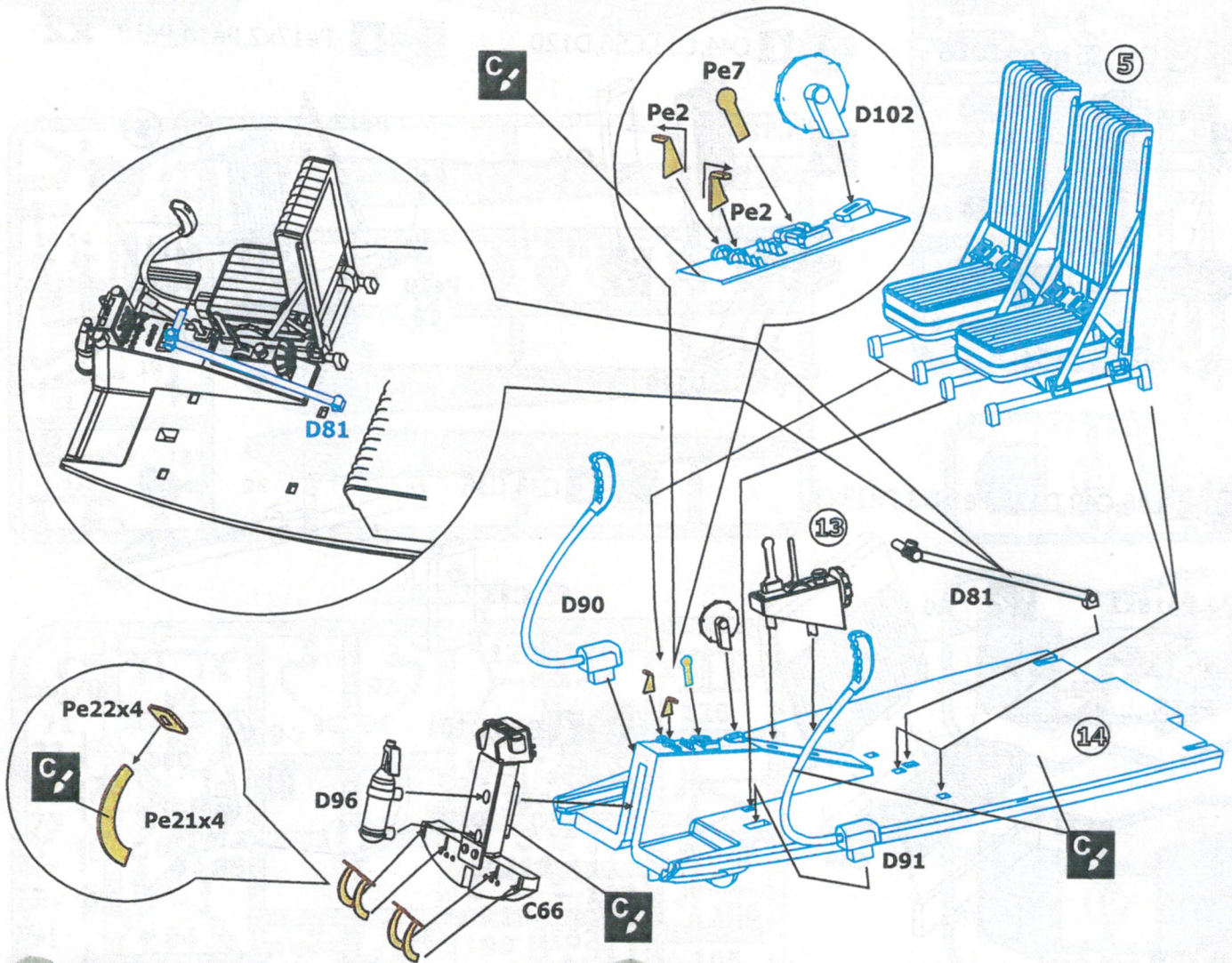

16 C53,C54,C57,D84,D88

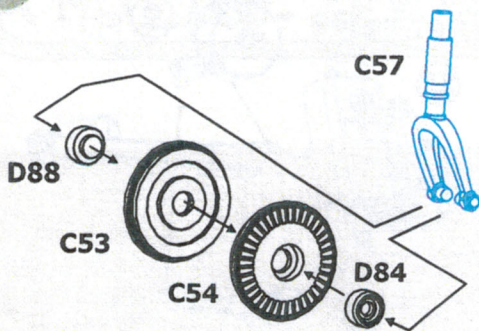

17 A5,C34,C63,Pe11x2,Pe13x2,Pe14x2,Pe24x2

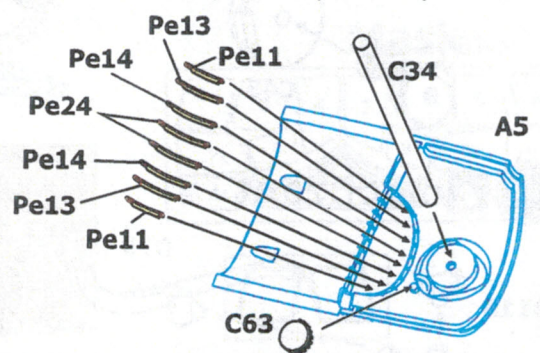

18 C40,C48,C50,Pe16x6

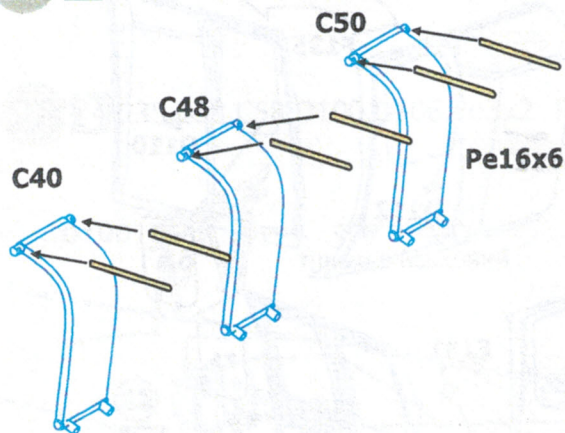

19 A3,A4,C67-69

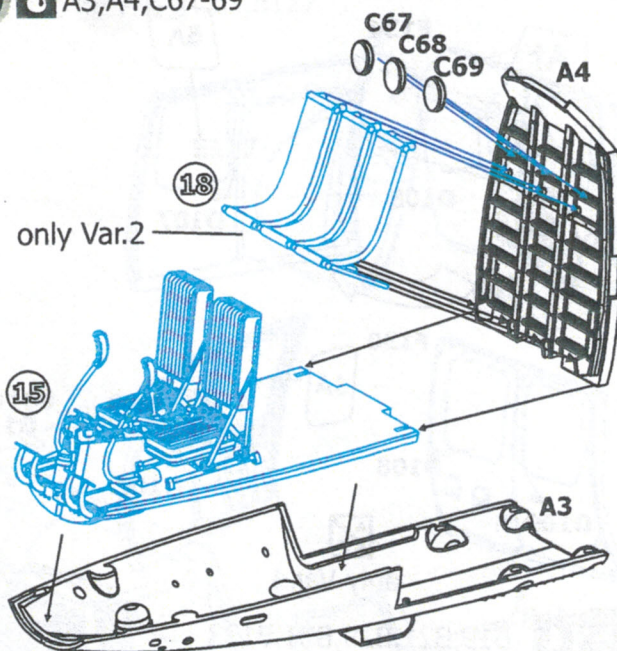

20 A3,A4

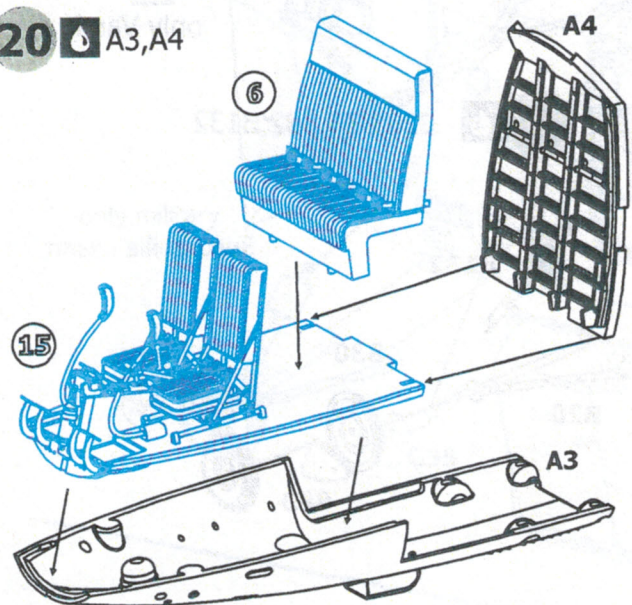

21 A1,A2

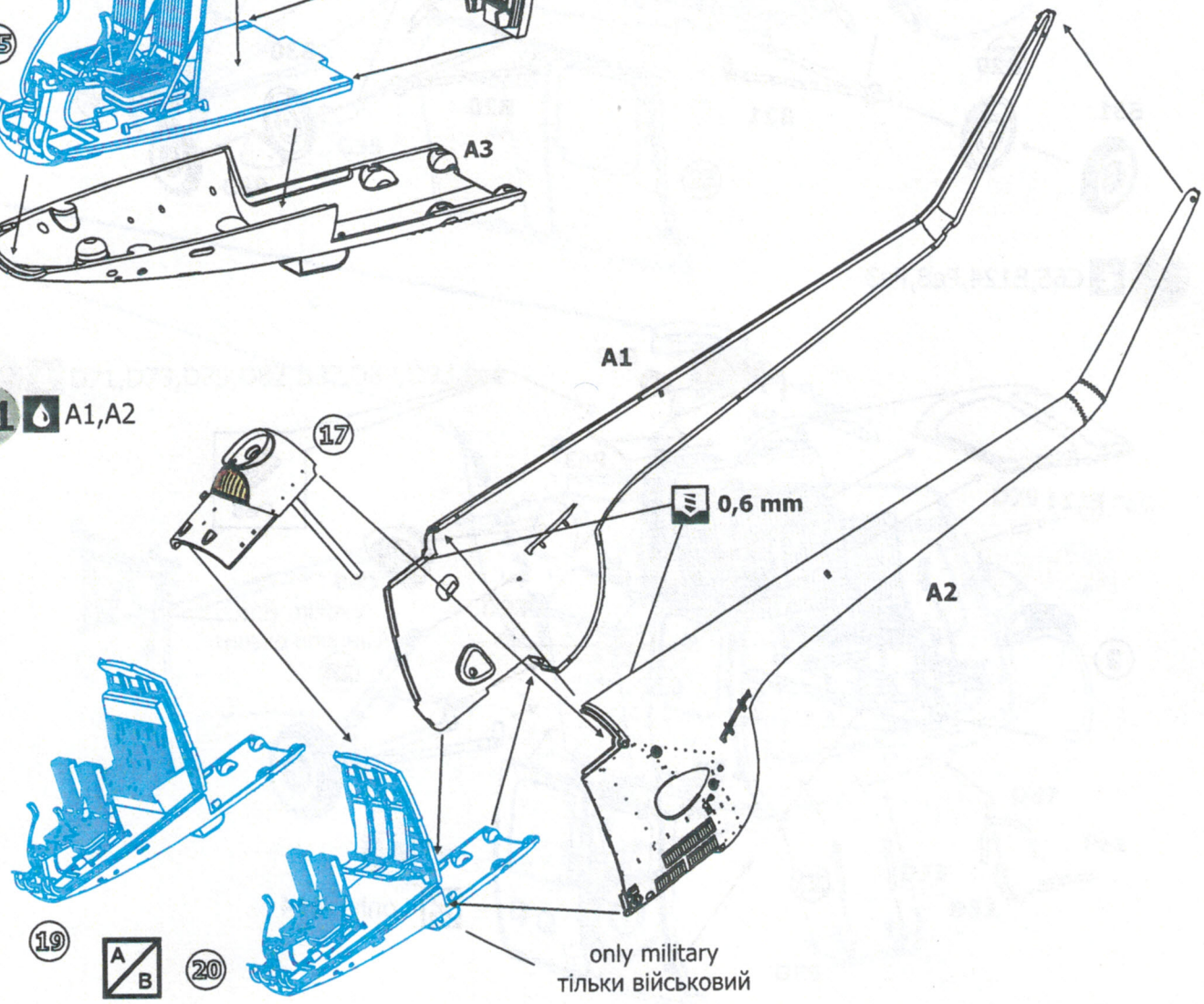

22 D107,D108,D109,D130

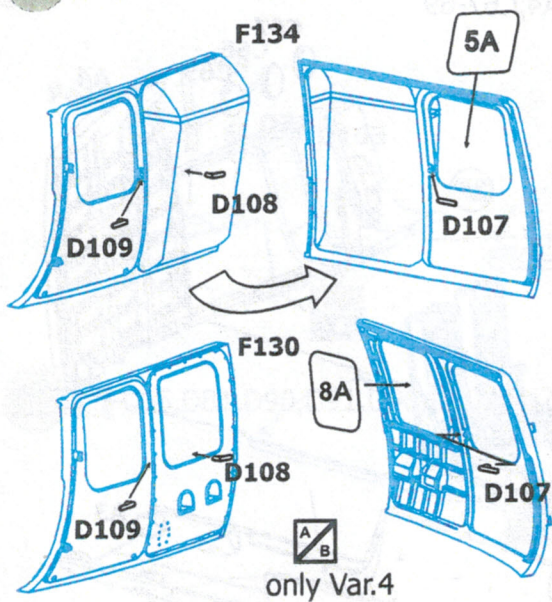

23 D110,D111,D112,D131

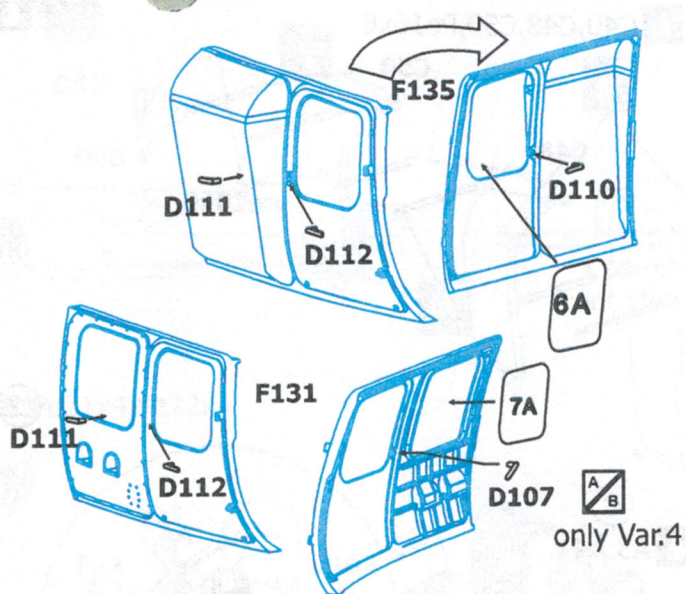

24 B19,B21,B29,B31,B133

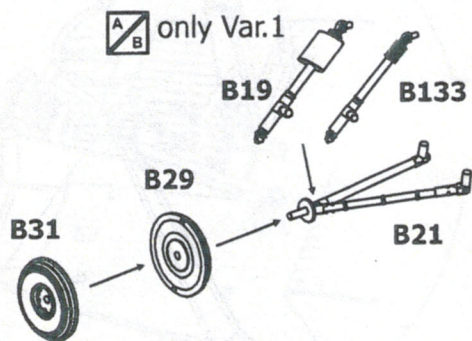

25 B20,B30,B32,B132

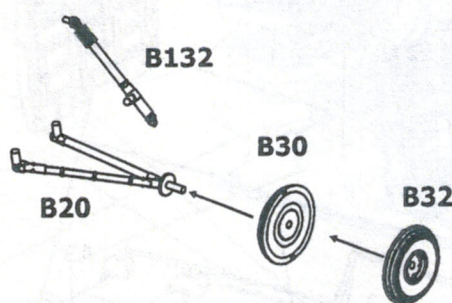

26 C65,E124,Pe8,Pe3

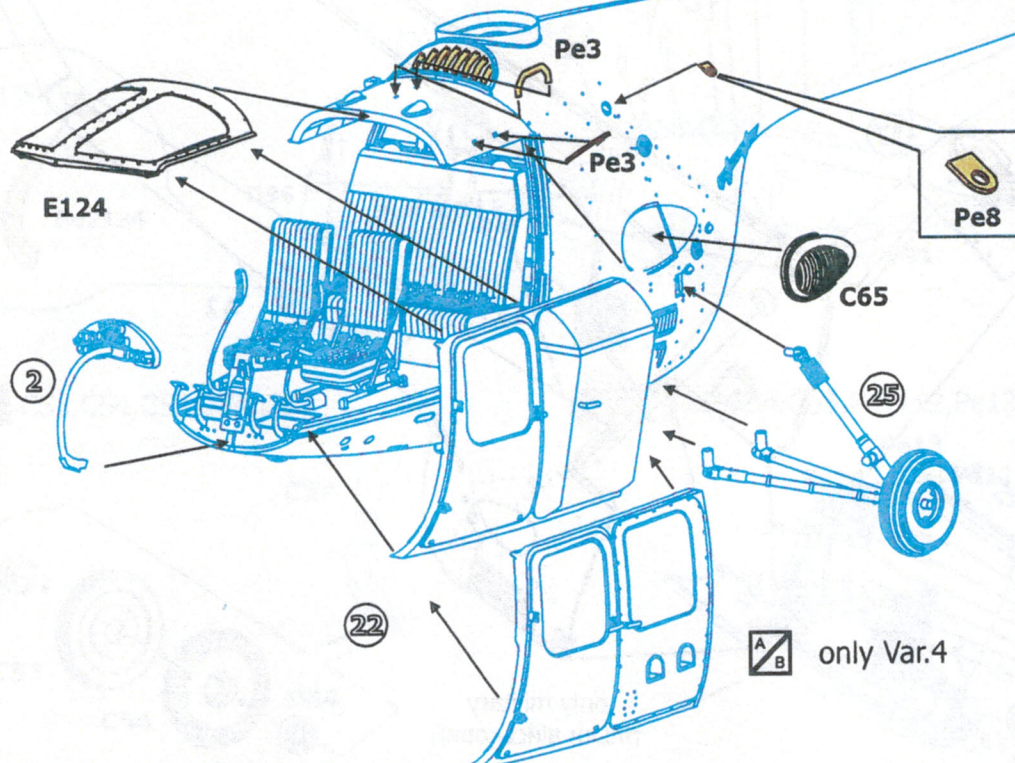

27  C61,E127

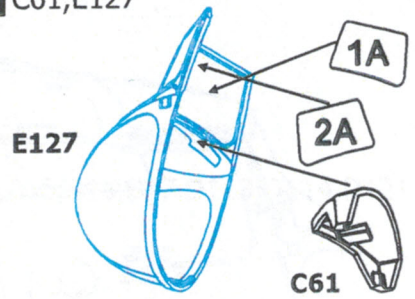

28  C35,C38,C58,D100,D106,Pe3x2 Pe8

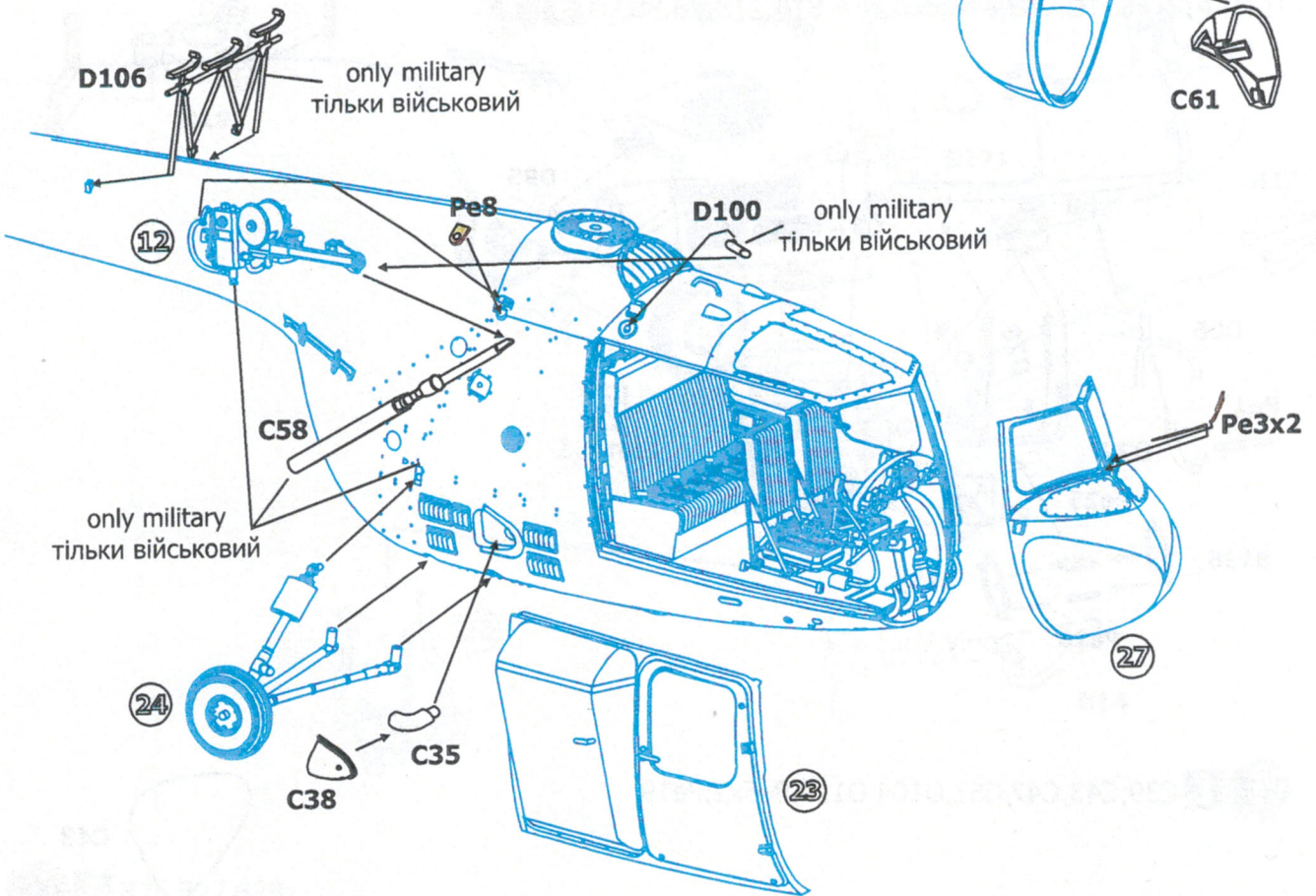

29  D71,D73,D79,D82,D87,D89,D93,Pe1

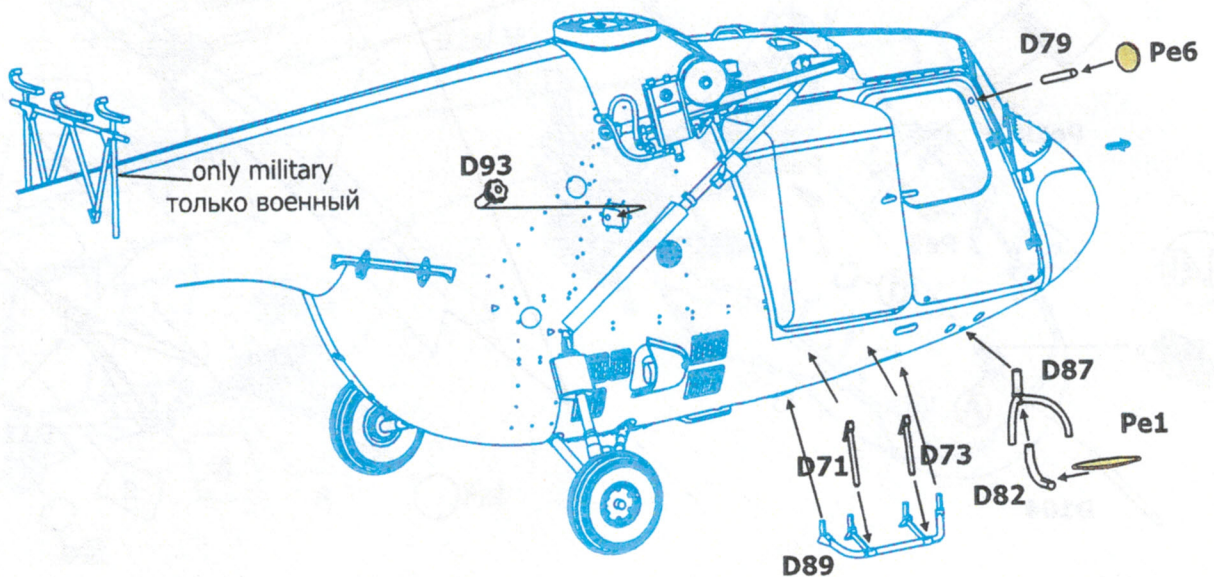

30 ▣ D72,D74,D78,D83,D85,D94,D95,Pe1

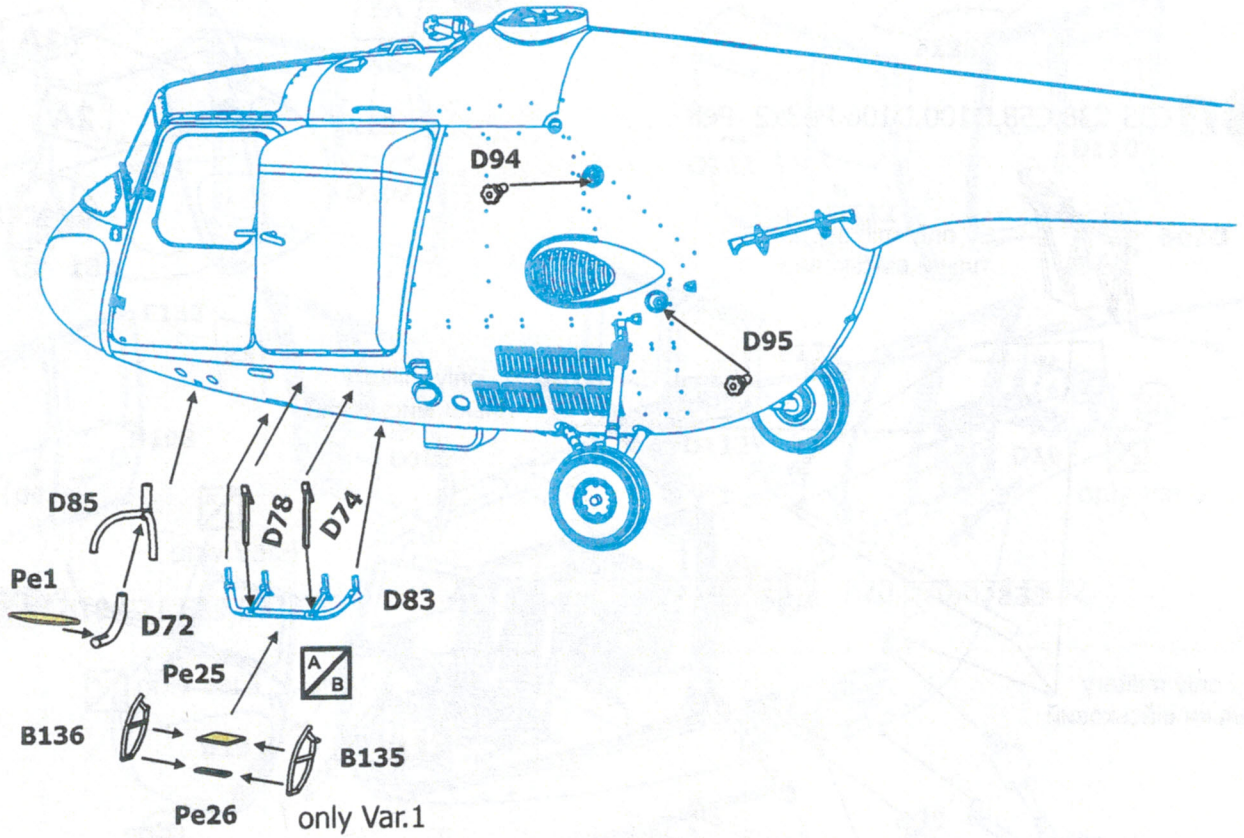

31 ▣ C39,C43,C62,D104,D119,Pe5x2,Pe19

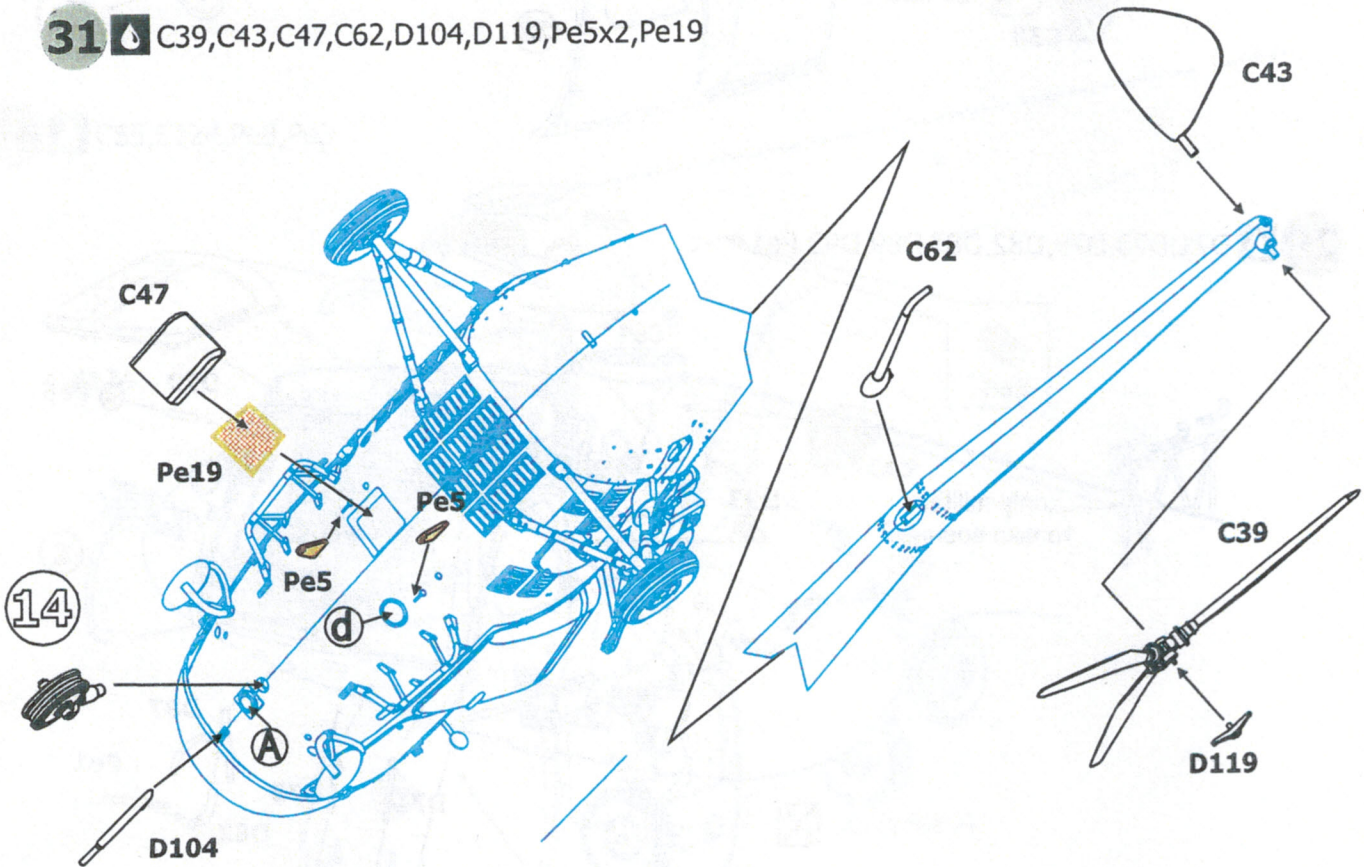

32  B19, Pe4x3

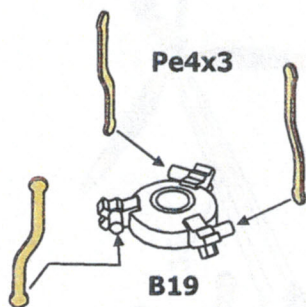

33  B7, B8, B9, B11, B13, B14, B15, B16, B17, D113, D114, D121

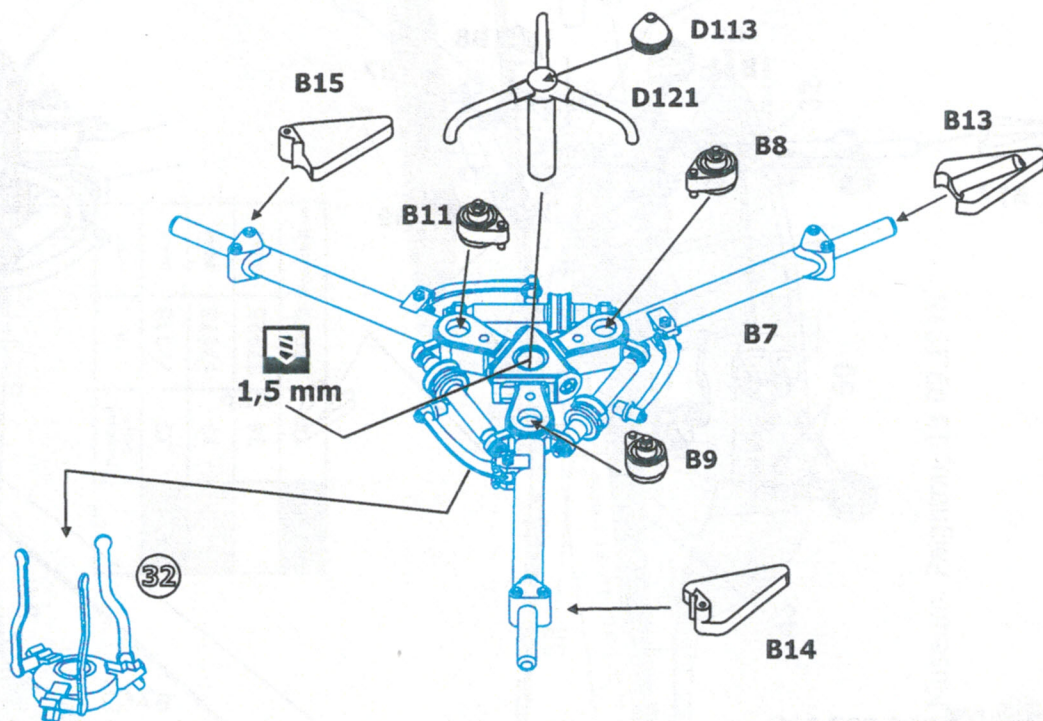

34  B26, B27, B28

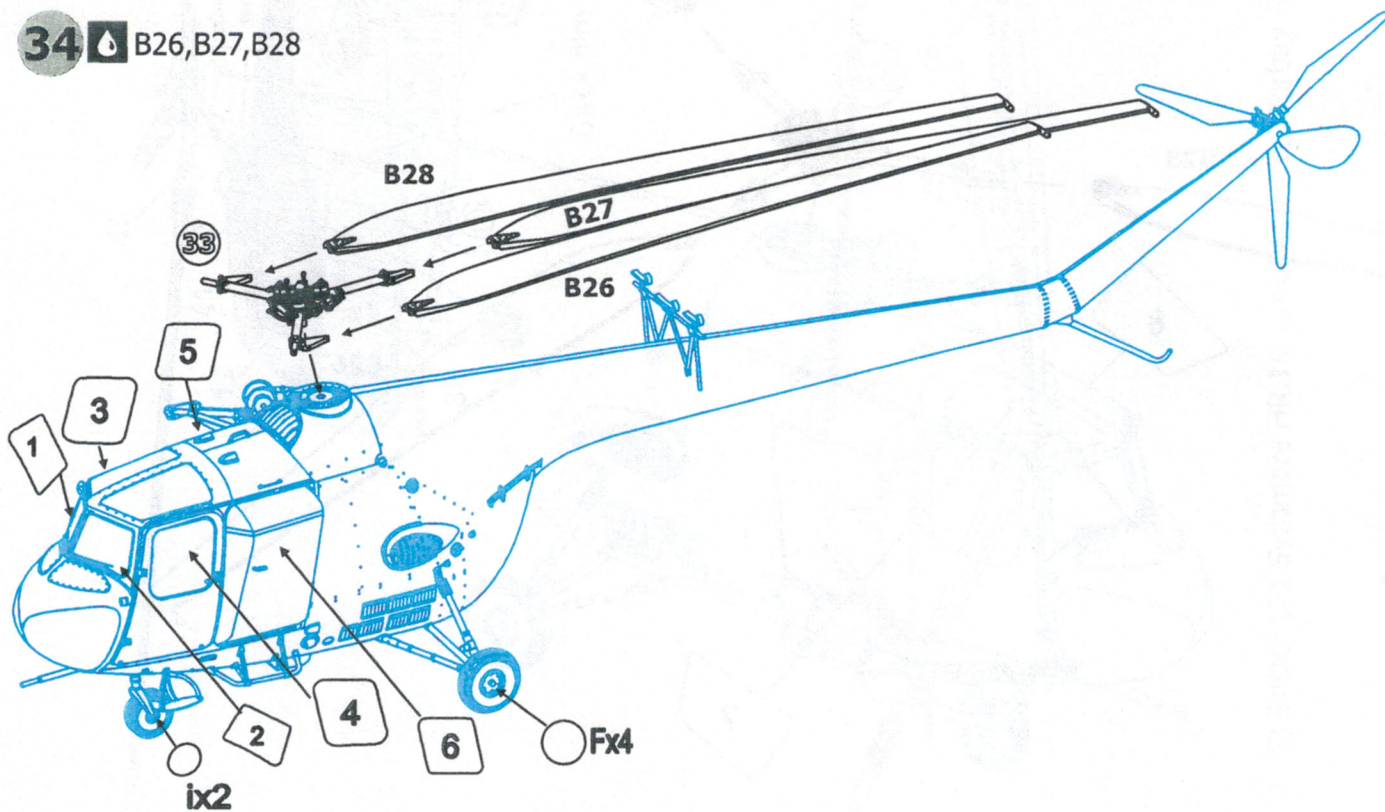

35 B7,B8,B9,B11,B13,B14,B15,B16,B17,D113,D114,D121

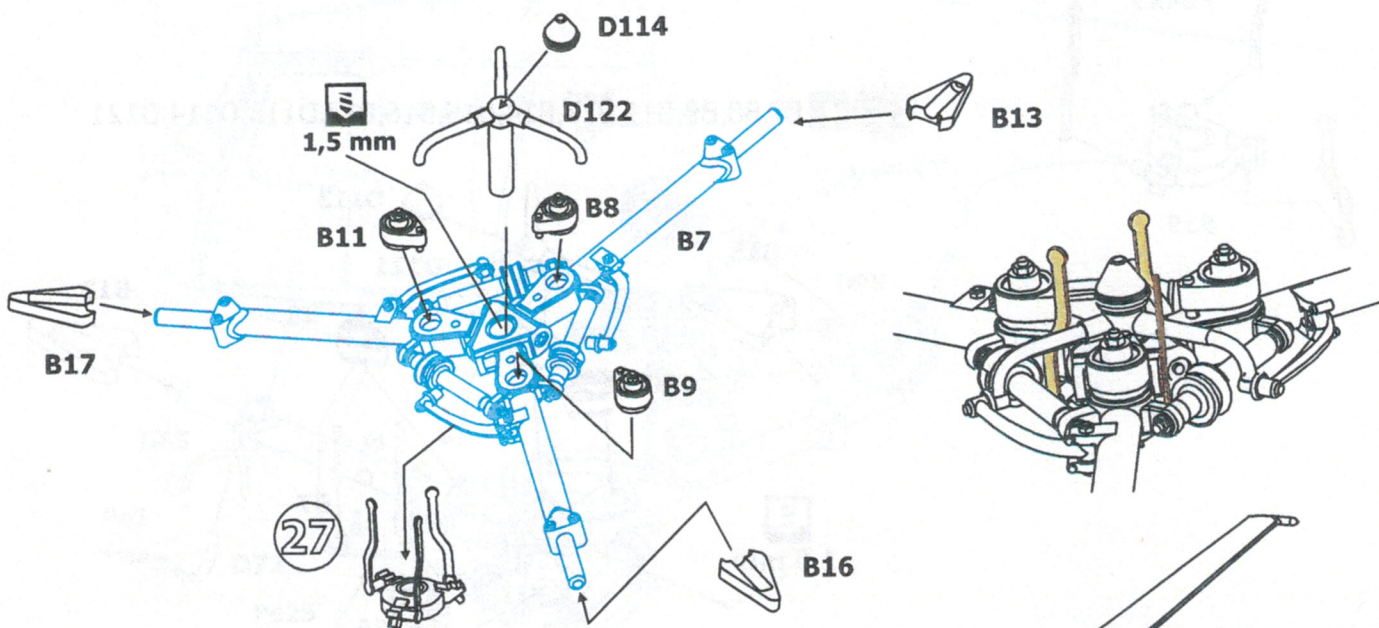

36 B26,B27,B28

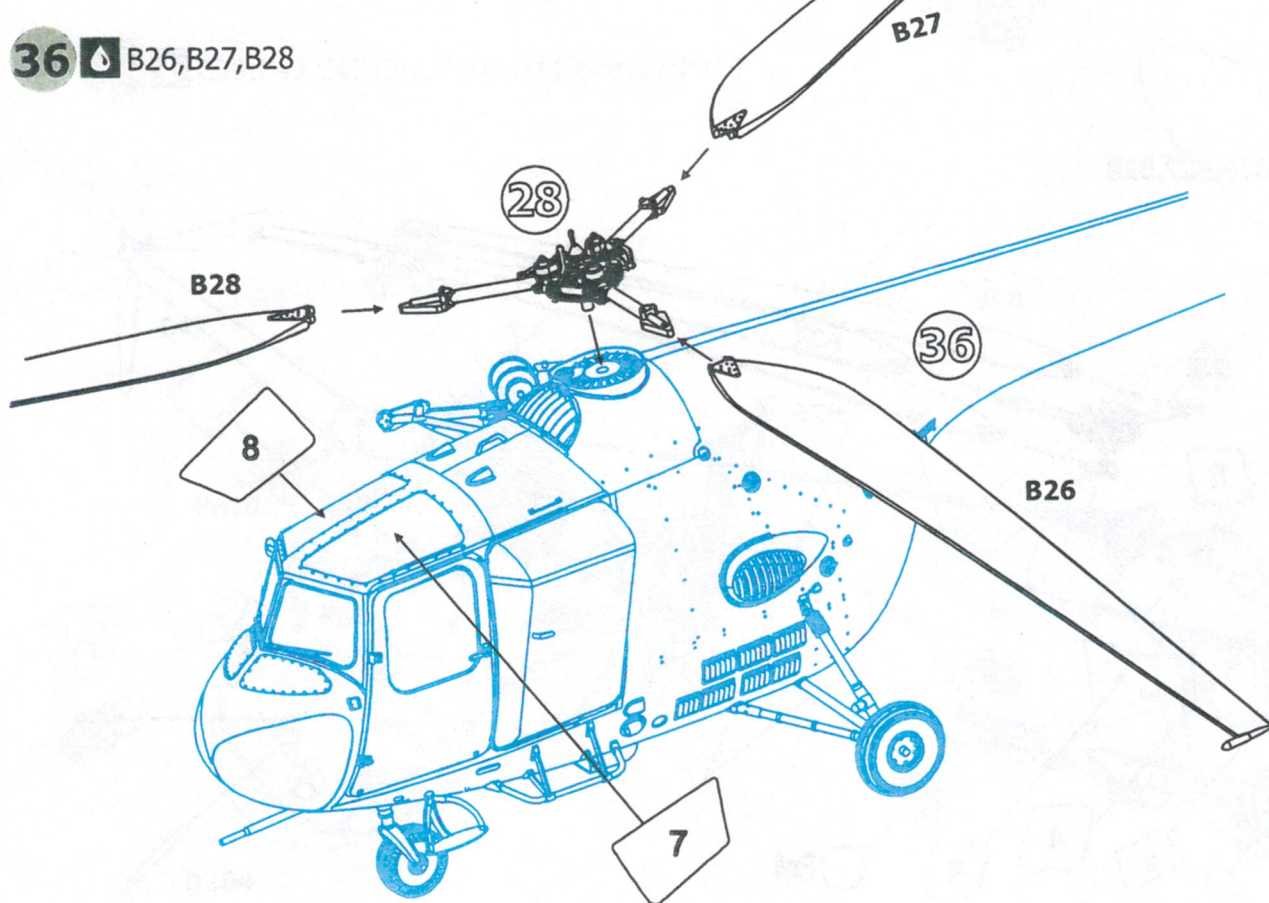

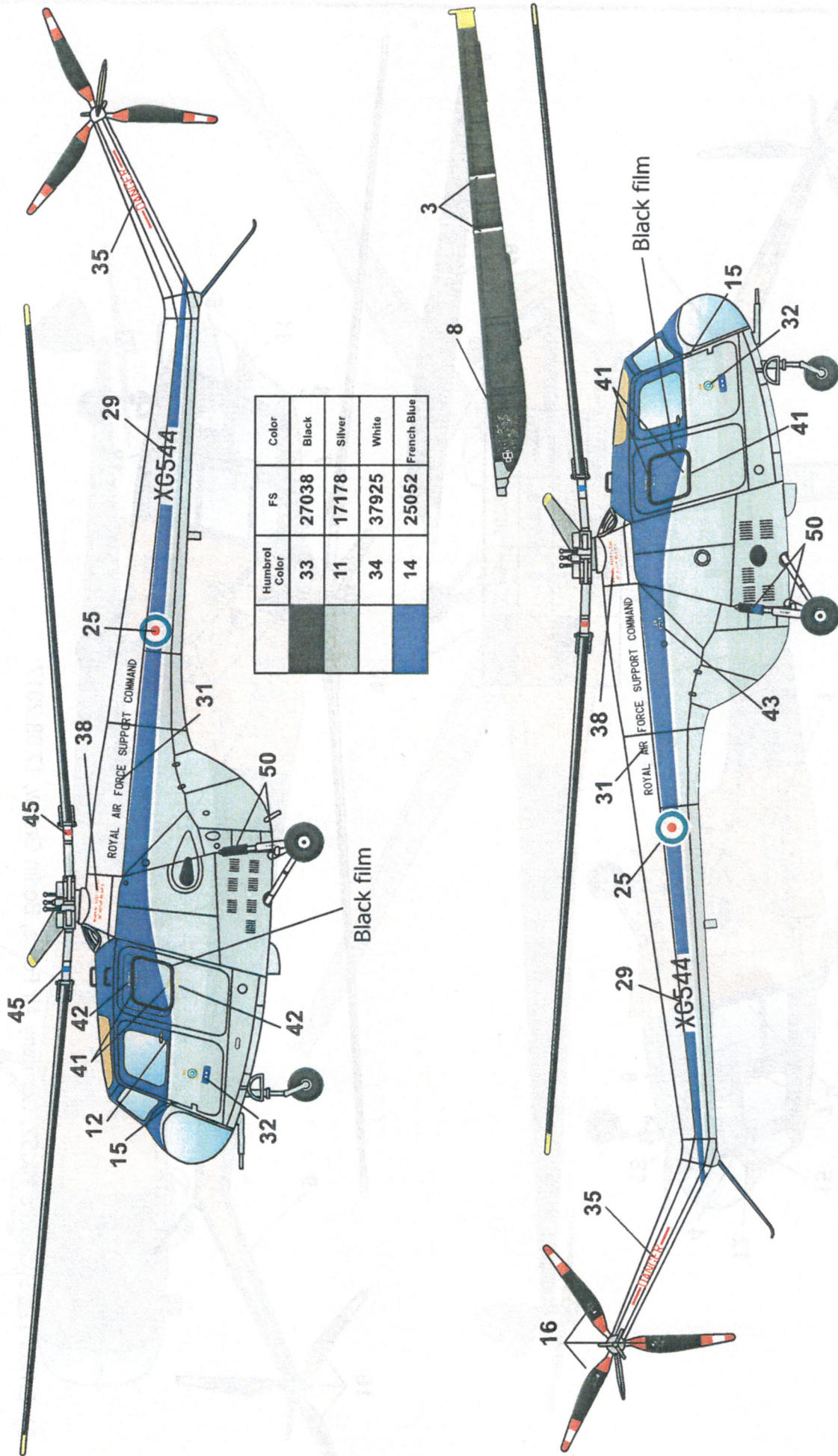

1) Bristol 171 Sycamore HR.14, Royal Air Force, Torbay Aircraft Museum, Paignton, 13.09.1976

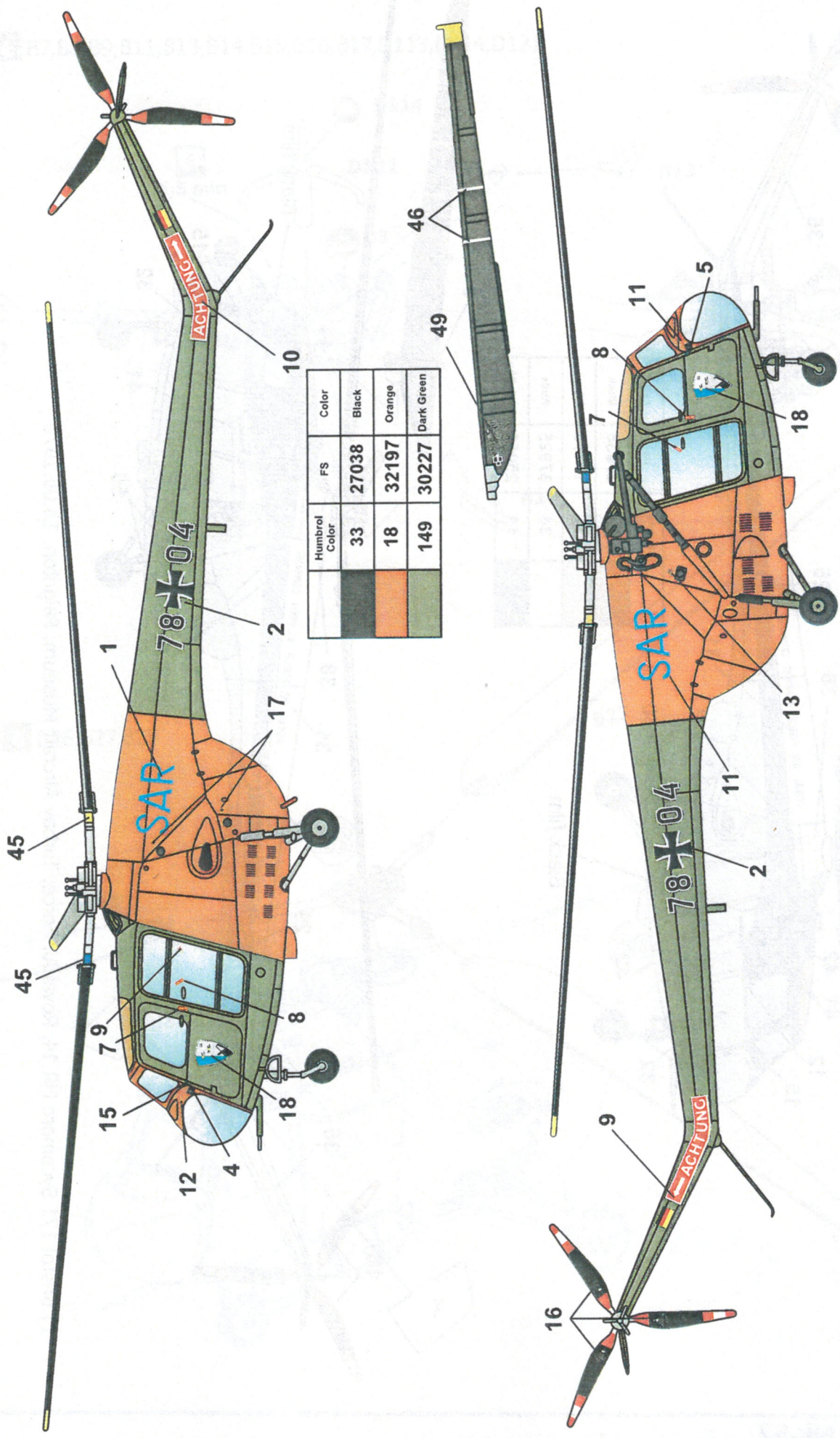

2) Bristol 171 Sycamore Mk.52, Germany Air Force, Berlin Gatow, 17.08.2017

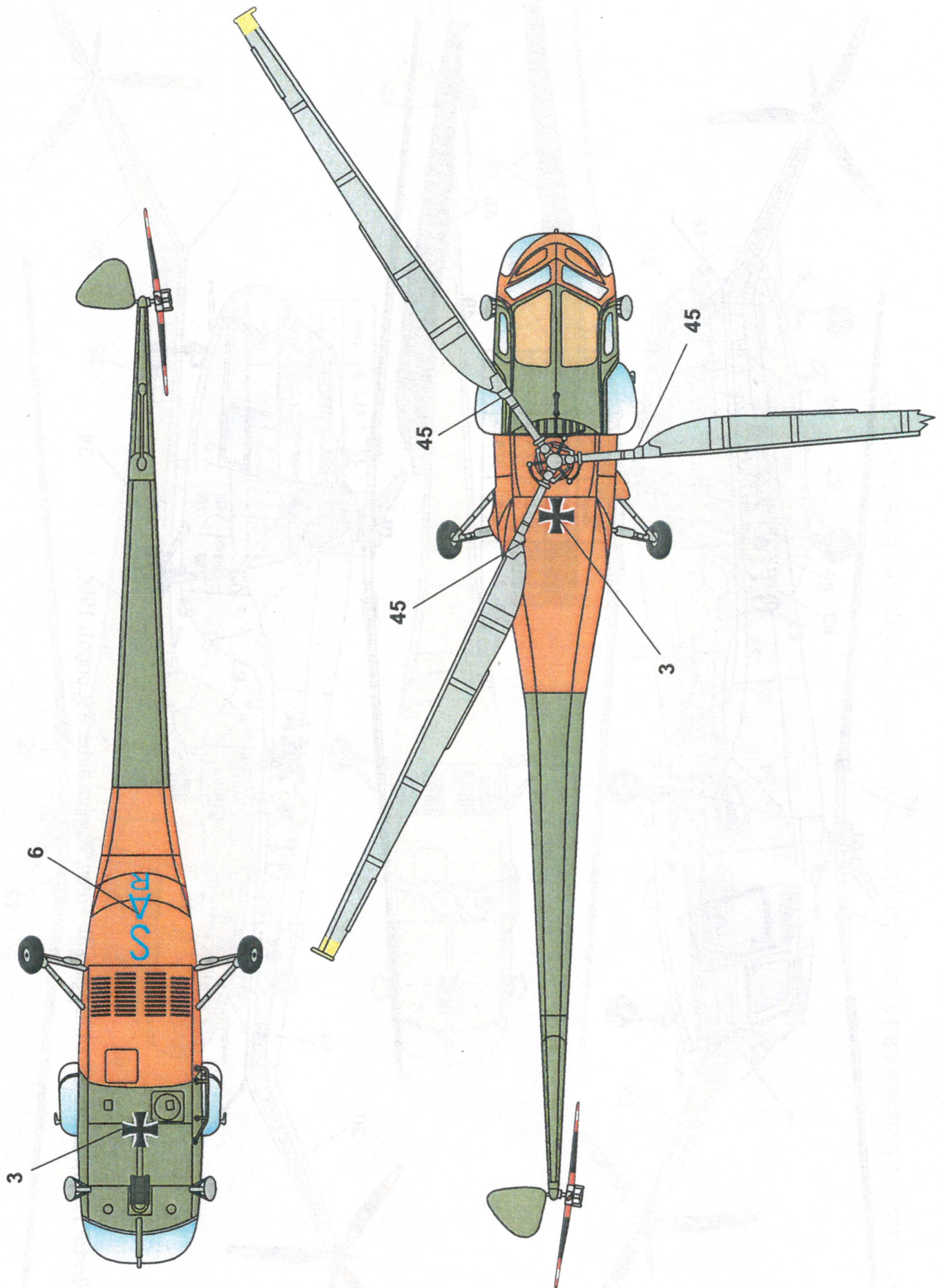

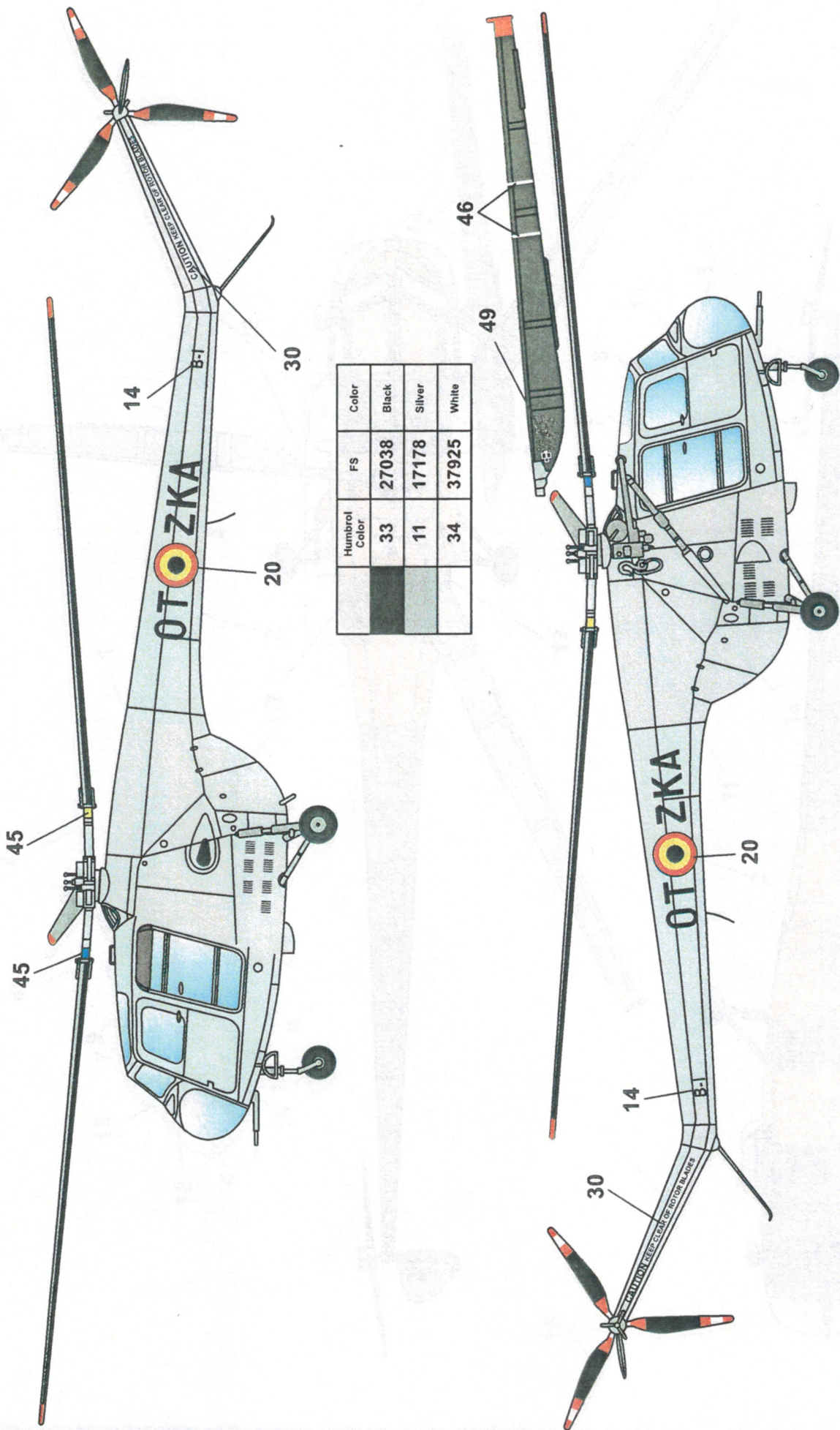

3) Bristol 171 Sycamore HR.14, Belgian Air Force, Kamina airbase (Congo), 1954

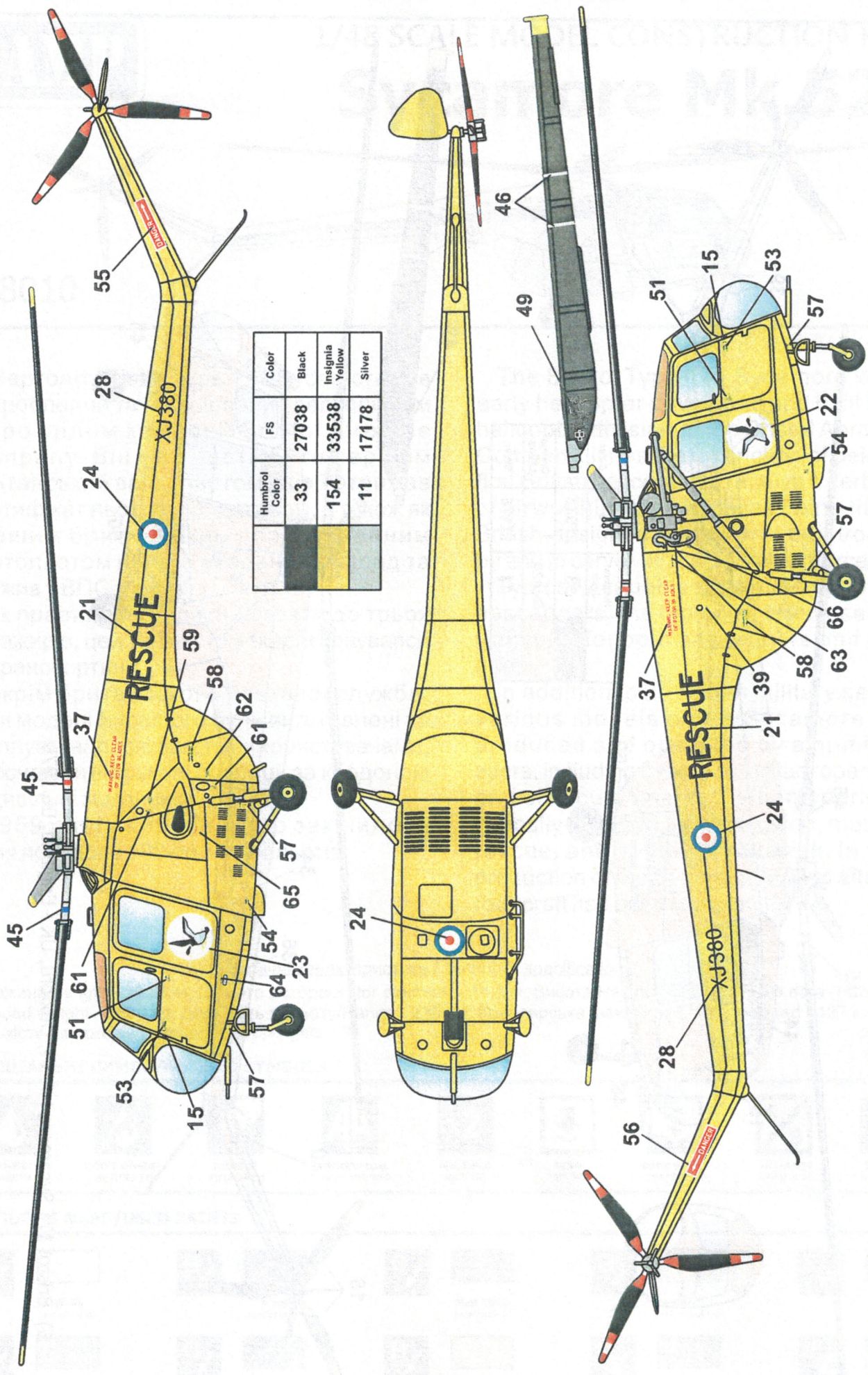

Humbrol Color	FS	Color
33	27038	Black
154	33538	Insignia Yellow
11	17178	Silver

4) Bristol 171 Sycamore HR.14, United Kingdom, Royal Air Force , Finningley Air Base , 17.09.1983

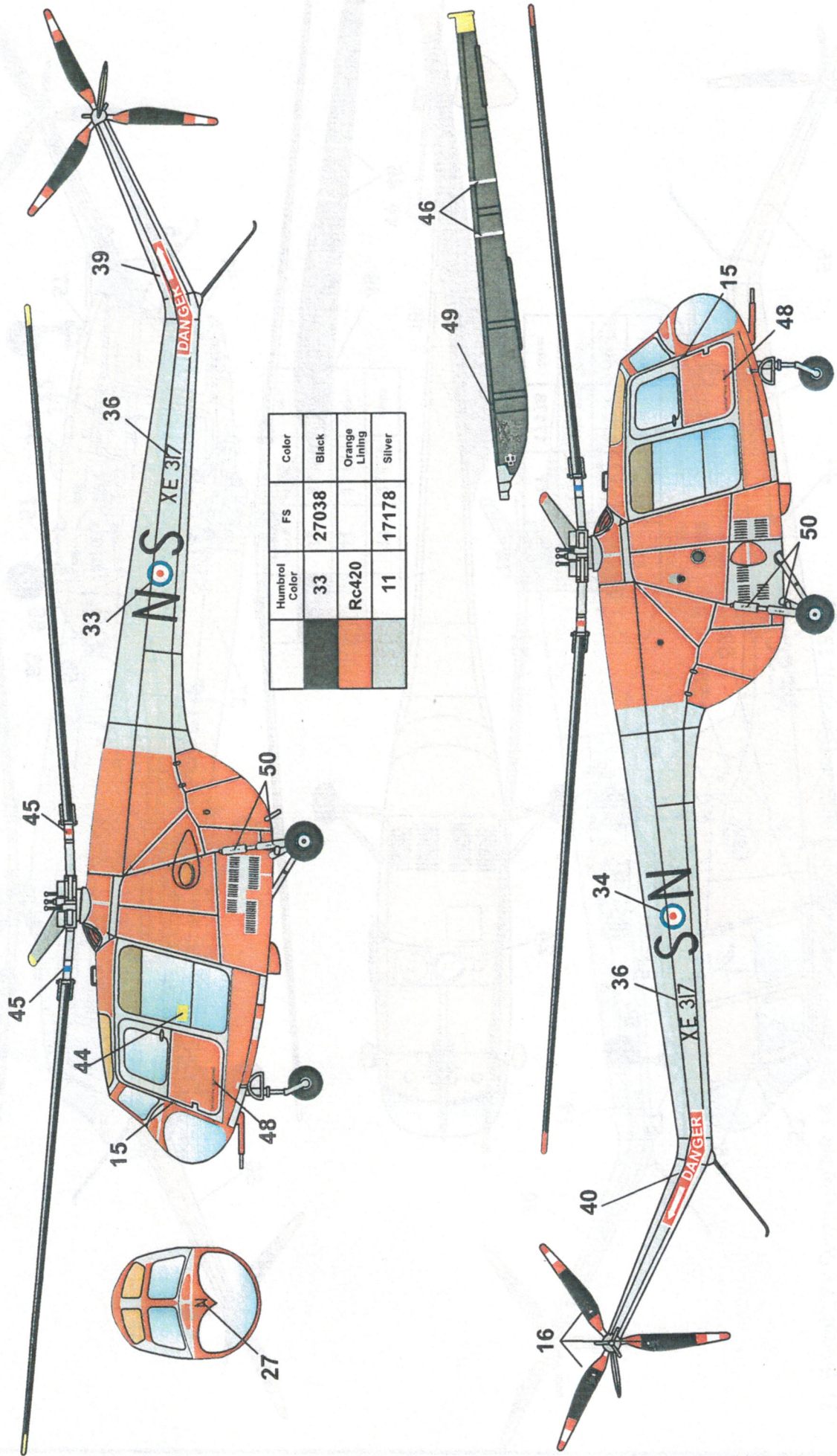

5) Bristol 171 Sycamore HR.14, Duxford, UK - England, 06.1978