

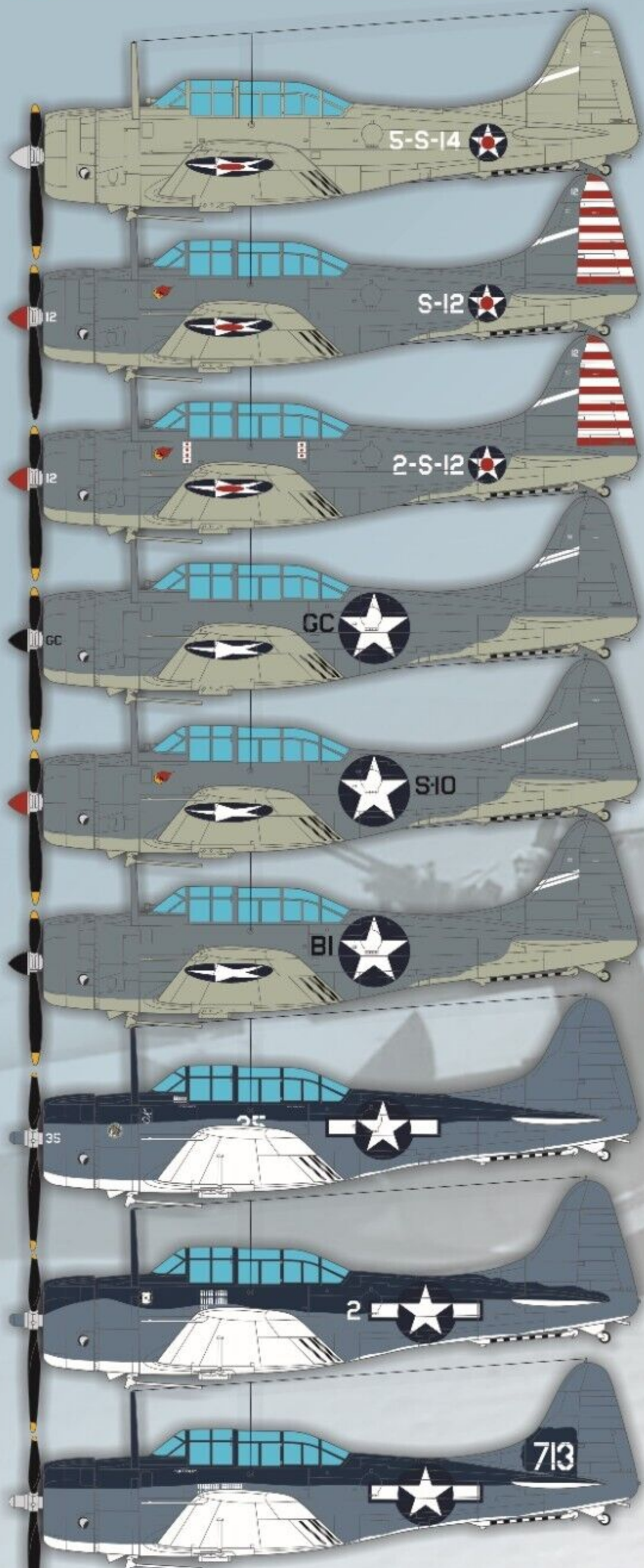

FURBALL
*** AERO-DESIGN ***
DETAIL & SCALE



COLORS AND MARKINGS OF U.S. SBDs



OPTIONS FOR
(18)SBD-3/4/5/6/A-24B



RESEARCH MATERIALS
PROVIDED BY
DETAIL & SCALE
www.detailandscale.com

FS 36440 FS 35189 FS 31136 FS 37038
VS-5 SBD-3
USS YORKTOWN
 1941

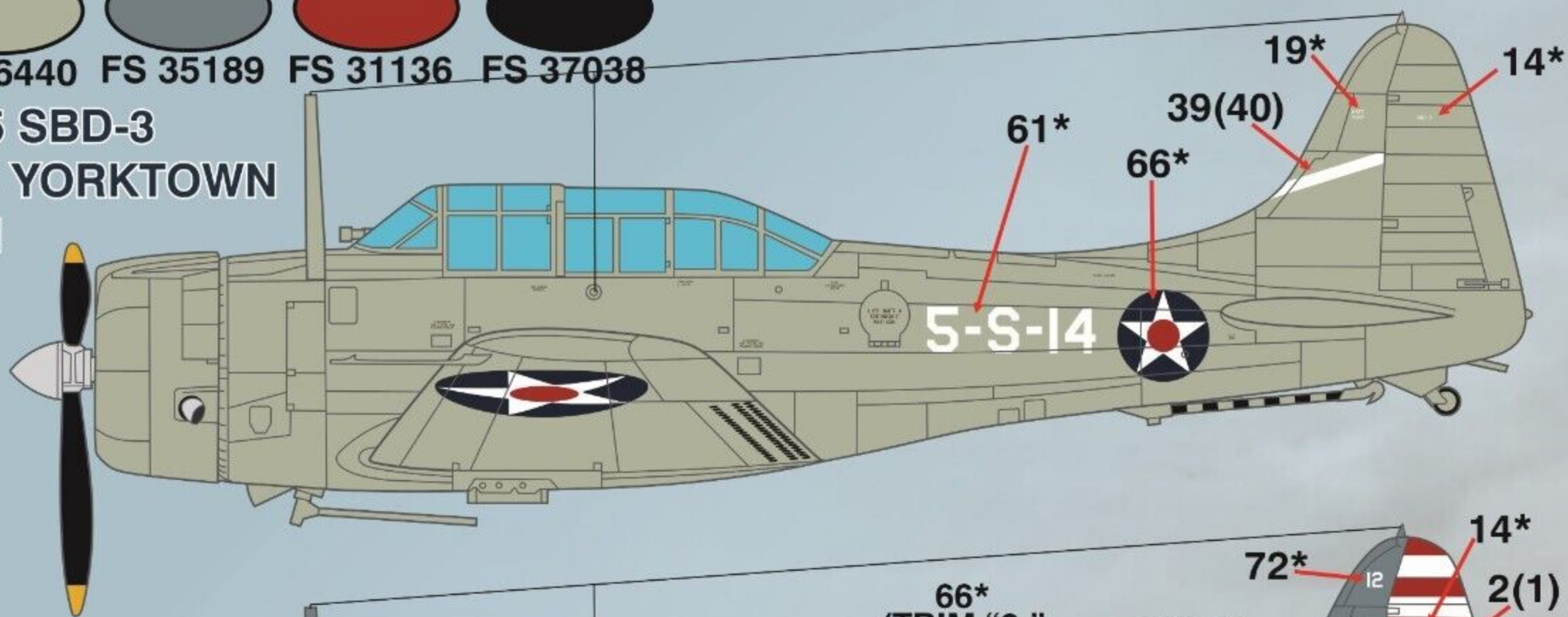

VS-2 SBD-3
USS LEXINGTON
 1942

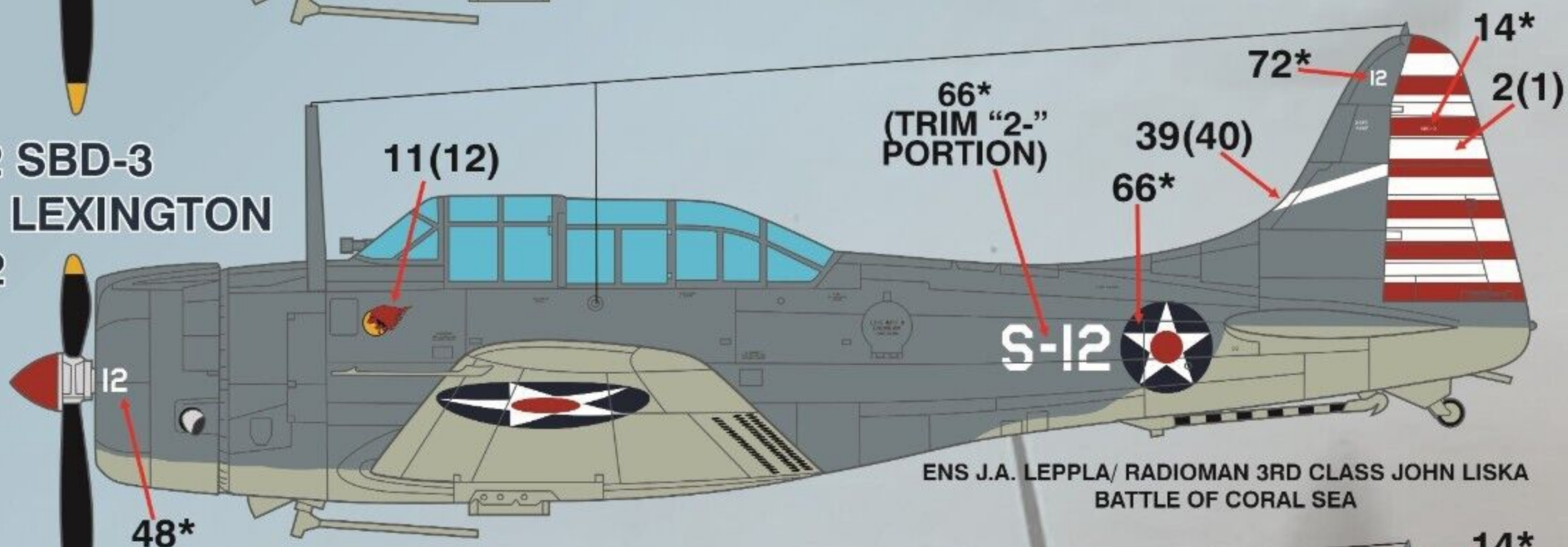

VS-2 SBD-3
USS LEXINGTON
 1942

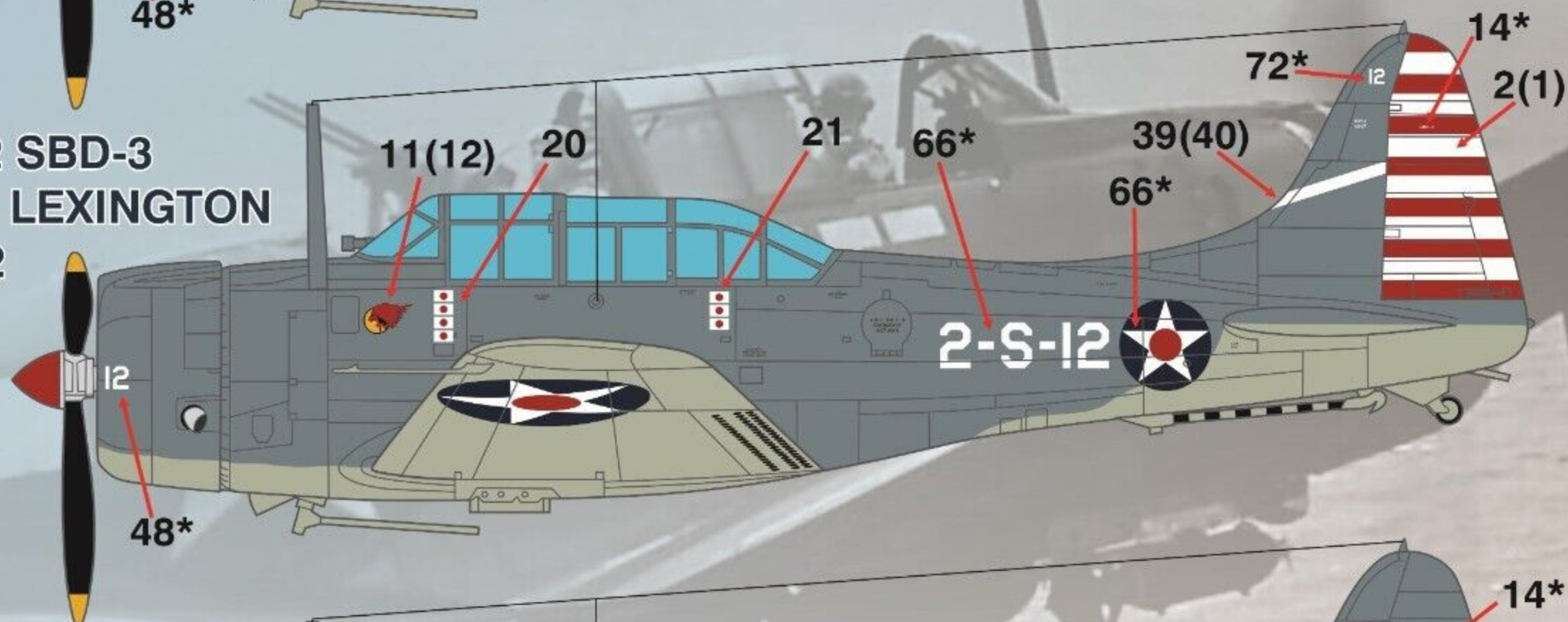

VB-6 SBD-3
USS ENTERPRISE
 JUNE 1942

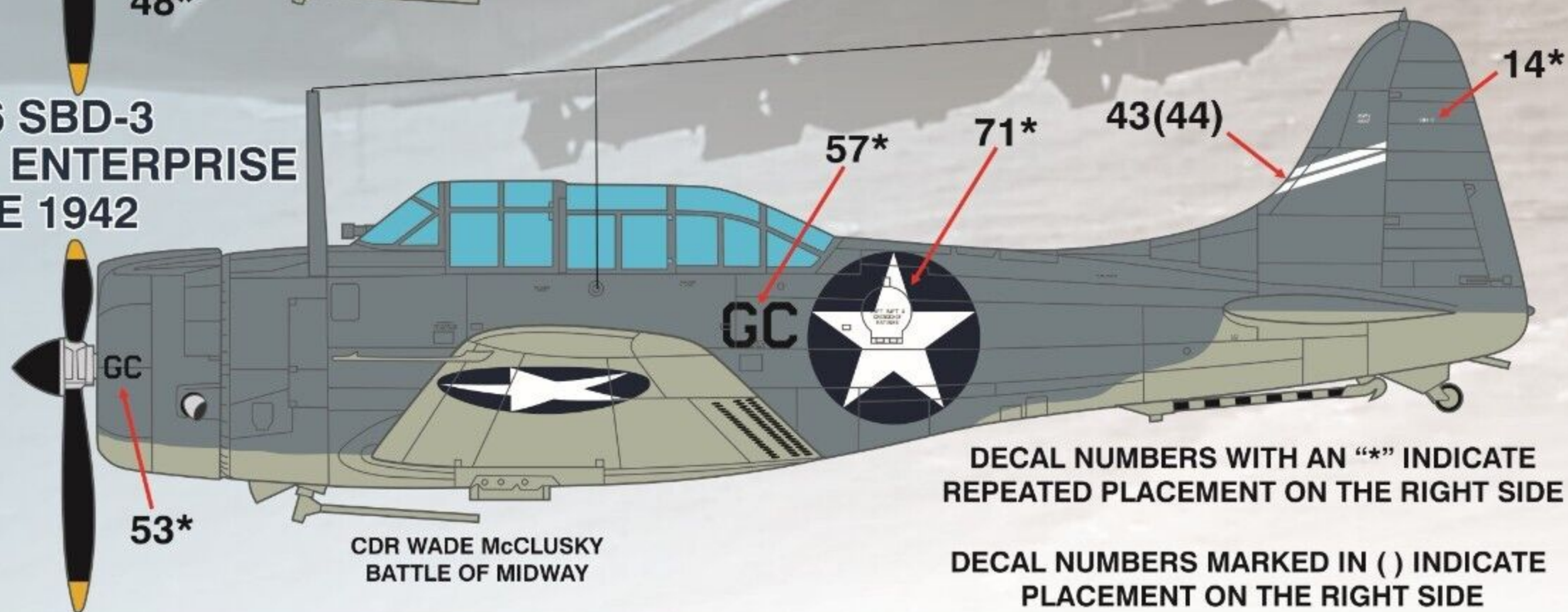

CDR WADE McCLUSKY
 BATTLE OF MIDWAY

DECAL NUMBERS WITH AN "*" INDICATE
 REPEATED PLACEMENT ON THE RIGHT SIDE

DECAL NUMBERS MARKED IN () INDICATE
 PLACEMENT ON THE RIGHT SIDE

VS-2 SBD-3
1942

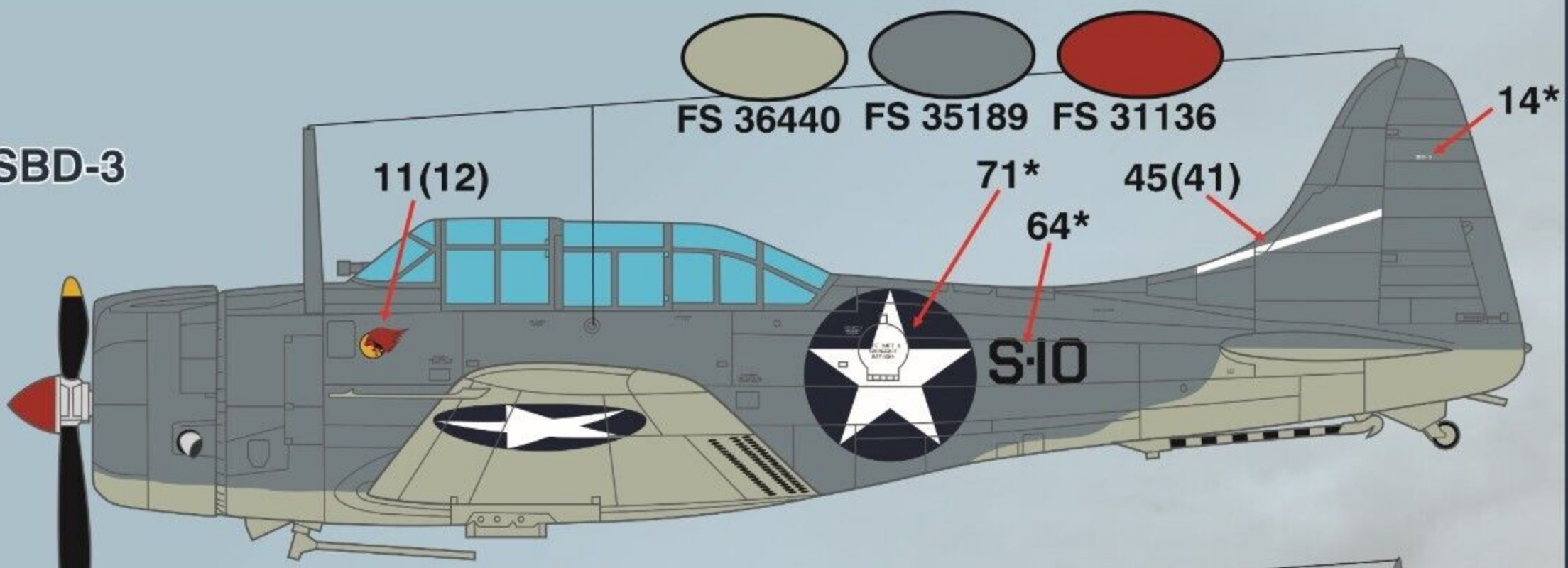

VB-6 SBD-3
USS ENTERPRISE
JUNE 1942

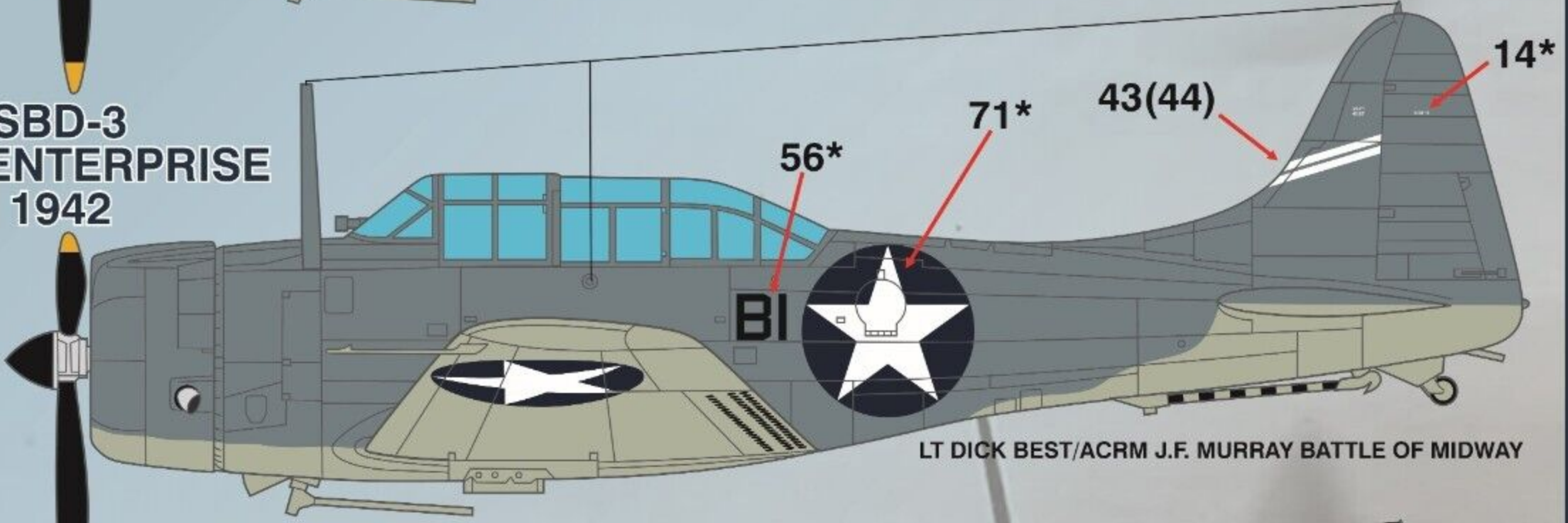

VB-16 SBD-5
USS LEXINGTON
1944

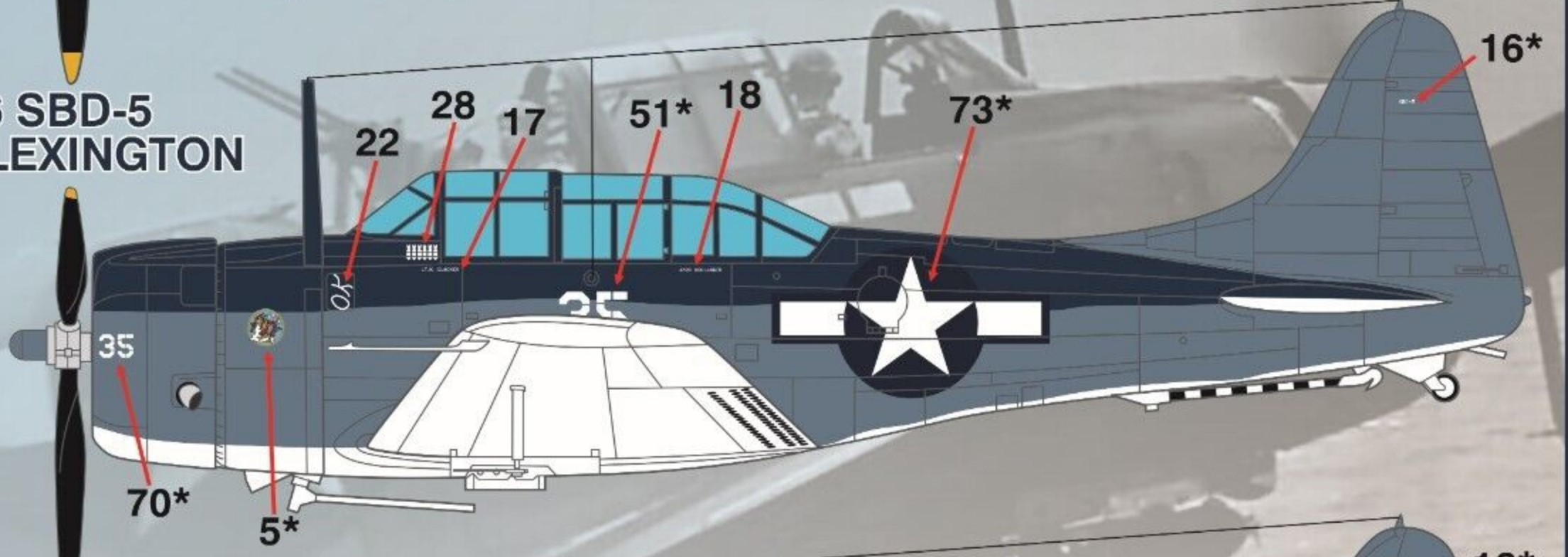

VMSB-231 SBD-5
1944

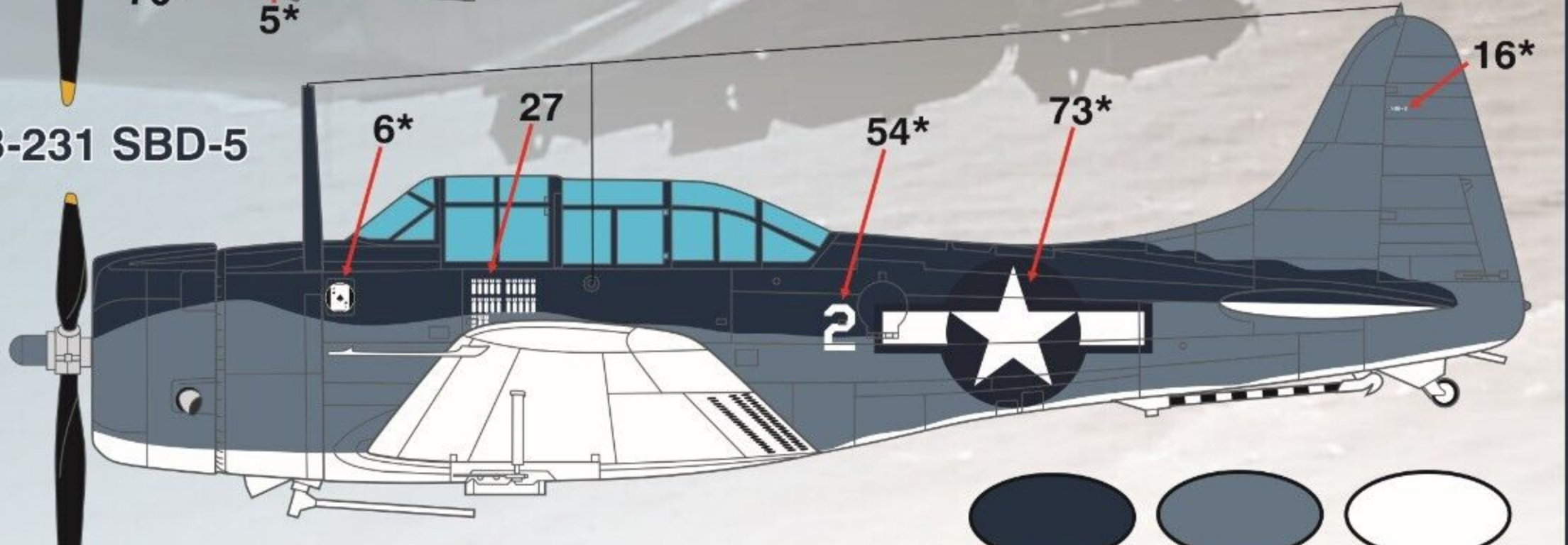

FS 25044 FS 35164 FS 37875

MAG-24 SBD-6
1945

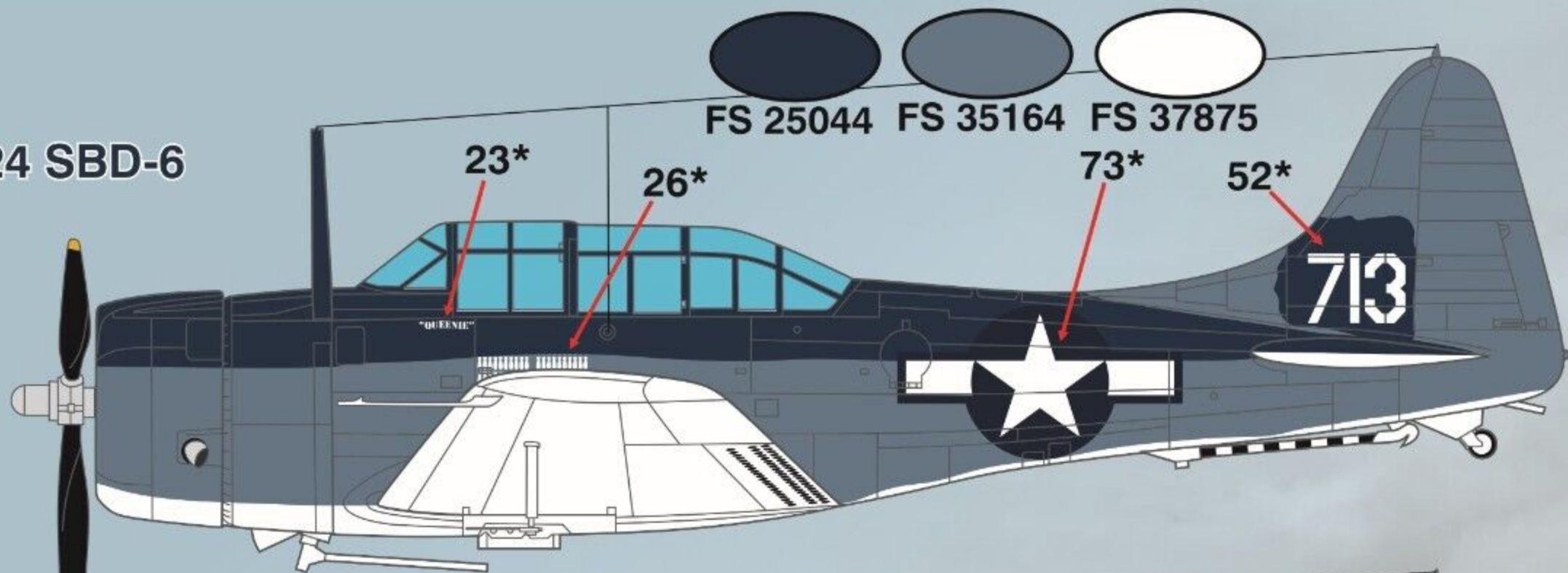

VS-64 SBD-5
1943

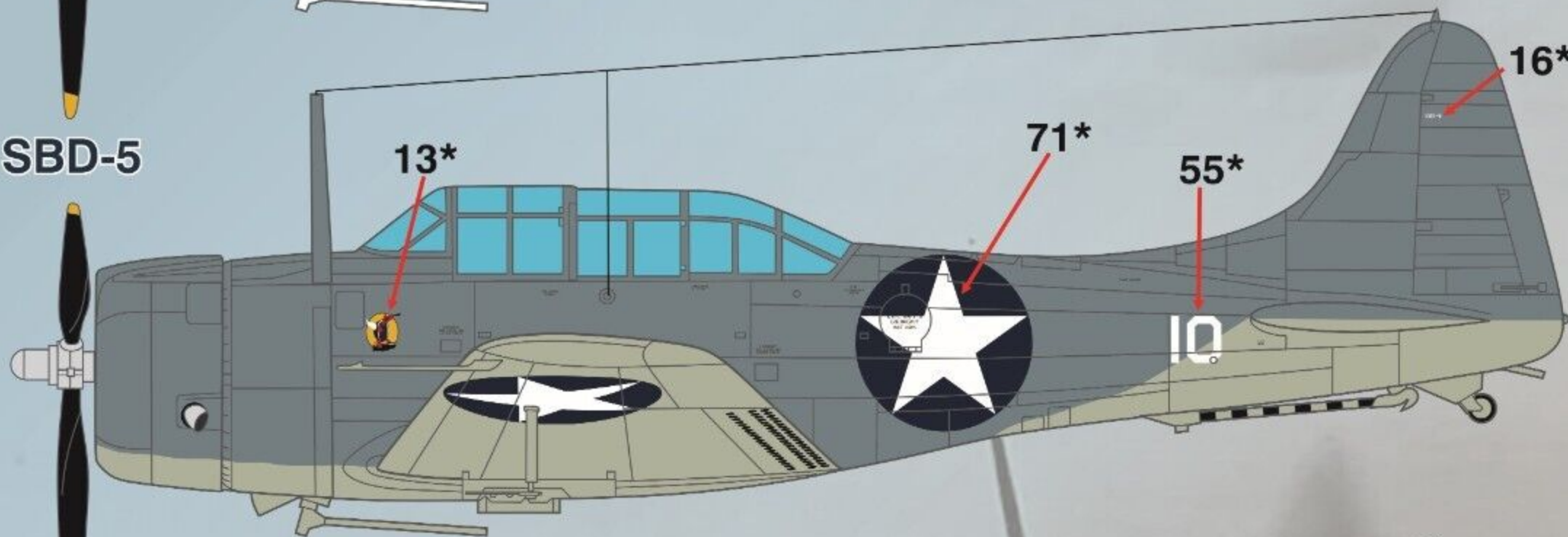

VMS-3 SBD-5
1944

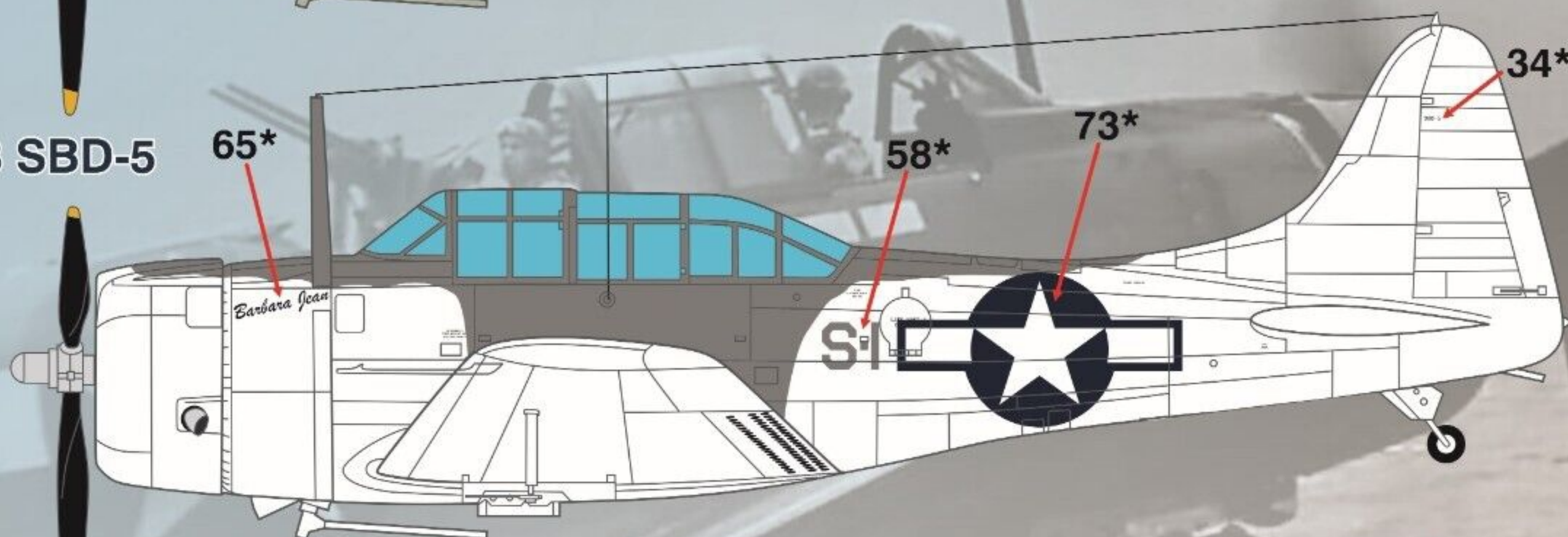

MAG-24 SBD-5
1945

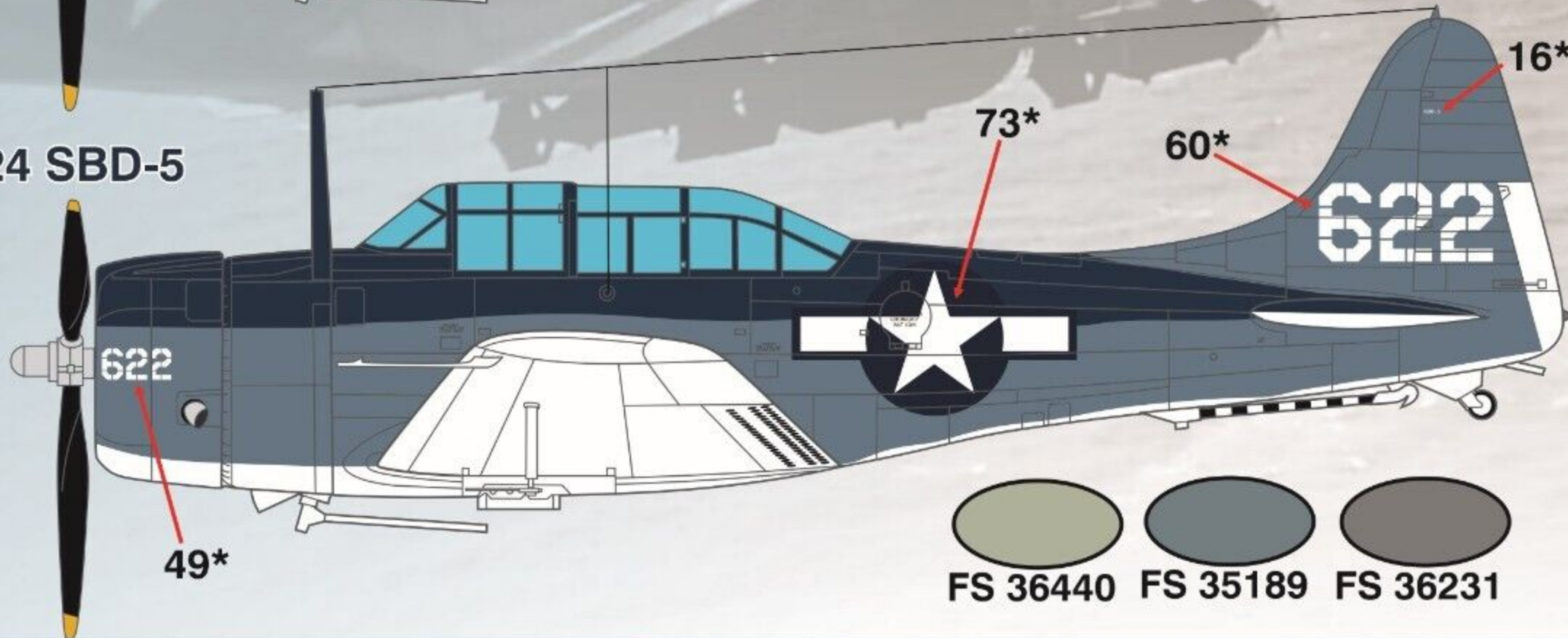

MAG-24 SBD-5
1943

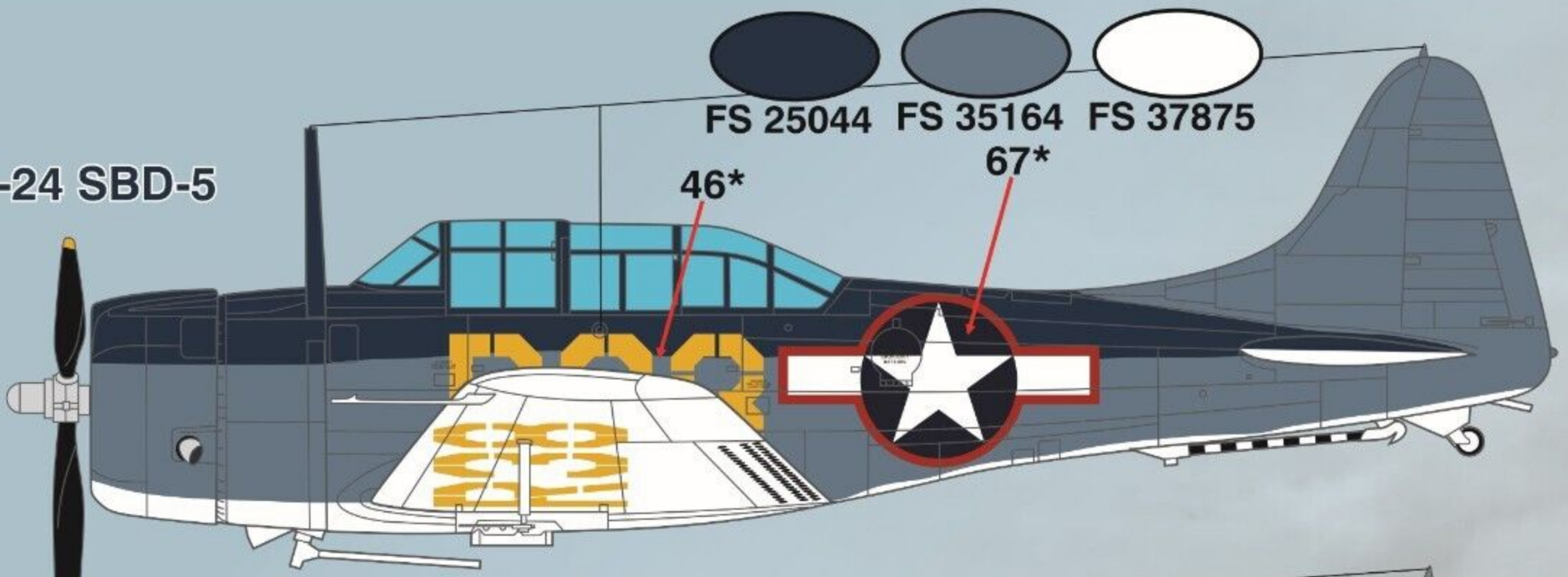

VS-41 SBD-3
USS RANGER
1943

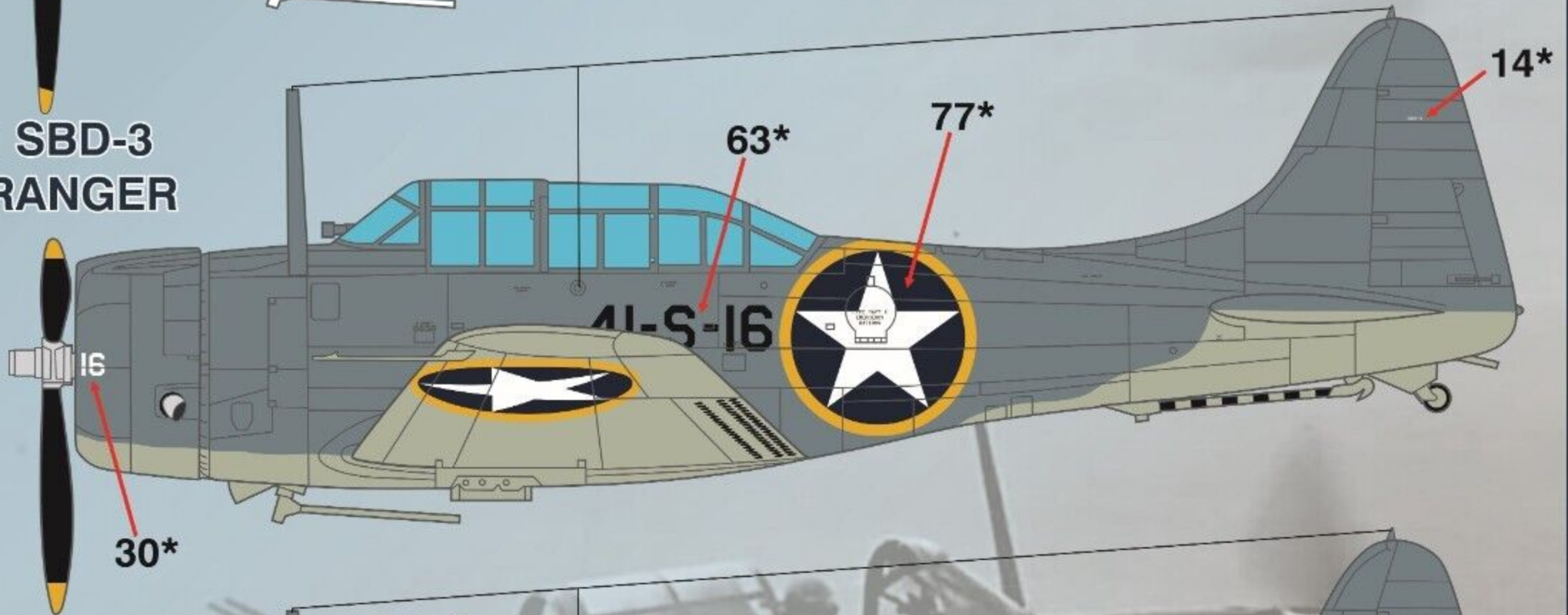

VMSB-144 SBD-4
1943

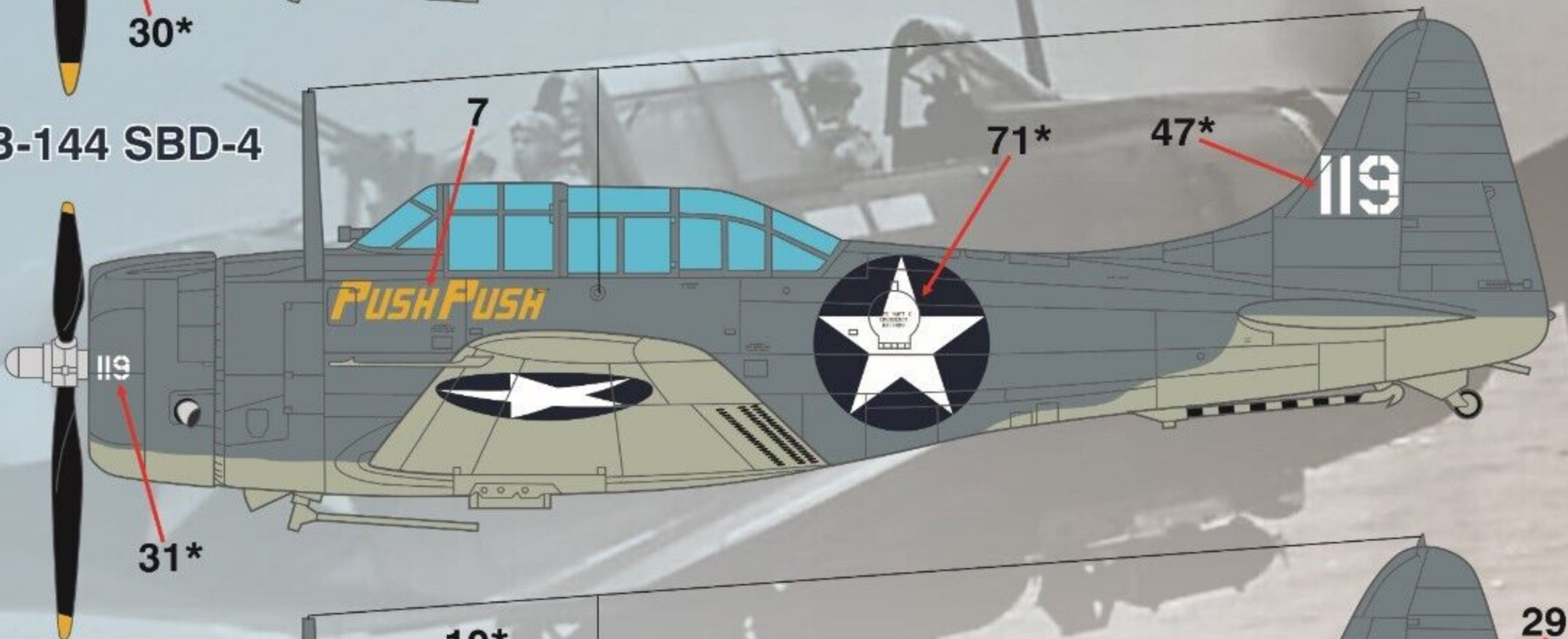

VMSB-233 SBD-4
1943

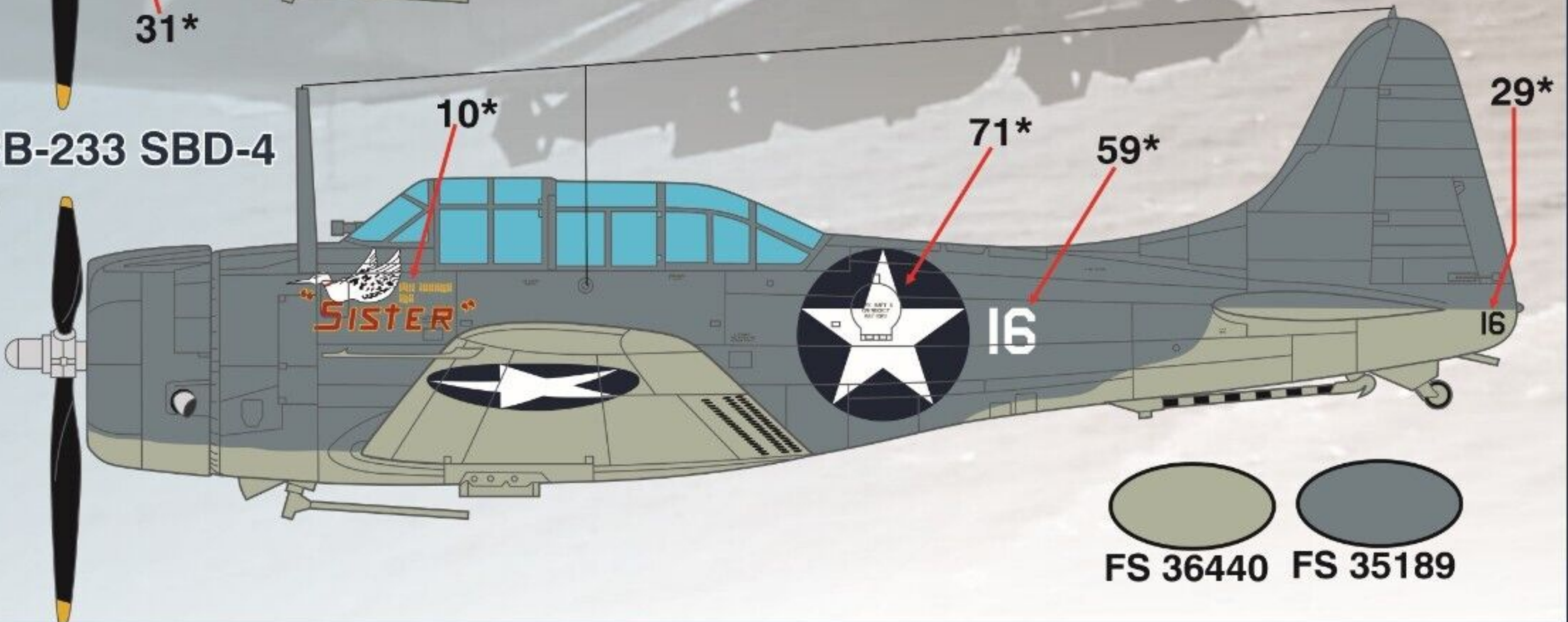

A-24B 42-54298
1943

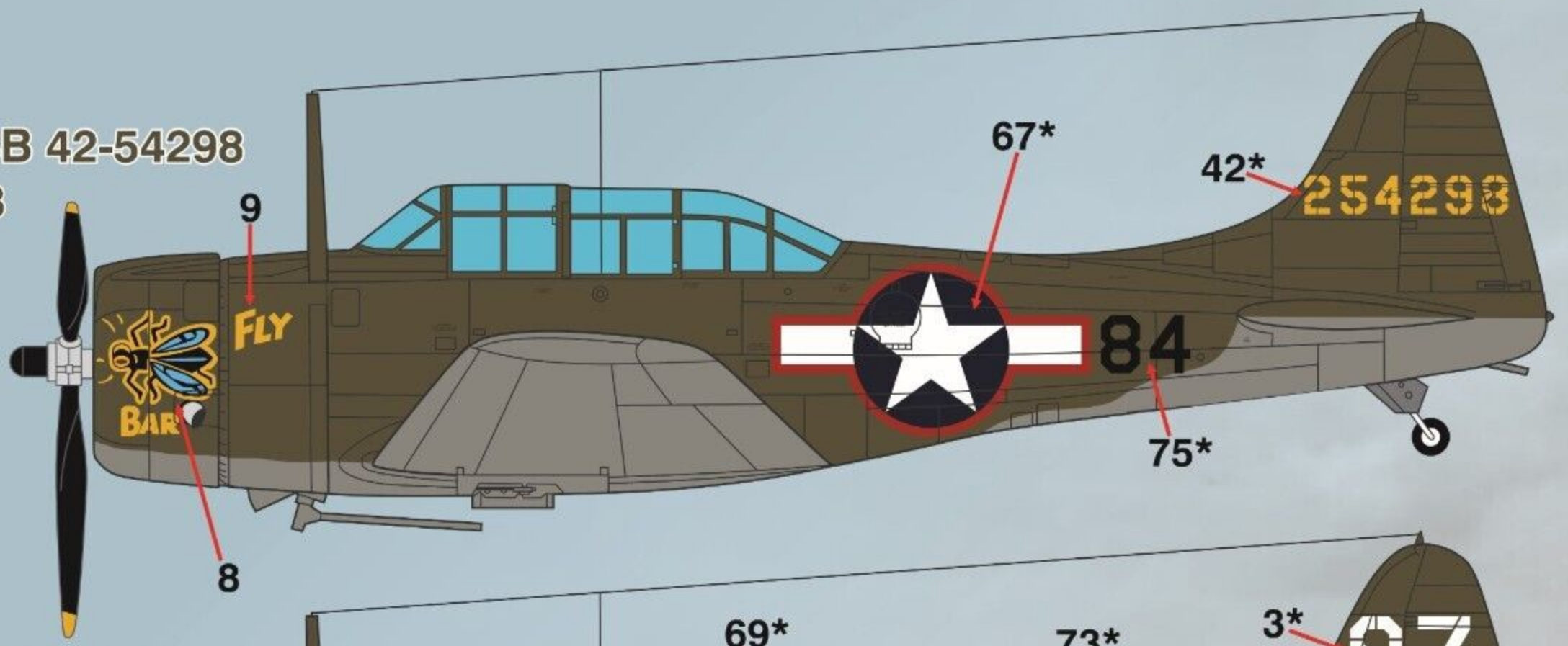

A-24B 42-54897
1945

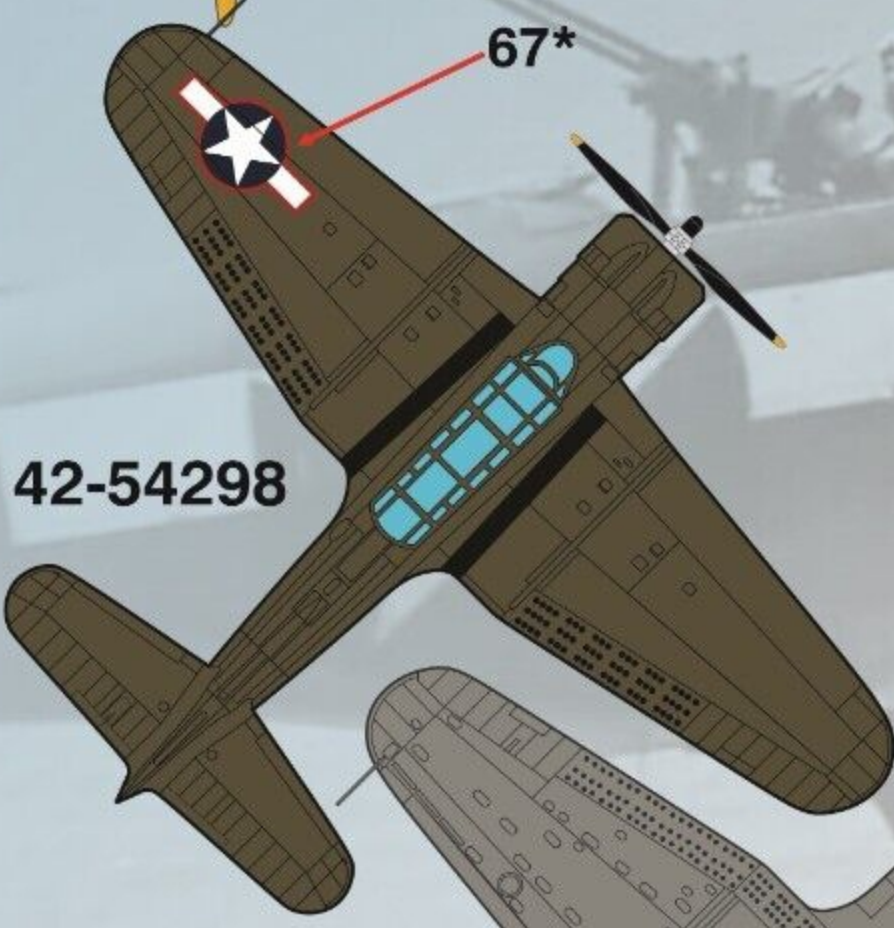
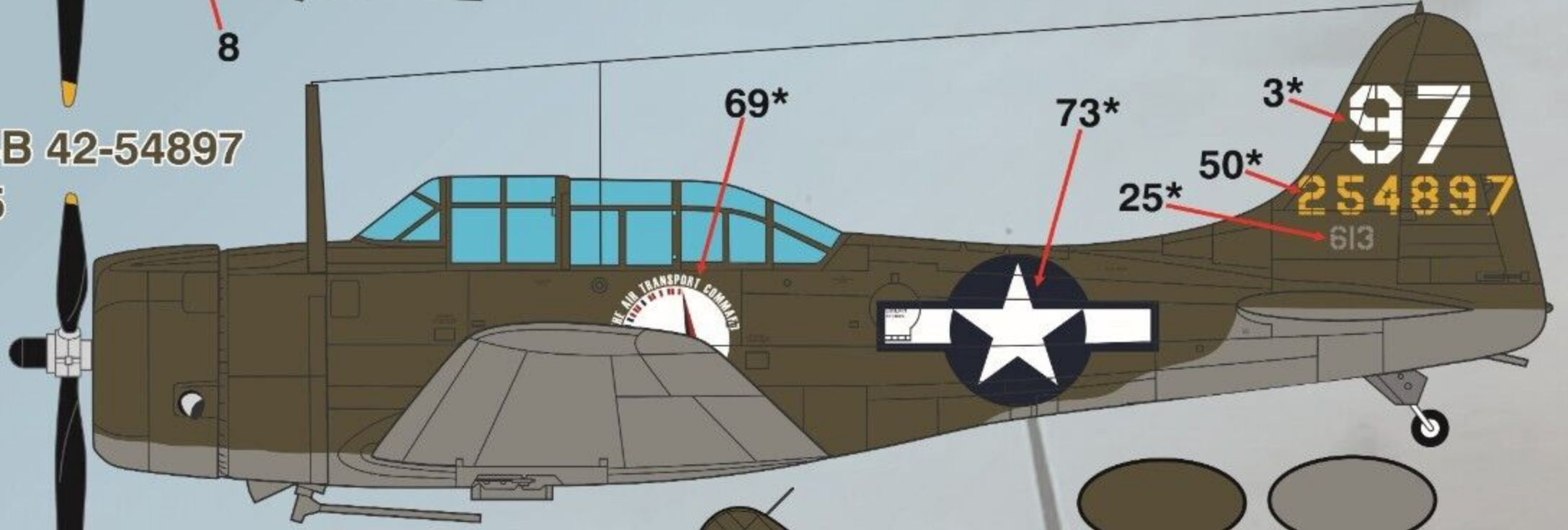

42-54298

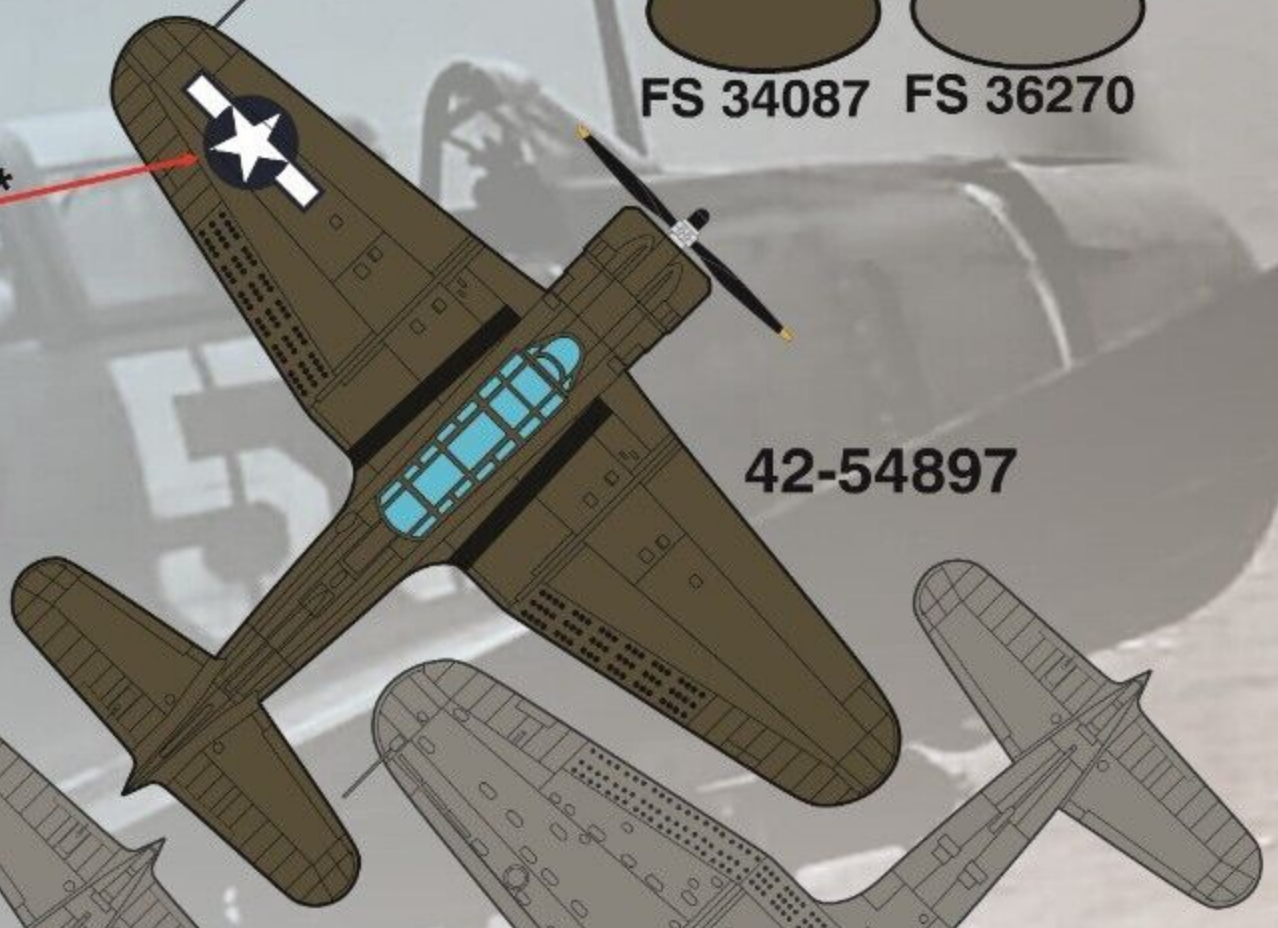

42-54897

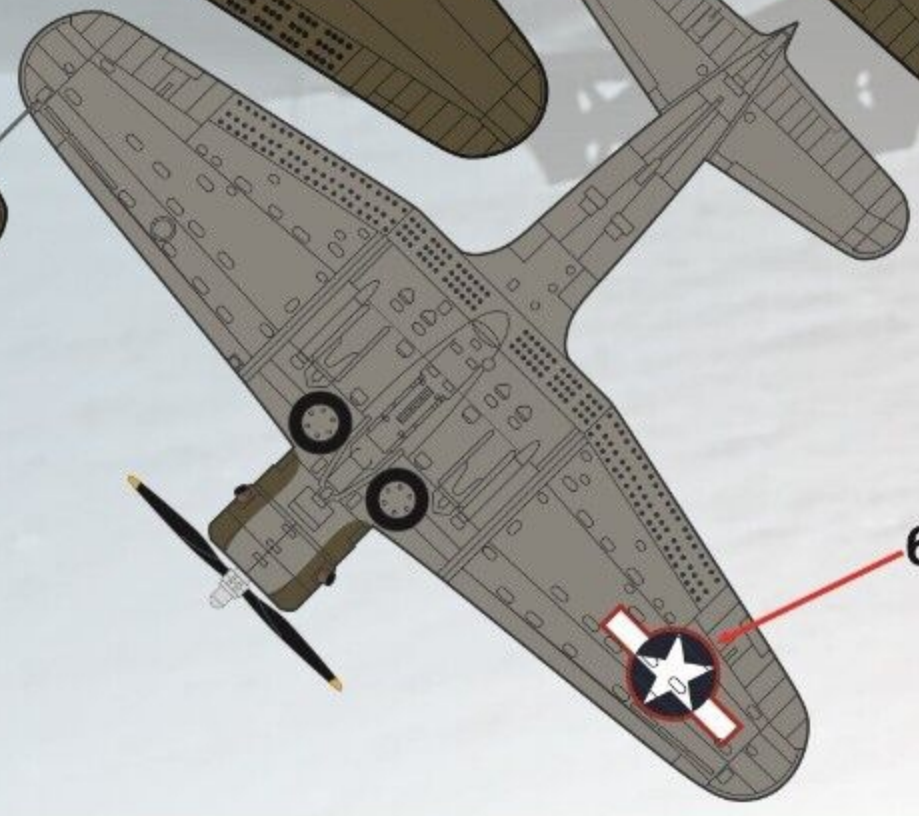

67*

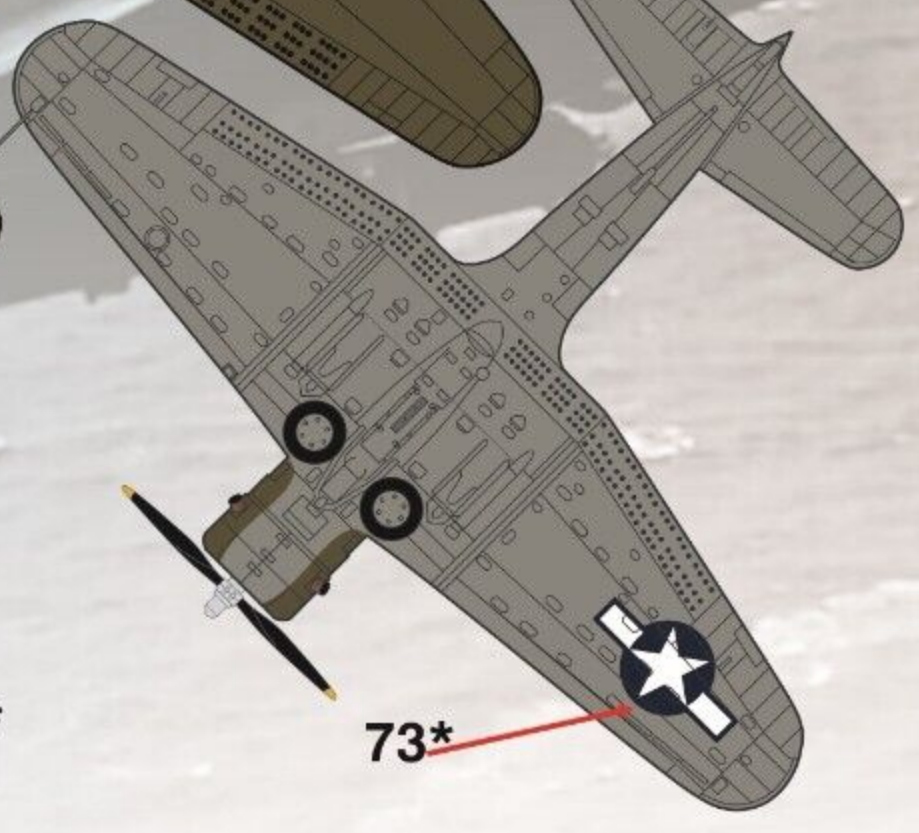

73*

VS-5 SBD-3
"5-S-14"

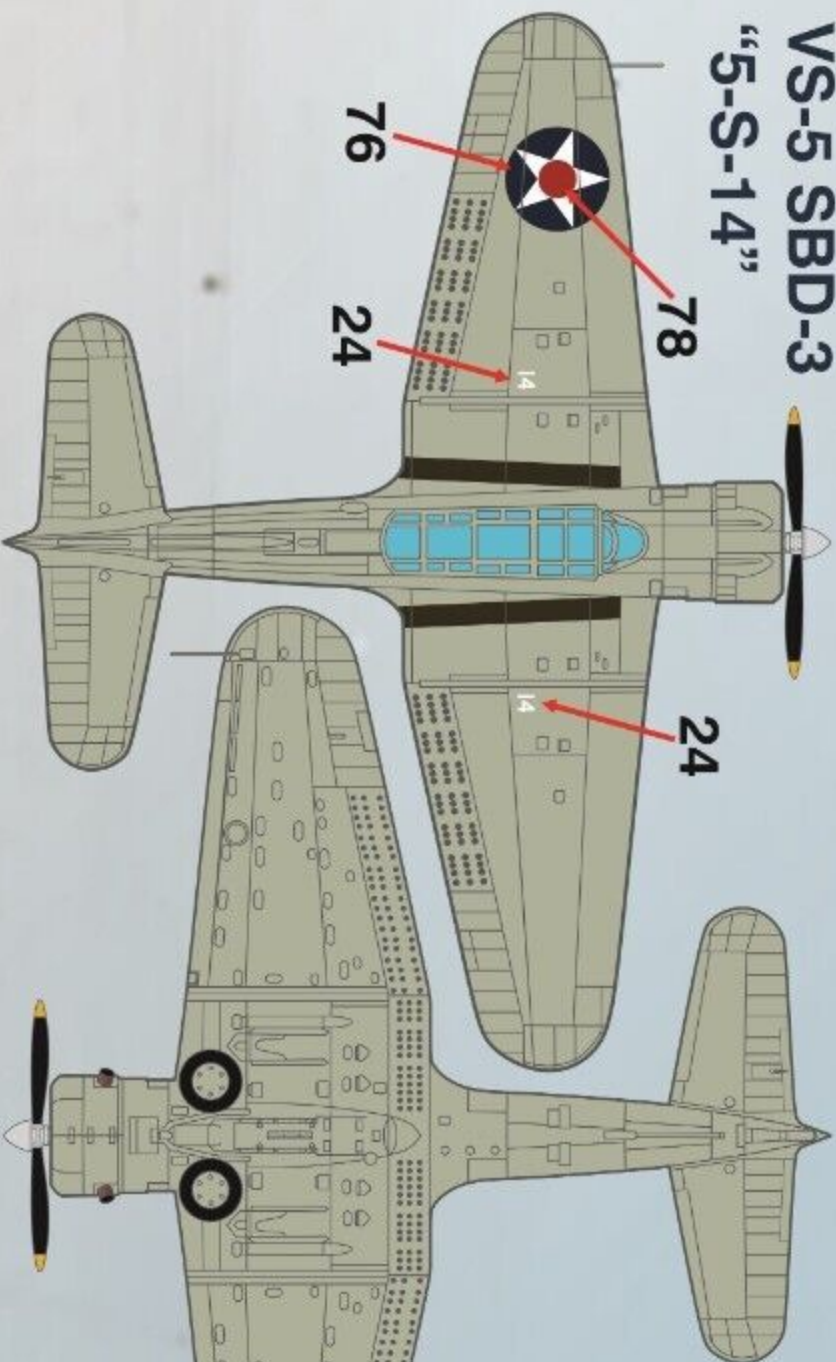

VS-2 SBD-3
"2-S-12"

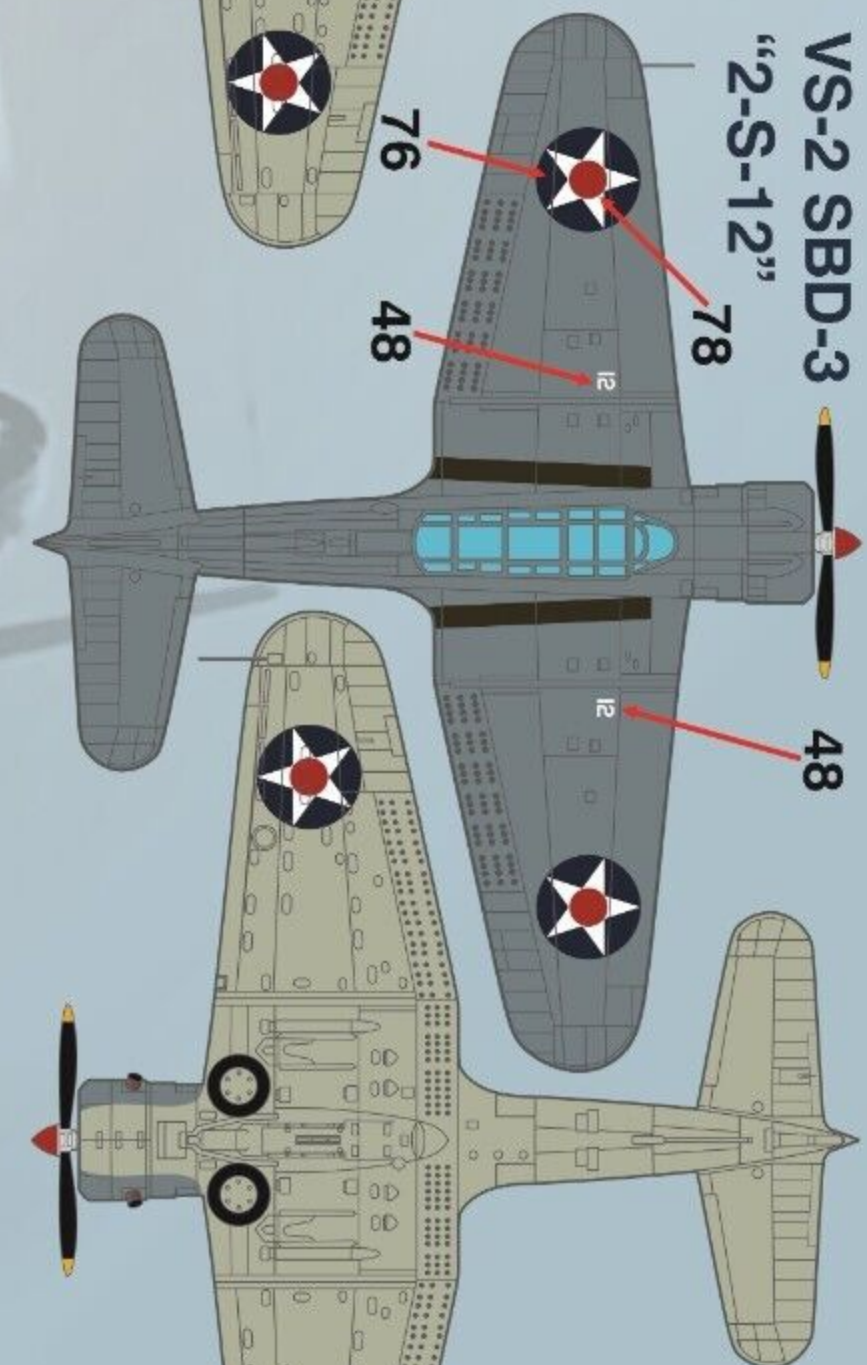

48

78

76

76

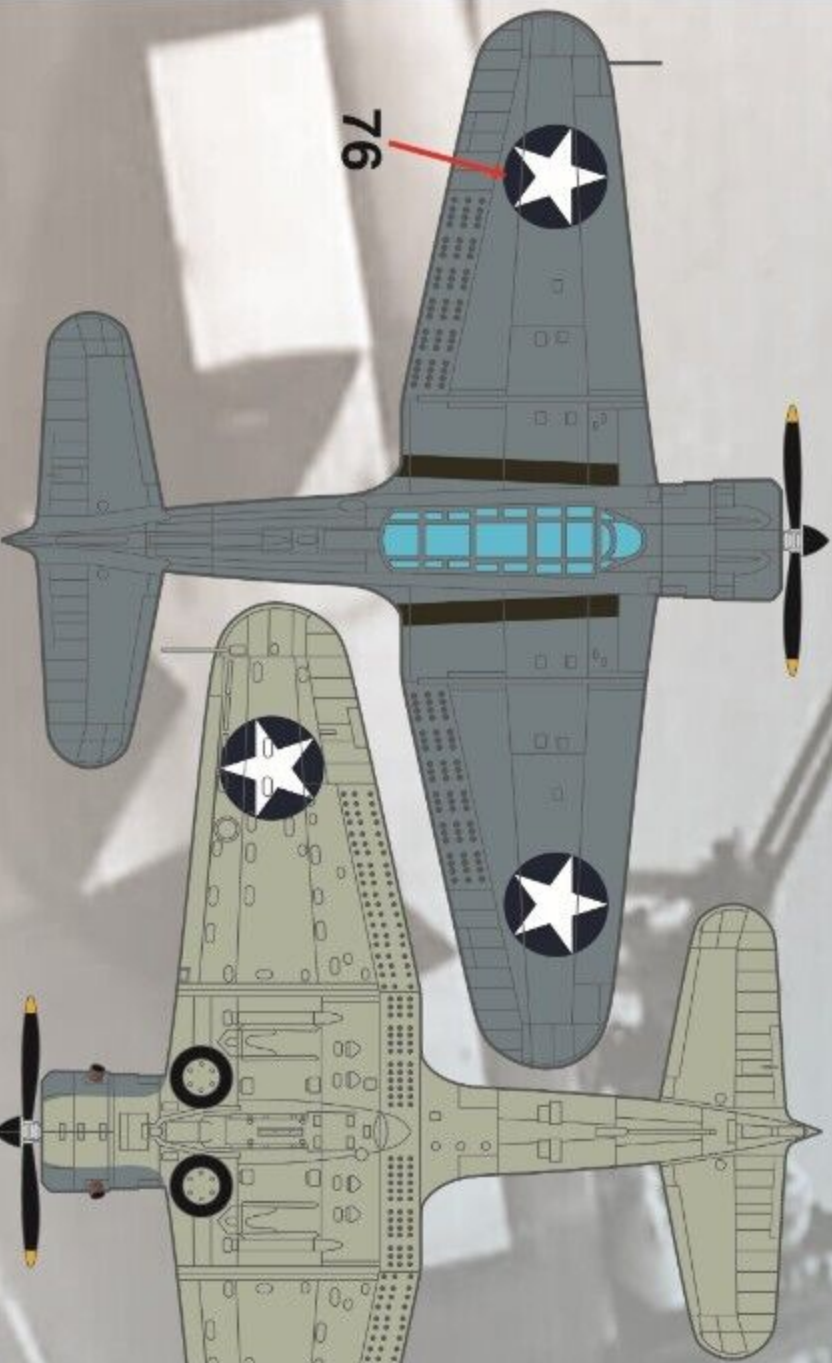

76

74

74

VS-2 SBD-3 "CG" & "B1"

VS-2 SBD-3 "S-10"

VS-64 SBD-5 "10"

VMSB-144 SBD-4 "119"

VMSB-233 SBD-4 "16"



FS 36440 FS 35189



FS 25044 FS 35164 FS 37875



VB-16 SBD-5 "35"

VMSB-231 SBD-5 "2"

MAG-24 SBD-6 "713"

MAG-24 SBD-5 "622"

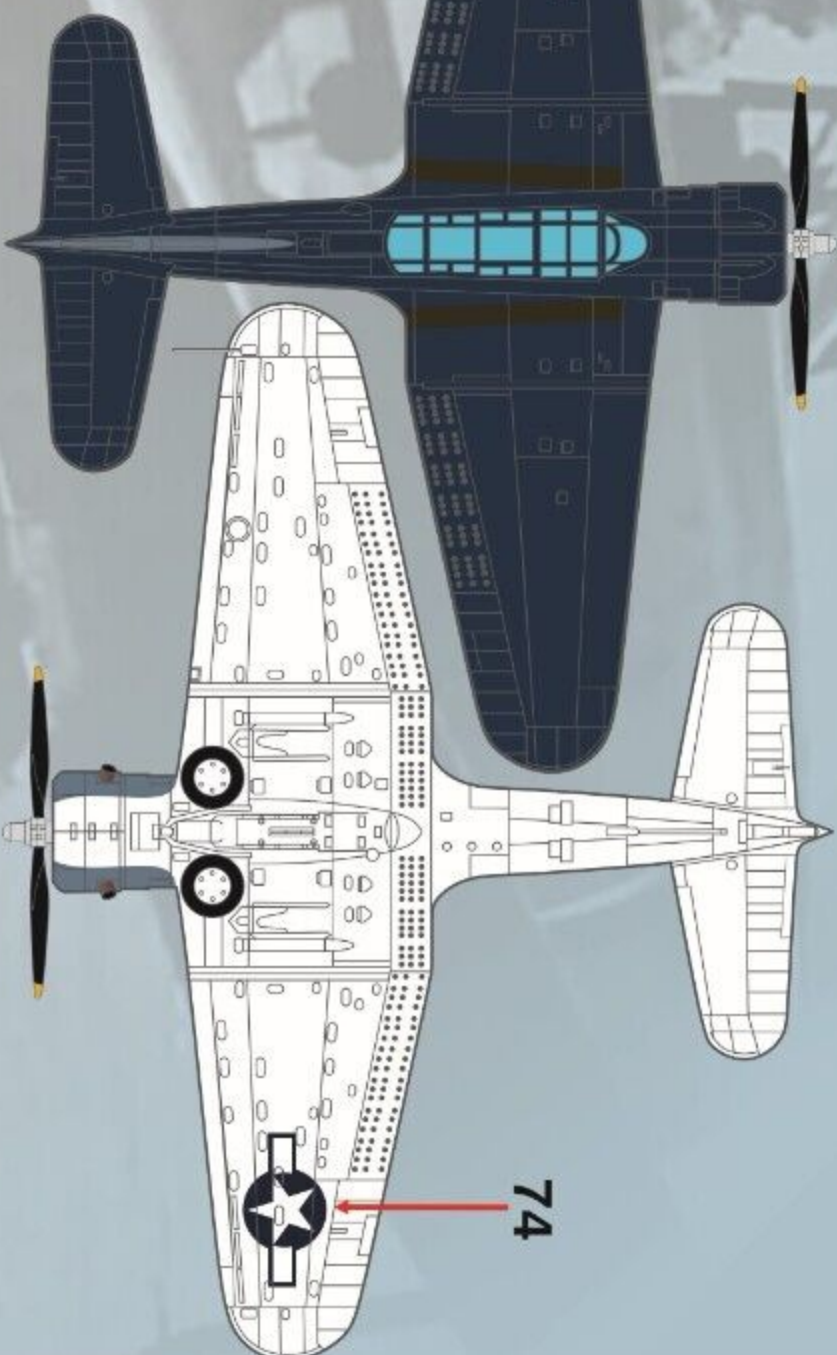

FS 25044 FS 35164 FS 37875

MAG-24 SBD-5 "R38"

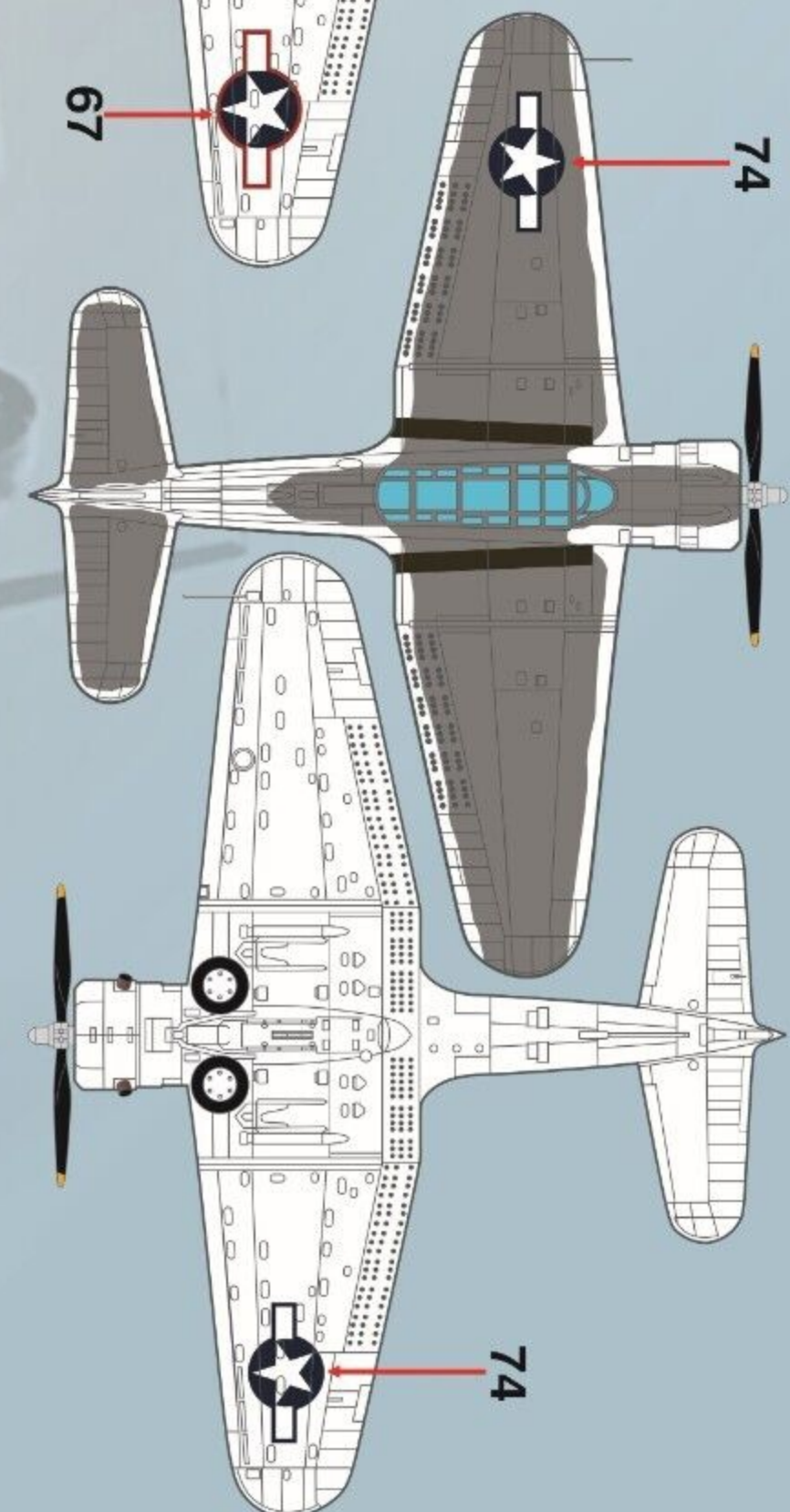
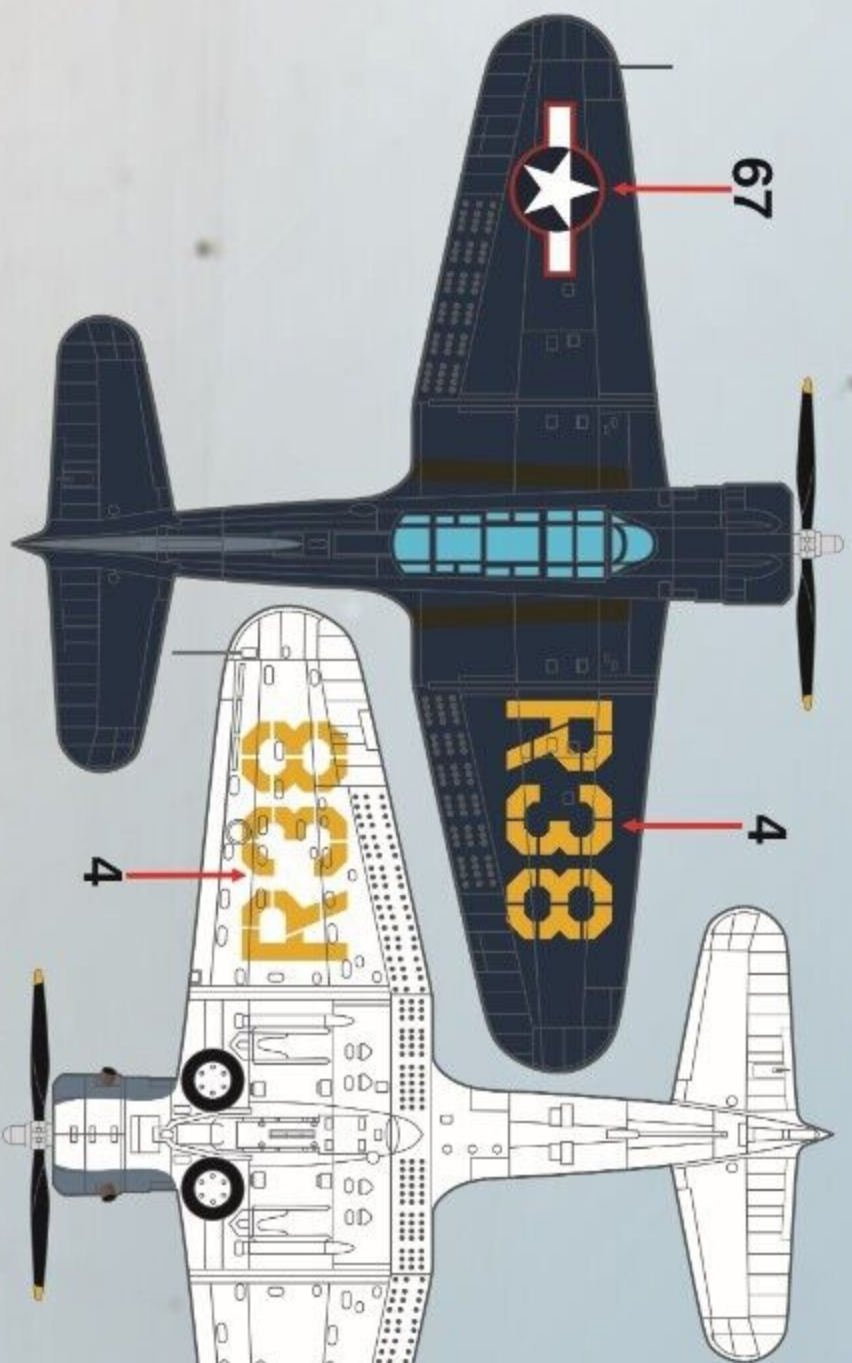

VMS-3 SBD-5 "S-1"

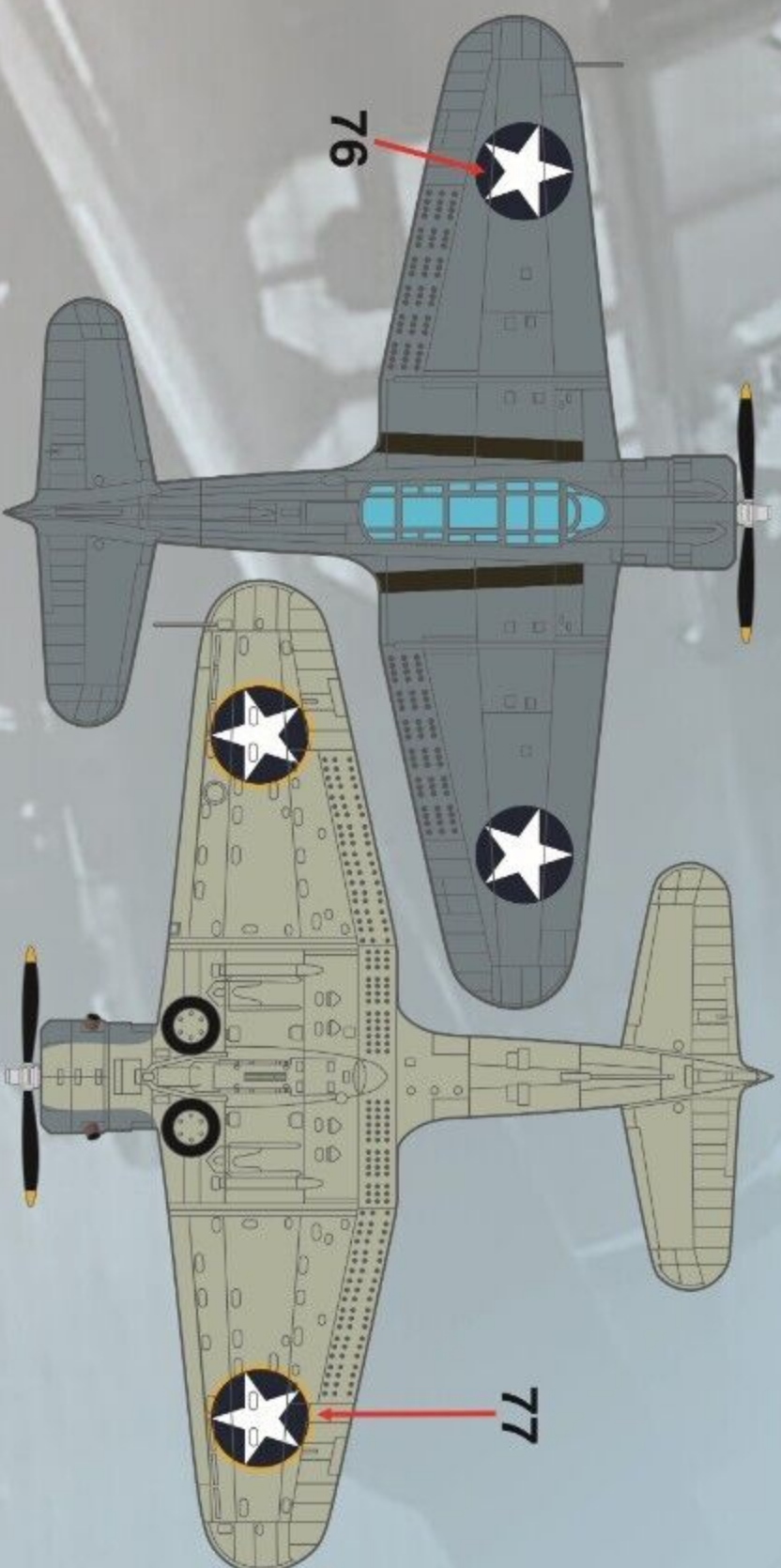

VS-41 SBD-3 "41-S-16"

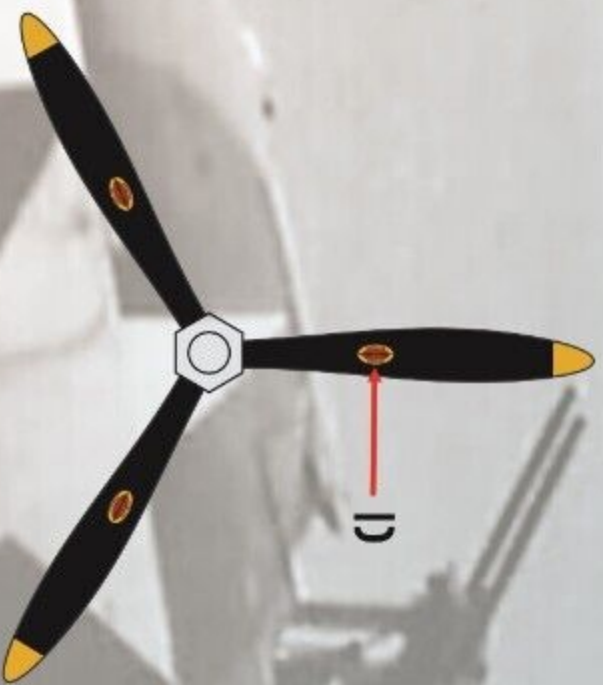

- FS 36440
- FS 35189
- FS 36231
- FS 25044
- FS 35164
- FS 37875

STENCIL PLACEMENT

**Naval aircraft had their bureau numbers painted in 1" numbers in this position on both sides of the tail. Due to their size, bureau number identification is nearly impossible from photos. Specific bureau numbers were included in this set when known. Enough 1" numbers have been included to replicate any bureau number.

