

EagleCals  
EC#148

1/32  1/48  
 1/72

# P-61A

## BLACK WIDOW



**eagle**  
EDITIONS LTD.



“Borrowed Time” P-61A-5-NO 42-5547



“Double Trouble” P-61A-10-NO 42-5565



“Lady Gen” P-61A-5-NO 42-5544



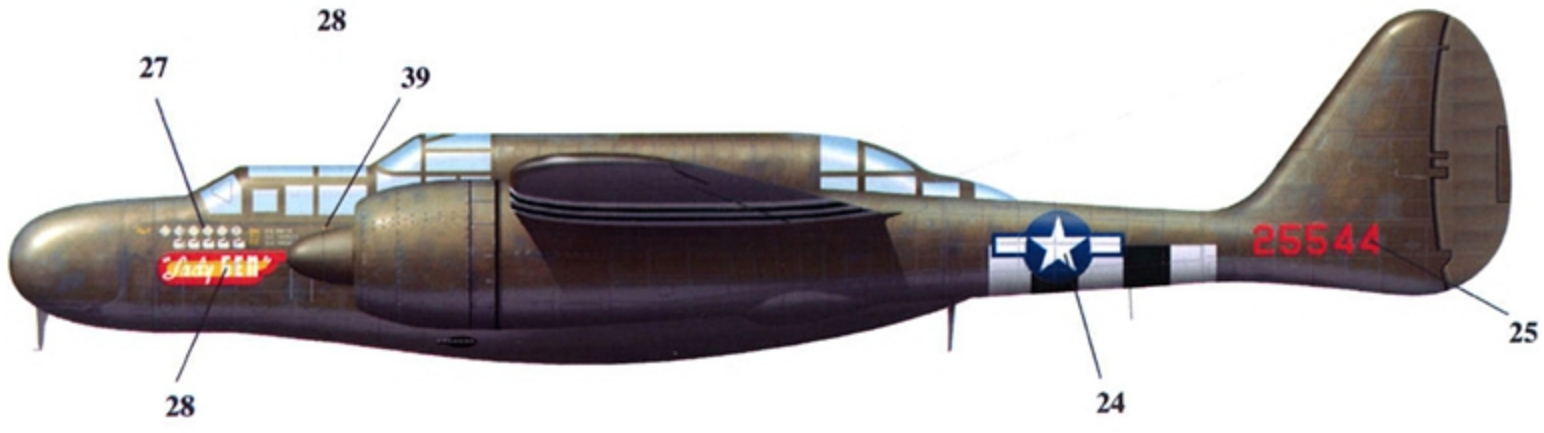
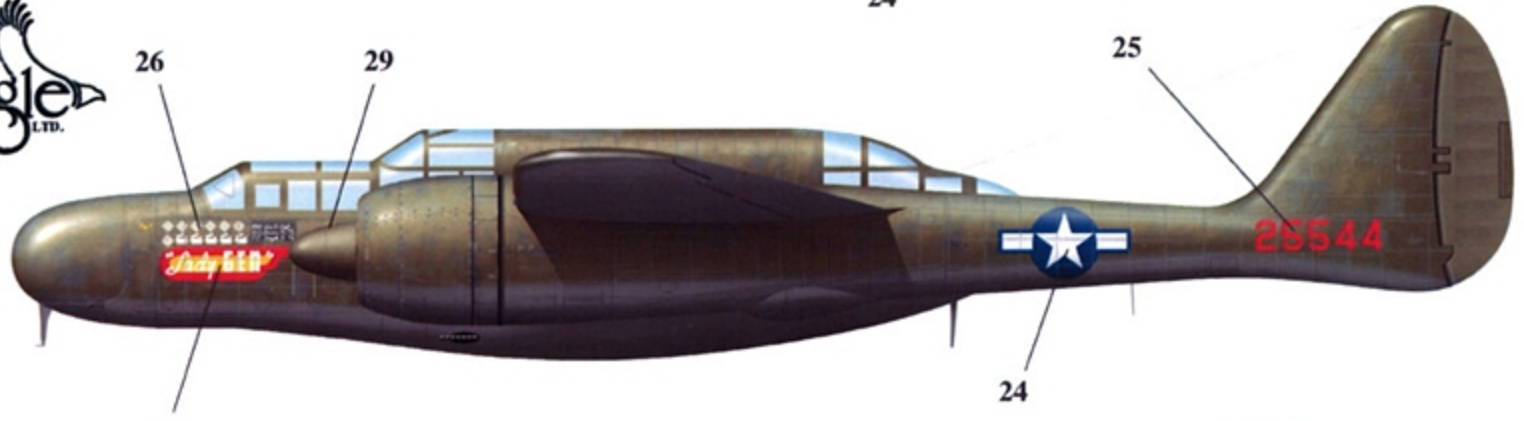
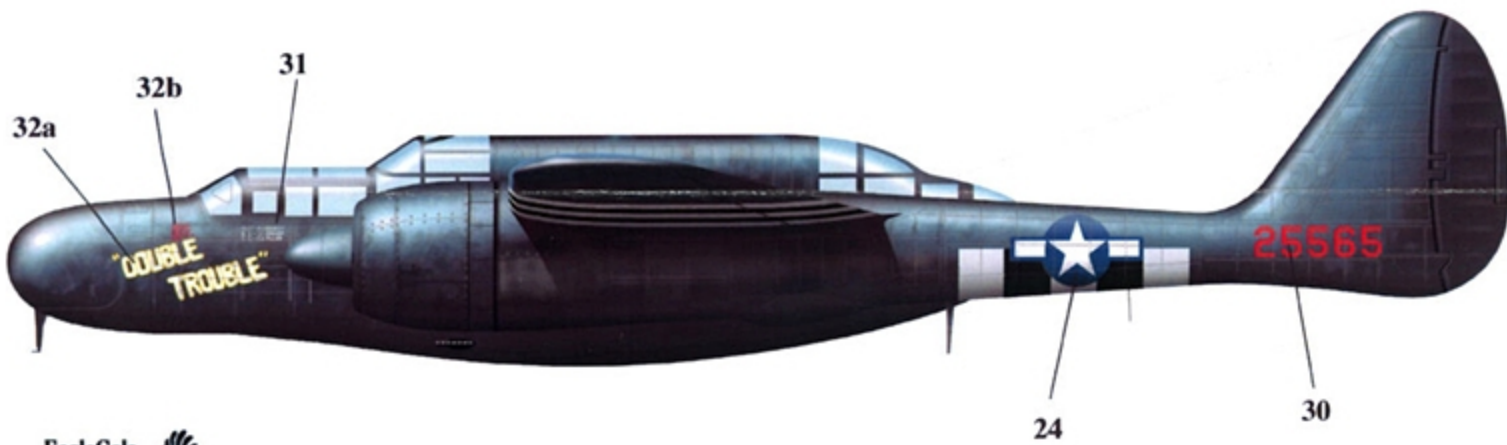
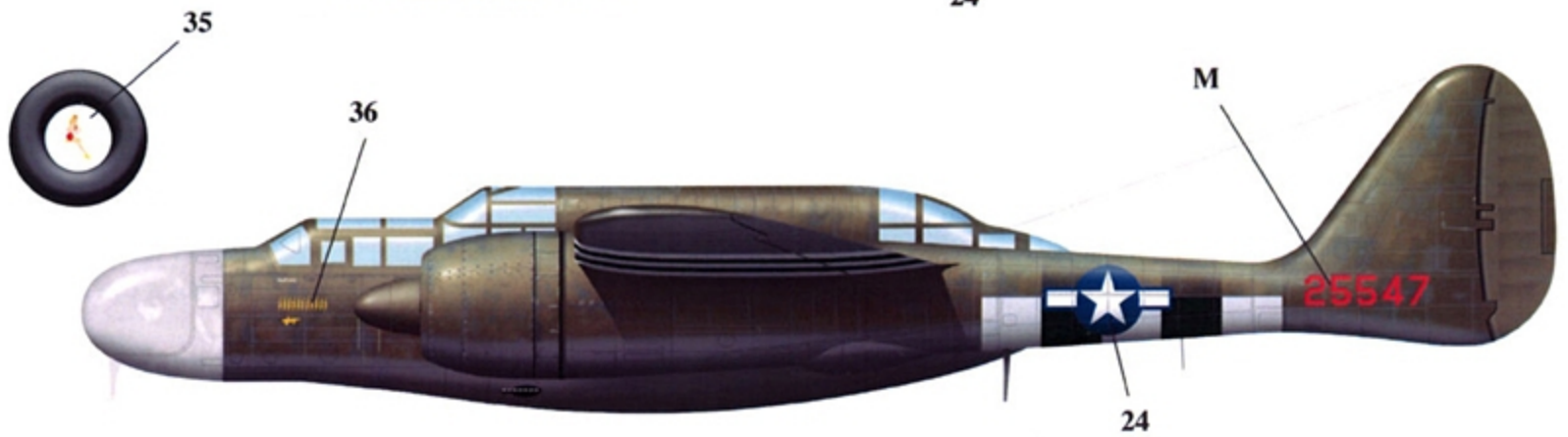
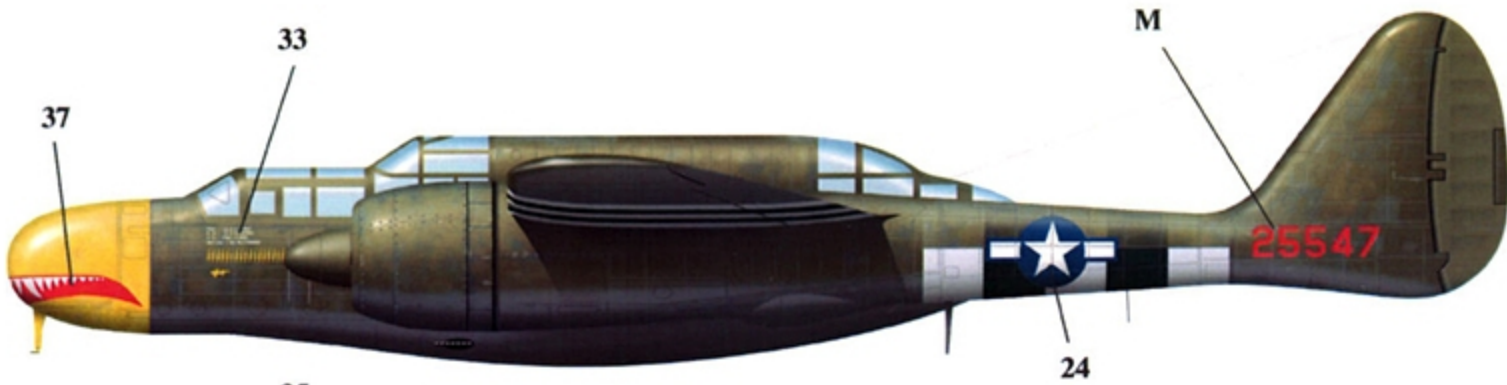



**Borrowed Time**

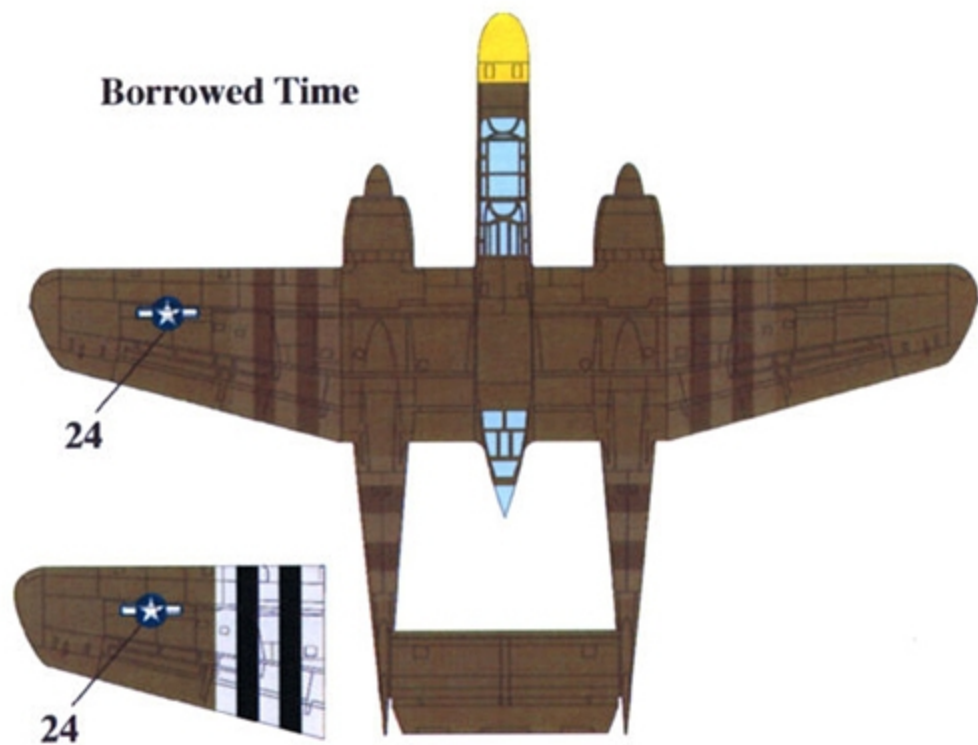

**Double Trouble**

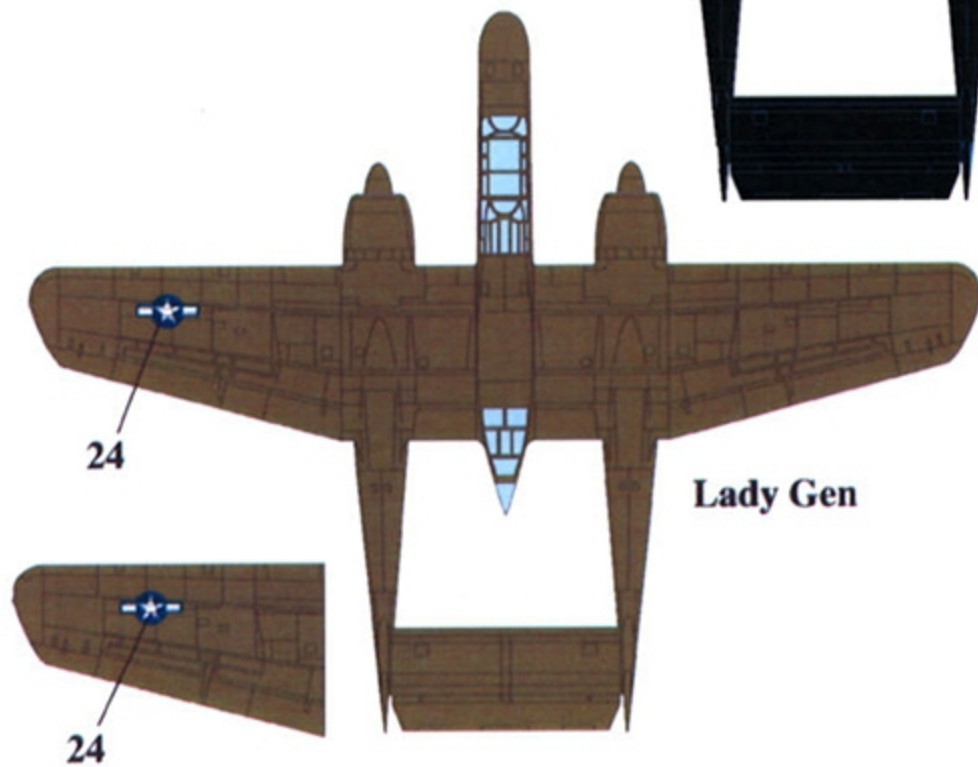
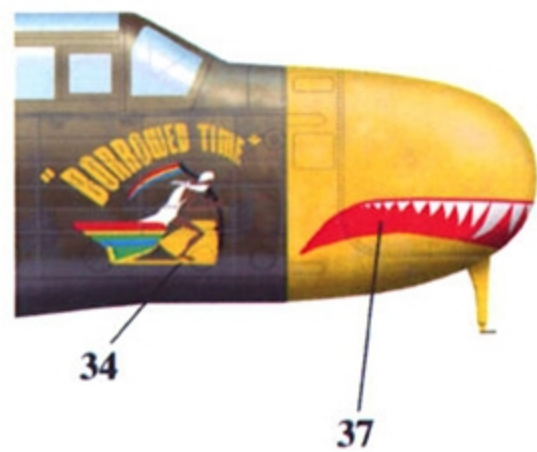
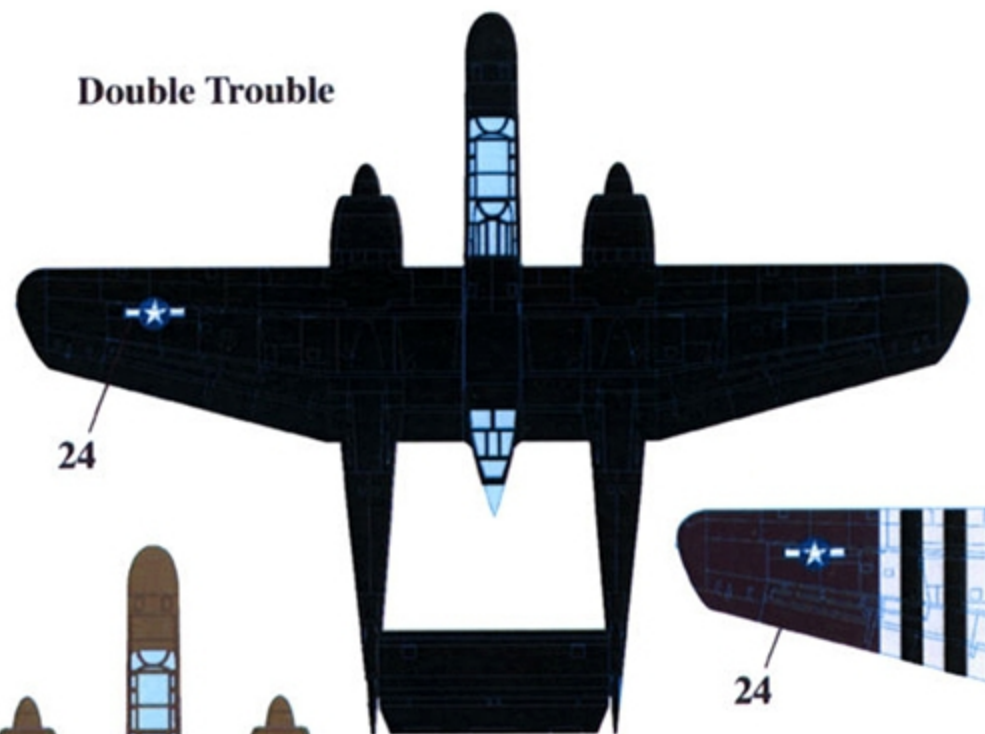

# EagleCals #148

# P-61A Black Widow

In March, 1944 the men of the 422nd NFS departed Florida destined for England. On 23 May 1944, the first P-61 arrived at their base at Scorton. After a period of training in their new nightfighter, the 422nd NFS became operational shortly after D-Day. By the end of hostilities, just under one year later, the 422nd NFS had claimed 43 aircraft and 5 V-1s as destroyed. This decal sheet identifies three of their aircraft.

---

**"Borrowed Time"**      **P-61A-5-NO**      **42-5547**

**Pilot:** 1/Lt. Herman Ernst. Radar Operator: 2/Lt. Eduard "Mouse" Kopsel

This was the first crew to claim a V-1 victory on 15 July 1944, and is also credited with an additional five aerial victories. The aircraft was written off due to a landing incident at Florennes, Belgium in Dec 1944.

**Colors:** Uppersurfaces: Olive Drab. Lowsurfaces: Neutral Grey. Nose: Initially, White radome only; subsequently expanded to entire forward nose White. Later, White changed to Yellow with sharkmouth.

**Invasion Stripes:** In its earliest iteration, with only the radome painted, this aircraft had complete upper and lower surface stripes. Later, with full solid white nose, stripes reduced to lower surfaces only and remained so when the nose changed to Yellow and sharkmouth added.

**National Markings:** Factory standard

---

**"Double Trouble"**      **P-61A-10-NO**      **42-5565**      **July, 1944**

**Pilot:** 2/Lt. Robert Bolinder. Radar Operator: F/O Robert Graham

This crew is credited with the destruction of four aircraft. It was written off due to a landing incident at Liege, Belgium in April, 1945.

**Colors:** Overall: Gloss Black

**Invasion Stripes:** Lower surfaces only

**National Markings:** Factory standard

---

**"Lady Gen"**      **P-61A-5-NO**      **42-5544**

**Original crew - Pilot:** 1/Lt. Paul Smith. Radar Operator: 1/Lt. Robert Tierney.

**Later crew - Pilot:** Capt. Eugene Lee. Radar Operator: Lt. Alfred Dorner.

Smith gained four of his five victories flying this aircraft. It was lost in a landing accident and destroyed at Kassel, Germany in immediate post war period.

**Colors:** Uppersurfaces: Olive Drab. Lowsurfaces: Neutral Grey.

**Invasion Stripes:** Provisional, the photos are inconclusive if the stripes remained on this aircraft at the time of the crash. In its earlier markings, when piloted by Paul Smith, invasion marking lower surfaces only.

**National Markings:** Factory standard.

---

*Research and project development by Mark Proulx*

© 2013 Eagle Editions Ltd. All images/photos copyrighted by Eagle Editions Ltd. LLC

P.O. Box 580 Hamilton MT 59840

[www.eagle-editions.com](http://www.eagle-editions.com)

No copies may be reproduced without written consent from publisher Eagle Editions Ltd. LLC  
The color schemes depicted are the artist's interpretations of the available photographic references only.  
The final decision resides with the modeler.



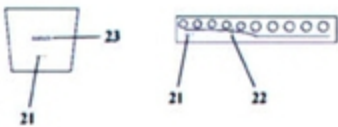
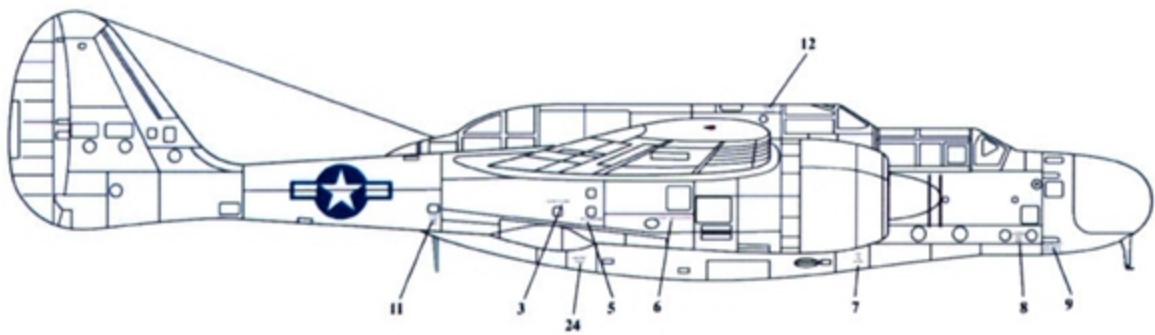
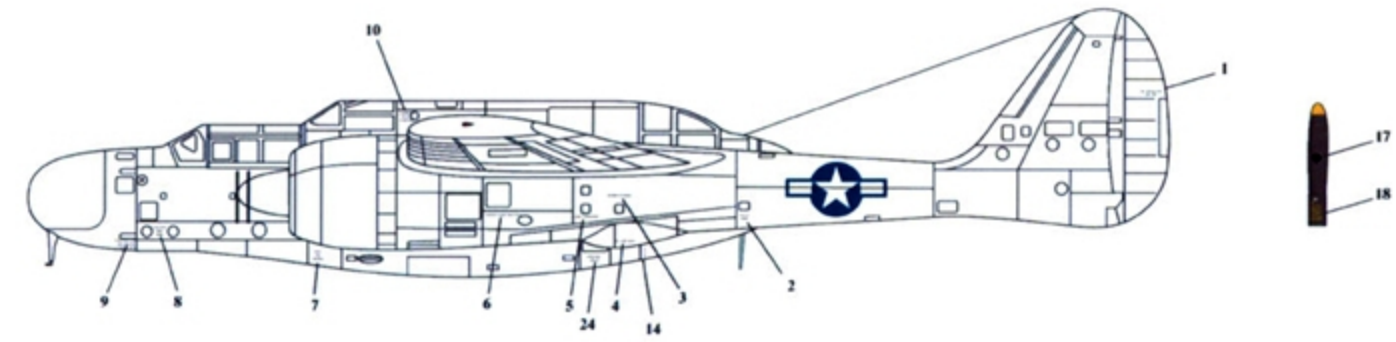
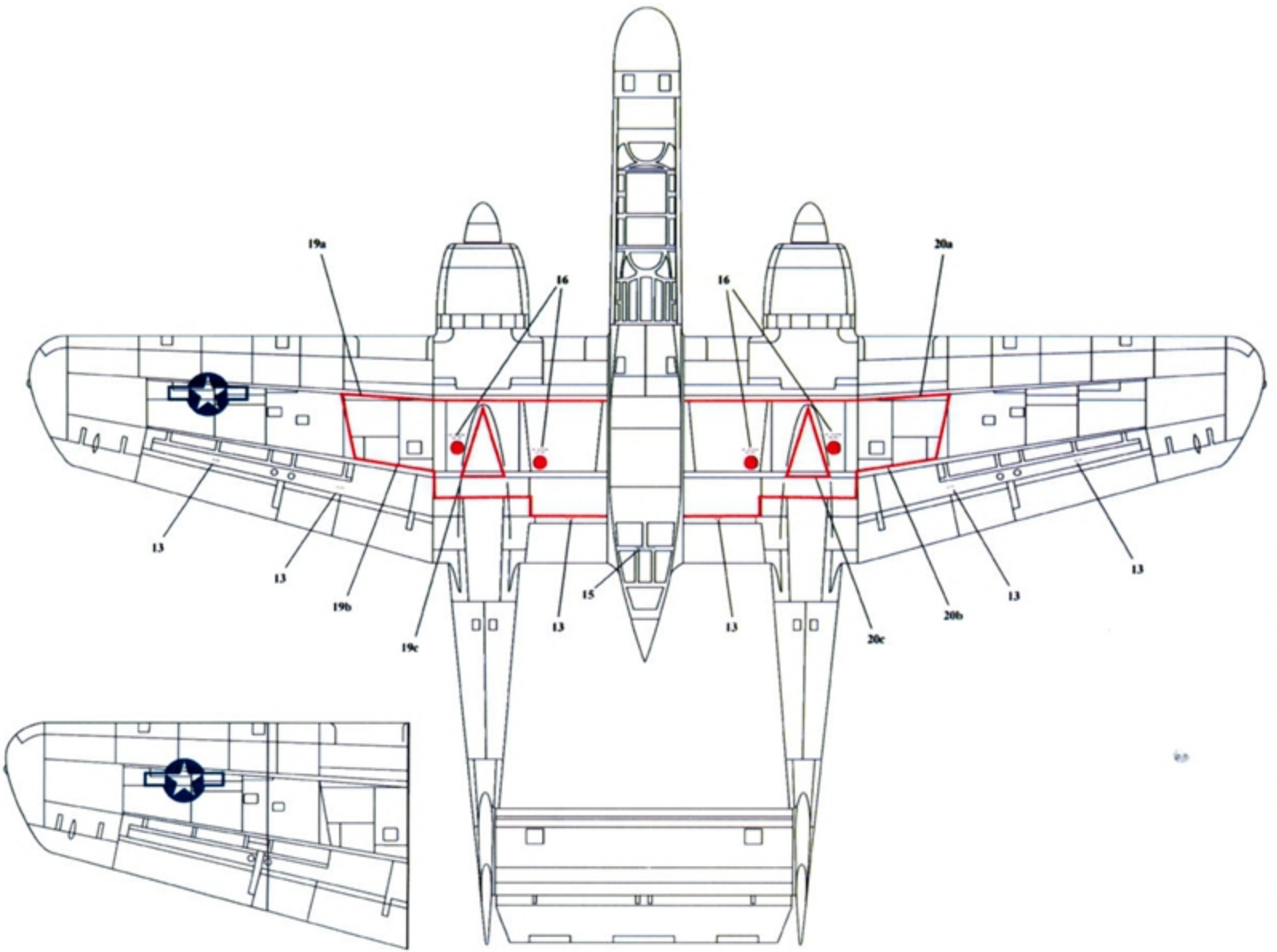

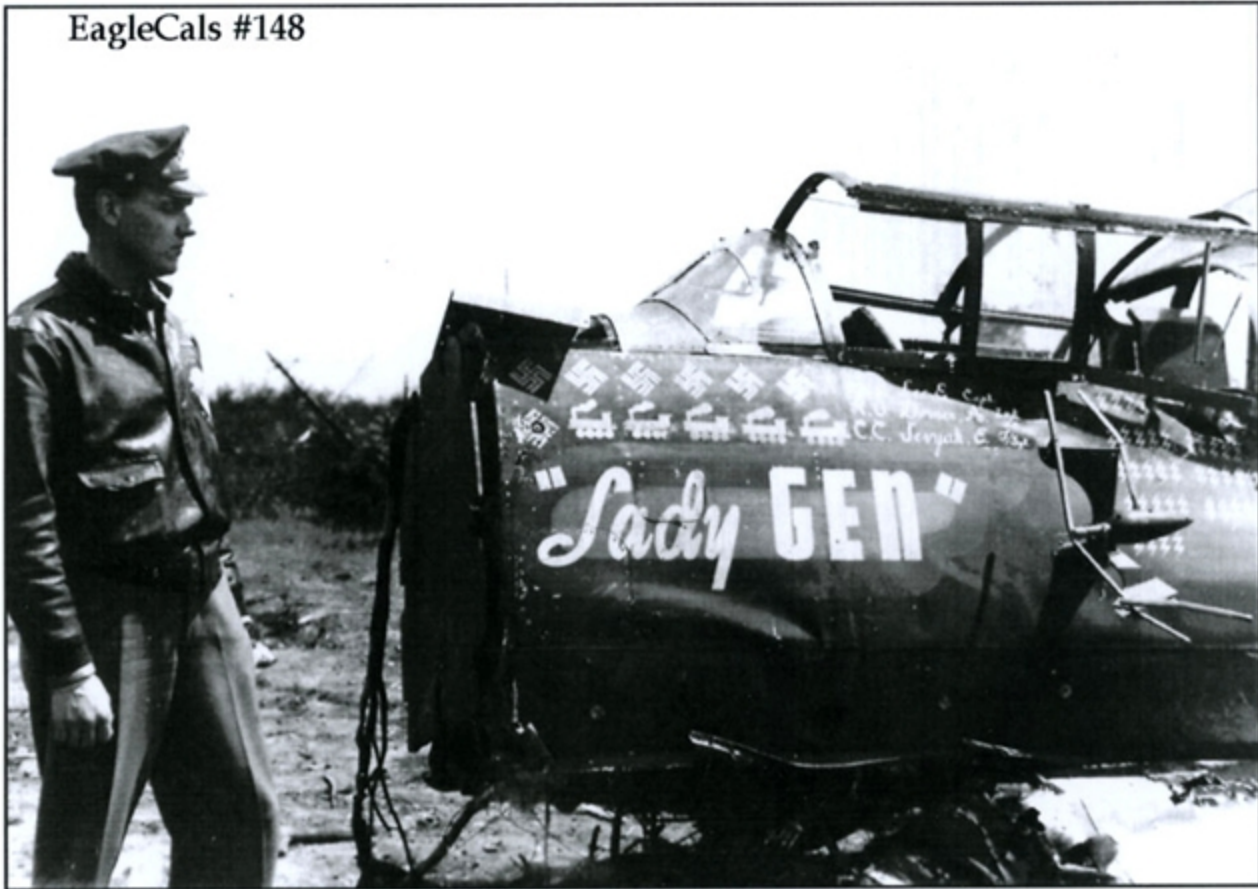

Lady Gen photographed here after crash landing at Kassel, Germany in 1945. The darkened nature of the photo has led many to believe the aircraft was finished Gloss Black. However, close examination of the nose reveals scratches in the same shape and location as the earlier OD/NG finish. Also, the artwork applied to the forward fuselage remains in the exact same location throughout its service career.



Many profiles created of Double Trouble depict the name on the forward fuselage as a single solid color. In this image, the lettering can be seen to have a thin outline applied.