

[AirDOC]

Aircraft Documentations

**British Phantoms - Stencils for the Tactical grey/green
and all grey Air Defence Camouflages**



ADS 173/149001
British Phantoms - Stencils

*some aircraft featured yellow stencil (decal 185a). Check your reference carefully.



(repeat inside pylon)

(repeat inside pylon)

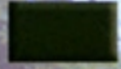

Dark Green
BS 381C.641



Dark Sea Grey
BS 381C.638

Light Aircraft Grey
BS 381C.627

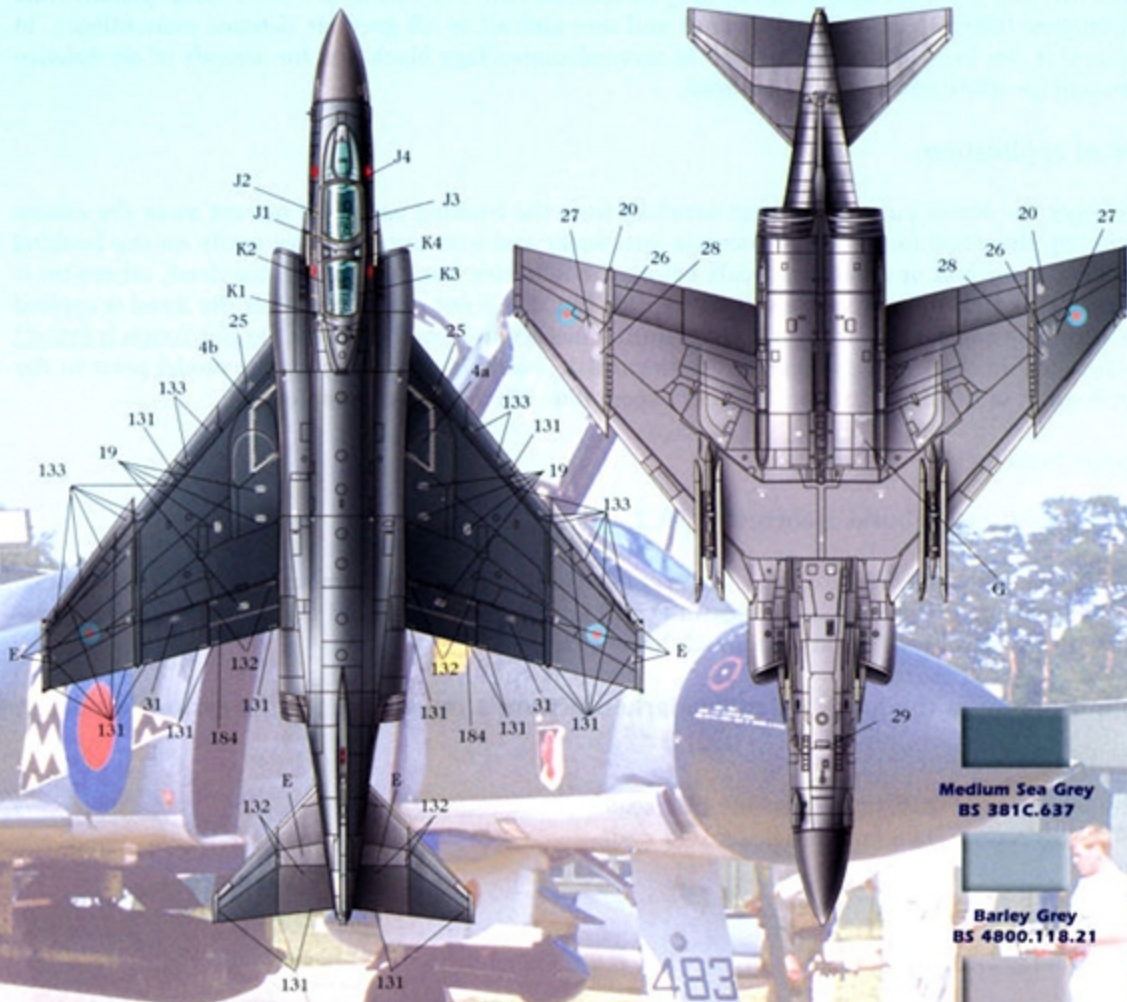

Medium Sea Grey
BS 381C.637

Barley Grey
BS 4800.118.21

Light Aircraft Grey
BS 381C.627

*some aircraft featured a white background behind the red warning triangles. Use decal E1 if you intend to build such an aircraft

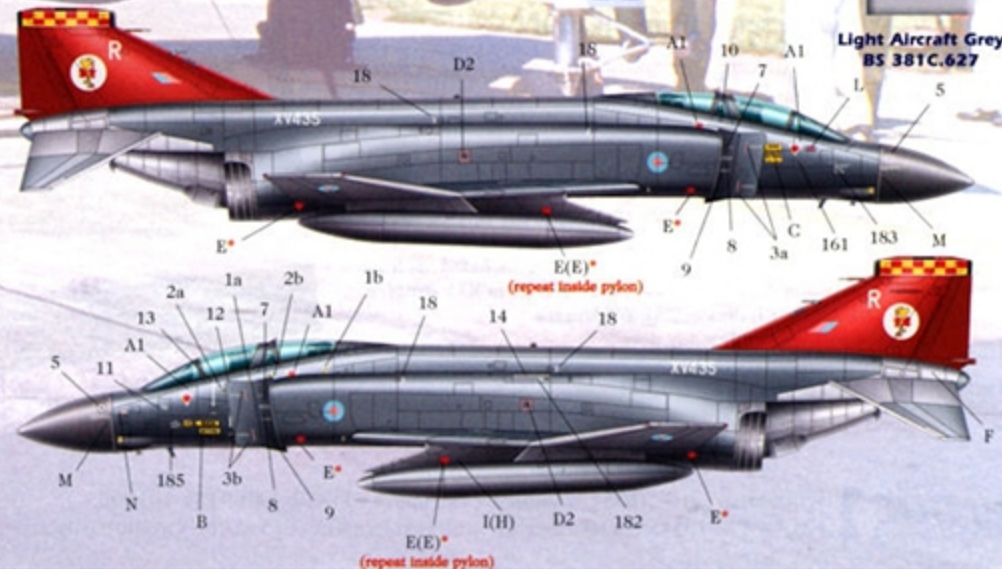

(repeat inside pylon)

(repeat inside pylon)

ADS 173/149001
British Phantoms
stencil application instructions

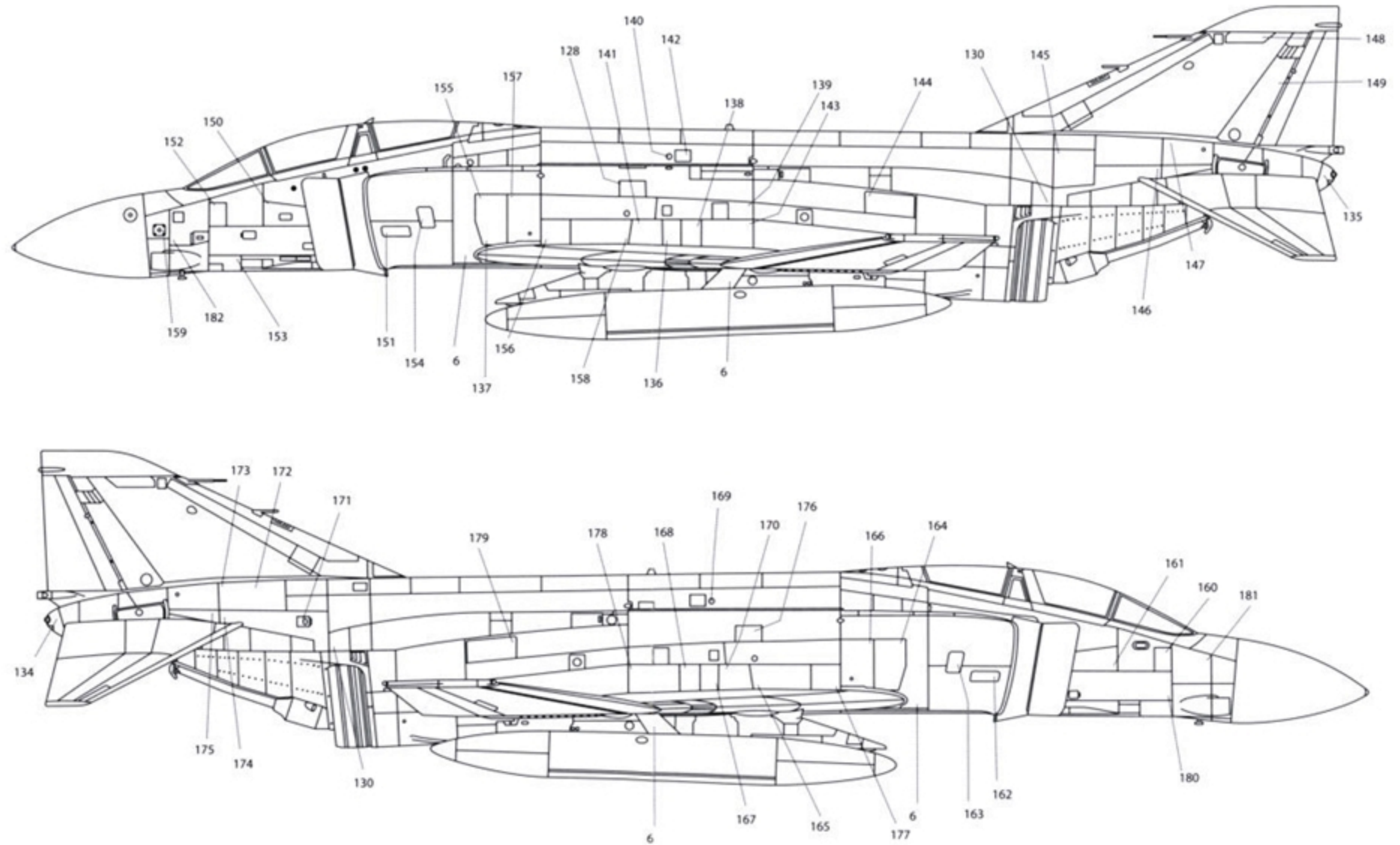

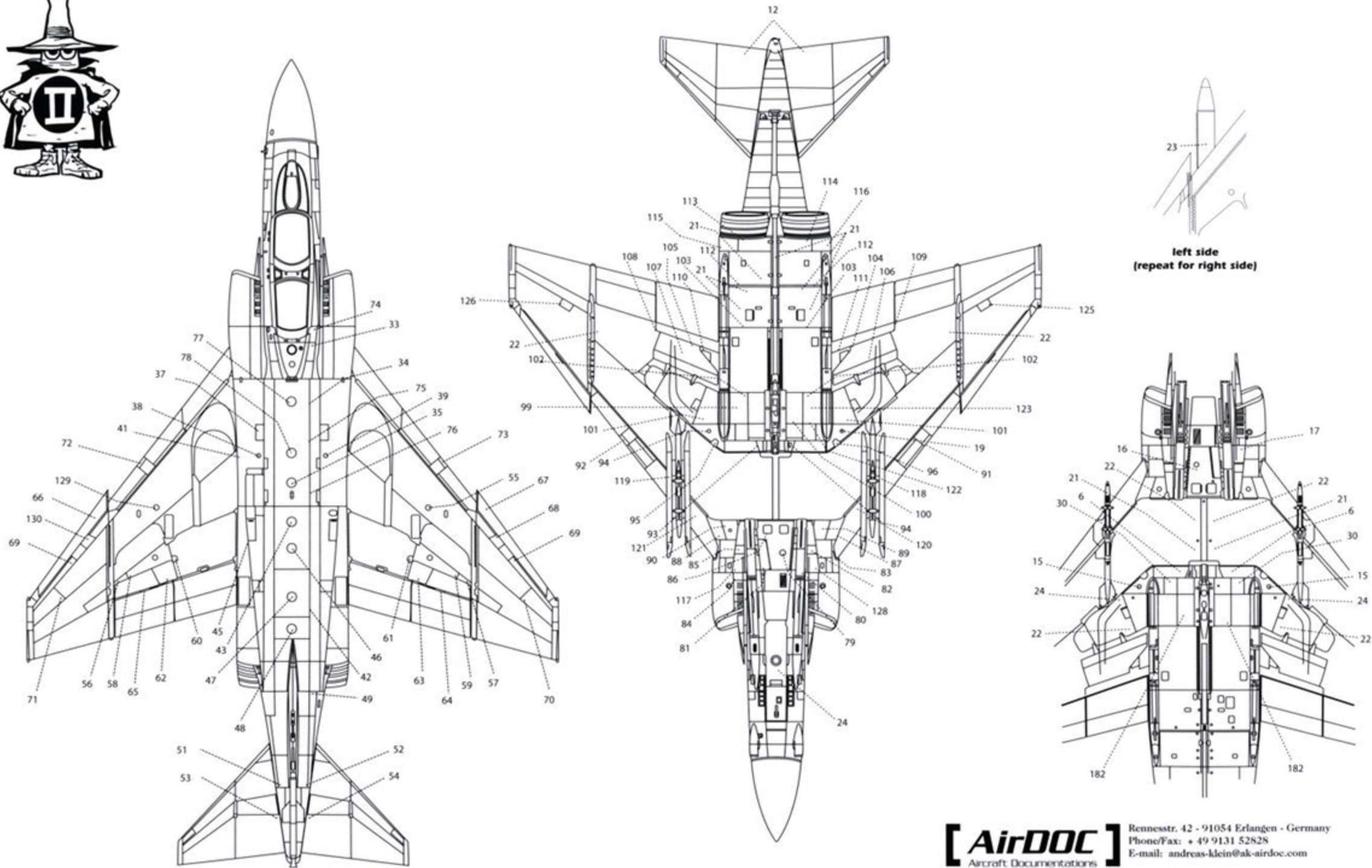

Copyright©2005

[AirDOC] Rennestr. 42 · 91054 Erlangen · Germany
Aircraft Documentations Phone/Fax: + 49 9131 52828
E-mail: andreas-klein@ak-airdoc.com

ADS 173/149001
British Phantoms
stencil application instructions

Instructions

This AirDOC decal set allows you to fully fit out two RAF F-4 Phantom FGR.2 with stencils (one green/grey tactical camouflaged aircraft and one aircraft in all grey air defence camouflage). In general it can be said that for aircraft in tactical camouflage black and for aircraft in air defence camouflage white stencils must be used.

Decal application:

To apply the decals cut each subject carefully from the backing paper. Do not cut away the excess film. Dip the decal for about 20 seconds into water and wait until it slides easily on the backing paper. Do not pull or push the decals before the adhesive has completely dissolved, otherwise it might be ruined. You may use a setting solution but this is not necessary. After the decal is applied to the model's surface, wait several hours until it has set and dried properly. Do Not Touch It Prior!! Depending on the surface's quality, a gloss varnish should be sprayed onto the model prior to the application of the decals, thus, the clear excess film will disappear completely.

Happy Decaling!

Kit suggestions to build a correct FGR.2

1. 1/72 scale modelers try to obtain the very good Fujimi FGR.2 kit number H-6, 7, 8, 9 and others.
2. 1/48 scale modelers use the Hasegawa FGR.2 kit PT 16 or the Revell FGR.2 kit no. 04588 (a re-issue of Hasegawa's PT 16 kit at a much lower price).

In our opinion the following after market kits are a must have for the serious modeler:

True Details:

72009 US Navy F-4J/S bulged wheels 1/72 scale.

48051 US Navy F-4J/S bulged wheels 1/48 scale

Aires:

04123 1/48 F-4 wheel bays

Black Box:

48071 F-4J/FGR.2 cockpit set

For further reference see our publication:

AirDOC Post WWII Combat Aircraft No. 5 British PHANTOMS - The FGR.2 of the Royal Air Force Germany
ISBN 3-935687-05-2

Size A-4, 68 pages, soft cover, full color, English text, over 185 pictures, graphics and b/w drawings, 1/48 scale plan as gate fold in the book's center. Our latest title covers the history of the F-4M (FGR.2) in the RAF Germany from the early arrivals of the jet in RAF Brüggen, Germany, to its final disbandment in RAF Wildenrath in 1992. All squadrons are included such as No. II (Shiny Two) Sqn in RAF Laarbruch, No. 14, 17 and 31 in RAF Brüggen and finally No. 19 and 92 (East India) in RAF Wildenrath.

A great source for the modeller with many detailed photographs!

Retail price EURO 17,95 (postage not included)

This set is for the experienced modeler only and should be kept out of reach of little children. Not suited for children under the age of 14!

