

AN
EXPERTS-CHOICE
DECAL

BARE-METAL FOIL CO. • P.O. BOX 82 • FARMINGTON, MI 48332

1/48 SCALE

NO. 48-52

OHIO and IOWA ANG F-84E THUNDERJETS

These decals are designed to fit the 1/48th scale
Tamiya F-84G and Monogram F-84E/G kits

To convert an F-84G to an F-84E, fill in the engine air inlet suction doors on the lower fuselage sides beneath the cockpit and the in-flight refuelling receptacle on the inboard leading edge of the left wing. You must also replace the "Swiss cheese" speed brake with the early style slotted speed brake.

Republic F-84E-10-RE Thunderjet 49-2261
162nd FIS, 178th FIW, OH ANG
Springfield Municipal Airport, Ohio 1956-7

OHIO AIR NATIONAL GUARD F-84E-10-RE
ANG SERIAL NO. 49-2261G



162nd FIS emblem, both sides

Polished aluminum
jet intake

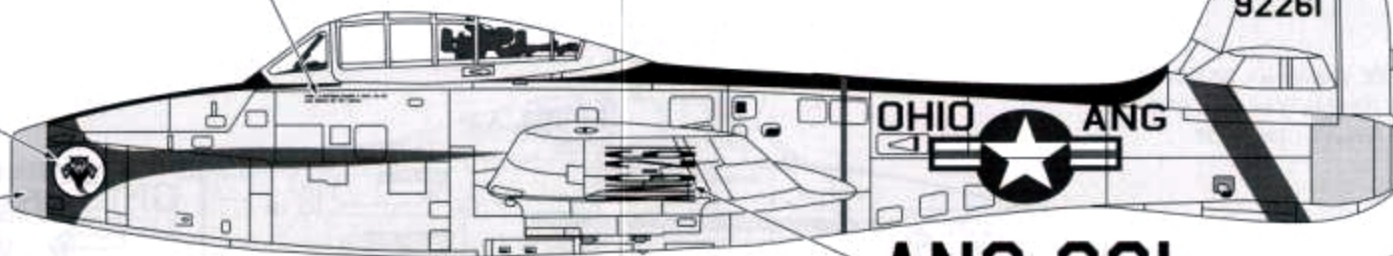

Gray dielectric fin cap
(approximately FS 36628)

ANG
92261

Dark blue Ohio map

ANG-261

Below left wing, above right wing

162nd FIS has red markings

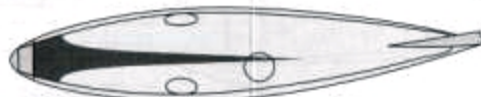

124th FIS emblem faces forward, both sides

Olive Drab (FS 34087) antiglare panel

Thin black stripe
(both sides)

Paint fin cap Insignia Red
FS11136

ANG
1508

Republic F-84E-25-RE Thunderjet 51-508
124th FIS, 132nd FIG (IA ANG)
Des Moines Airport, Iowa 1956
Aircraft transferred to Ohio ANG in 1957

Polished aluminum
jet intake



ANG-508

Below left wing, above right wing

IOWA AIR NATIONAL GUARD F-84E-25-RE
ANG SERIAL NO. 51-508G



Inside halves of wing tanks painted Flat Black

Air National Guard F-84Es

The first unit of the Ohio Air National Guard to fly the Thunderjet was the 166th Fighter Squadron, whose lineage traces back to the 364th Fighter Squadron, 357th Fighter Group (the famed Yoxford Boys) of WWII's Eighth Air Force. Based at Lockbourne AFB near Columbus, the 166th converted to the F-84C in March of 1950. They relinquished their Thunderjets for Mustangs in October 1952 but returned to jets

with the F-84E in January 1955, being redesignated the 166th Fighter Interceptor Squadron. In the Fall of 1957, the unit converted to the F-84F Thunderstreak. Two other Ohio ANG units flew the F-84E. One was the 162nd FIS which was descended from the 357th FG's 362nd FS and carries its Yoxford Boys emblem today on its F-16s. The squadron moved to Springfield Municipal Airport in September 1955 upon converting

from the F-51H Mustang to the F-84E. In November of 1957, the Thunderjets of the 162nd were replaced by the Republic F-84F Thunderstreak.

The 124th Fighter Interceptor Squadron of the Iowa Air National Guard's 132nd Fighter Interceptor Group, based at Des Moines Airport, received its Thunderjets in September of 1956 as replacements for the Lockheed F-80C Shooting Star. The squadron flew the

F-84E until April of 1958 when the Republic jet was replaced by the North American F-86L Sabre.

The Air Guard units featured on this decal sheet flew the Thunderjet in the air defense role during the height of the Cold War.

Air Guard Thunderjets were Natural Metal with Olive Drab (FS 34087) anti-glare panels on the upper fuselage forward and aft of the cockpit. National insignias were applied to the fuselage sides, above the left wing, and below the right wing. Most Thunderjets carried non-standard national insignia featuring "skinny" red bars. One set each of standard and "skinny bar" national insignia is provided on this decal sheet. ANG buzz numbers containing the "last three" of the aircraft's serial number were usually placed above the right wing and below the left wing. Keyed dashes on the number decals have been provided for proper alignment and placement relative to the "ANG."

ANG

Republic F-84E-25-RE Thunderjet 51-508
162nd FIS, 178th FIG (OH ANG), ex-Iowa ANG
Springfield Municipal Airport, Ohio 1957

Expert's-Choice 48-52

ANG-261/-638

ANG-508

ANG-638 ANG-508

Overlap decals here for proper alignment

Left main wheel well decal placement

ANG

Left main gear doors decal placement

Send \$2.50 for a complete list of other beautiful and accurate EXPERT'S-CHOICE Decals and other products.

Match corners of fuselage stripes



Paint fin cap Insignia Red FS1136

Thin black stripe (both sides)

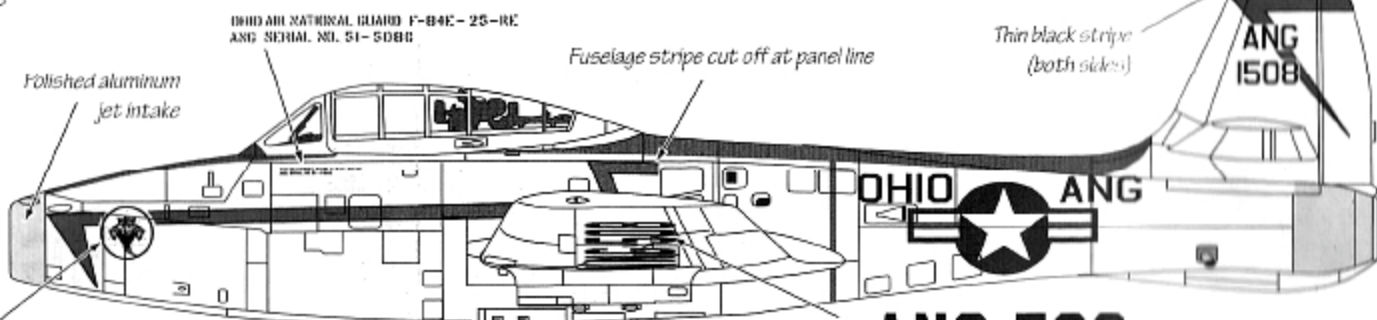

Polished aluminum jet intake

Fuselage stripe cut off at panel line

OHIO AIR NATIONAL GUARD F-84E-25-RE
ANG SERIAL NO. 51-508C

ANG-508

Below left wing, above right wing

Use the enclosed squadron patches on a display base or put them on a coffee mug!



162nd FIS emblem, both sides



F-84E slotted speed brake



Inside halves of wing tanks extremely chipped and faded Flat Black

Gray dielectric fin cap (approximately FS 36628)

Republic F-84E-30-RE Thunderjet 51-638
166th FIS, 121st FIG (OH ANG)
Lockbourne AFB, Ohio 1956-7

OHIO AIR NATIONAL GUARD F-84E-30-RE
ANG SERIAL NO. 51-638C

Olive Drab (FS 34087) anti-glare panel

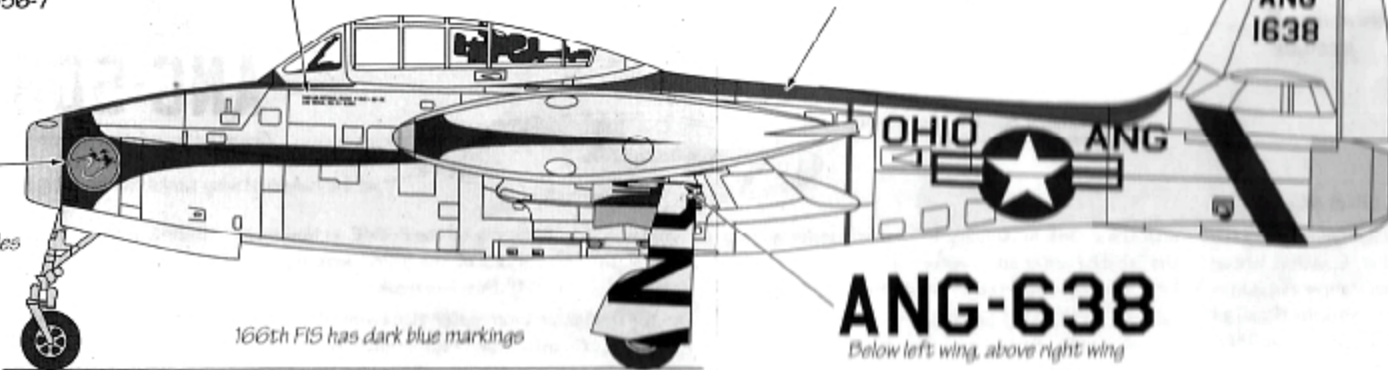

ANG 1638

Red Ohio map



166th FIS emblem, both sides

166th FIS has dark blue markings

ANG-638

Below left wing, above right wing

Custom Art By
ICM Graphics

Use Bare-Metal Foil for a realistic finish on natural metal and exhaust areas.