

# BRITISH WWII FIGHTER 1:48 SCALE PLASTIC KIT



eduard

## intro

## DUAL COMBO!



In September 1941, a hitherto unknown German radial engine fighter appeared in the west European sky. The new airplane was superior to British fighters, most distressingly to the Spitfire Mk.V. The German design was soon recognized as the Focke-Wulf Fw 190 A. The losses suffered by the RAF over western Europe rose rapidly and the crisis was serious enough that the RAF ceased the majority of daytime operations in November, 1941. The next attempt to resume these types of sorties was made in March 1942. Loss rates remained unacceptably high and the RAF was forced to stop ops once again. All this was thanks to the Focke-Wulf Fw 190 A. The first response to the new German weapon was the Spitfire Mk.VIII, but the design changes were so complex that initiating timely production was not possible. In June, 1942, a German pilot landed by mistake on a British airfield delivering a completely intact Fw 190 fighter into RAF hands. Comparative trials between the Focke-Wulf and Spitfire Mk.V began almost immediately. These mock encounters confirmed the situation over the front – the chances of a British fighter surviving an encounter with the Fw 190 were slim. The only British fighter aircraft deemed suitable to oppose them were the Spitfire Mk.VII and VIII powered by the Merlin 61 engine. As mentioned above these were some time away of being ready for series production. But there was another way of getting a powerful fighter quickly - by mating the Merlin 61, with its two-stage supercharger, with the fuselage of the Spitfire Mk.Vc. Two Mk.Vc airframes, AB196 and AB197, were selected for this purpose and were strengthened with modified longerons to accommodate the more powerful and heavier engine. The example was finished on February 26 and the second on March 27, 1942. Flight trials were successful and the order for series production was issued almost immediately. Series production began in June 1942 and the first Mk.IXs found their way to No. 64 Squadron in July. Performance improved significantly in comparison to the Mk.V. A top speed of 409 mph at 28,000 feet was higher by 40mph, and the service ceiling rose from 36,200 to 43,000 feet. The Mk.IX could climb at 4,000 feet per minute. The RAF finally had a fighter aircraft capable of opposing the Fw 190 A. Three main versions of the Mk.IX were produced. The F.IX was powered by the Merlin 61 and was the only version on the assembly line in early 1943. The next version was the LF Mk.IX powered by the Merlin 66. This engine was designed to do its best at low altitudes. The third version, manufactured along with the LF, was the high-altitude HF Mk.IX with the Merlin 70. The majority of Mk.IXs manufactured were equipped with the so-called 'C' wing. Four 20mm cannon or two 20mm cannon and four .303 machine guns could be installed in the wings. From 1944, the strengthened 'E' wing was produced. Four .303 machine guns were replaced with two .50 heavy machine guns. Bomb racks for 250lb bombs were fitted under each wing typically. The Mk.IX became the second most numerous version of the Spitfire with a total of 5653 examples being built. The Mk.IX began to replace the Mk.V from June, 1942. Thanks to the new fighter, the RAF was ready to fight against the Luftwaffe over occupied Europe. Spitfire Mk.IXs served with the RAF to the end of war. In the postwar era, foreign air forces flew this version as well. Czechoslovak, Norwegian, Danish, and Canadian air forces operated numbers of Mk.IXs and they were not alone. Spitfires would find themselves in combat again. Czechoslovakia sold its Spitfire Mk.IXs to Israel in 1948 and these aircraft formed the backbone of the newly born Israeli air force in the fight against their Arab neighbours. The Merlin 266, built under licence by the Packard Motor Company, powered the next version, the Spitfire Mk.XVI. The early production examples were – except for the engine - almost identical to the Mk.IX. Late production blocks had bubble canopies and redesigned rear fuselage.

## úvodem

V září 1941 se na evropské obloze objevil dosud neznámý německý stíhací letoun poháněný hvězdicovým motorem. Nová stíhačka měla nad britskými, zejména Spitfirem Mk.V, zřetelnou převahu. V německé konstrukci byl záhy rozpoznán Focke-Wulf Fw 190 A. Ztráty RAF nad západní Evropou začaly rychle narůstat až to té míry, že britské letectvo muselo v listopadu 1941 zastavit většinu denních operací nad evropským kontinentem. Pokus o spuštění tohoto typu bojových letů byl uskutečněn v březnu 1942. Počty ztrát však byly opět neúnosné, což znovu vedlo k jejich zastavení. Vše díky Focke-Wulfům Fw 190 A. Prvním pokusem o odpověď na novou německou zbraň se stal Spitfire Mk.VIII, avšak komplexní přístup ke změnám konstrukce letounu způsobil, že nebylo možné jej dostat do sériové výroby v dostatečně blízkém časovém horizontu. V červnu 1942 přistál jeden z německých pilotů omylem na britském letišti a předal tak do britských rukou nepoškozený Fw 190 A. Srovnávací zkoušky Focke-Wulfu a Spitfire Mk.V začaly téměř neprodleně. Cvičné souboje plně potvrdily situaci na frontě – šance britské stíhačky přestat setkání s Fw 190 bez úhony nebyly vysoké. Jediné britské stíhačky schopné postavit se plnohodnotně německému typu byly Spitfirey Mk.VII a Mk.VIII poháněné motorem Merlin 61. Jak však bylo poznamenáno výše, nedalo se čekat, že v dohledné době dospějí do fáze sériové výroby. Byla zde však ještě jedna cesta jak získat dostatečně výkonnou stíhačku – zabudovat Merlin 61 s dvoustupňovým kompresorem do základního draku Spitfire Mk.V. Pro tento experiment byly vyčleněny dva draky, AB196 a AB197. Prošly zpevněním, aby mohl být zastavěn výkonnější a těžší motor. První z nich byl dokončen 26. února, druhý pak 27. března 1942. Letové testy proběhly natolik úspěšně, že byla objednána sériová výroba. Ta se plně rozběhla v červnu 1942 a první Mk.IX se u bojové jednotky, No. 64 Squadrony, objevily v červenci. V porovnání s Mk.V se výkony zřetelně zvýšily. Maximální rychlost byla v 28.000 stopách vyšší o 40 mph, operační dostup se zvýšil z 36.200 na 43.000 stop. Mk.IX mohl stoupat rychlostí 4000 stop za minutu. RAF tedy konečně dostalo stíhačku, kterou mohlo směle postavit proti Fw 190 A. Vyráběny byly tři hlavní verze Mk.IX. Verze F Mk.IX byla poháněna motorem Merlin 61 a z montážní linky sjížděla až do počátku roku 1943. Na ni navázaly LF Mk.IX poháněná motorem Merlin 66 a určená k operacím v nižších výškách a HF Mk.IX s motorem Merlin 70 konstruovaným naopak pro výškové lety. Většina Mk.IX byla vyrobena s křídlem typu C. V něm mohla být instalována výzbroj složená ze čtyř kanonů ráže 20 mm nebo ze dvou kanonů ráže 20 mm a čtyř kulometů ráže 0,303 palce. V roce 1944 se objevilo zpevněné křídlo typu E. Čtveřice 0.303 kulometů byla nahrazena dvojicí kulometů ráže 0.50 palce. Pod každou polovinou křídla byly standardně namontovány závěsníky pro 250lb pumy. Verze Mk.IX se stala druhou nejpočetnější verzí Spitfire s 5653 vyrobenými kusy. Mk.IX začaly nahrazovat Mk.V v červnu 1942. Díky nové stíhačce byla RAF opět schopná bojovat proti Luftwaffe nad okupovanou Evropou. Ve své výzbroji si typ ponechala až do konce války. Po ukončení bojů se verze dostala i do výzbroje dalších letectev. Československé, norské, dánské, kanadské a další letectva používala desítky Mk.IX. Spitfirey Mk.IX se však do bojů dostaly i v této době. Československo prodalo své Spitfirey v roce 1948 do Izraele, kde se v bojích s arabskými sousedy staly páteřním typem nově vznikajících izraelských vzdušných sil. Na verzi Mk.IX navázala verze Mk.XVI. První vyrobené kusy se od Mk.IX lišily zejména použitým motorem, kdy letoun poháněl Packard Merlin 266, což byl v licenci vyráběný Merlin 66. Pozdější produkce také dostala snížený hřbet trupu a přepracovaný překryt kokpitu.

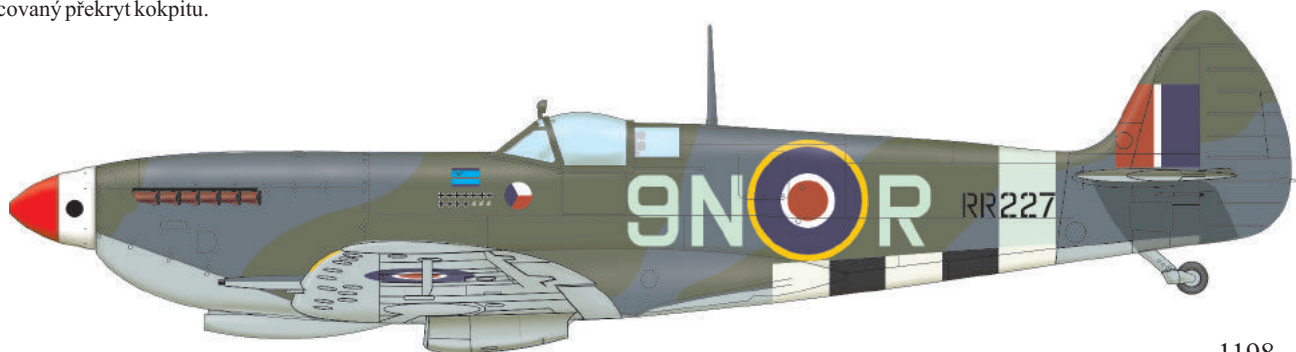

ATTENTION



UPOZORNĚNÍ



ACHTUNG



ATTENTION



注意



Carefully read instruction sheet before assembling. When you use glue or paint, do not use near open flame and use in well ventilated room. Keep out of reach of small children. Children must not be allowed to suck any part, or pull vinyl bag over the head.



Před započítím stavby si pečlivě prostudujte stavební návod. Při používání barev a lepidel pracujte v dobře větrané místnosti. Lepidla ani barvy nepoužívejte v blízkosti otevřeného ohně. Model není určen malým dětem, mohlo by dojít k požití drobných dílů.

INSTRUCTION SIGNS \* INSTR. SYMBOL \* INSTRUKTION SINNBILDEN \* SYMBOLES \* 記号の説明

OPTIONAL  
VOLBABEND  
OHNOUTOPEN HOLE  
VYVRTAT OTVORSYMMETRICAL ASSEMBLY  
SYMETRICKÁ MONTÁŽREMOVE  
ODŘÍZNOUTREVERSE SIDE  
OTOČITAPPLY EDUARD MASK  
AND PAINT  
POUŽÍT EDUARD MASK  
NABARVIT

PARTS



DÍLY



TEILE



PIÈCES



部品

D&gt;

8280 D

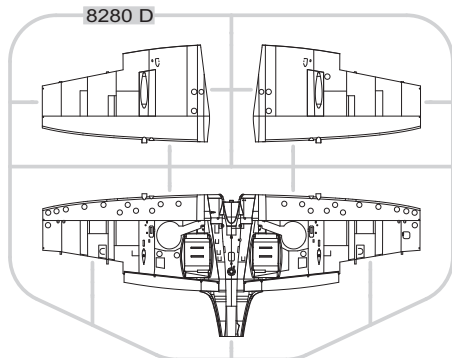

J&gt;

PLASTIC PARTS

8280 J

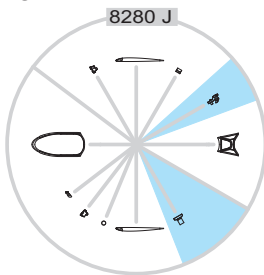

F&gt;

8280 F

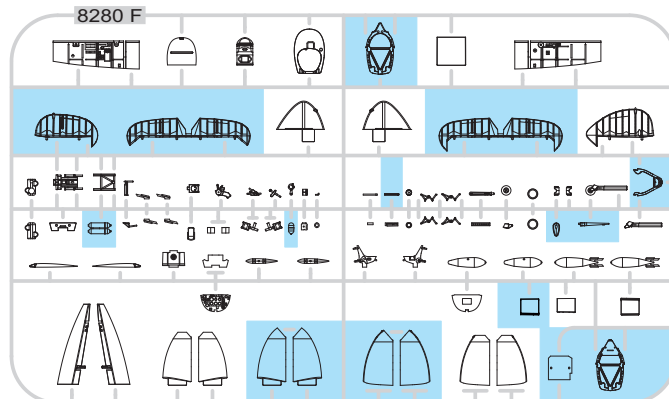

G&gt;

8280 G

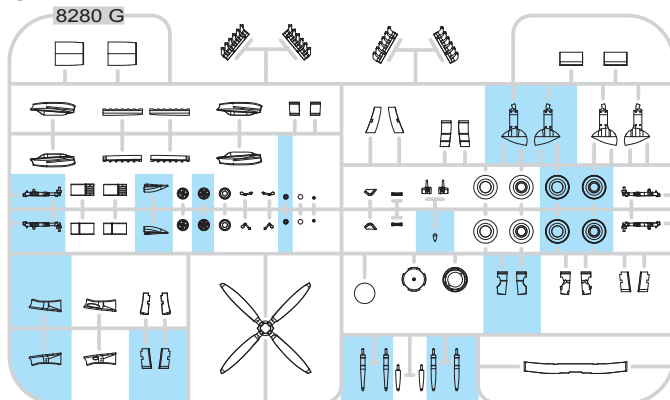

L&gt;

8280 L

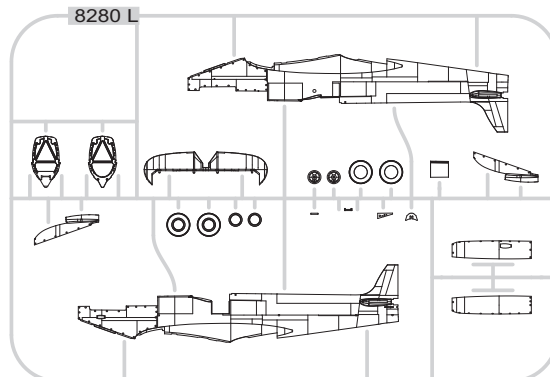

K&gt;

8280 K

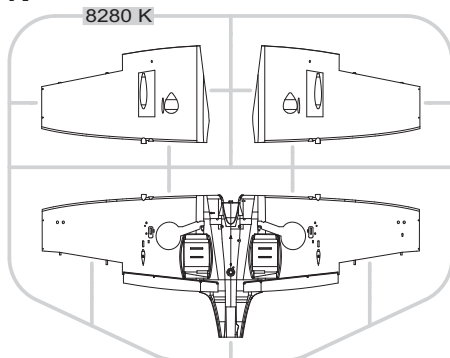
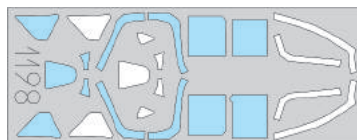
eduard  
MASK

PE - PHOTO ETCHED DETAIL PARTS

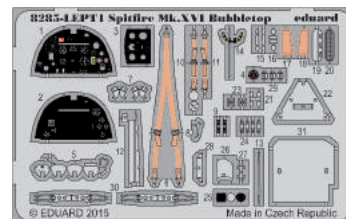

-Parts not for use. -Teile werden nicht verwendet. -Pièces à ne pas utiliser. -Tyto díly nepoužívejte při stavbě. - 使用しない部品

COLOURS



BARVY



FARBEN



PEINTURE



色

GSI Creos (GUNZE)		
AQUEOUS	Mr.COLOR	
H 4	C4	YELLOW
H 11	C62	FLAT WHITE
H 12	C33	FLAT BLACK
H 13	C3	FLAT RED
H 25	C34	SKY BLUE
H 33	C81	RUSSET
H 77	C137	TIRE BLACK
H 90	C47	CLEAR RED
H 94	C138	CLEAR GREEN
	C361	MEDIUM SEAGRAY

AQUEOUS	Mr.COLOR	
	C362	OCEAN GRAY
	C363	DARK GREEN
	C364	AIRCRAFT GRAY-GREEN
	C368	SKY
	C370	PRU BLUE
Mr.METAL COLOR		
	MC214	DARK IRON
	MC218	ALUMINIUM
Mr.COLOR SUPER METALLIC		
	SM06	CHROME SILVER

# Mk.XVI Bubbletop

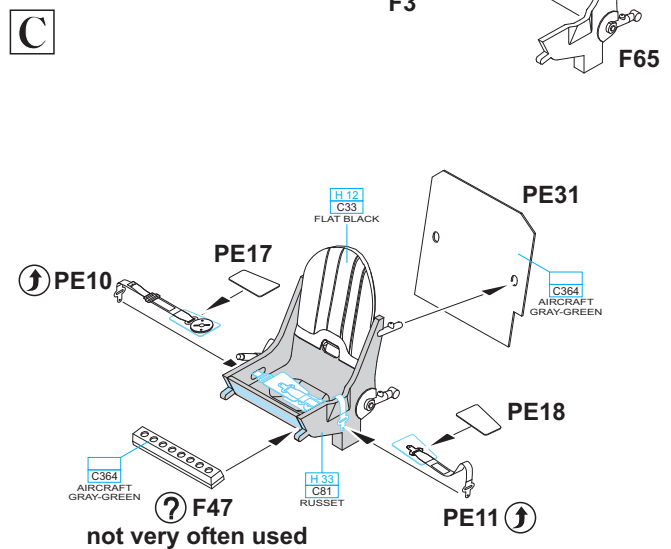
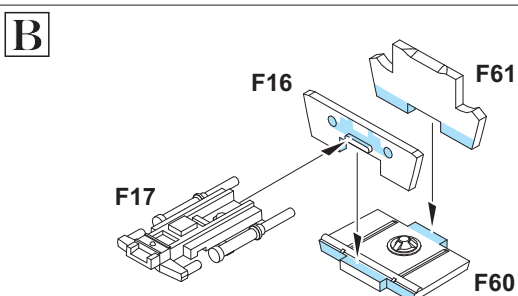
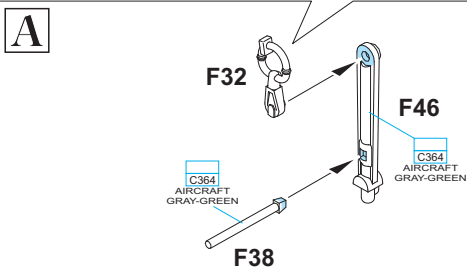
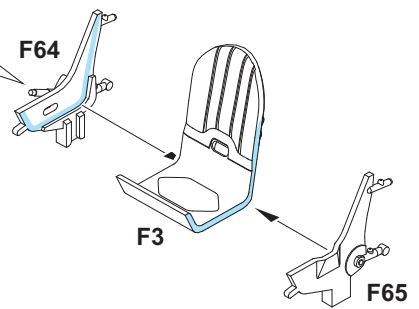
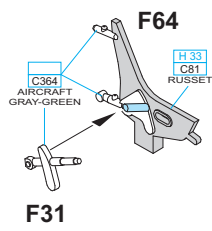
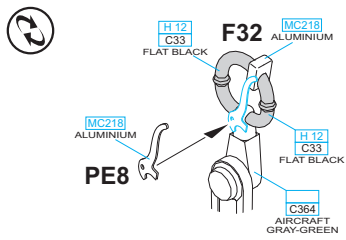
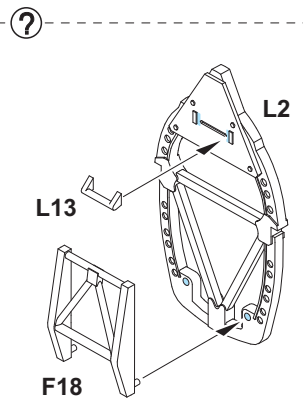
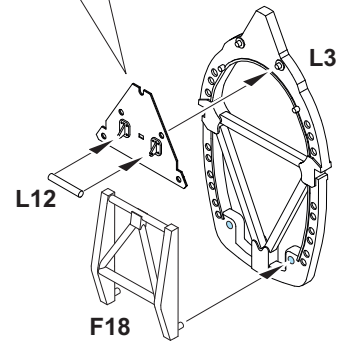
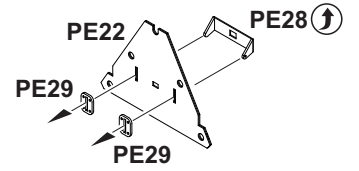
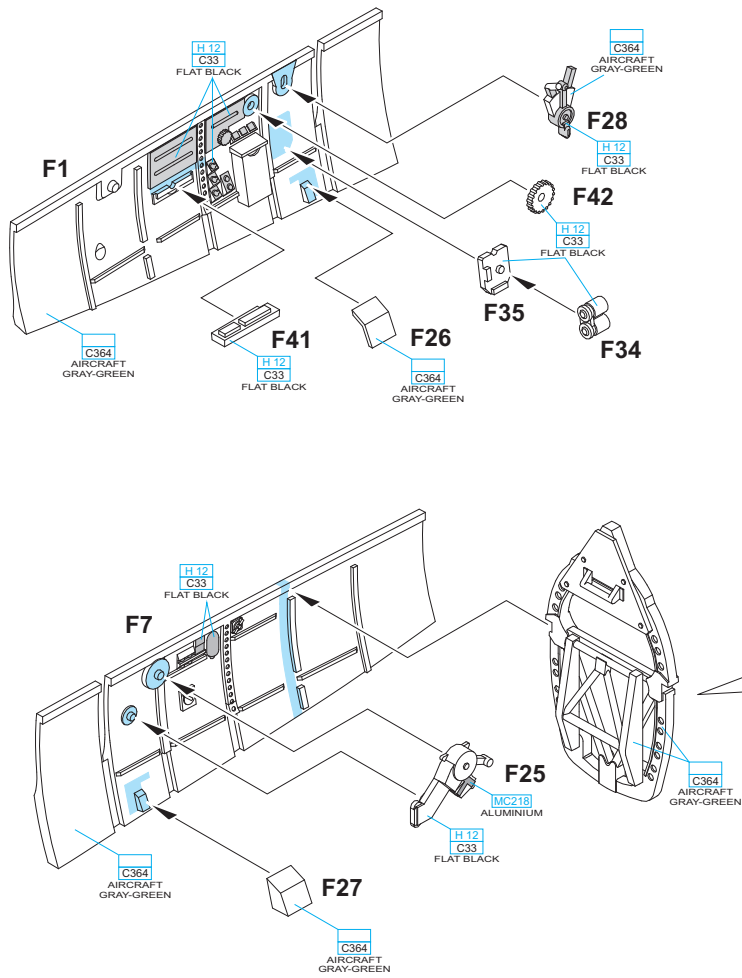

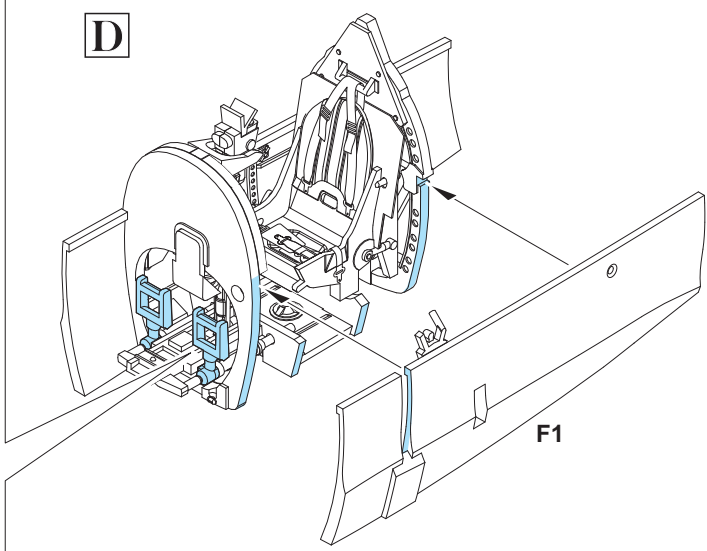
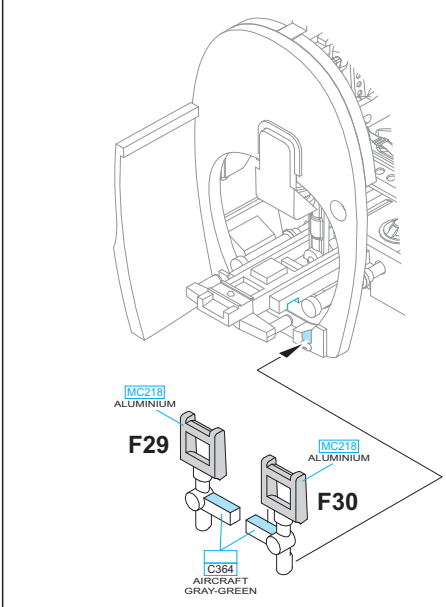
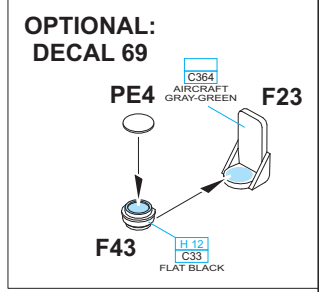
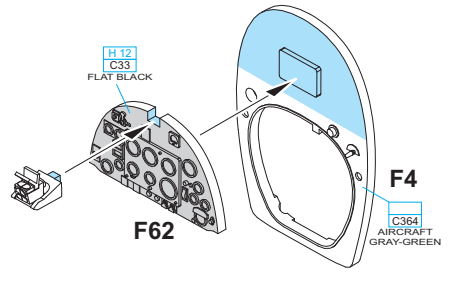
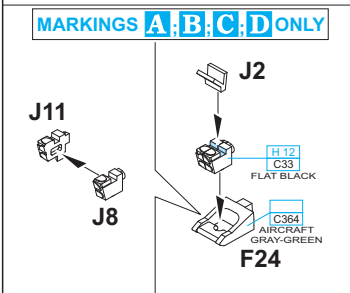
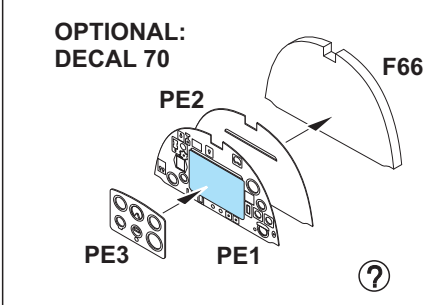
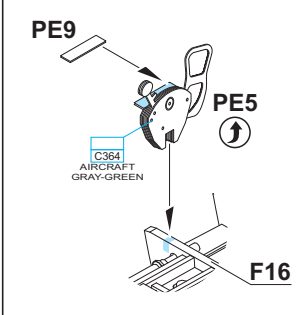
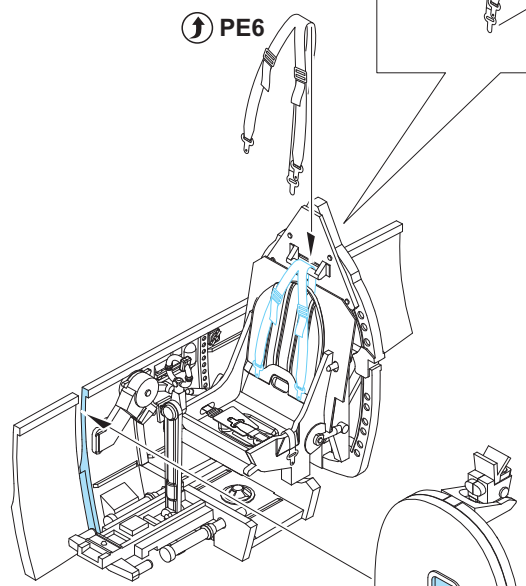
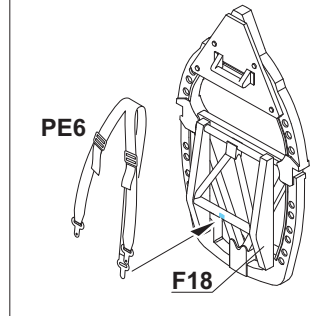
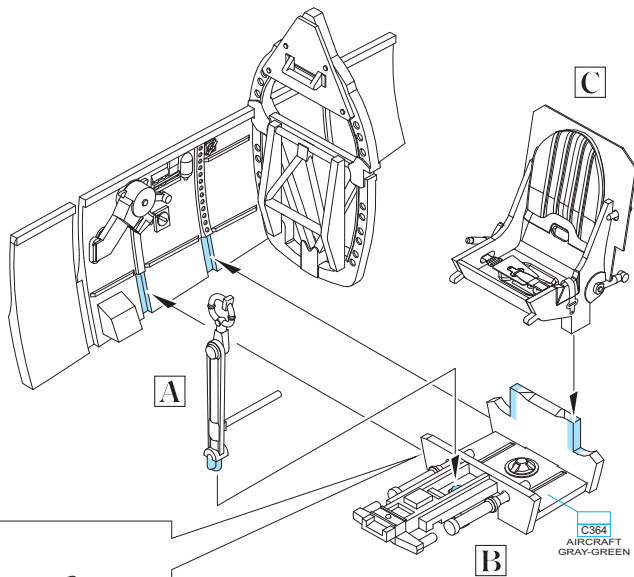

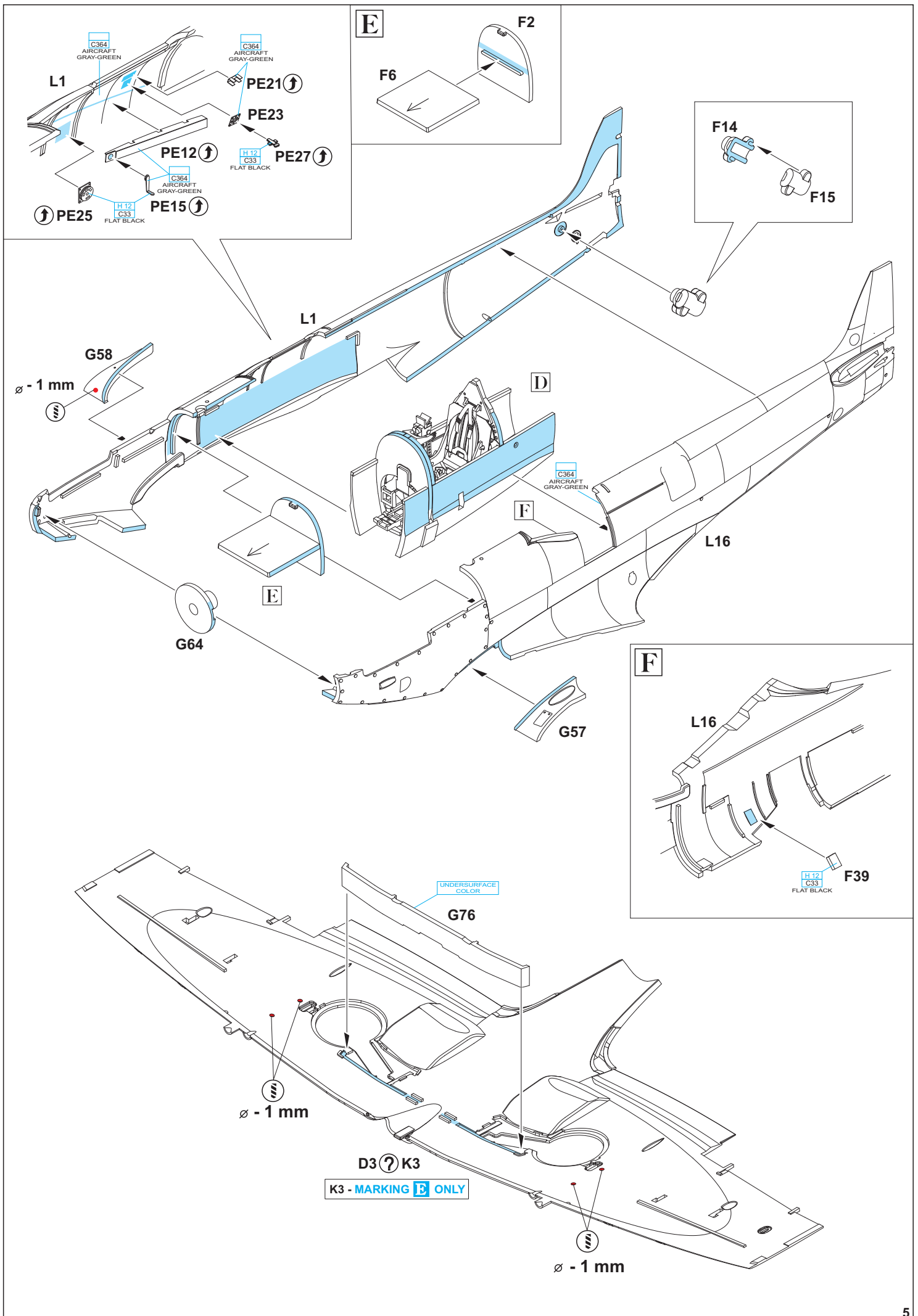

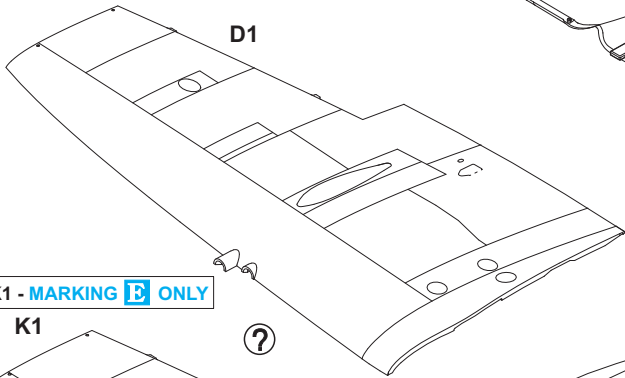
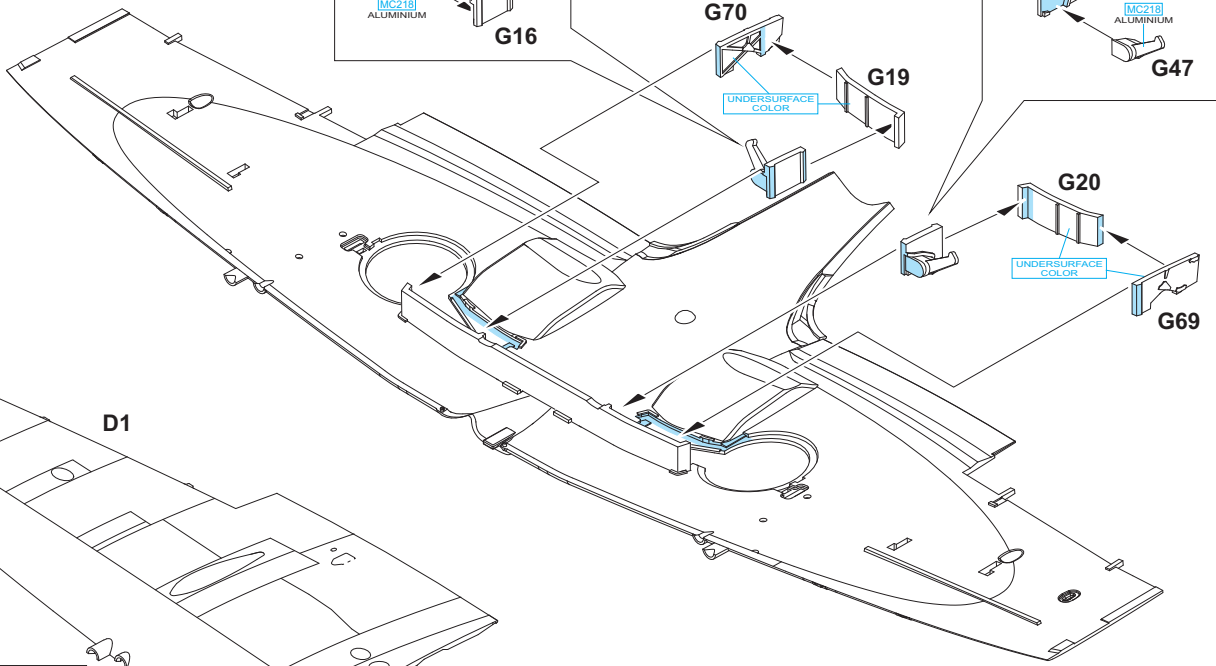
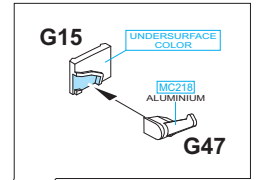
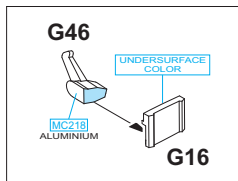

**K1 - MARKING B ONLY**

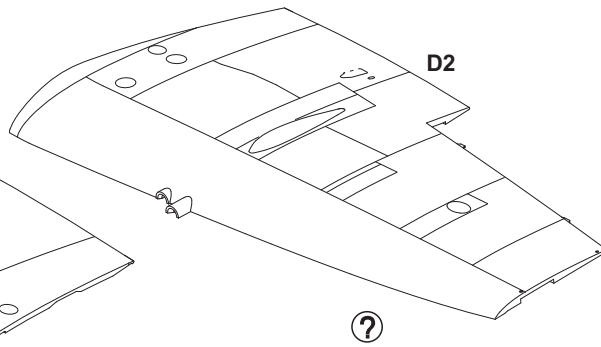
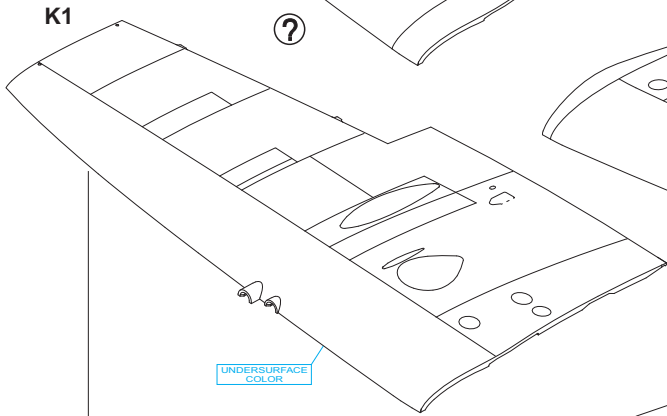

?

**K2 - MARKING B ONLY**

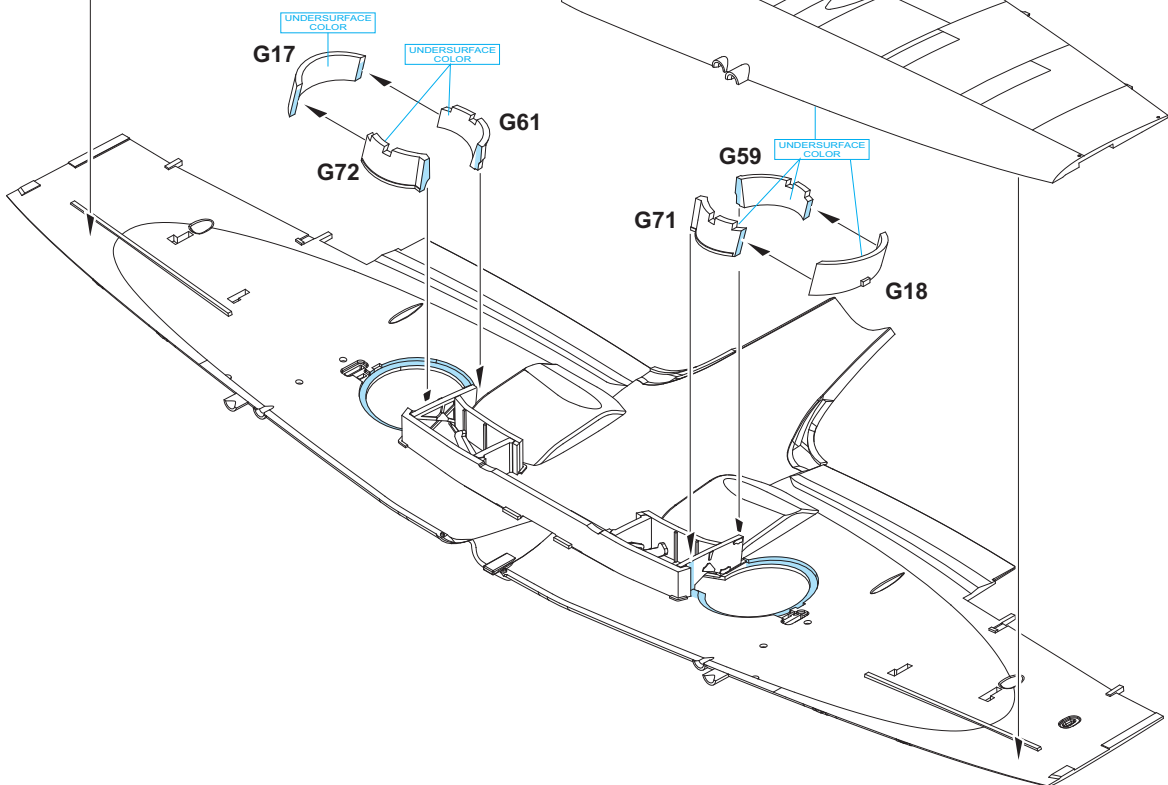
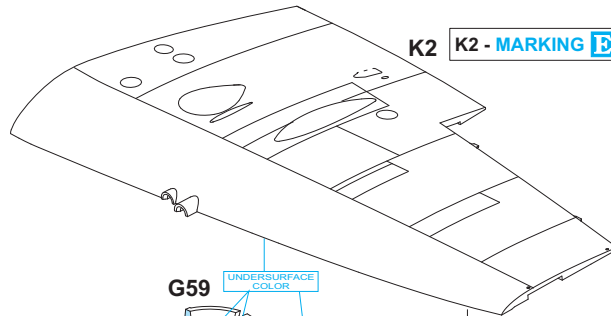

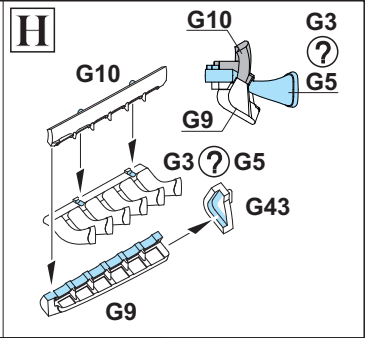
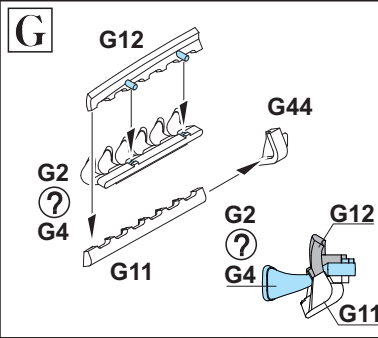
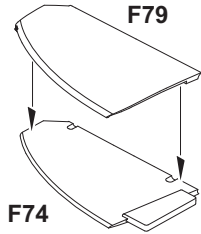
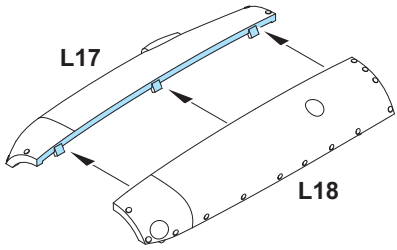

G2, G3 - MARKINGS **D**; **E** ONLY

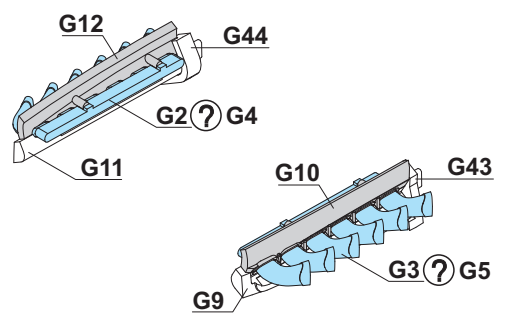
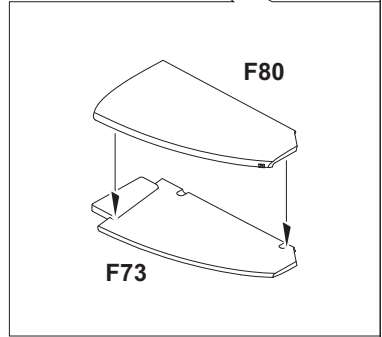
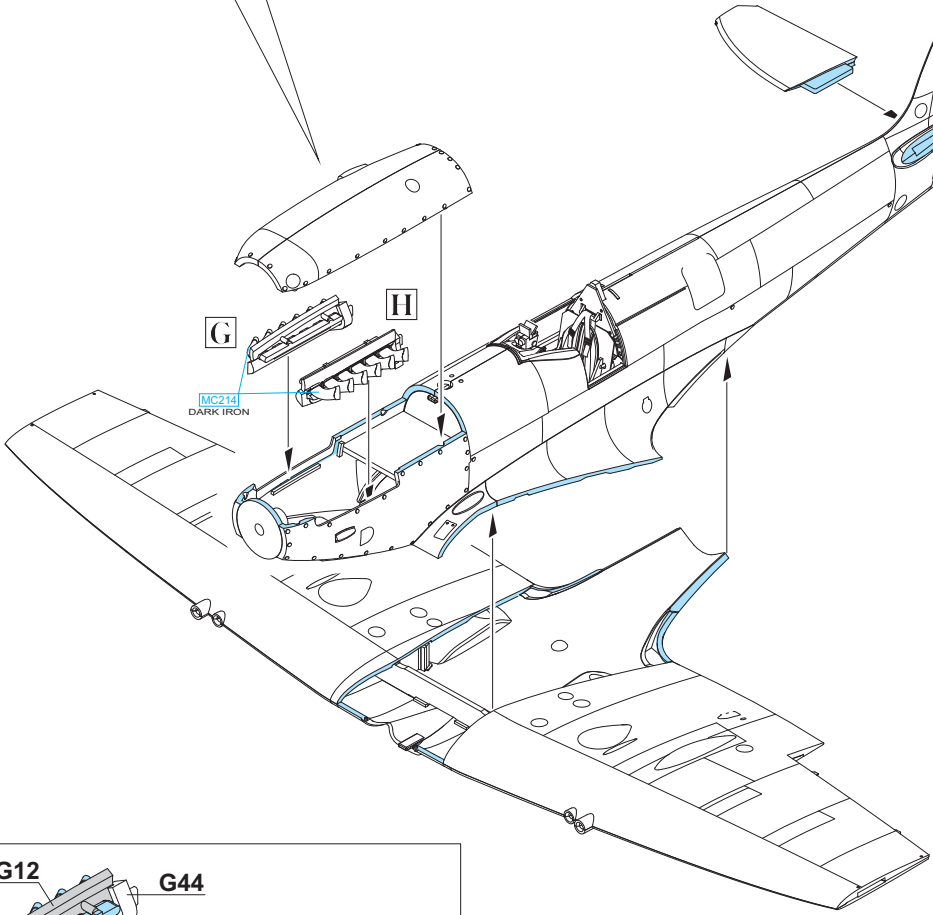

GLUE PARTS F52 & F53 ONE BY ONE

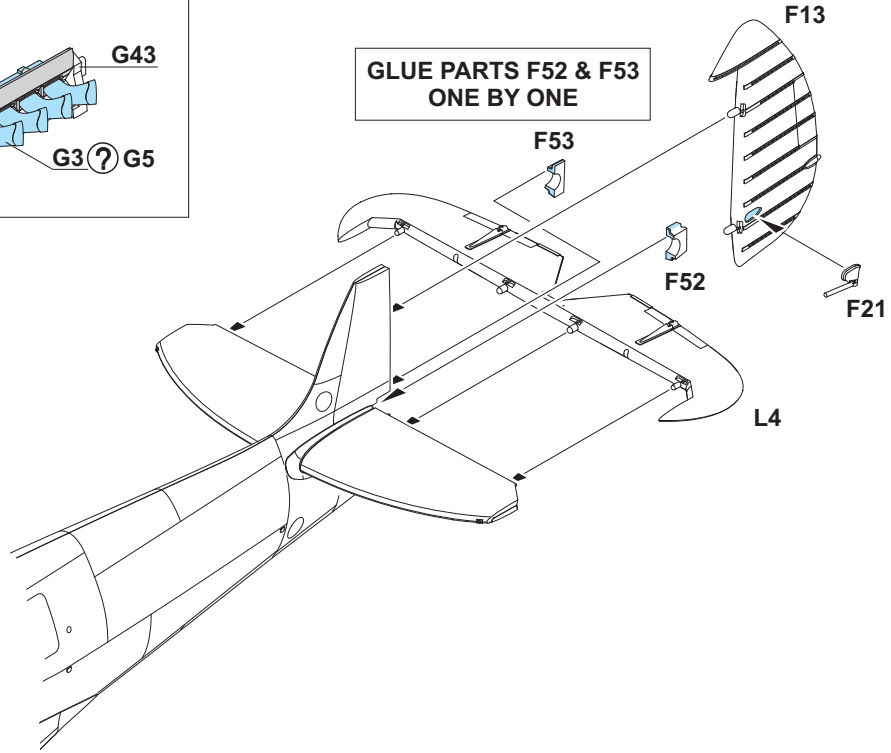

F11 - MARKING D ONLY

H 94  
C138  
CLEAR GREEN

J6 ? F59

F11

?

F72

L15

L14

CAMOUFLAGE  
COLOR

F71

F10

J1 ? F58

H 90  
C47  
CLEAR RED

H 90  
C47  
CLEAR RED

F10 - MARKING D ONLY

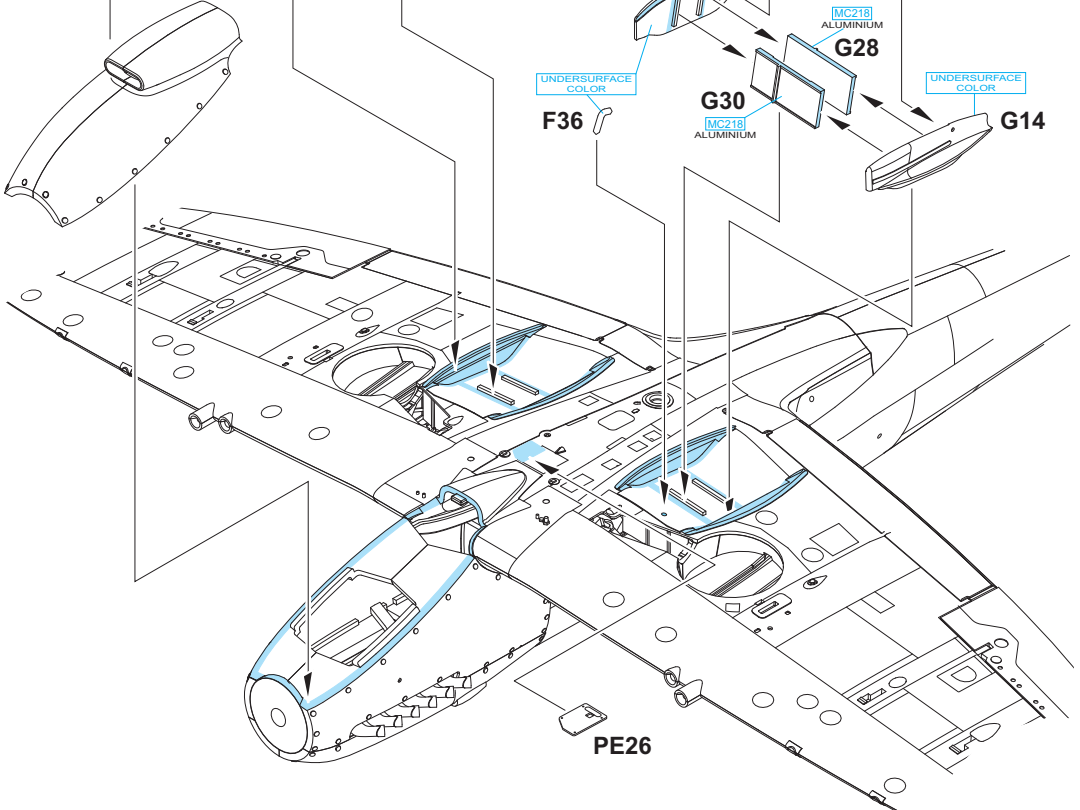
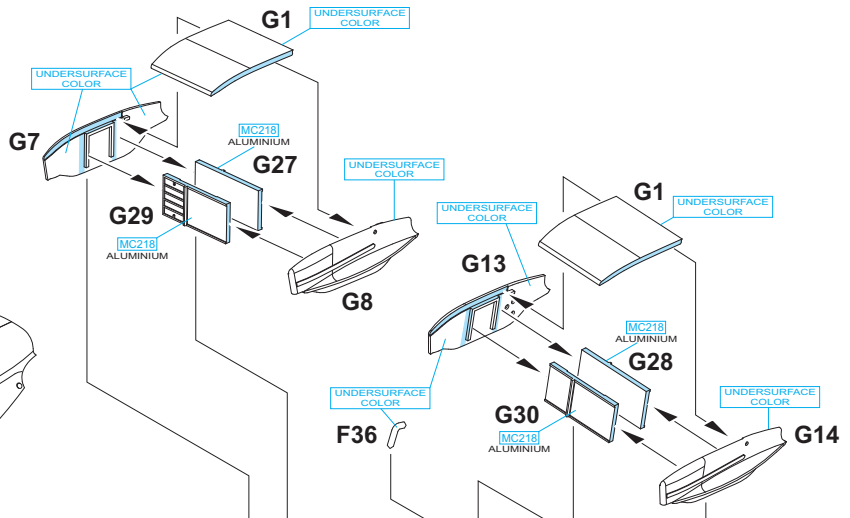
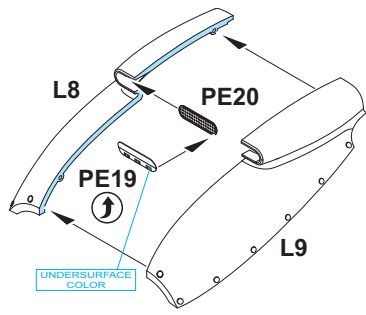



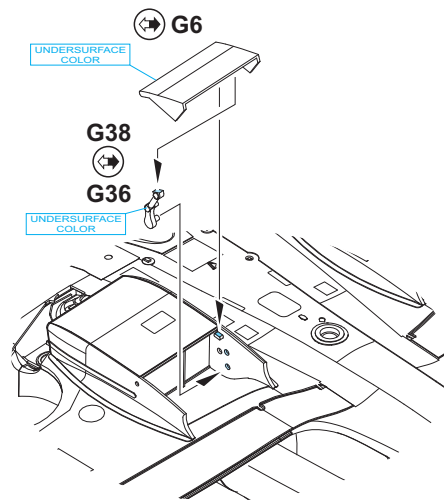
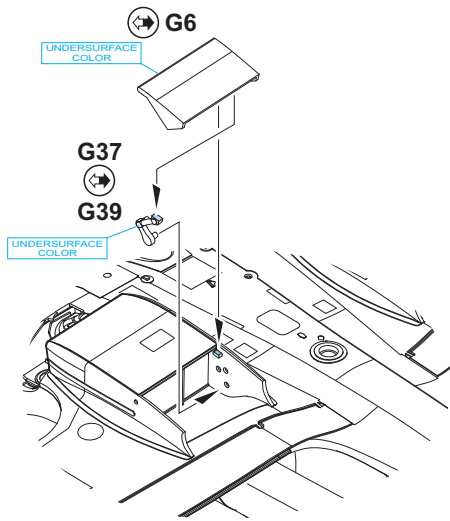
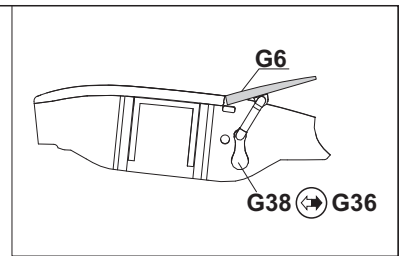
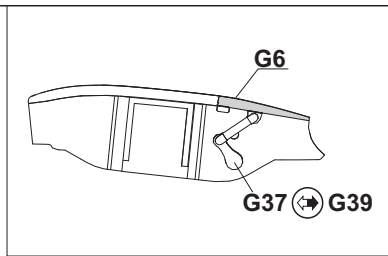

MARKING **B** ONLY

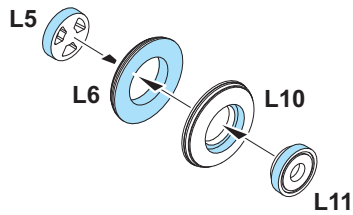

MARKING **B** ONLY

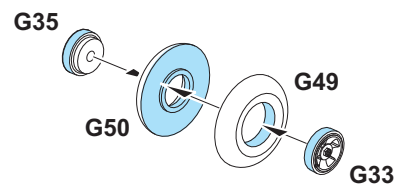
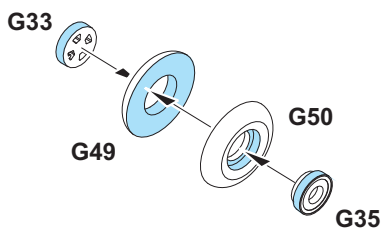
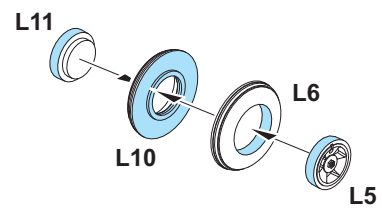

**L**

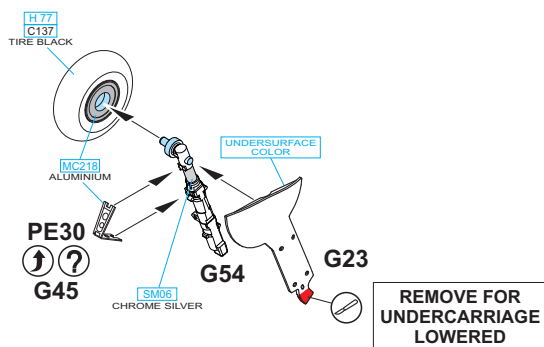

**R**

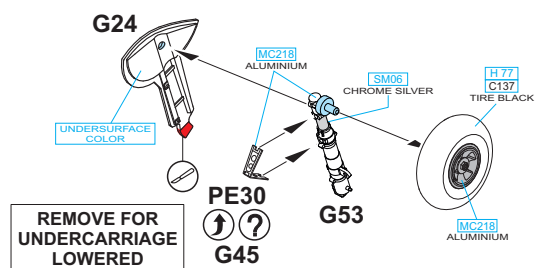

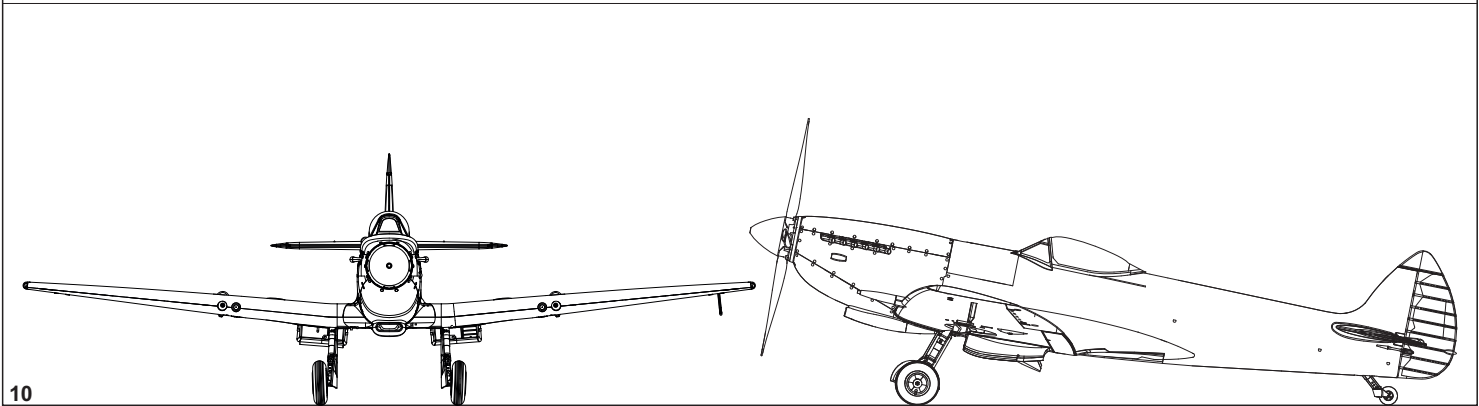
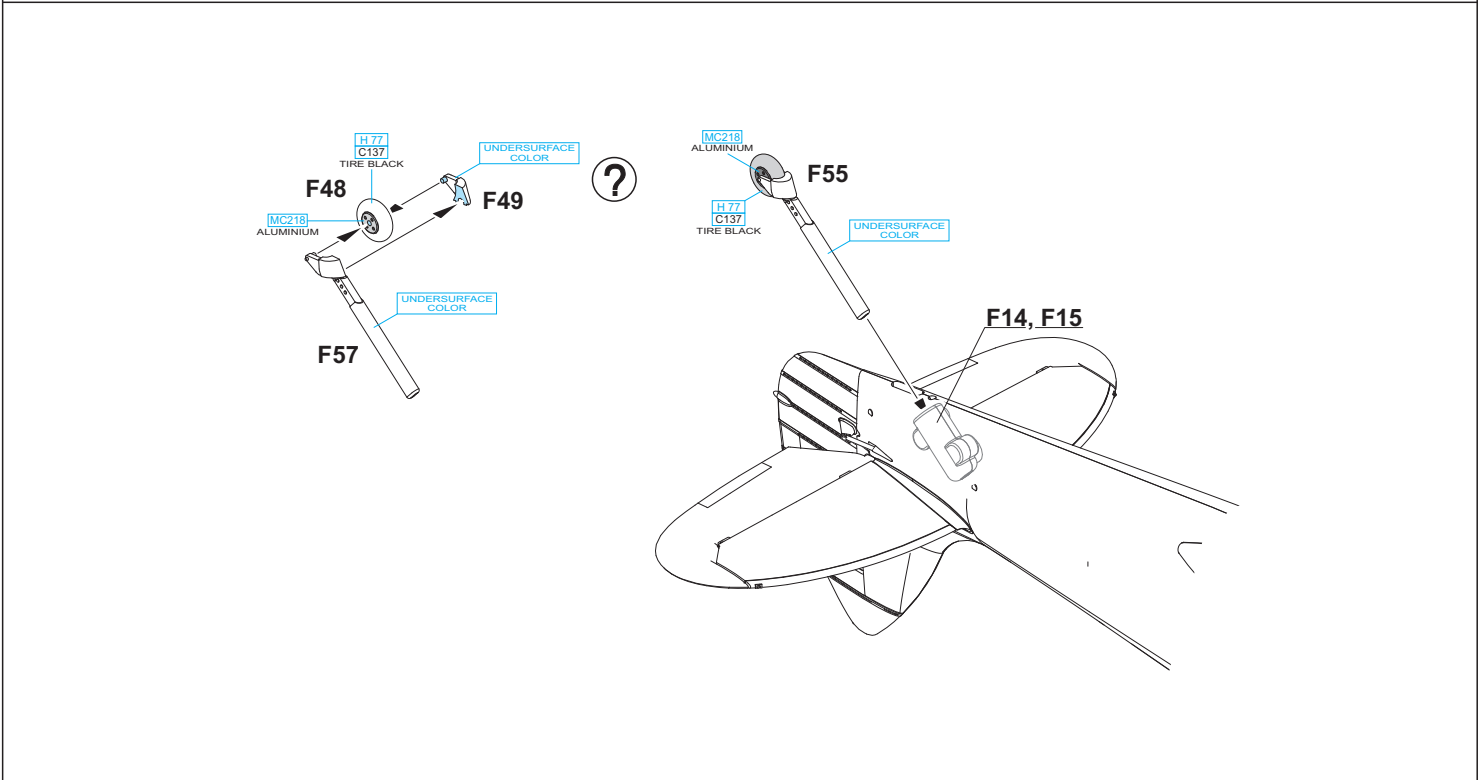
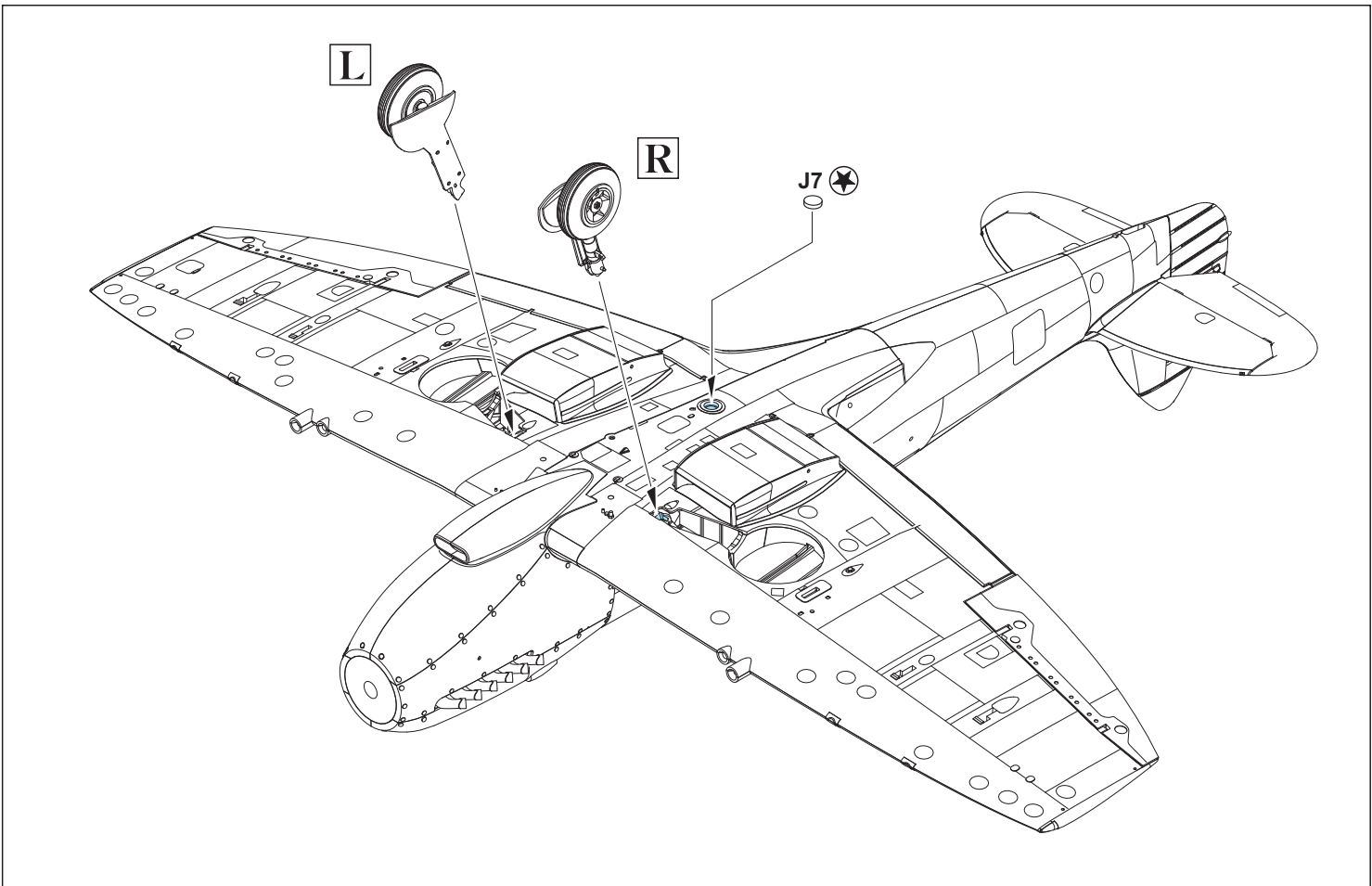

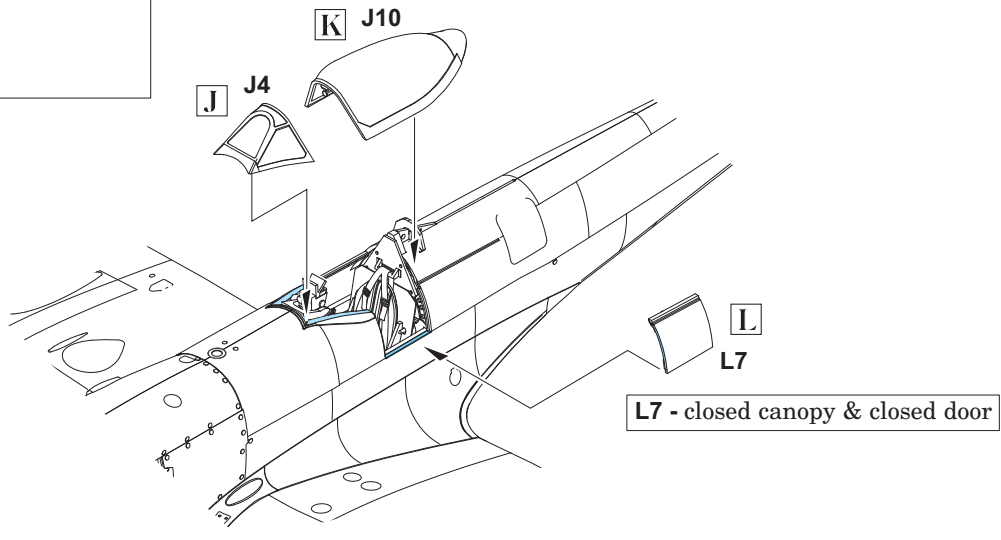
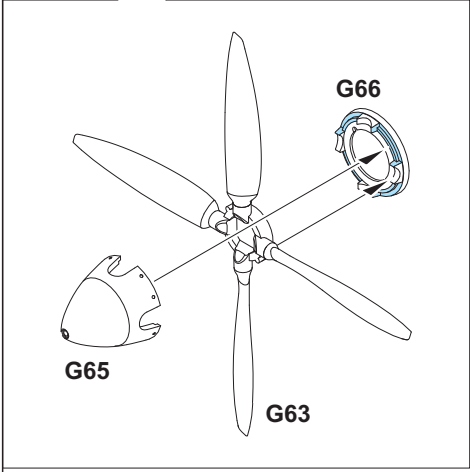
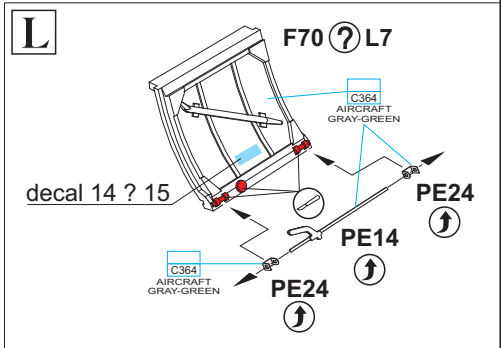
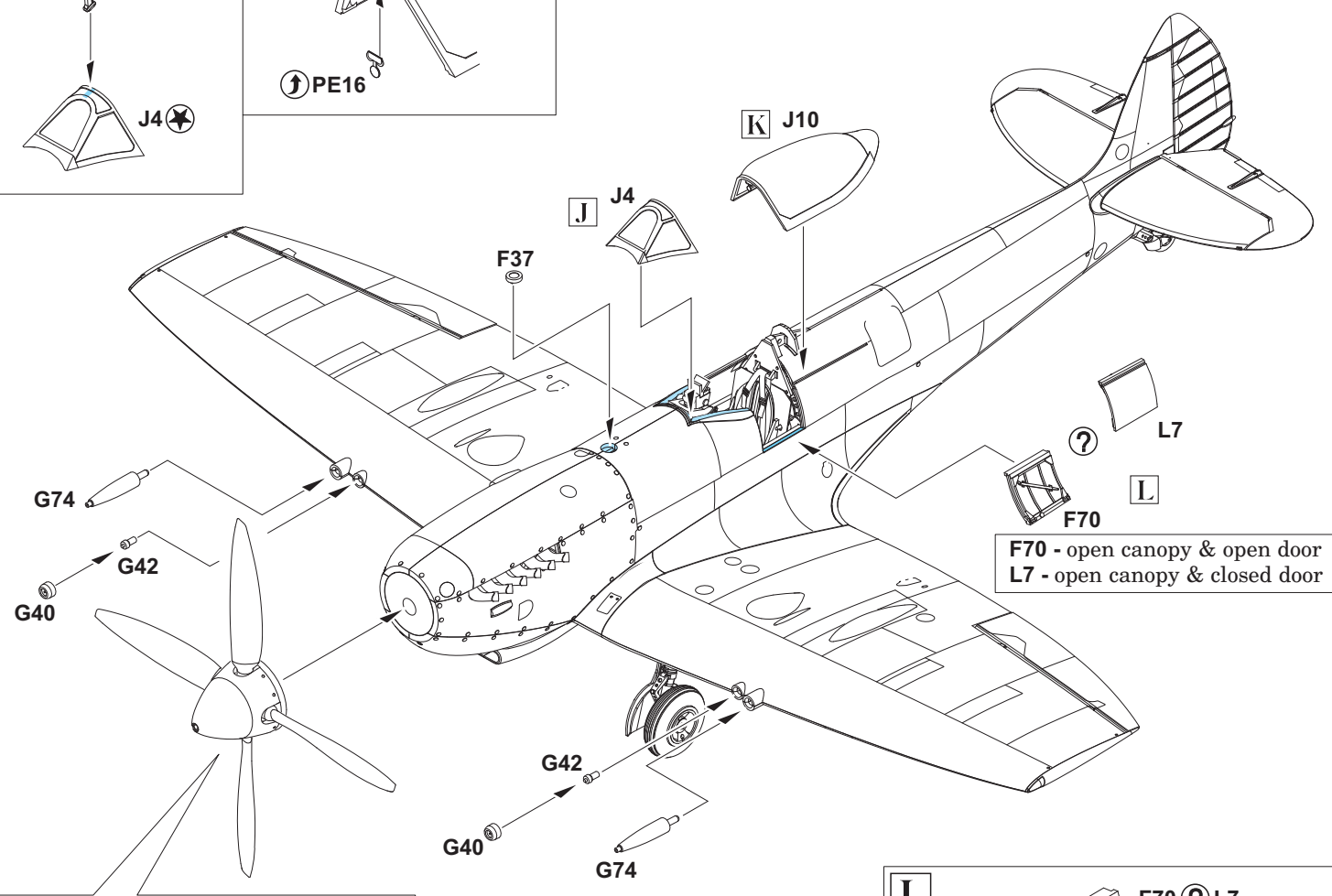
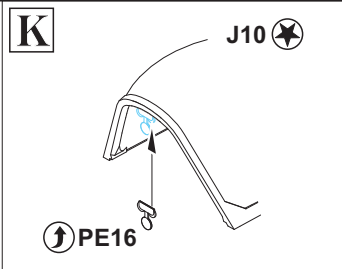
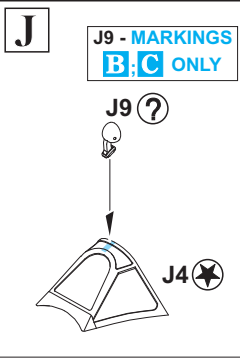

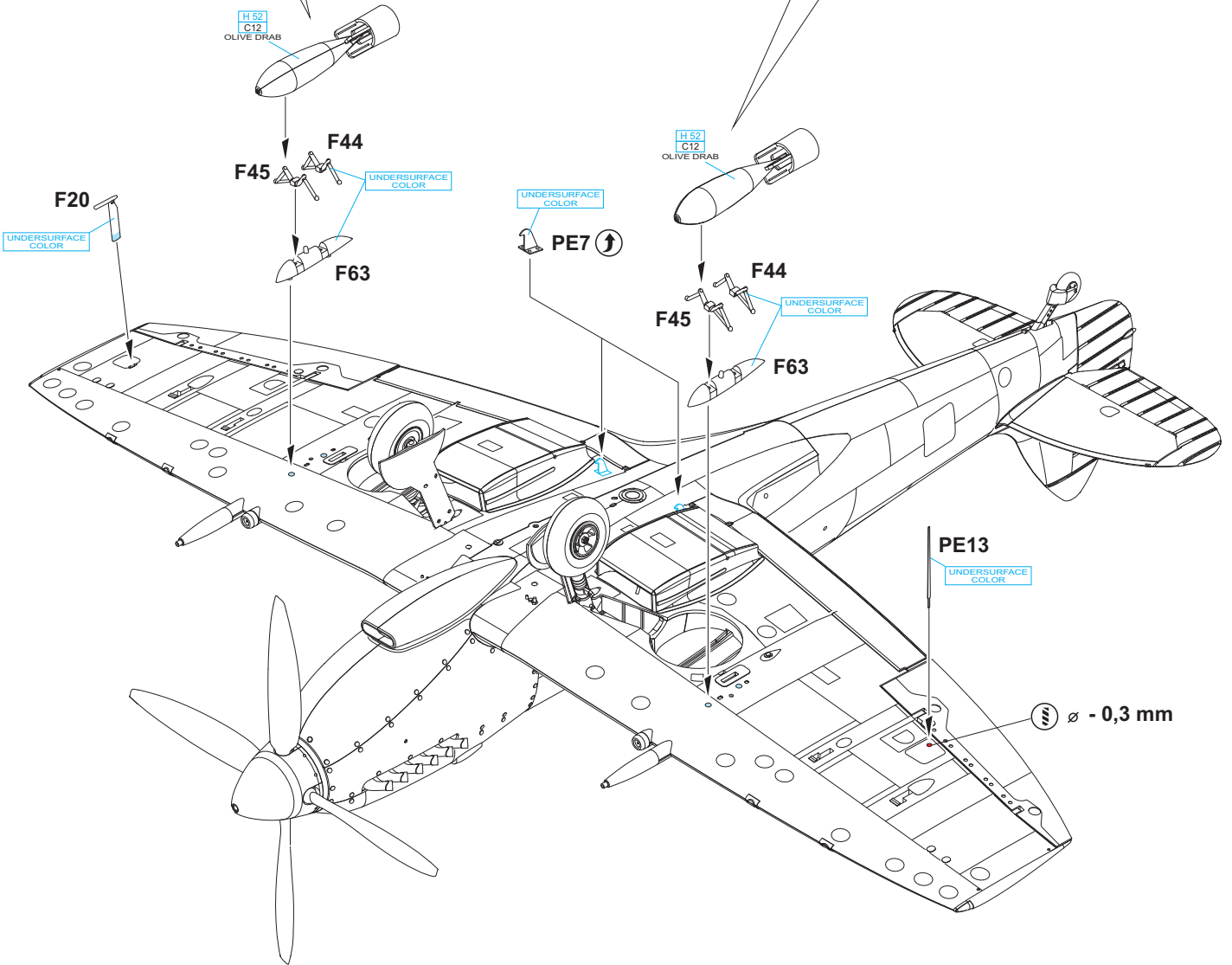
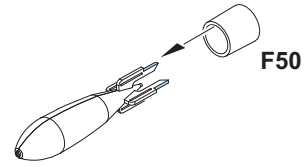
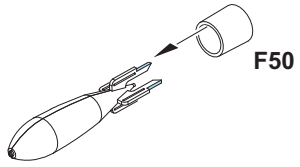
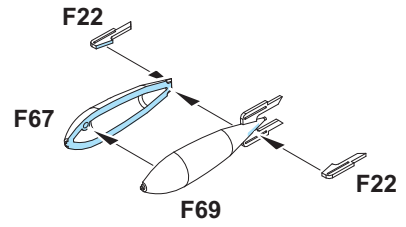
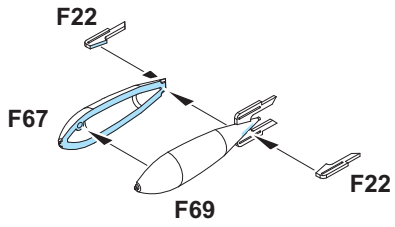



Carefully read instruction sheet before assembling. When you use glue or paint, do not use near open flame and use in well ventilated room. Keep out of reach of small children. Children must not be allowed to suck any part, or pull vinyl bag over the head.



Před započítím stavby si pečlivě prostudujte stavební návod. Při používání barev a lepidla pracujte v dobře větrané místnosti. Lepidla ani barvy nepoužívejte v blízkosti otevřeného ohně. Model není určen malým dětem, mohlo by dojít k požití drobných dílů.

## INSTRUCTION SIGNS \* INSTR. SYMBOLS \* INSTRUKTION SINNBILDEN \* SYMBOLES \* 記号の説明



OPTIONAL  
VOLBA



BEND  
OHNOUT



OPEN HOLE  
VYVRTAT OTVOR



SYMMETRICAL ASSEMBLY  
SYMETRICKÁ MONTÁŽ



REMOVE  
ODŘÍZNOUT



REVERSE SIDE  
OTOČIT



APPLY EDUARD MASK  
AND PAINT  
POUŽÍT EDUARD MASK  
NABARVIT

## PARTS



## DÍLY



## TEILE



## PIÈCES



## 部品

## PLASTIC PARTS

A&gt;

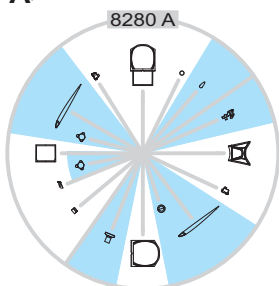

D&gt;

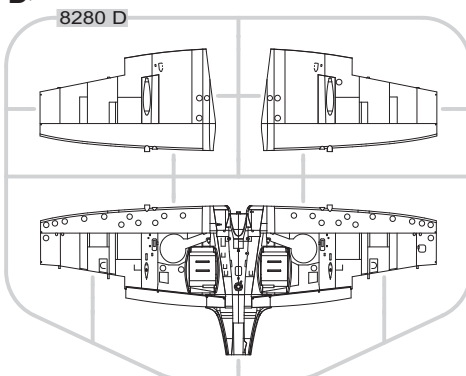

E&gt;

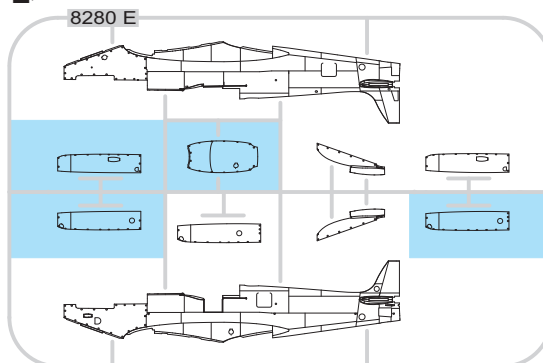

F&gt;

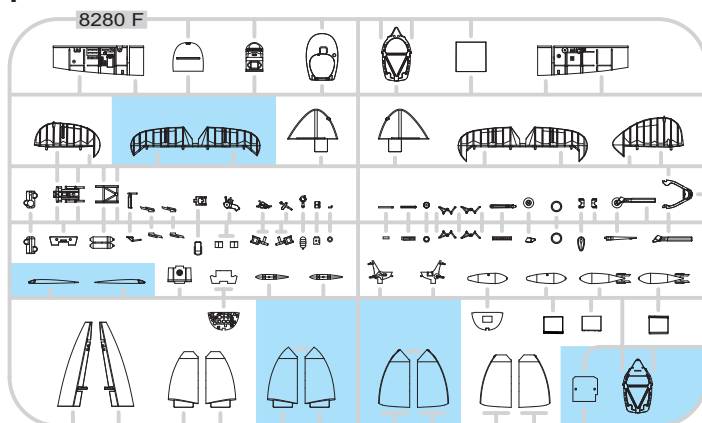

G&gt;

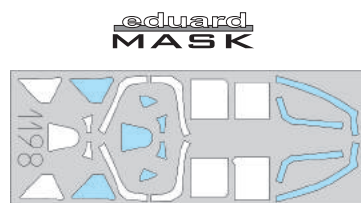
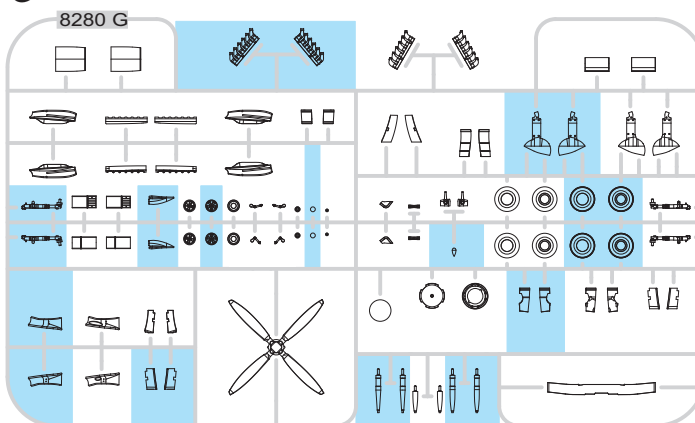

## PE - PHOTO ETCHED DETAIL PARTS

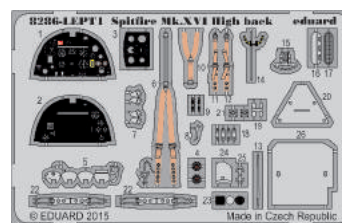

-Parts not for use. -Teile werden nicht verwendet. -Pièces à ne pas utiliser. -Tyto díly nepoužívejte při stavbě. - 使用しない部品

## COLOURS



## BARVY



## FARBEN



## PEINTURE



## 色

GSI Creos (GUNZE)		
AQUEOUS	Mr.COLOR	
H 4	C4	YELLOW
H 11	C62	FLAT WHITE
H 12	C33	FLAT BLACK
H 13	C3	FLAT RED
H 33	C81	RUSSET
H 77	C137	TIRE BLACK
H 90	C47	CLEAR RED
H 94	C138	CLEAR GREEN
	C361	MEDIUM SEAGRAY

AQUEOUS	Mr.COLOR	
	C362	OCEAN GRAY
	C363	DARK GREEN
	C364	AIRCRAFT GRAY-GREEN
	C368	SKY
Mr.METAL COLOR		
	MC214	DARK IRON
	MC218	ALUMINIUM
Mr.COLOR SUPER METALLIC		
	SM06	CHROME SILVER

# Mk.XVI High Back

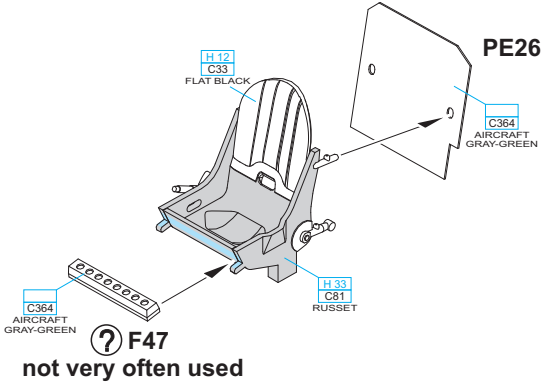
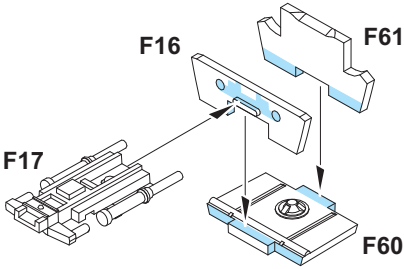
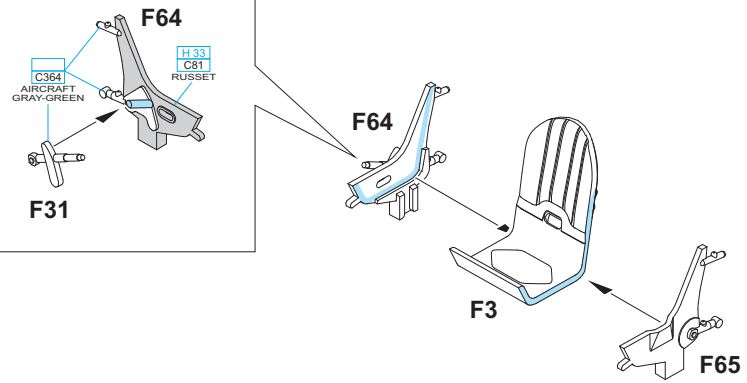
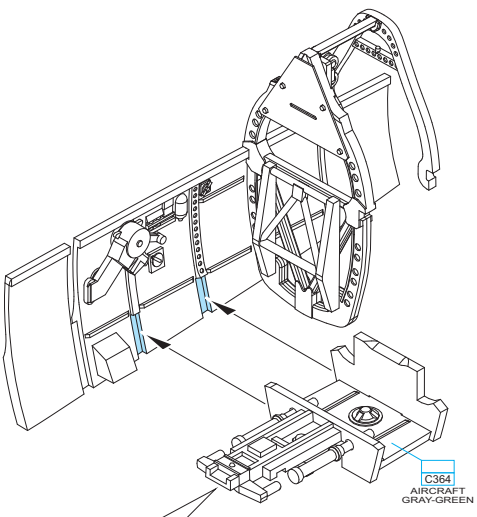
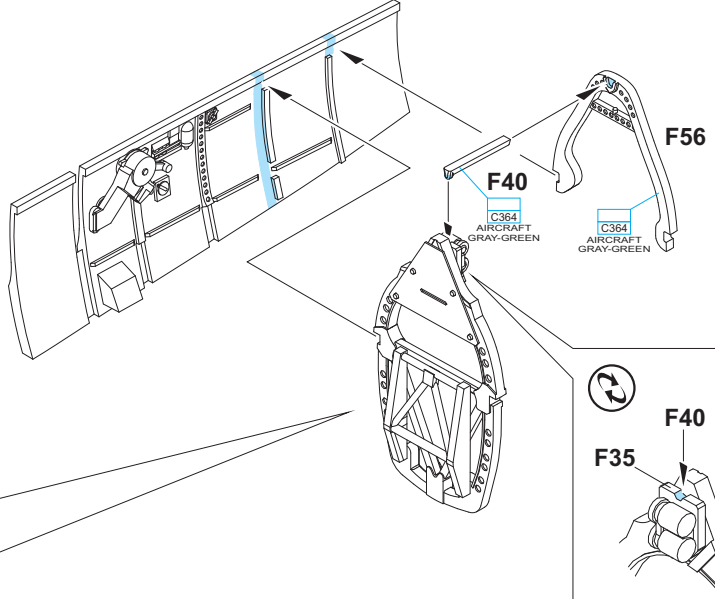
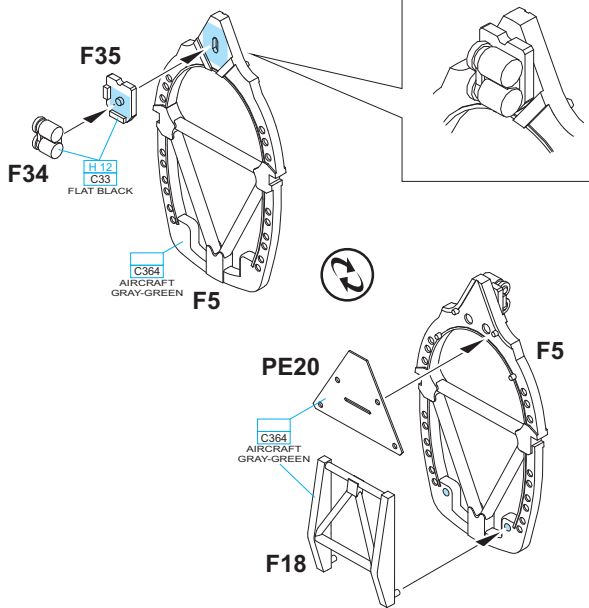
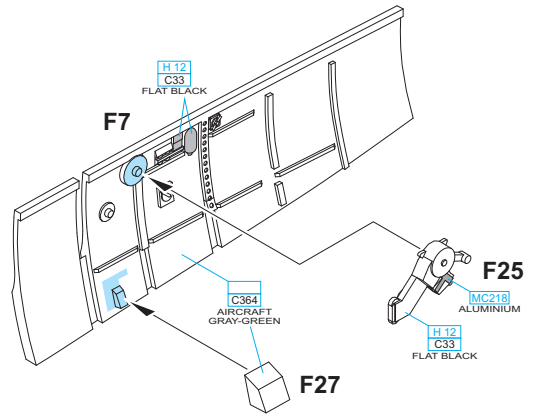
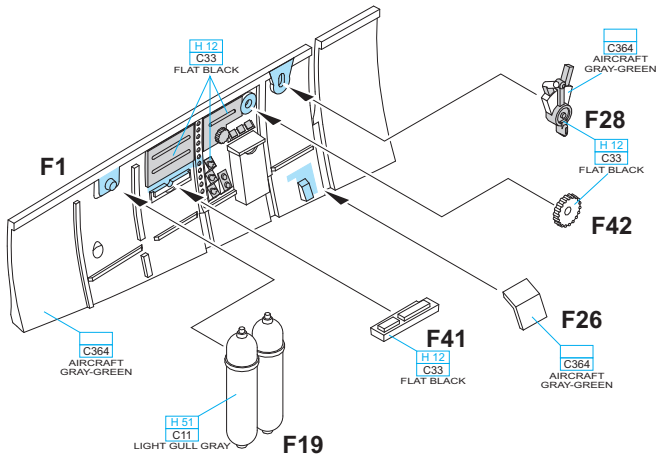

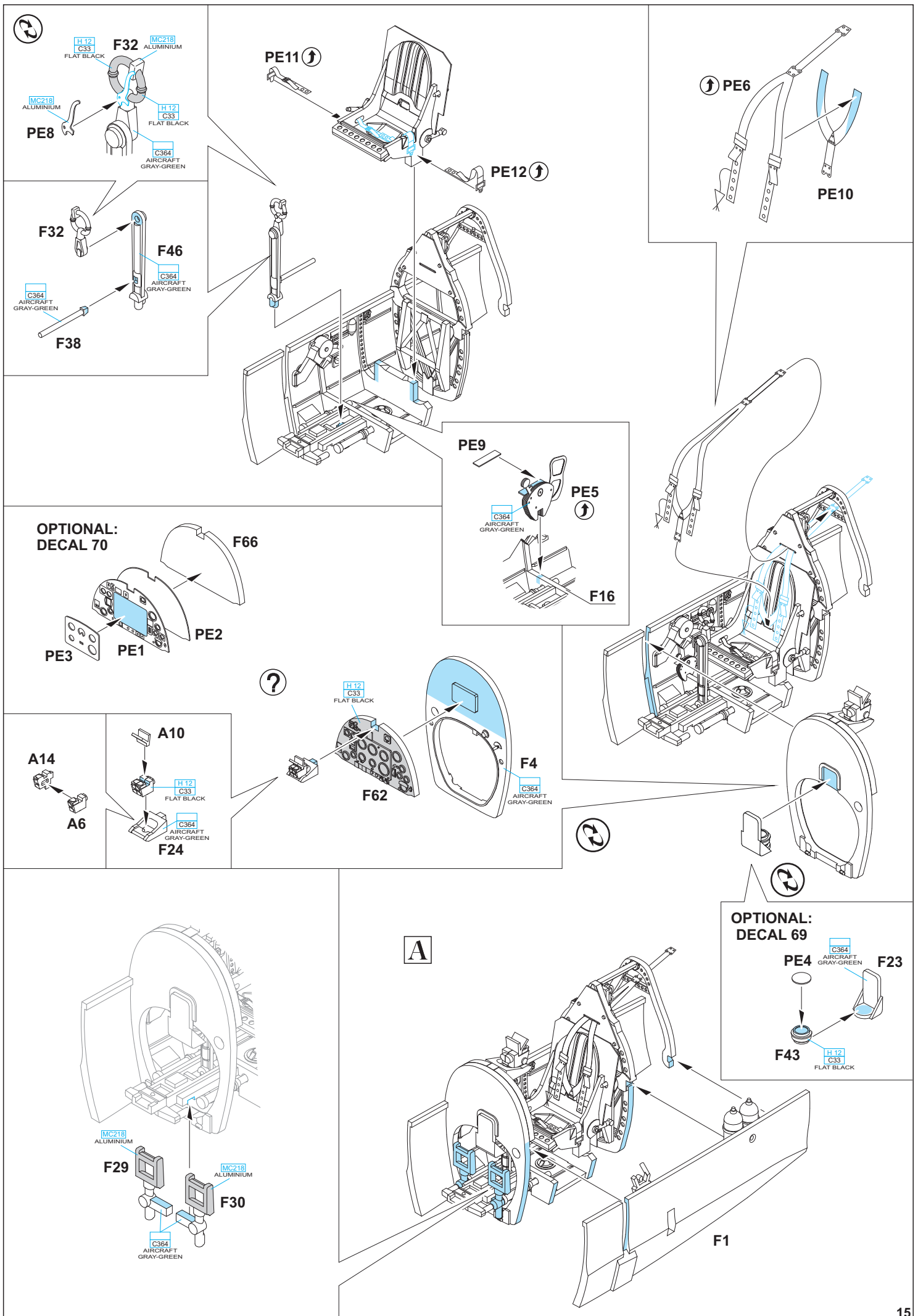

FOR CLOSED CANOPY ONLY

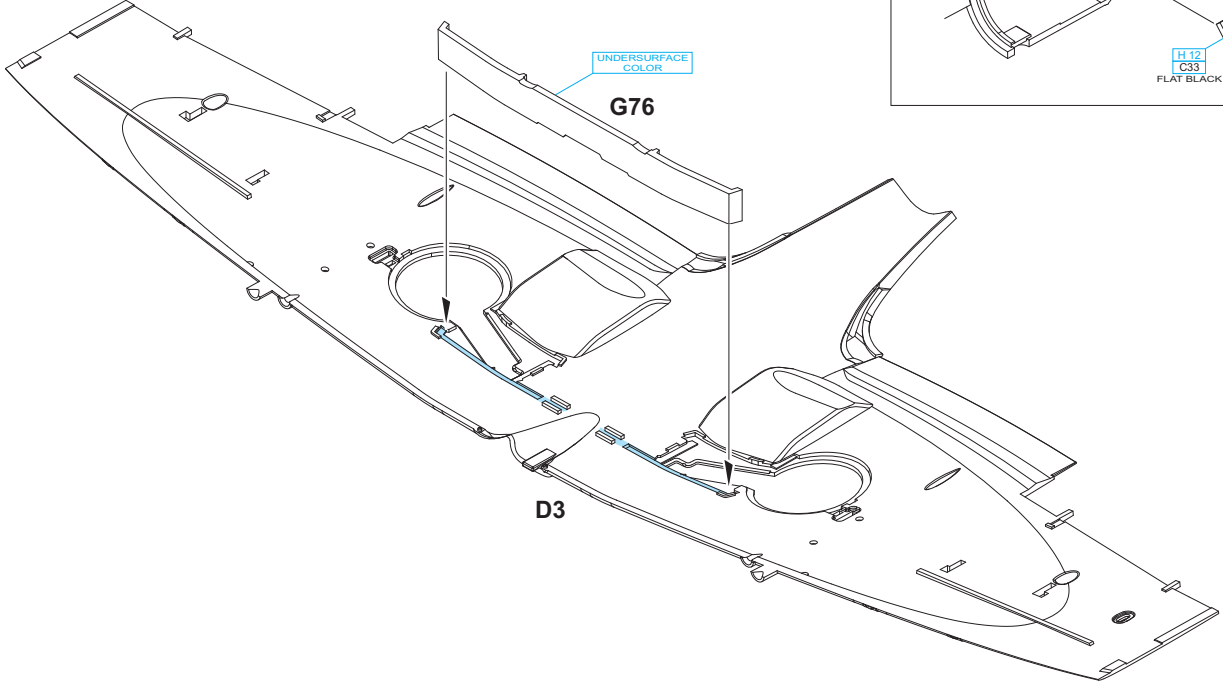
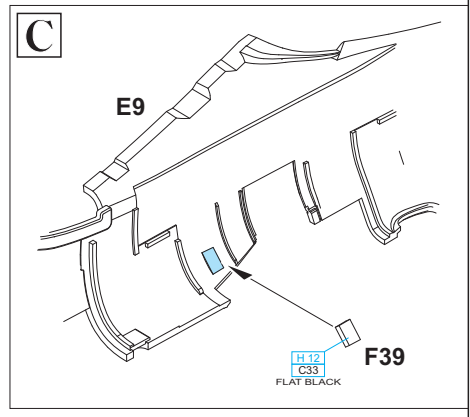
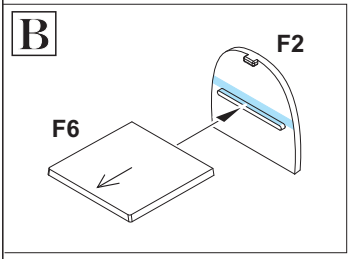
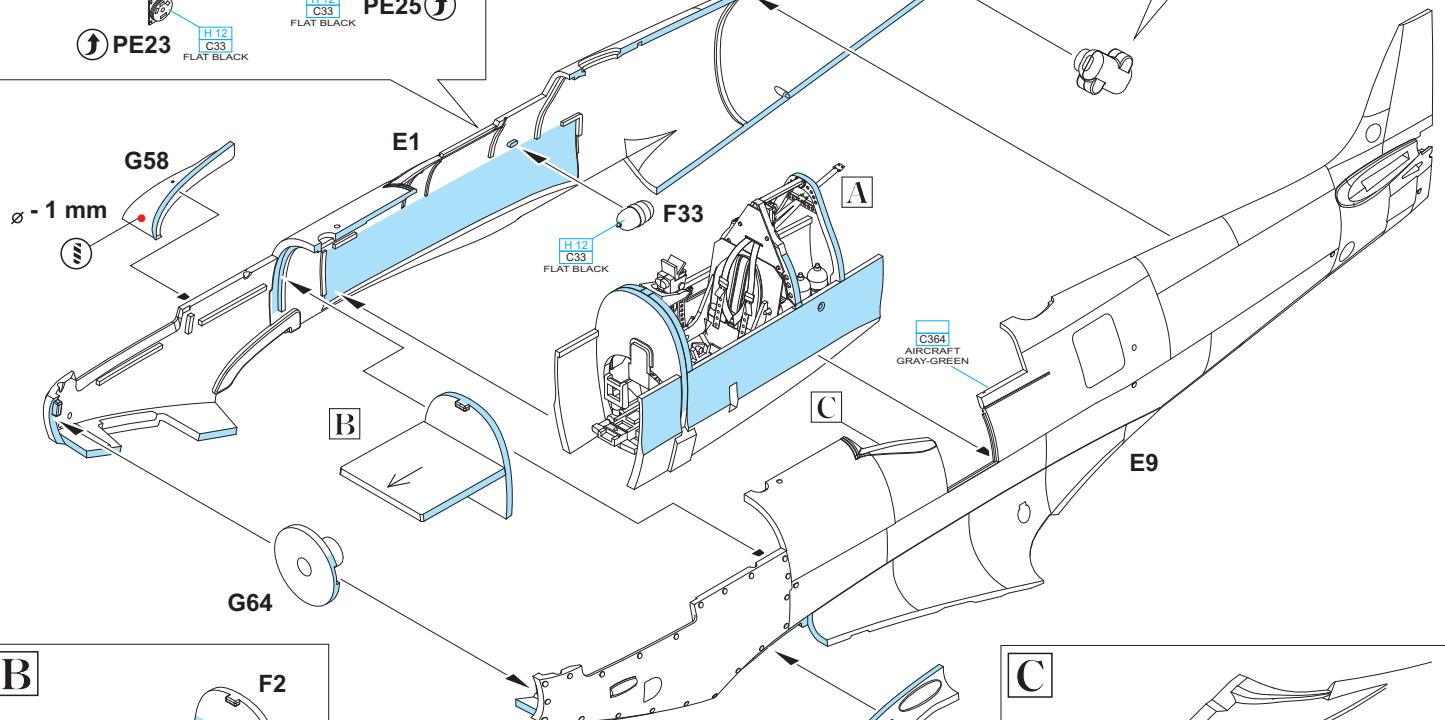
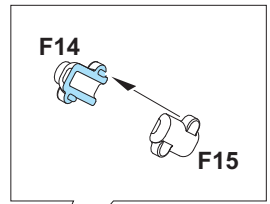
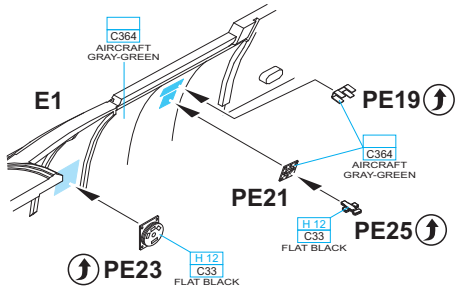
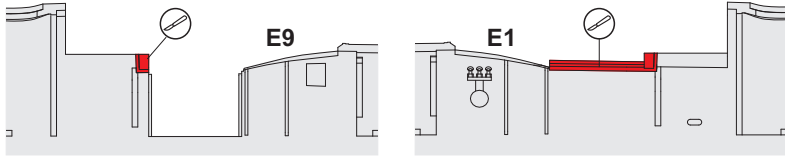



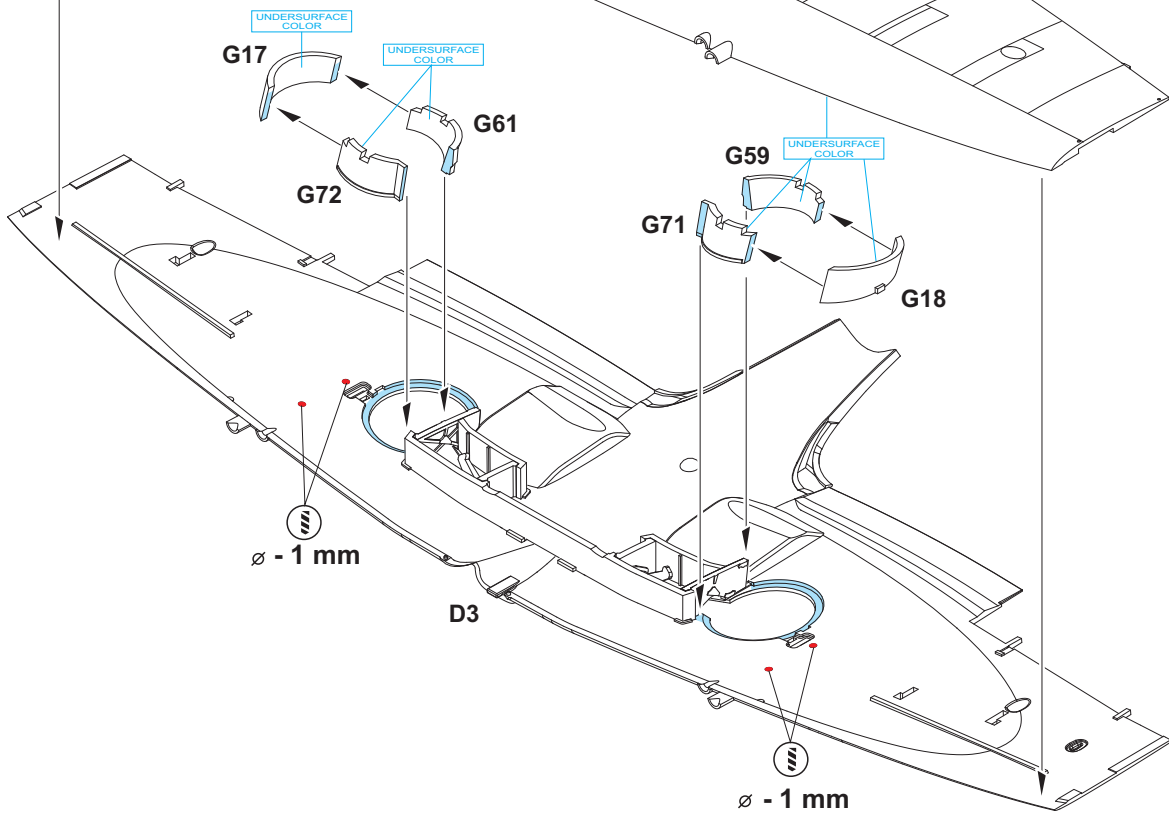
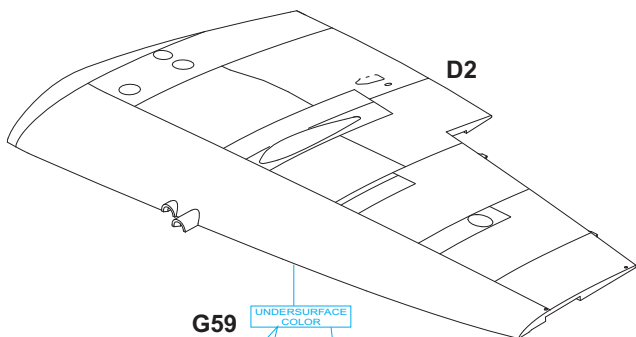
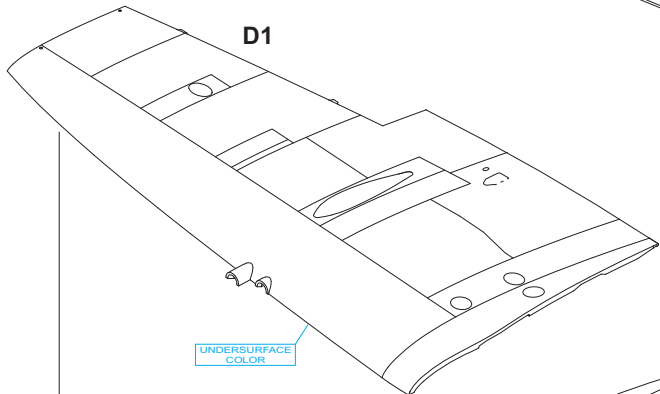
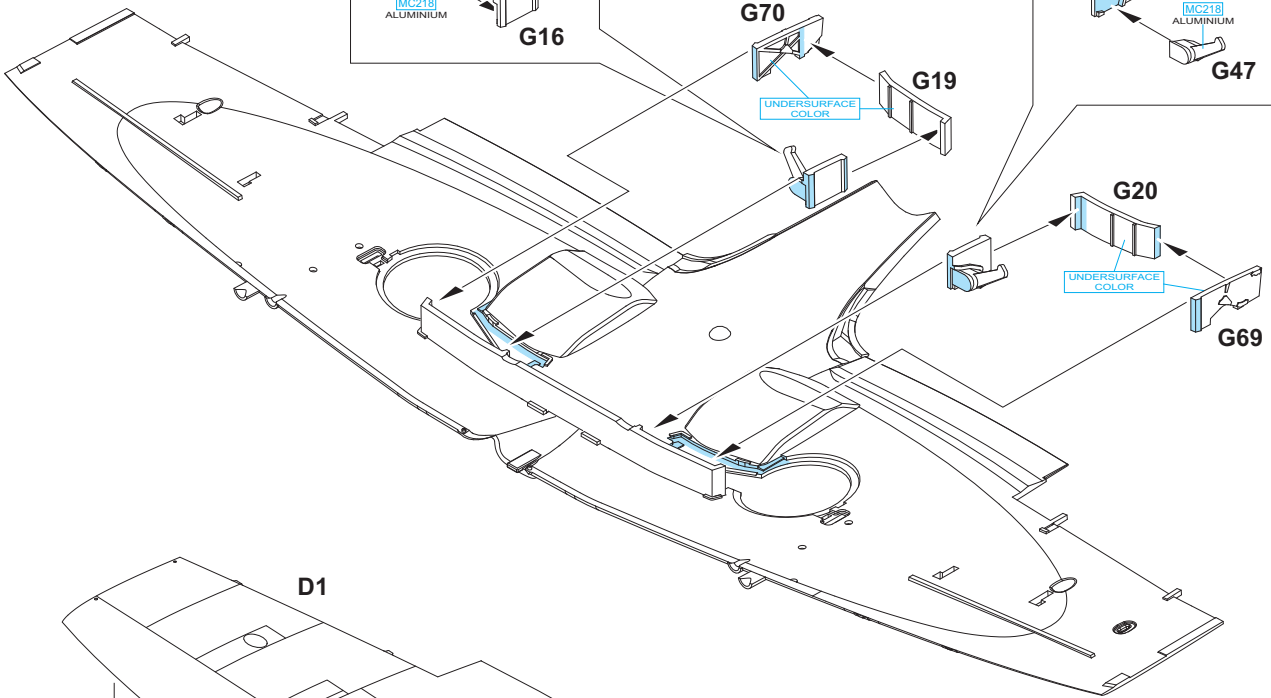
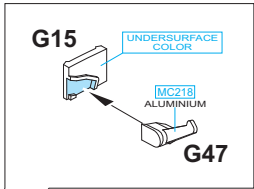
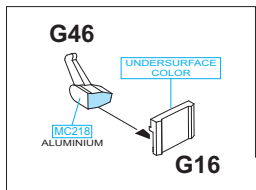

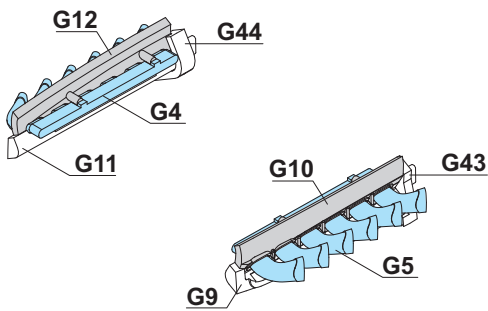
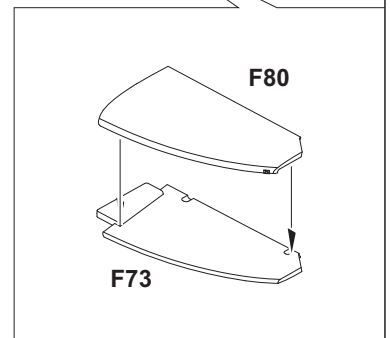
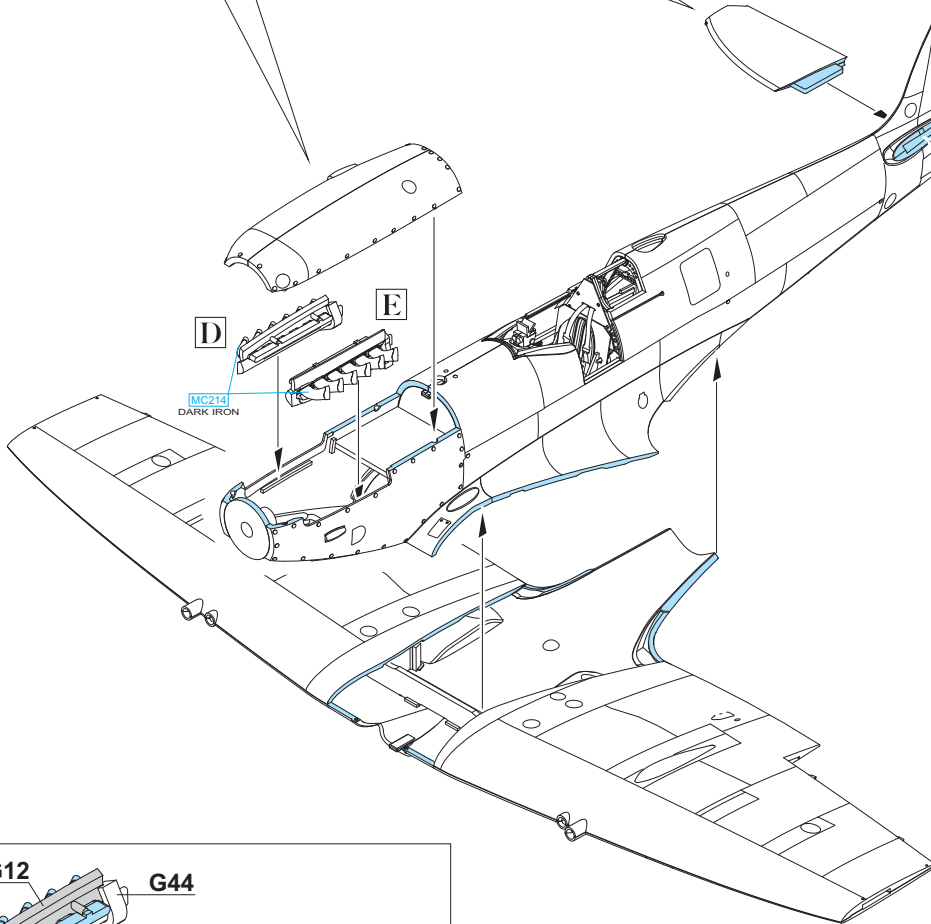
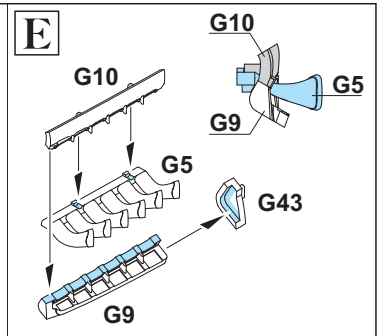
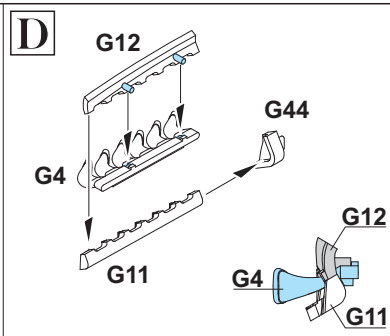
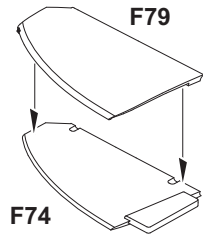
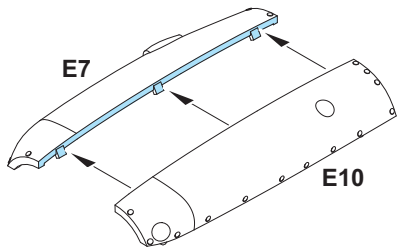

GLUE PARTS F52 & F53  
ONE BY ONE

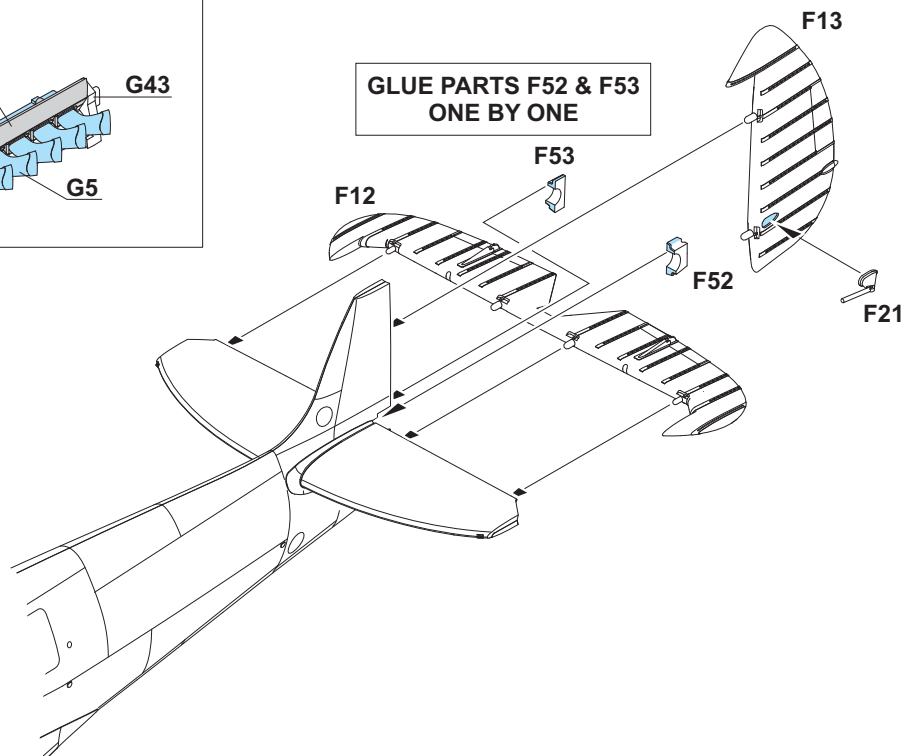

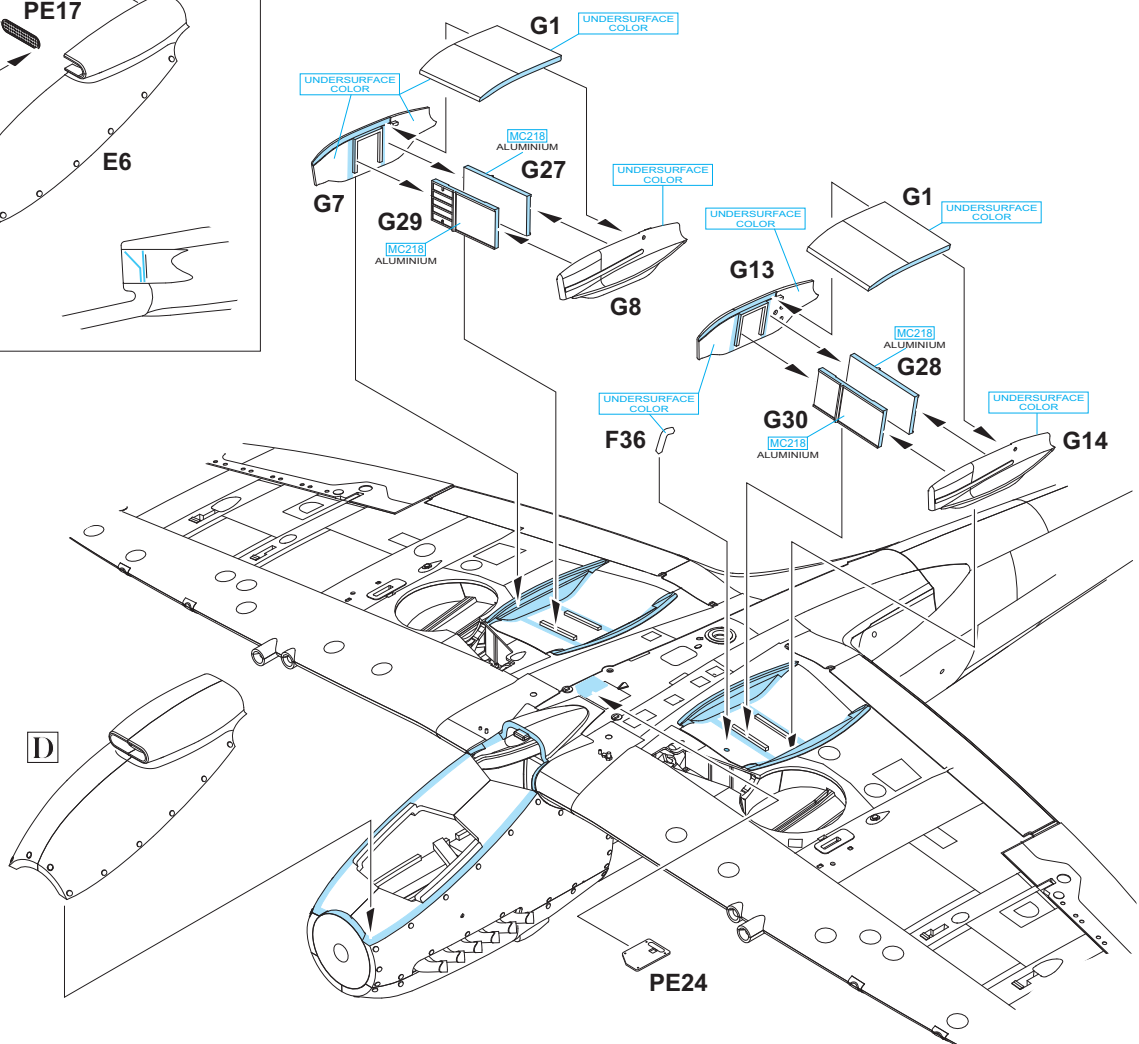
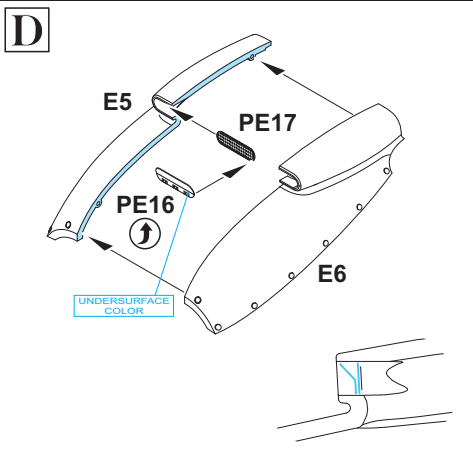
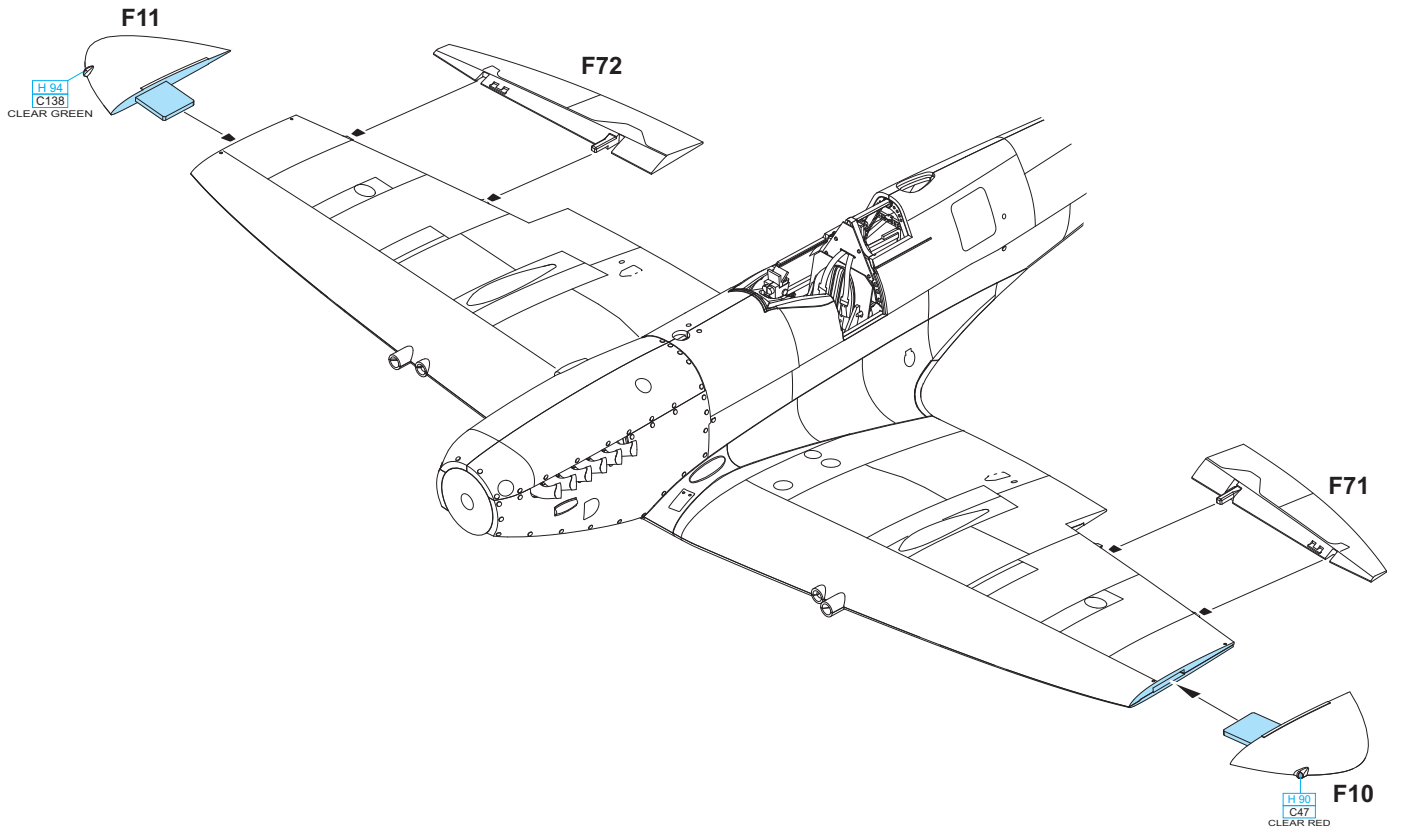

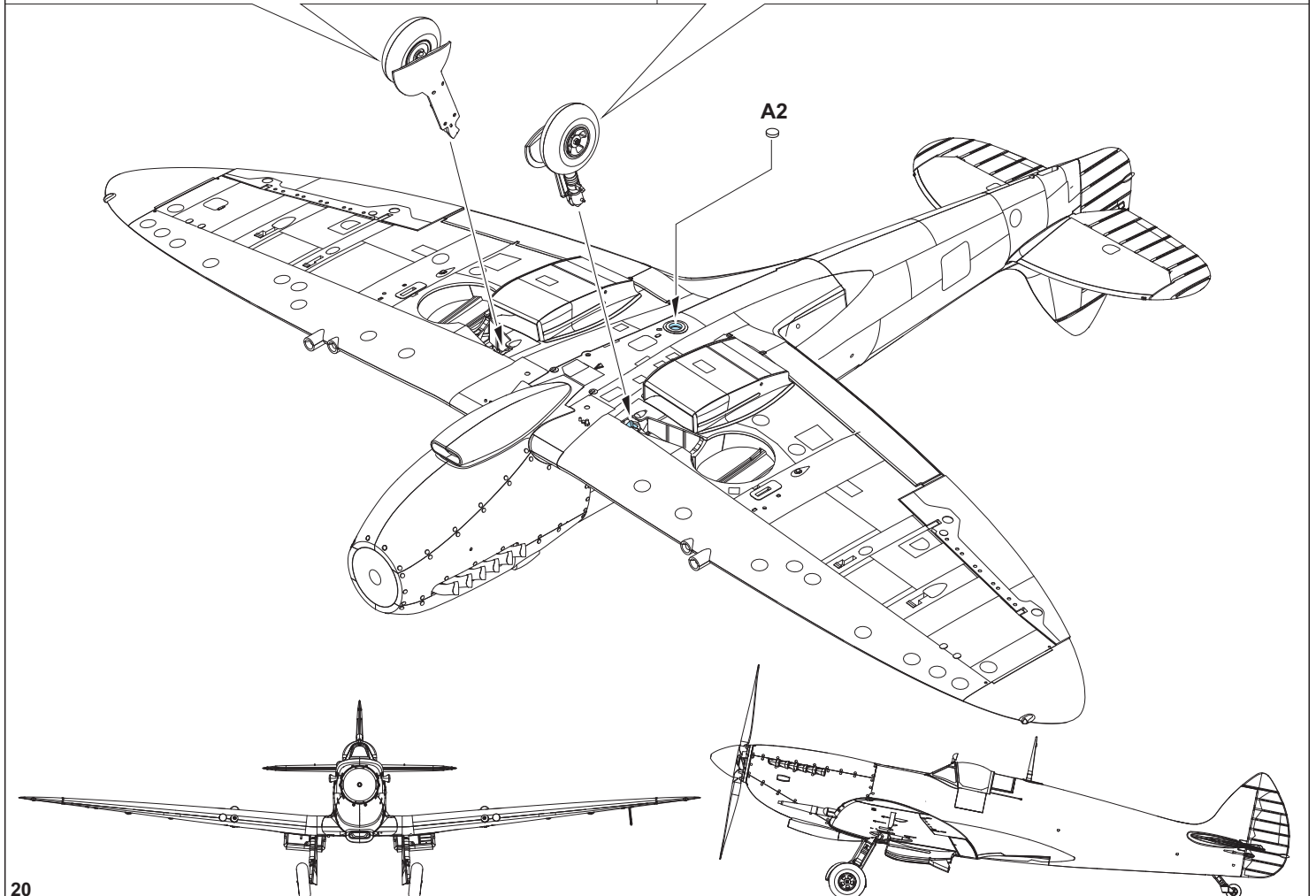
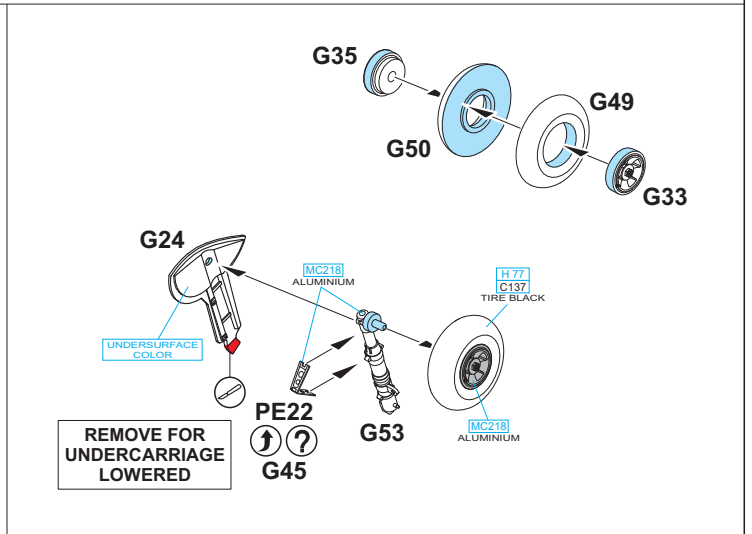
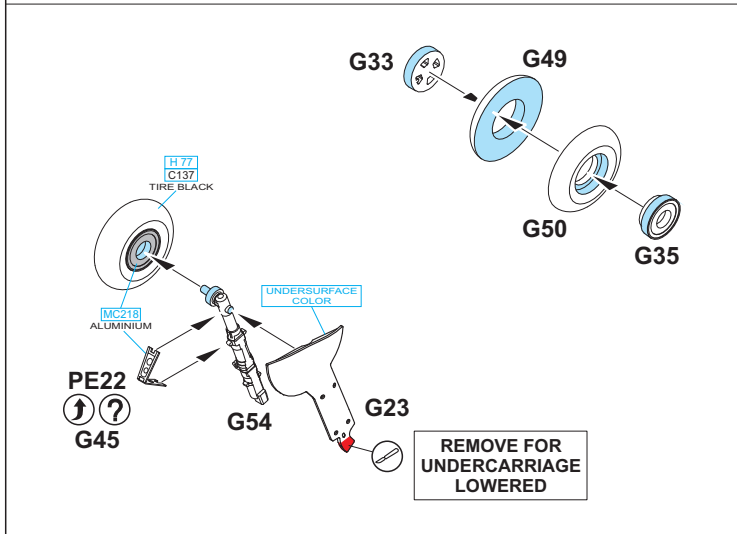
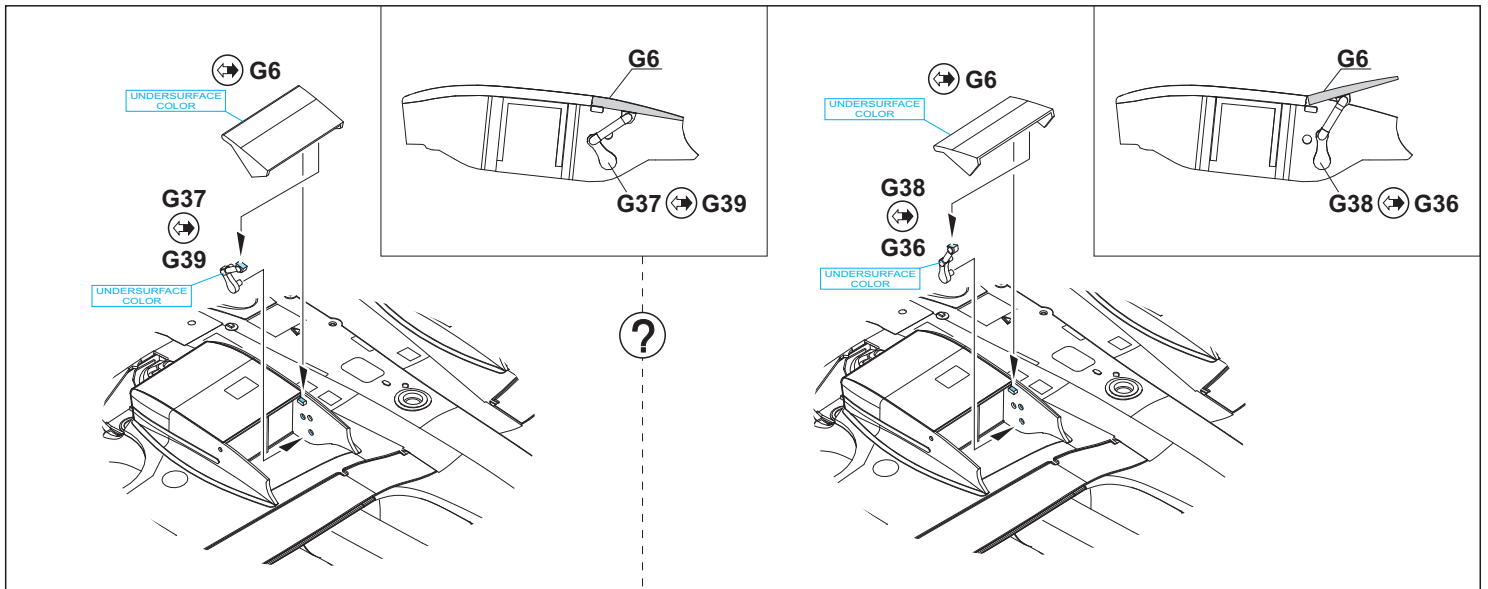

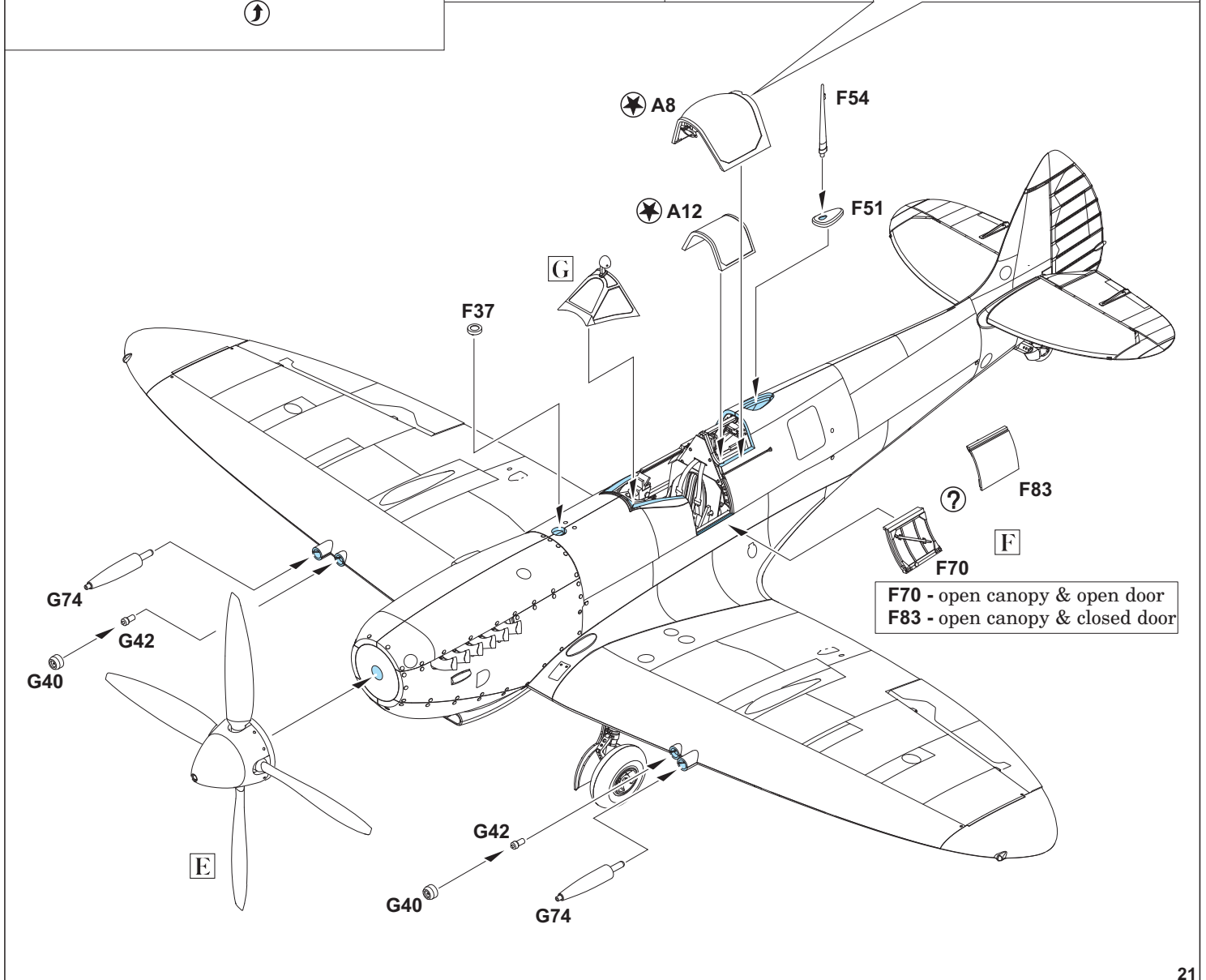
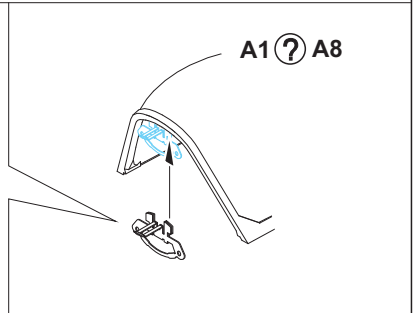
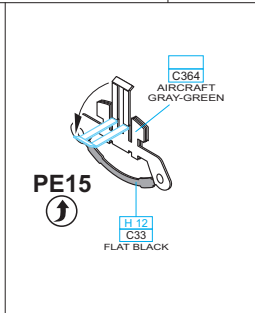
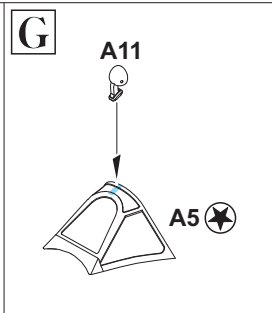
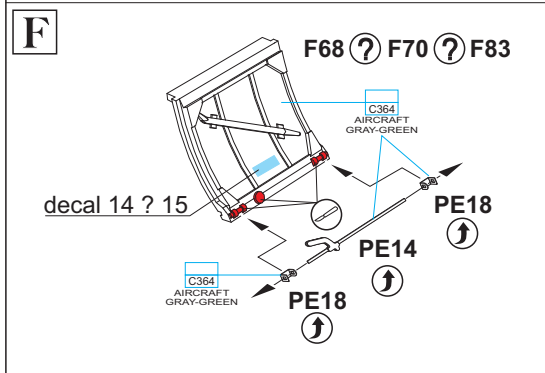
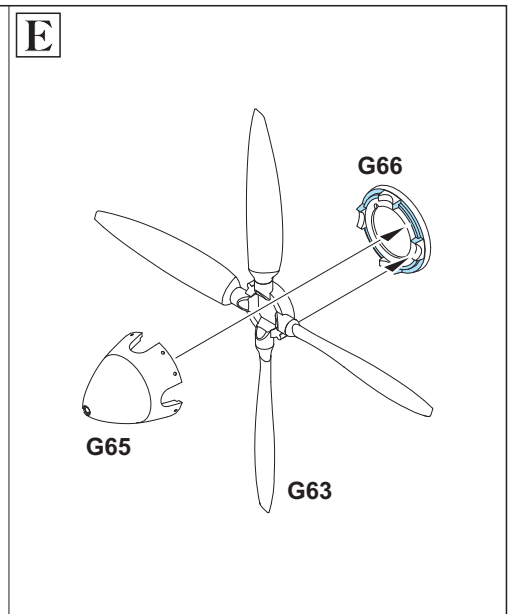
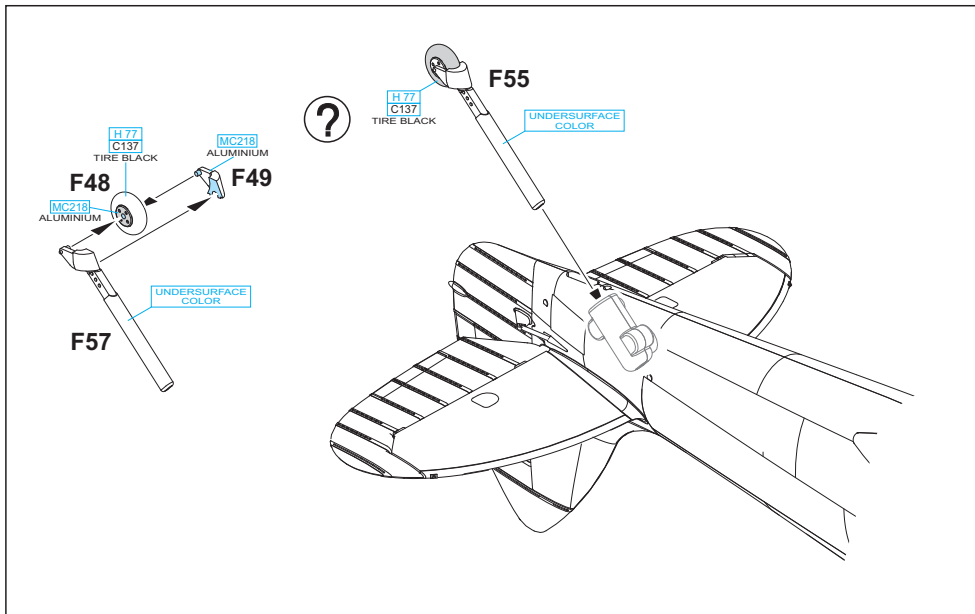

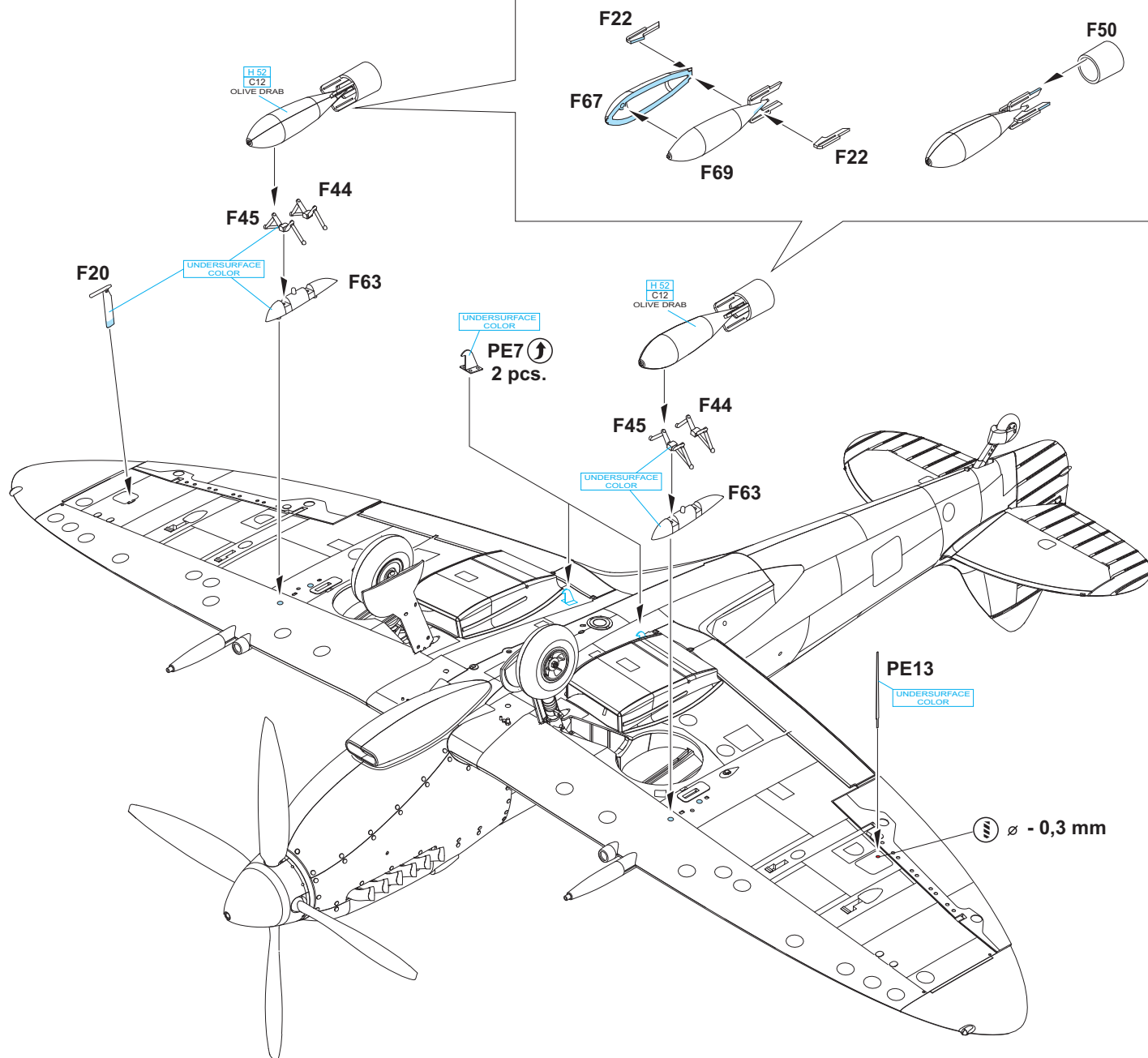
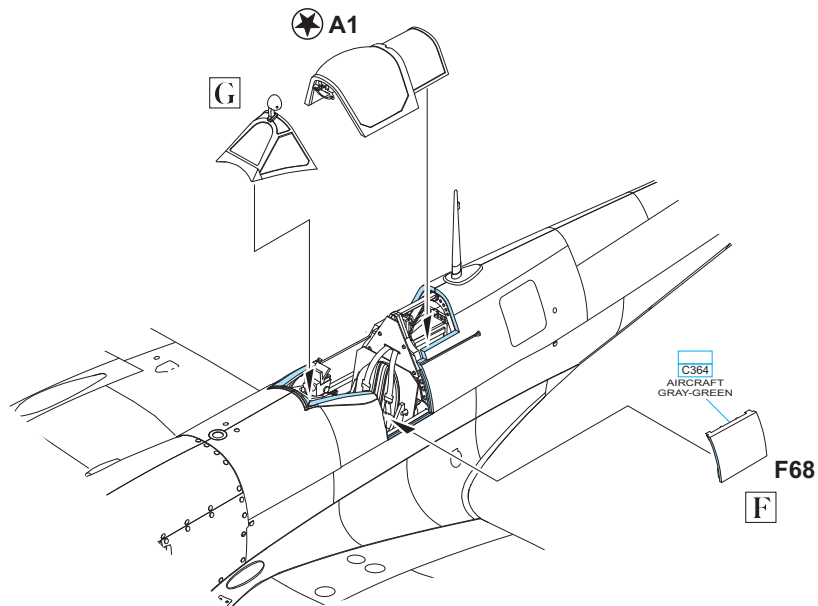

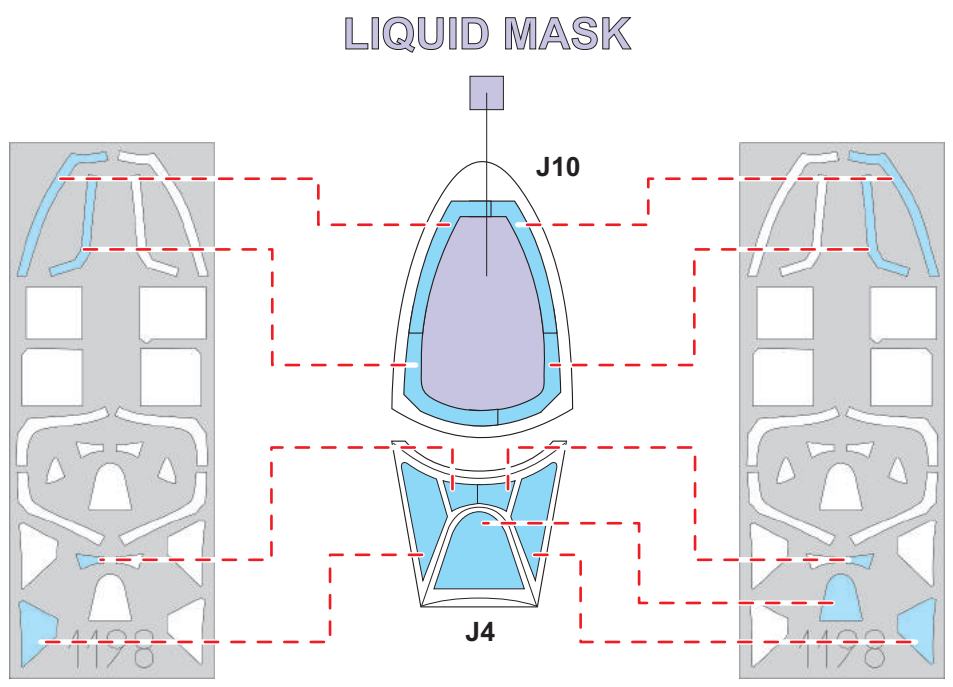
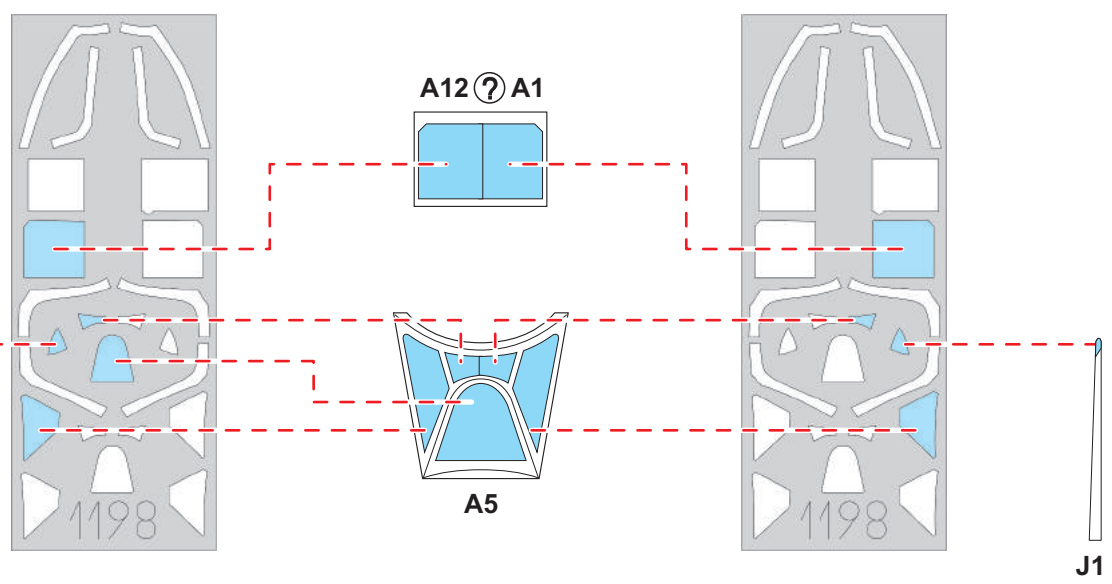
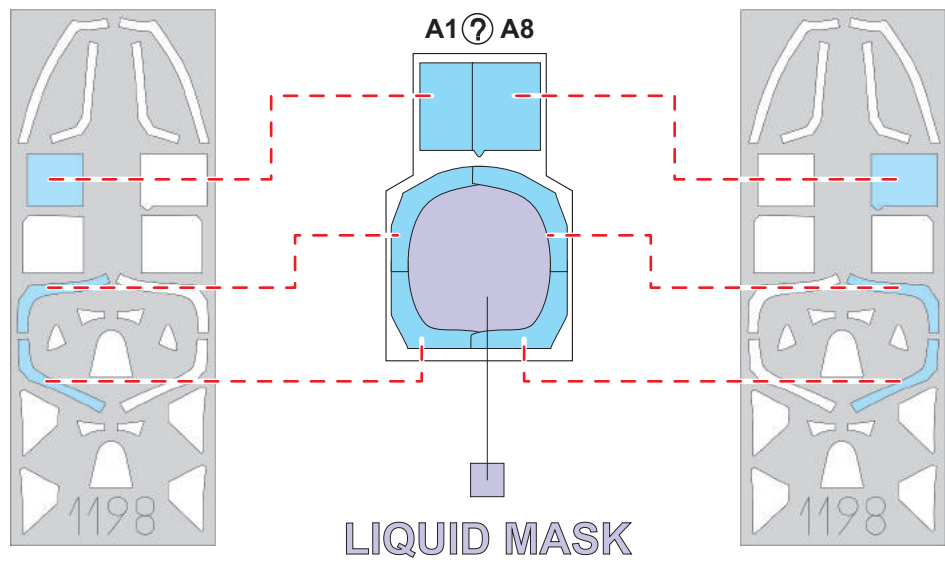

# A TD341, No. 443 Squadron, Uetersen airfield, Germany, August, 1945

No. 443 Squadron RCAF had a Hornet painted in the unit crest along with the motto 'Our Sting is Death'. The colors on the spinner thus corresponded with the name of the unit. The squadron flew Spitfire Mk.XVIs and stayed in Uetersen until its disbandment on May 15, 1946. The Sky band on the tail was overpainted with camouflage colors.

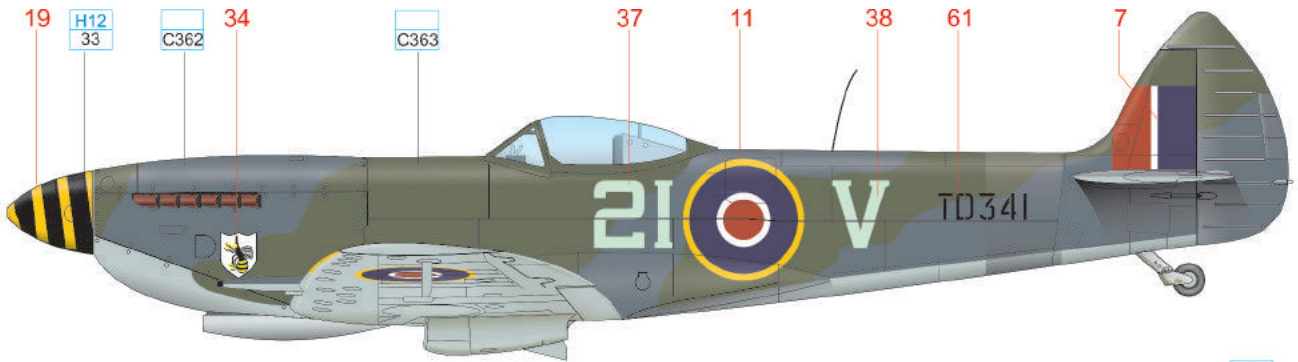

ČESKOU VERZI TEXTU NALEZNETE NA  
[www.eduard.com/s/1198](http://www.eduard.com/s/1198)

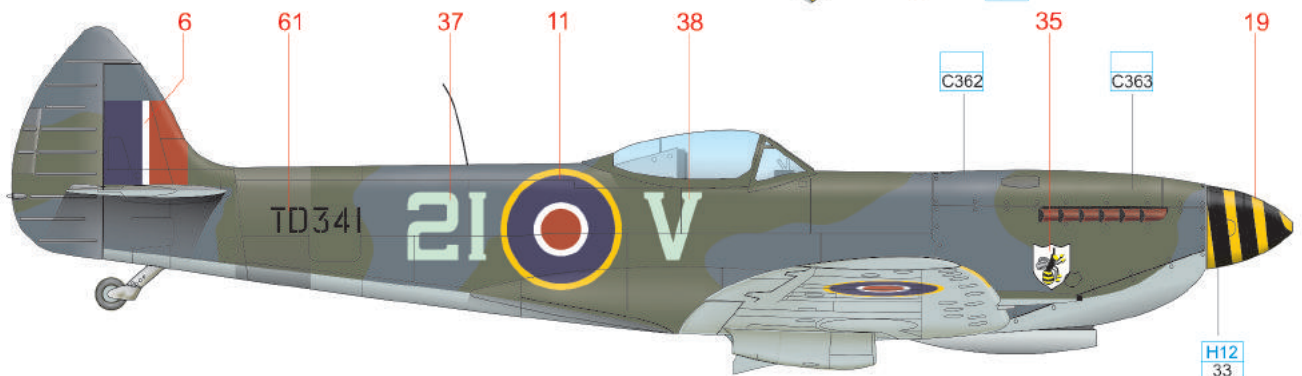
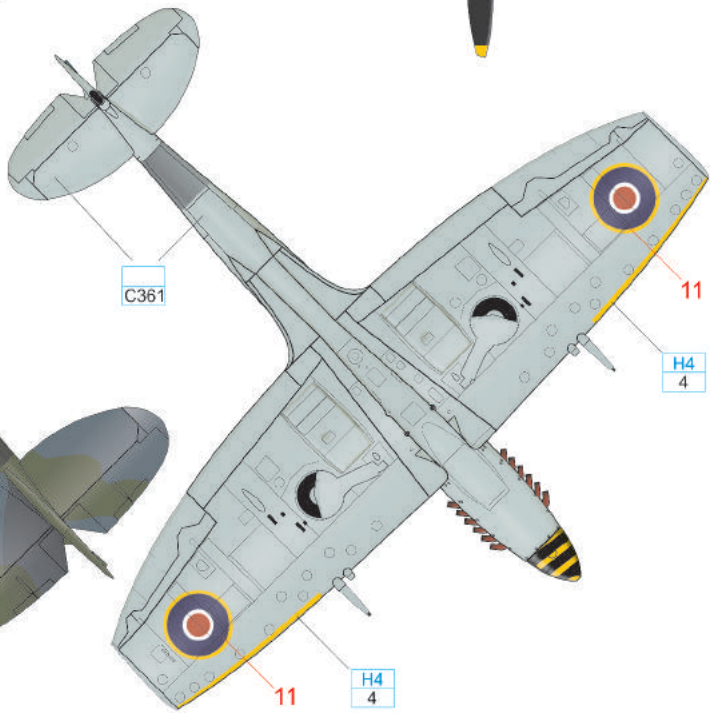
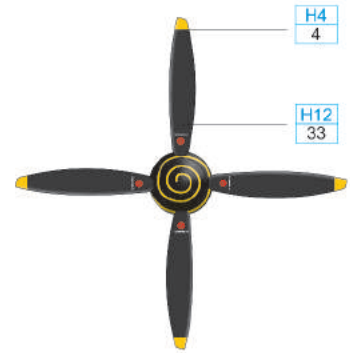
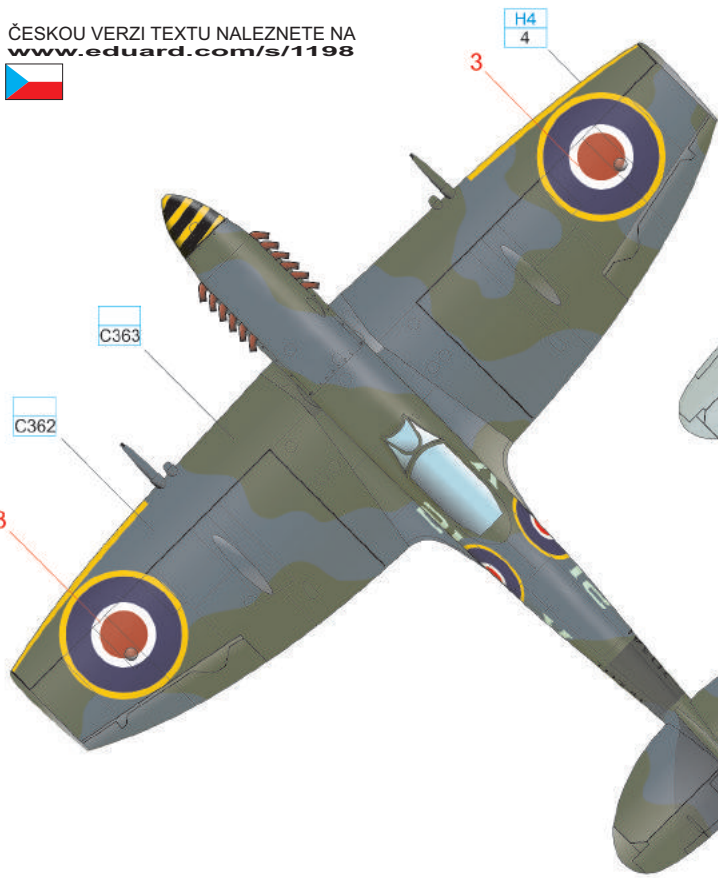

YELLOW	H4 4	MEDIUM SEA GRAY	C361	OCEAN GRAY	C362	DARK GREEN	C363	BLACK	H12 33
--------	---------	-----------------	------	------------	------	------------	------	-------	-----------



# B TB900, No. 349 Squadron, Wunstorf, Germany, Summer, 1945

TB900 was built by Vickers Armstrong at Castle Bromwich and given the name Winston Churchill in honour of the Prime Minister. It was used operationally by No. 127 Squadron from April 15, 1945. It subsequently was taken on strength by No. 349 Squadron on April 26, 1945. It became the personal mount of S/Ldr. Raymond Lallemand, the CO of No. 349 Squadron. TB900 was stripped of its paint to become one of two overall silver painted "presentation" aircraft of the squadron in May, 1946 but crashed shortly after the repaint.

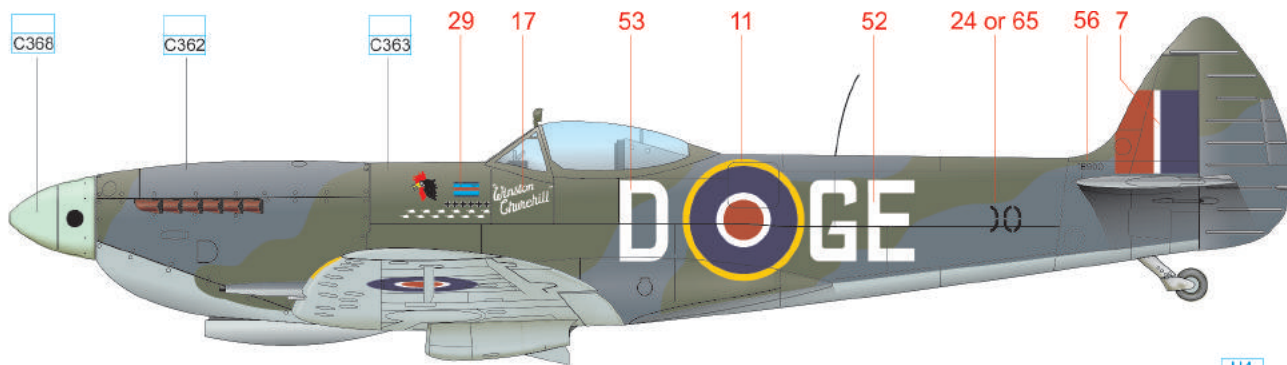

ČESKOU VERZI TEXTU NALEZNETE NA [www.eduard.com/s/1198](http://www.eduard.com/s/1198)

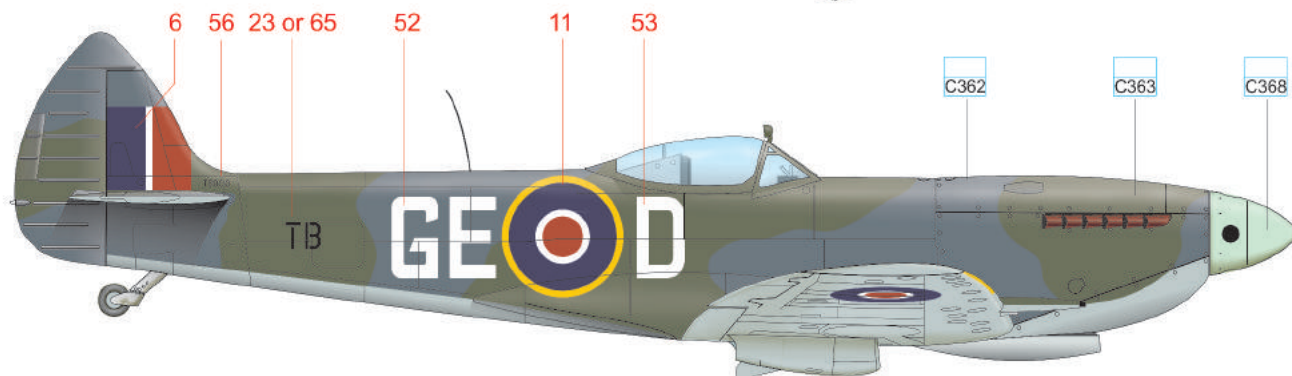
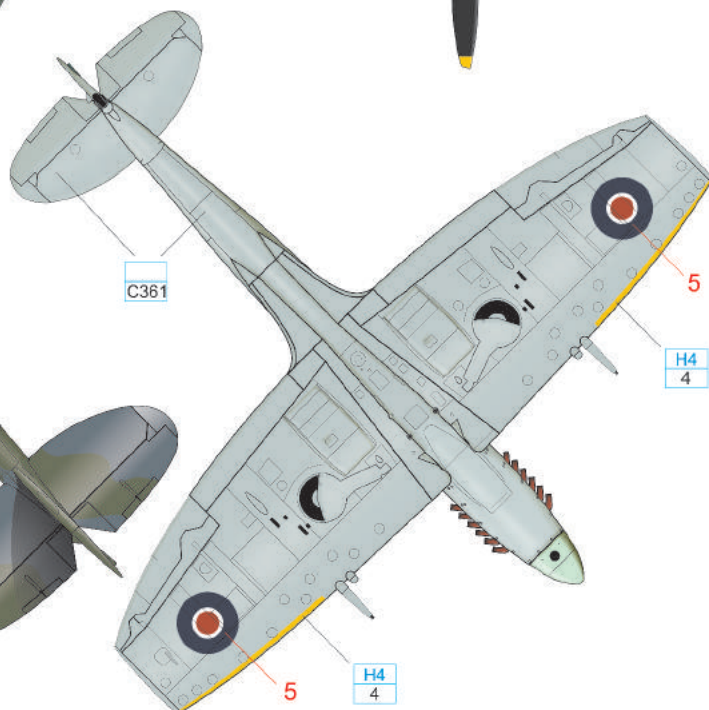
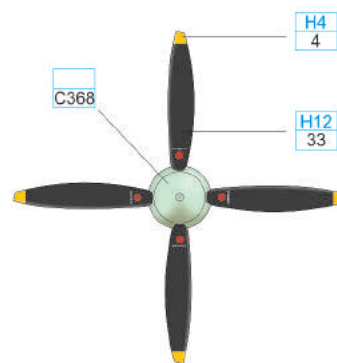
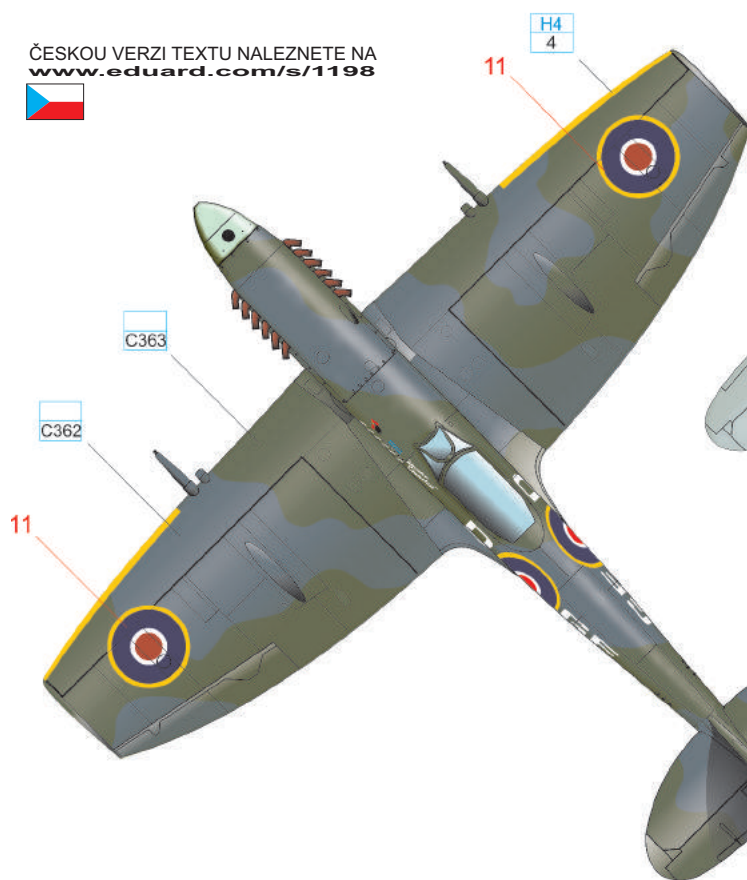

YELLOW	H4 4	SKY	C368	MEDIUM SEA GRAY	C361	OCEAN GRAY	C362	DARK GREEN	C363	BLACK	H12 33
--------	---------	-----	------	--------------------	------	------------	------	------------	------	-------	-----------

# C TD240, Flown by S/Ldr. Boleslaw Kaczmarek, CO of No. 302 Squadron, Varrelsbuch Air Field, Germany, Summer, 1945

This aircraft was formerly flown by G/C Gabszewicz, the CO of No. 131 Wing. The boxing dog was his personal artwork. In the middle of June, 1945, the aircraft was inherited by S/Ldr. Boleslaw Kaczmarek, the CO of No. 302 Squadron and Gabszewicz's personal emblem was retained on the aircraft, with the female name Janetka being added. Note the squadron badge below the windscreen.

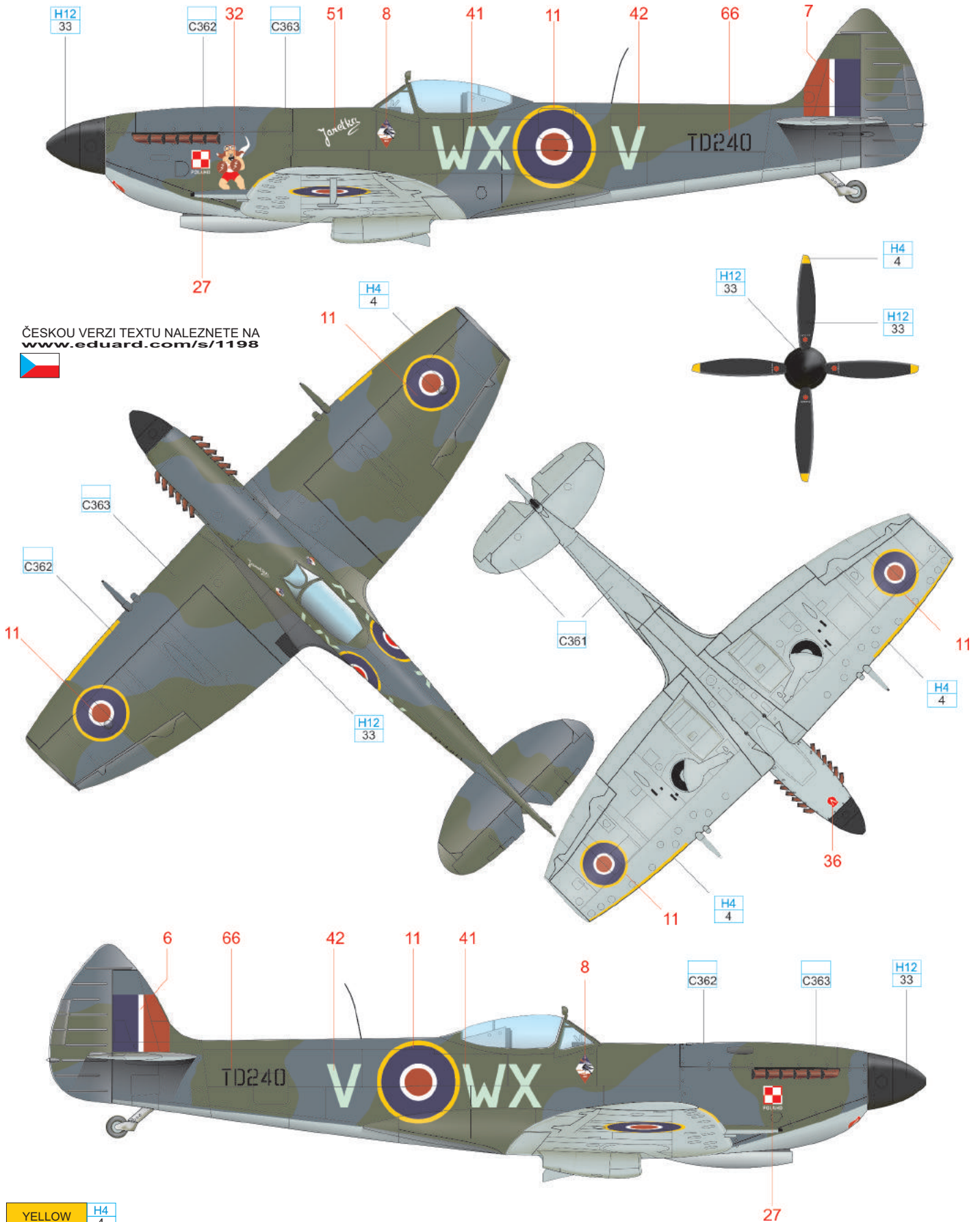

ČESKOU VERZI TEXTU NALEZNETE NA [www.eduard.com/s/1198](http://www.eduard.com/s/1198)



YELLOW	H4 4
MEDIUM SEA GRAY	C361
OCEAN GRAY	C362
DARK GREEN	C363
BLACK	H12 33

# D SL721, Flown by AVM Sir James Robb, 1948

SL721 was delivered to No. 8 Maintenance Unit on August 27, 1945. It was subsequently flown by the Fighter Command Communication Squadron at Northolt Air Base. In February, 1948, it was operated by Metropolitan Communications Squadron. It served as the personal aircraft of AVM Sir James Robb, a WWI fighter ace with seven kills to his credit. The unusual PRU Blue camouflage was adorned with the Air Vice Marshall's pennant and three stars. This Spitfire is currently preserved and was flown during the Reno Air Race. One of its pilots was Canadian Jerry Billing.

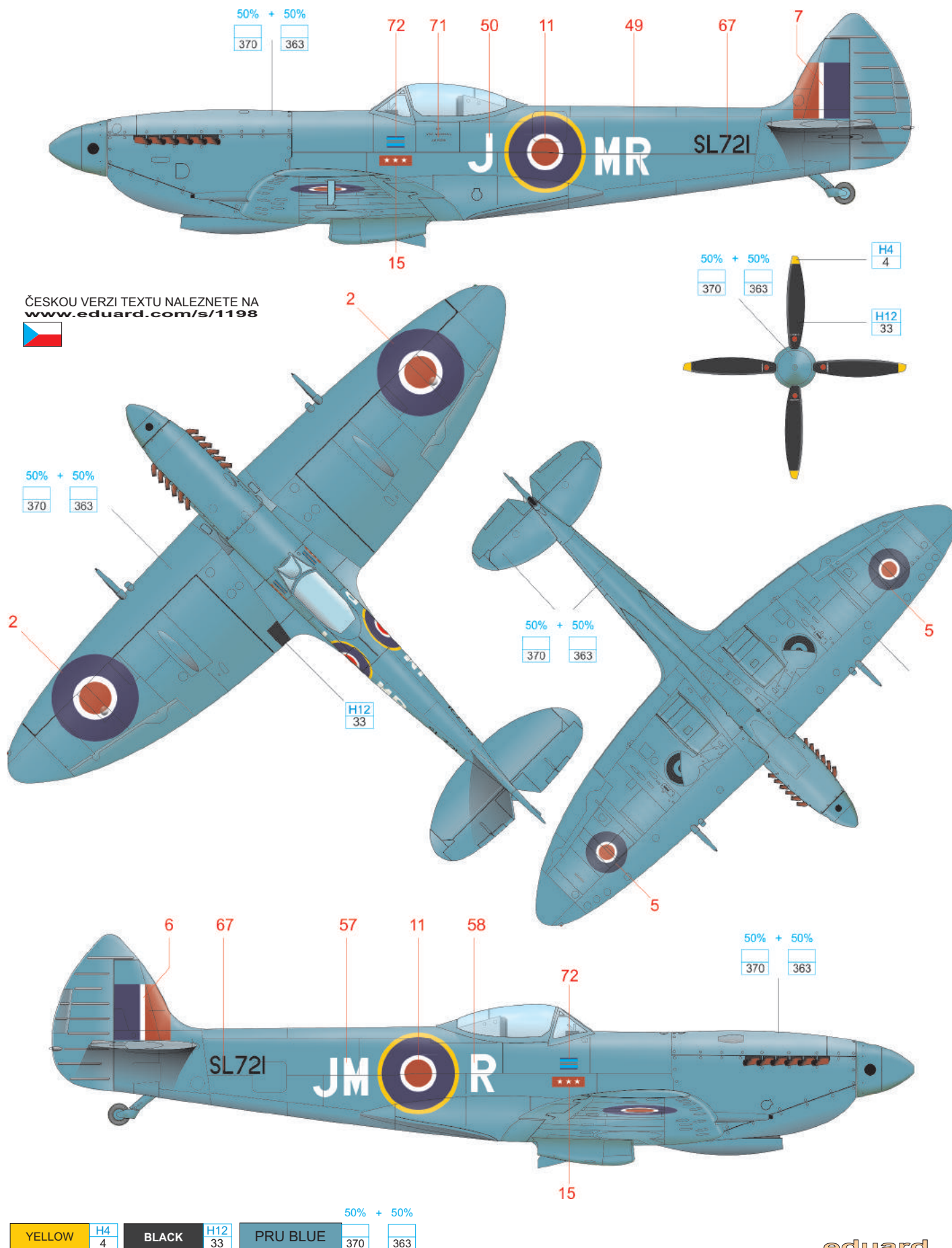

ČESKOU VERZI TEXTU NALEZNETE NA [www.eduard.com/s/1198](http://www.eduard.com/s/1198)



50% + 50%  
370 363

50% + 50%  
370 363

50% + 50%  
370 363

50% + 50%  

YELLOW	H4 4	BLACK	H12 33	PRU BLUE	370	363
--------	---------	-------	-----------	----------	-----	-----

# E SL718, No. 612 Squadron RAuxAF, Cooper Air Race, Elmdon Air Base, July, 1949

One of the aircraft that participated in the 1949 Cooper Air Race was Spitfire Mk. XVI SL718. The small bulge on the wings upper surface was created to accommodate the three-spoke undercarriage wheels. Black and white photos show reversed colors in the fin flash. The color of the fuselage band is not clear but was light blue in all probability.

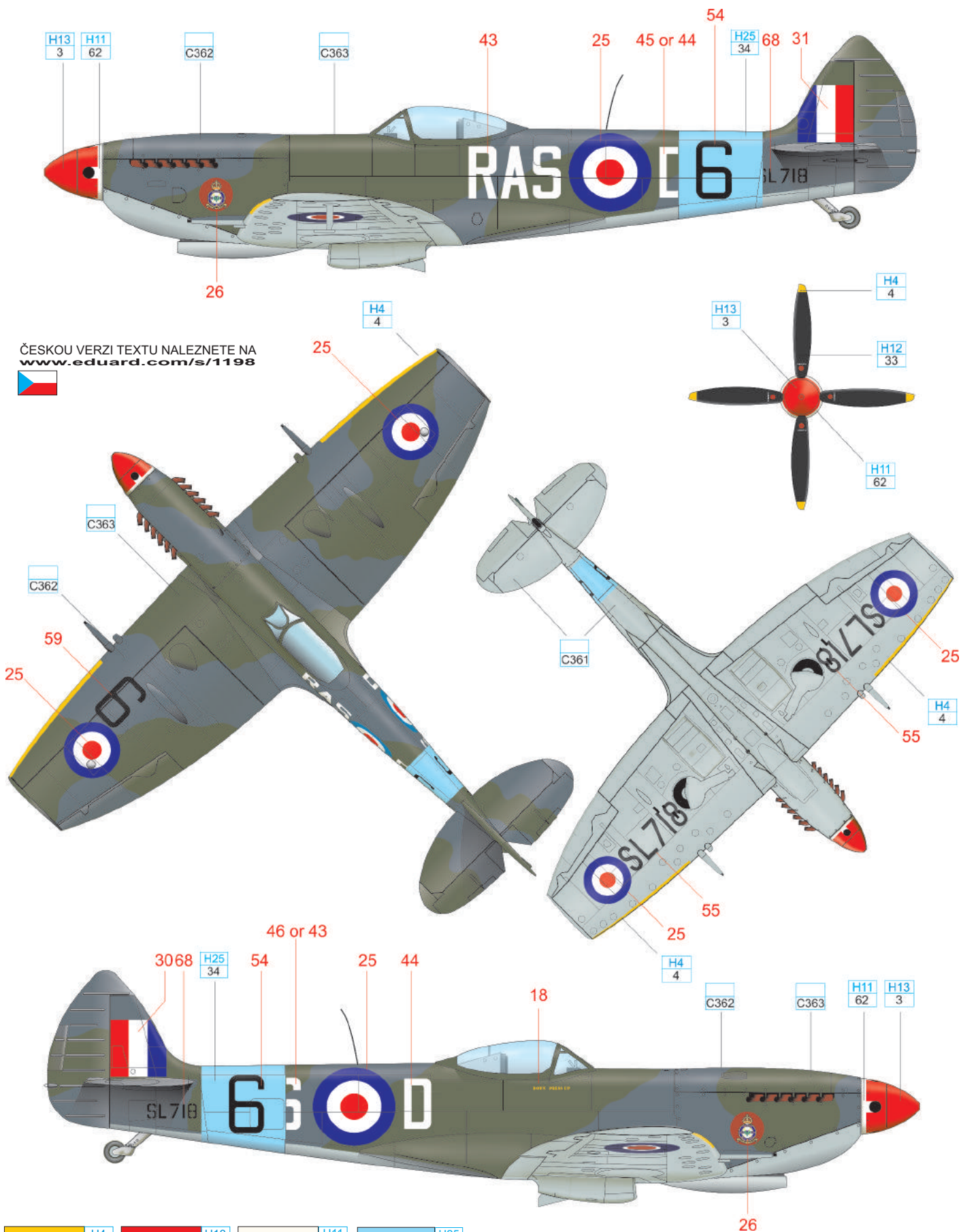

ČESKOU VERZI TEXTU NALEZNETE NA  
[www.eduard.com/s/1198](http://www.eduard.com/s/1198)



YELLOW	H4 4	RED	H13 3	WHITE	H11 62	SKY BLUE	H25 34
MEDIUM SEA GRAY	C361	OCEAN GRAY	C362	DARK GREEN	C363	BLACK	H12 33

# F RR27, Flown by S/Ldr. Otto Smik, CO of No. 127 Squadron, Grimbergen Airfield, Belgium, November, 1944

Otto Smik was given command of No. 127 Squadron on November 13, 1944 and became the last of three Czechoslovak pilots who commanded British squadrons in WWII. He was killed by AA fire during an attack on a railway station in Zwolle, Belgium on November 28, 1945. He was credited with eleven kills and three V-1s destroyed at the time of his death. He flew Spitfire RR227 on that fateful flight (old theories stated RR229). The appearance of this aircraft is not photographically documented but research conducted by Czech historians suggests that the fuselage code was 9N\*B (or R) and the squadron leader's pennant was painted below the windscreen. Smik used to paint his score on his aircraft and the presence of the Czechoslovak roundel can't be excluded as well. The red-white spinner appeared on the aircraft of one of No. 127 squadron leaders in October, 1944.

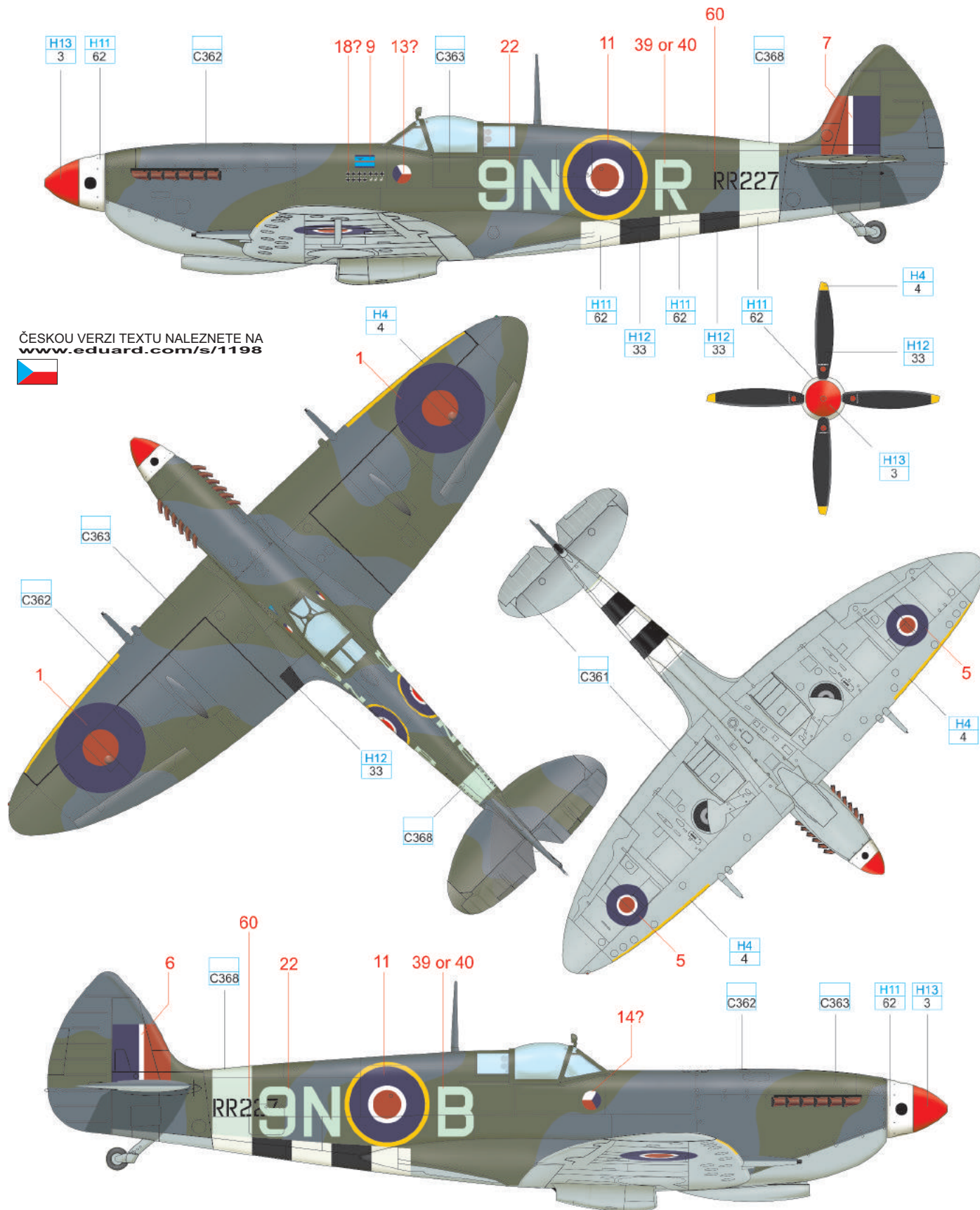

ČESKOU VERZI TEXTU NALEZNETE NA [www.eduard.com/s/1198](http://www.eduard.com/s/1198)



YELLOW	H4 4	RED	H13 3	WHITE	H11 62
SKY	C368	MEDIUM SEA GRAY	C361	OCEAN GRAY	C362
		DARK GREEN	C363	BLACK	H12 33

# G TB752, Flown by S/Ldr. Henry Zary, CO of No. 403 Squadron, Belgium, April, 1945

Henry Zary joined the RCAF in 1941 and served in Africa and Europe. He ended the war as Commanding Officer of No. 403 Squadron. Zary achieved five kills, the last of them on April 21, 1945 in the cockpit of this Spitfire.

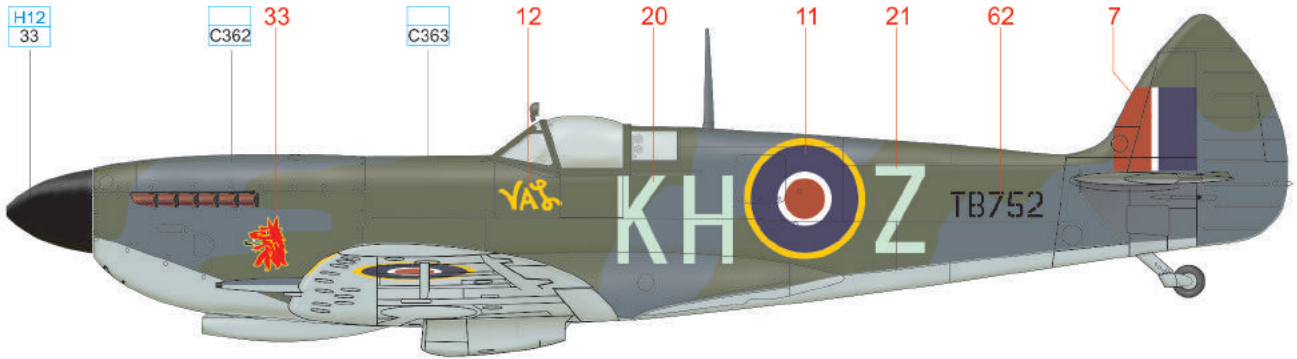

ČESKOU VERZI TEXTU NALEZNETE NA [www.eduard.com/s/1198](http://www.eduard.com/s/1198)

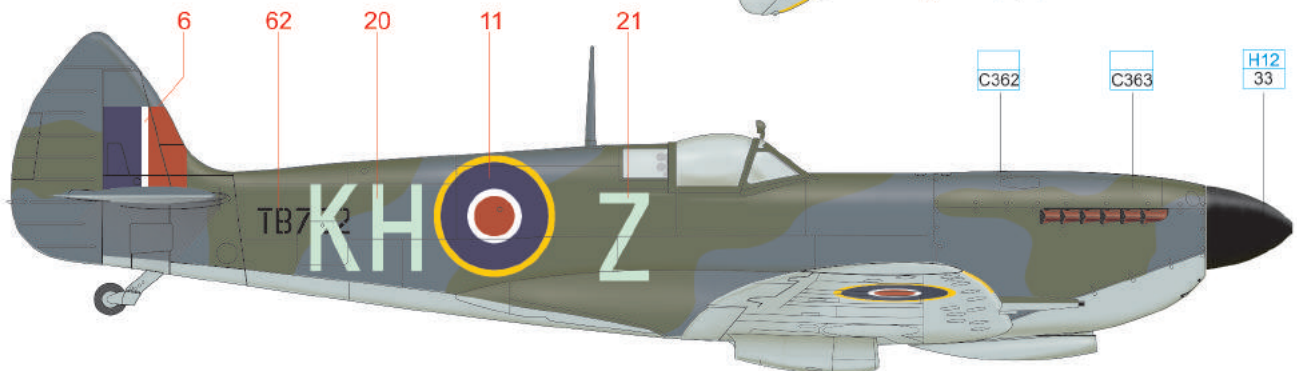
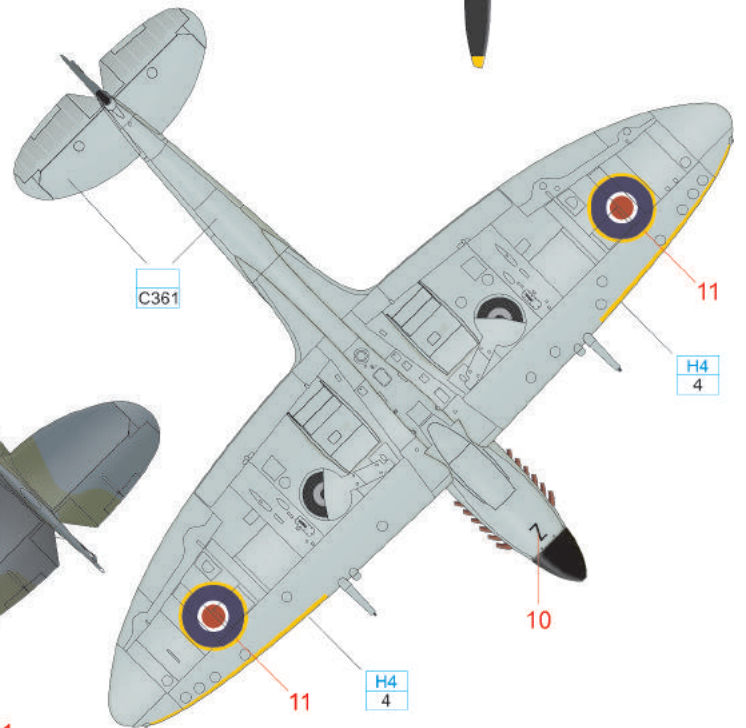
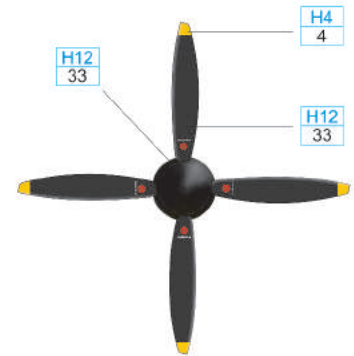
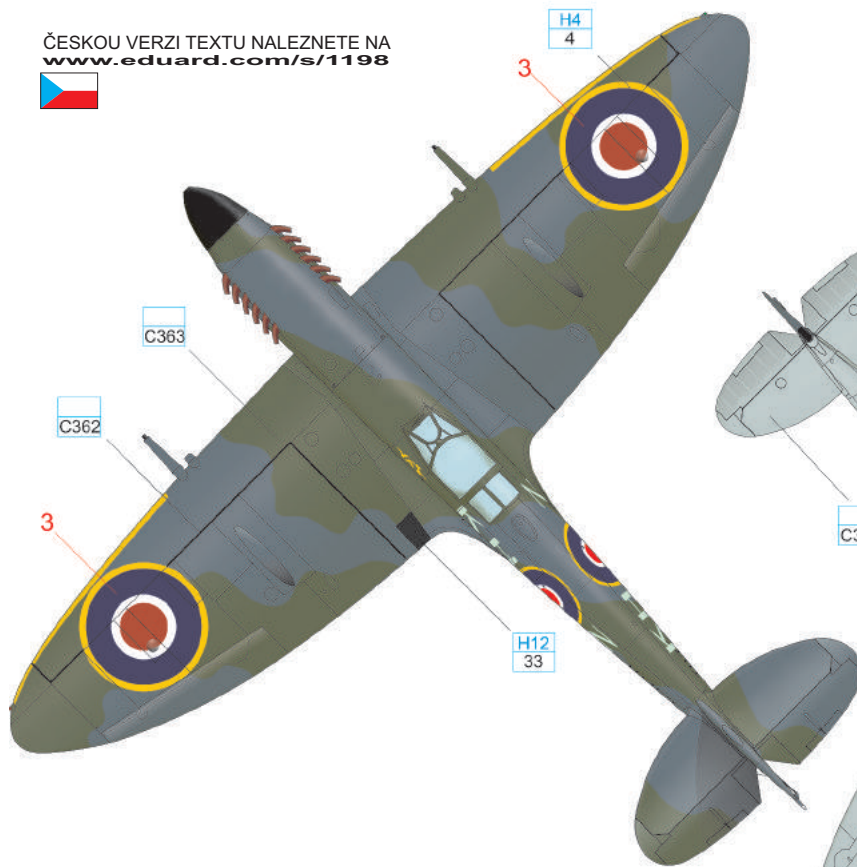

YELLOW H4 4

MEDIUM SEA GRAY C361 OCEAN GRAY C362 DARK GREEN C363 BLACK H12 33

# H TB300, Flown by G/C Stan Turner, No. 127 Wing, Evere Airfield, Belgium, April, 1945

Percival Stanley Turner began his career in the Royal Air Force in 1939 and participated in aerial battles over France, Dunkerque, the Battle of Britain, and in the skies over Malta. He is credited with fourteen kills. Turner, as Wing Commander, was entitled to use his initials as an aircraft code. The Indian head on the cowling is a No. 421 Sqdn badge, the squadron being part of No. 127 Wing.

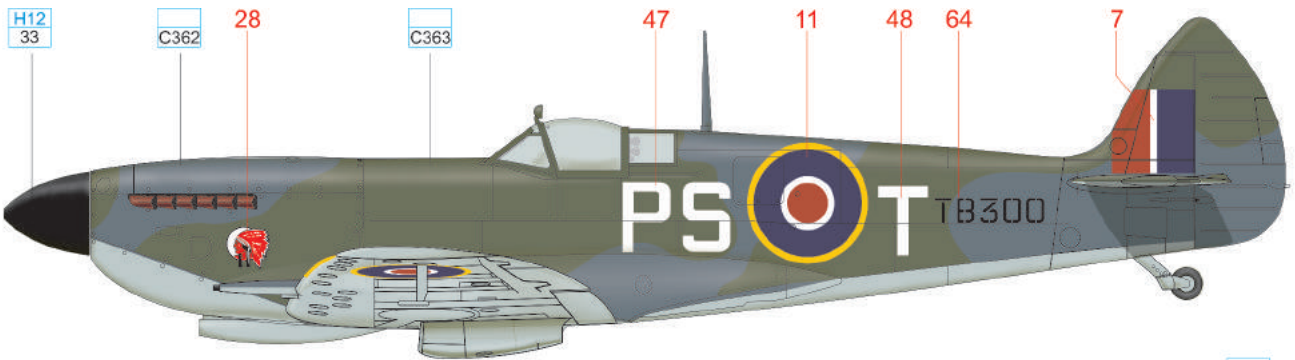

ČESKOU VERZI TEXTU NALEZNETE NA  
[www.eduard.com/s/1198](http://www.eduard.com/s/1198)

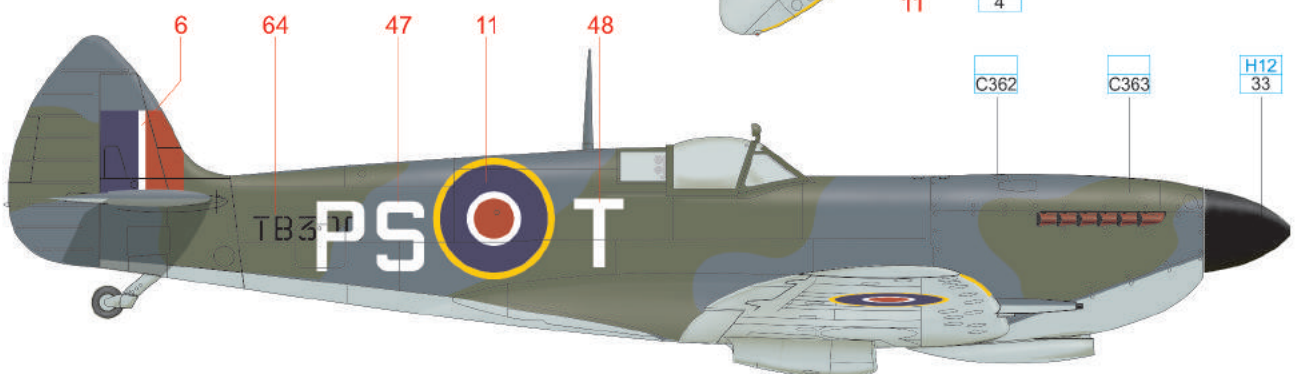
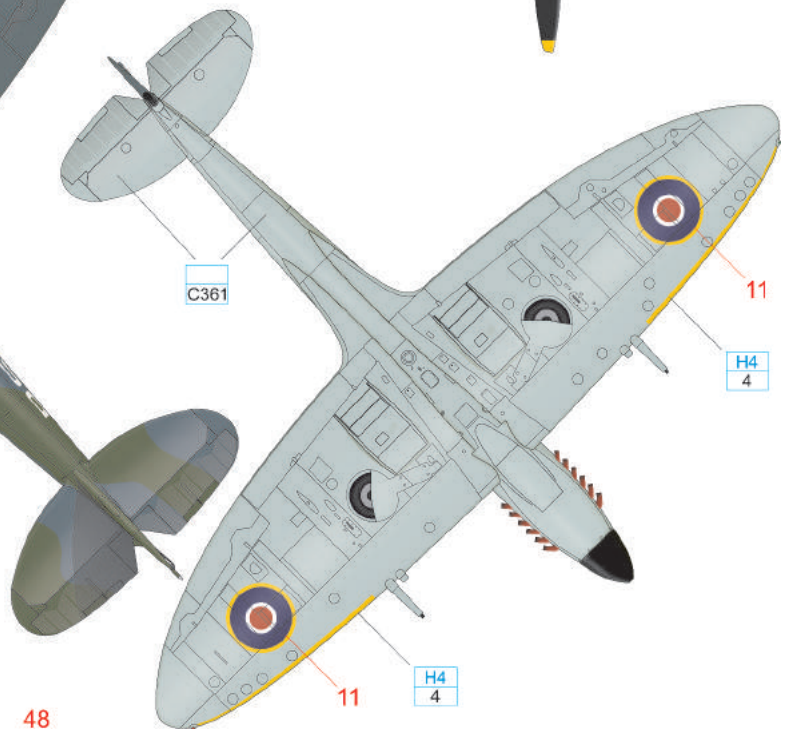
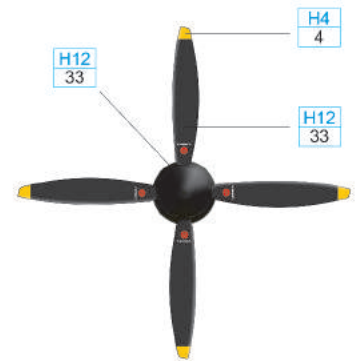
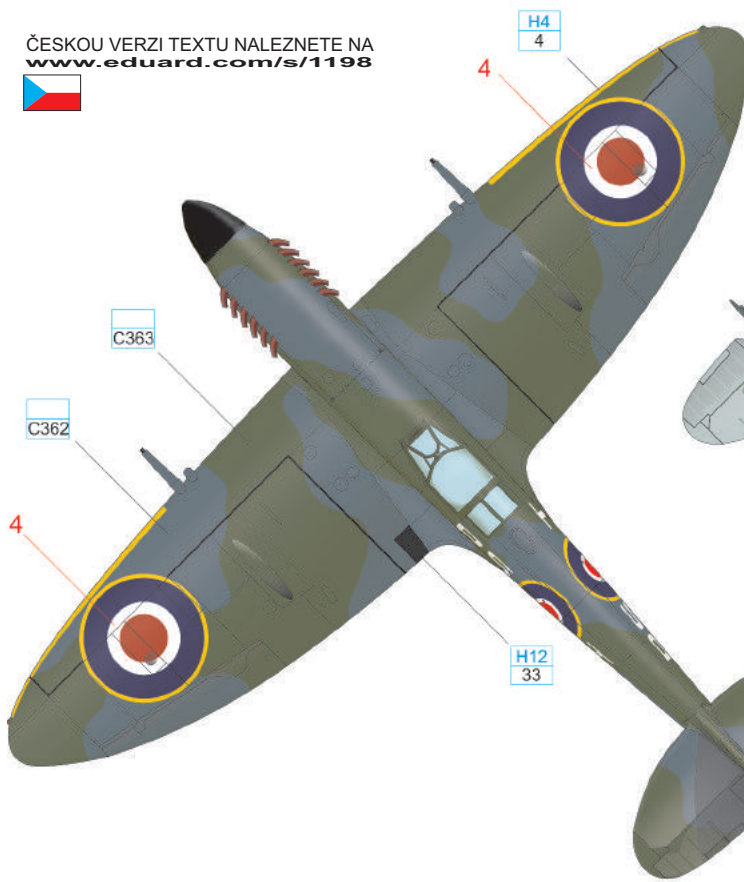

YELLOW	H4 4	MEDIUM SEA GRAY	C361	OCEAN GRAY	C362	DARK GREEN	C363	BLACK	H12 33
--------	---------	--------------------	------	------------	------	------------	------	-------	-----------

# Spitfire Mk.XVI

# STENCILING POSITIONS

