

## GERMAN WW II HEAVY FIGHTER 1:48 SCALE PLASTIC KIT



eduard

### Messerschmitt Bf 110 intro

The first pages of history for the famous Zerstörer Bf 110 were written at the end of 1934, when C-Amt RLM (the technical branch of the Reich's Air Ministry) issued a specification for a two seat, twin engine aircraft to fulfill a need within the Kamfzerstörer category. Submitted proposals came from Focke-Wulf (Fw 57), Henschel (Hs 124) and BFW (Messerschmitt Bf 110). In the spring of 1935, the RLM changed its thinking on the spec, and cancelled the universal Kamfzerstörer category in favor of two specific types, the Schnellbomber and the Zerstörer. The new concept of a heavy fighter of the RLM were best satisfied by the Messerschmitt design, which wasn't really dictated as much by the original specifications. The first prototype, the Bf 110 V1, first flew May 12, 1936, and the modified second prototype V2 was submitted to the Erprobungstelle in Rechlin on January 14, 1937. Four development aircraft, A-01 to A-04, powered by JUMO 210Da engines, were delivered at the beginning of 1938. A production run of 45 Bf 110Bs began in July, powered by JUMO 210Ga engines, delivering some 500kW (680hp). At the end of 1938, the production line for the high performance DB 601 finally got going, and these were mounted into the first major Bf 110 version, the Bf 110C. The Bf 110C, as was the case with the Bf 110B, was armed with two MG FF cannon, mounted in the fuselage below the cockpit floor, four MG 17 machine guns mounted in the nose and one rear firing MG 15 machine gun manned by the gunner/radio operator. There was a crew of two. The Luftwaffe received a total of 169 Bf 110Cs by September, 1939. The first combat experience of the type in Norway and France uncovered a small operational radius, unsuitable for an escort fighter. The first attempt to remedy the shortcoming came in the form of a large, underfuselage conformal type external fuel tank, called the Dackelbauch. The Bf 110C-3, adapted to carry this tank, were redesignated D-0. Results were not entirely satisfactory with the D version, and so there was a reconstruction of the fuel system, after which aircraft of the D version carried two drop tanks under the wings, and a small oil tank under the fuselage. The Bf 110D also standardized a longer fuselage, by way of an extension at the rear carrying a life raft and other emergency survival gear. This was a feature also evident on some subsequent Bf 110Es, which were equipped with bomb racks under the fuselage and wings. The majority of Bf 110Es were powered by the DB 601N engines. The following Bf 110F received the DB 601F engines housed in reshaped nacelles, with newer, more rounded spinners, aerodynamic features taken from the Bf 109F. Upgrading efforts were noted in the armament as well, where the MG FF were replaced by MG 151s. Significant changes came with the Bf 110G, powered by new DB 605 engines. The rear firing MG 82Z double gun appeared on the G-2, and with the G-4 came the replacement of four forward firing machine guns with two 30mm MK 108 cannon. The G-4 also saw larger rudders mounted. The Bf 110 went through not only technical changes throughout its career, but also through a development of its operational use. It entered the war as a heavy escort and attack fighter. By the time of the Battle of Britain, it became apparent that the aircraft, in the role of escort fighter, had been pushing the envelope of its capabilities. On the contrary, as a defensive weapon against British bombers, the Bf 110 made an extremely good showing of itself, and remained a deadly foe through to the end of the war. The placement of RAF bombing operations within nighttime hours from 1941 brought the Bf 110 into the realm of nightfighting on the Western Front. On the Eastern Front, they excelled as fast fighter bombers. Their earlier role as a day attack fighter was still fulfilled not only on the Eastern Front (where they were employed throughout the war successfully even as the originally envisioned escort fighter), but also on the Western Front into the depths of the summer of 1944, where the role was abandoned primarily, and finally. As a nightfighter in the G-4 version, thanks to a heavy forward firing armament and radar, they soldiered on literally until the very end of the war. As such, it was the nightfighter role that would prove to be the most significant for the Bf 110 during the course of the Second World War.

### The Bf 110G-2 Version

The evolution of the Bf 110 line was to continue in 1941 with the introduction of the Me 210, a result of the evolution of the original design coupled with combat experience. Major ongoing problems with the prototypes and unspectacular results in combat halted production of Me 210 at under 300. The role of the heavy fighter and fighter-bomber for the Luftwaffe would need to continue to be served by the Bf 110, calling for a list of changes and modifications.

The installation of the newly developed DB 605 engines (1470hp at higher performance) allowed for the development of the stronger and aerodynamically refined 'G' version, represented in combat by the G-2 and G-4. A wide variation in armament carried led to a wide assortment of missions flown by the G-2 over the Reich, northern Europe, the eastern Front and over the Mediterranean. The Bf 110G-2 was used as a long range heavy fighter, fighter-bomber, ground support and reconnaissance aircraft. The Bf 110G-2 didn't find its forte until the escalation of the Allied day bombing offensive in 1943. The Luftwaffe lacked a weapon that would be capable of effectively breaking up tight formations of Allied four-engined bombers. The task was to be carried out by heavily armed versions of twins already in service such as the Ju 88, Ju 188, Do 217 and especially the Bf 110G-2. Here appeared a wide assortment of both factory and field modifications, which saw upper nose MG 17 guns replaced with 20 mm MK 108 cannon (as the R2), or the lower MG 151/20 guns replaced with 37 mm BK 37 (as the R1) in a large lower housing. Often, there was an M1 field modification, which saw the removal of the lower bomb-rack and replacing it with a pair of 20 mm cannon. There were also combinations of these, or the replacement of the upper MG 17s with two MG 151 cannon, not officially belonging to any field 'Rustsatz' modifications of the Bf 110G-2. Despite the wide variety of cannon armament used in the aircraft, the weapon mostly attributed to the Bf 110G-2 were the underwing firing tubes for four Wfr.Gr. 21 projectiles. The Bf 110G-2 was established as a fighter within the Defense of the Reich system with varying degrees of success until the spring of 1944, when increasingly effective escort fighters often decimated them well before they were able to reach the attacking bomber formations. Their demise was compensated for by modified single engine Fw 190A-7 and A-8 R2 (Eduard Cat.No.8175), and the Bf 110G exclusively became a very successful night fighter (Eduard Cat.No.8206).

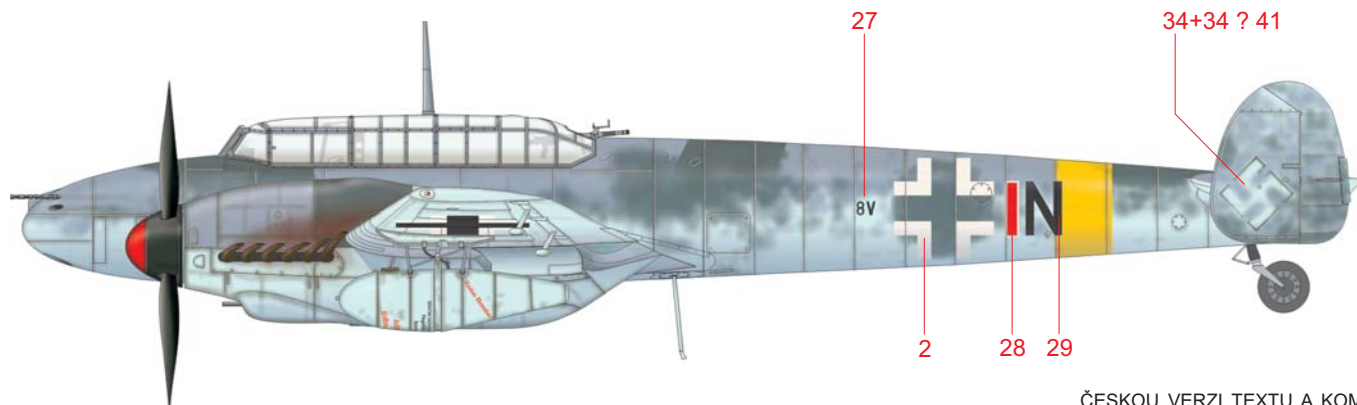

FOR COMPLETE PROFILE PLEASE REFER  
[www.eduard.com/info/photos/8205](http://www.eduard.com/info/photos/8205)

ČESKOU VERZI TEXTU A KOMPLETNÍ  
KAMUFLÁŽNÍ SCHEMA NALEZNETE NA  
[www.eduard.com/info/photos/8205](http://www.eduard.com/info/photos/8205)

### E 5./NJG 200, Russia - 1943

Bf 110G-2s that found their way into the services of Nachtjagdgeschwader 200 on the eastern front were used in a way worth noting. The standard Bf 110G-2 modified to M1 standard (cannon tub under the fuselage) with no on-board radar or radio modifications, was used for night fighting using the guidance system of Freya and Würzburg (Helle Nachtjagd). The character of the war on the eastern front was hardly conducive to this type of warfare, but the actions of NJG 200 illustrates the need for the protection of German assets and supply lines against Soviet night attacks.

Along with the mounting of anti-aircraft defenses on rail cars, NJG 200, as 'Eisenbahn Geschwader' was able to operate in required locations along sections of the eastern front. The aircraft carries a somewhat dark camouflage scheme of RLM 74/75/76 with yellow identification markings. The white fuselage Balkenkruz is sprayed over irregular squiggles of 74, which is consistent with the time period of 1943-44. The red Staffel color appears on the spinner tips.

All of the presented schemes display an effort to darken the overall scheme with the additional spraying of irregular squiggles of RLM 74/75. These also serve to break up the well defined edge between the upper surface colors and the side RLM 76 surfaces. The inside surfaces of the vertical tails were treated in a similar fashion.

ATTENTION



UPOZORNĚNÍ



ACHTUNG



ATTENTION



注意



Carefully read instruction sheet before assembling. When you use glue or paint, do not use near open flame and use in well ventilated room. Keep out of reach of small children. Children must not be allowed to suck any part, or pull vinyl bag over the head.



Před započatím stavby si pečlivě prostudujte stavební návod. Při používání barev a lepidel pracujte v dobře větrané místnosti. Lepidla ani barvy nepoužívejte v blízkosti otevřeného ohně. Model není určen malým dětem, mohlo by dojít k požití drobných dílů.



lire soigneusement la fiche d'instructions avant d'assembler. Ne pas utiliser de colle ou de peinture à proximité d'une flamme nue, et aérer la pièce de temps en temps. Garder hors de portée des enfants en bas âge. Ne pas laisser les enfants mettre en bouche ou sucer les pièces, ou passer un sachet vinyl sur la tête.



Von dem Zusammensetzen die Bauanleitung gut durchlesen. Kleber und Farbe nicht nahe von offenem Feuer verwenden und das Fenster von Zeit zu Zeit Belüftung öffnen. Bausatz von kleinen Kindern fernhalten. Verhüten Sie, daß Kinder irgendwelche Bauteile in den Mund nehmen oder Plastiktüten über den Kopf ziehen.



組み立てる前に必ず説明書をお読み下さい。接着剤や塗料をご使用の際は、窓を開けて十分な換気をおこない、火のそばでは使用しないで下さい。小さな子供の手の届かない所に必ず保管してください。部品や破片を噛んだり、なめたり、飲んだりすると大変危険です。又、部品を取り出した後のビニール袋は、小さな子供が頭から被ったりすると窒息する恐れがありますので、破り捨てて下さい。

INSTRUKTION SIGNS \* INSTR. SYMBOLY \* INSTRUKTION SINNBILDEN \* SYMBOLES \* 記号の説明



OPTIONAL  
VOLBA  
FACULTATIF  
NACH BELIEBEN  
選択する



BEND  
OHNOU  
PLIER SIL VOUS PLAIT  
BITTE BIEGEN  
折る



OPEN HOLE  
VYVRTAT OTVOR  
FAIRE UN TROU  
OFFNEN  
穴を開ける



SYMETRICAL ASSEMBLY  
SYMETRICKÁ MONTÁŽ  
MONTAGE SYMÉTRIQUE  
SYMMETRISCHE AUFBAU  
左右均等に組み立てる



NOTCH  
ZÁŘEZ  
L INCISION  
DER EINSCHNITT  
切る



REMOVE  
ODRÍZNOUT  
RETIRER  
ENTFERNEN  
移す



APPLY EXPRESS MASK  
AND PAINT  
POUŽIT EXPRESS MASK  
NABARVIT

PARTS



DÍLY



TEILE



PIÈCES



部品

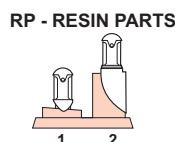
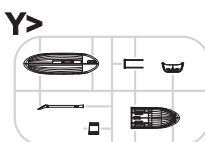
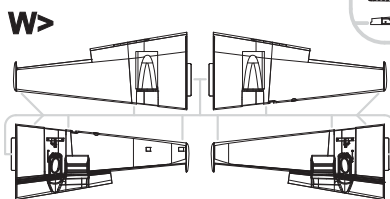
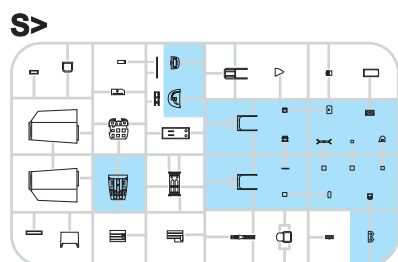
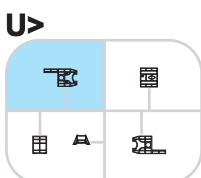
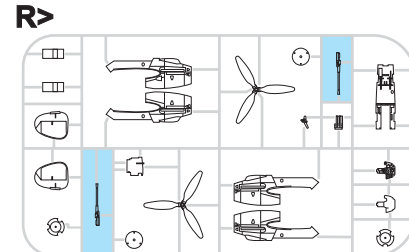
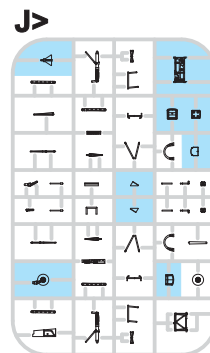
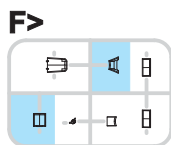
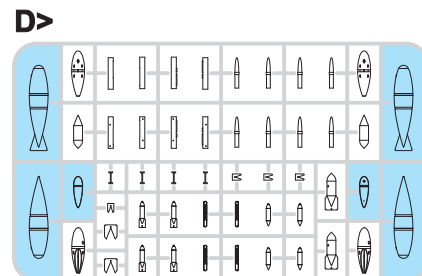
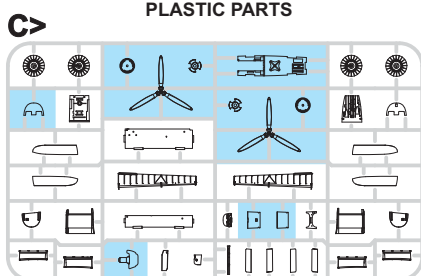
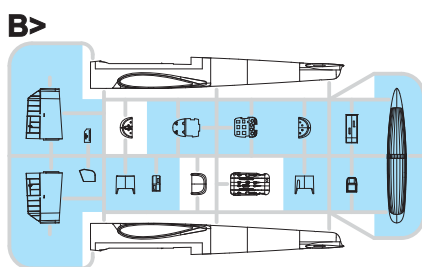

PE - PHOTO ETCHED  
DETAIL PARTS

eduard  
MASK

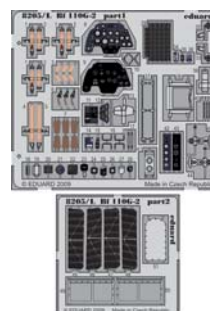

-Parts not for use. -Teile werden nicht verwendet. -Pièces à ne pas utiliser. -Tyto díly nepoužívejte při stavbě. -使用しない部品

COLOURS



BARVY



FARBEN



PEINTURE



色

GSI Creos (GUNZE)			
AQUEOUS	Mr.COLOR		
H 4	C4	YELLOW	
H 5	C5	BLUE	
H 7	C7	BROWN	
H 11	C61	WHITE	
H 13	C3	RED	
H 12	C33	FLAT BLACK	
H 37	C43	WOOD BROWN	
H 47	C41	RED BROWN	
H 65	C18	DARK GREEN	RLM70
H 68	C116	DARK GREY	

AQUEOUS	Mr.COLOR		
H 69	C37	GRAY	RLM65
H 70	C60	GRAY	RLM02
H 77	C137	TIRE BLACK	
H 80		KHAKI GREEN	
H 344		RUST	
H 417	C417	LIGHT BLUE	RLM76
Mr.METAL COLOR			
MC214		DARK IRON	
MC218		ALUMINIUM	
MC219		BRASS	

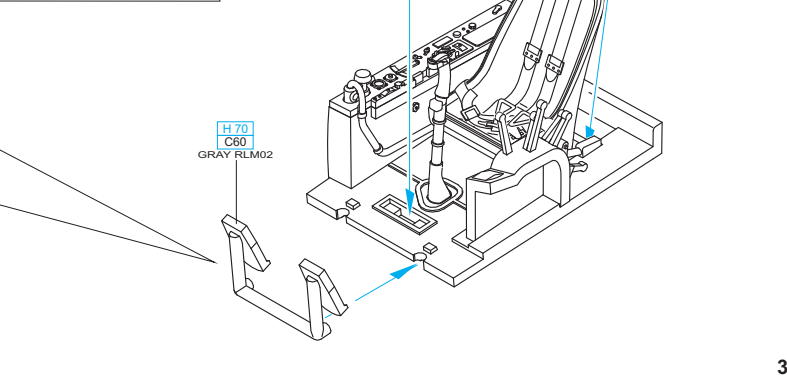
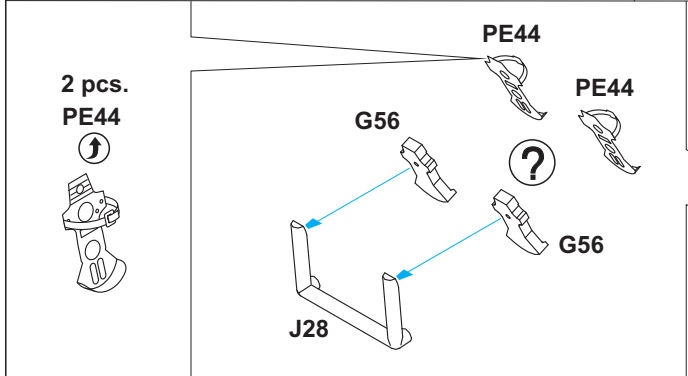
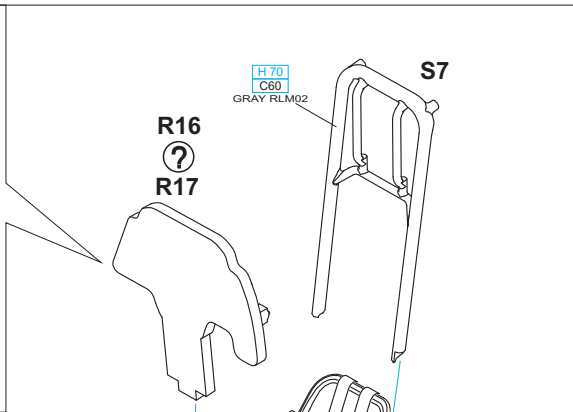
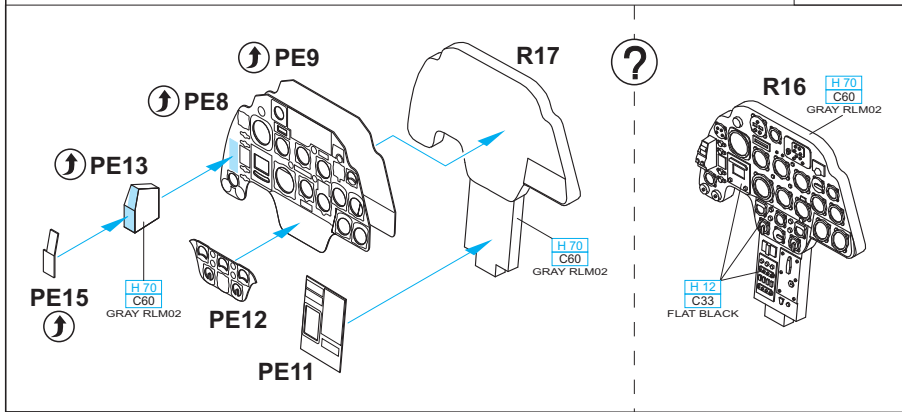
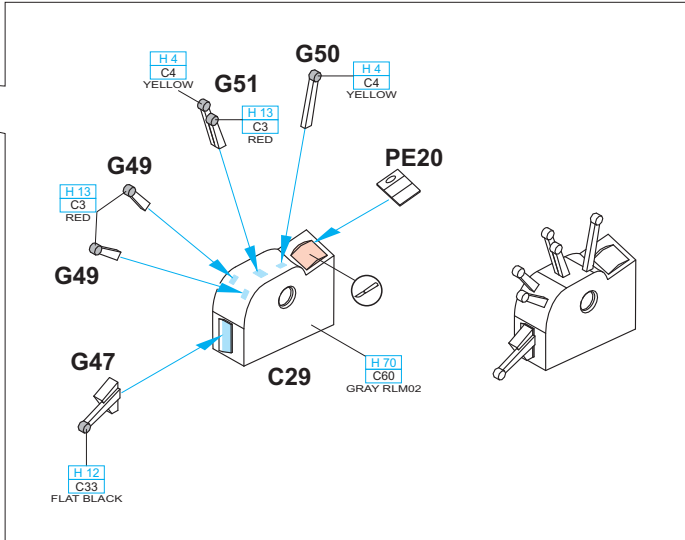
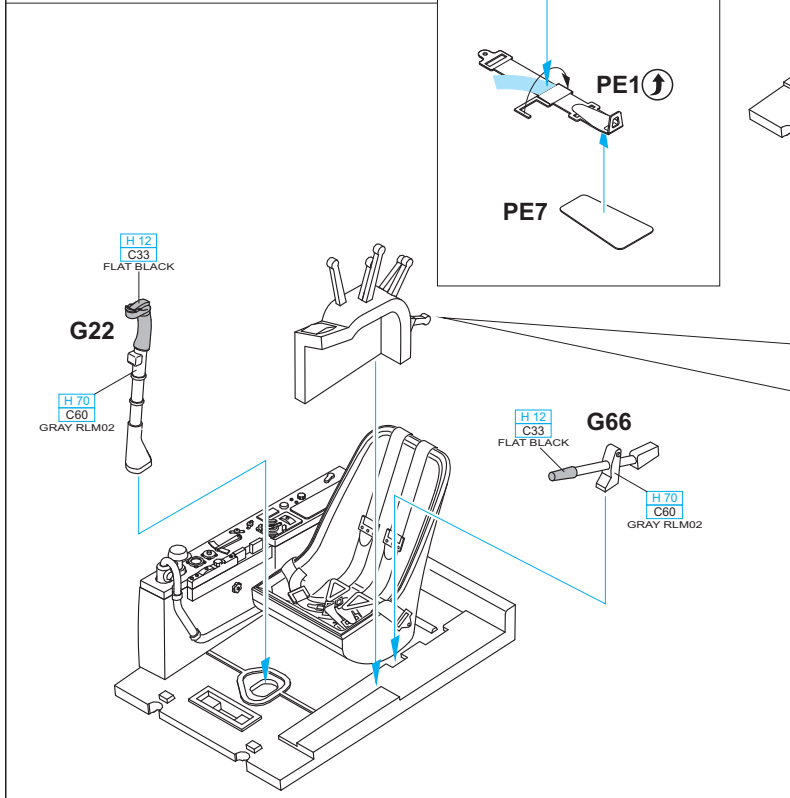
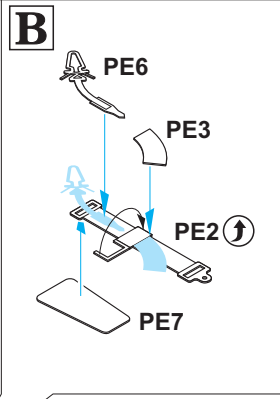
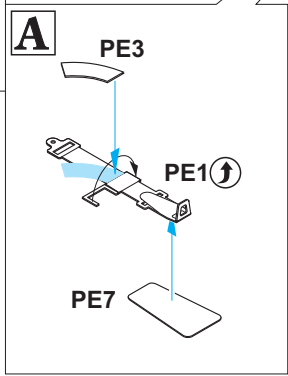
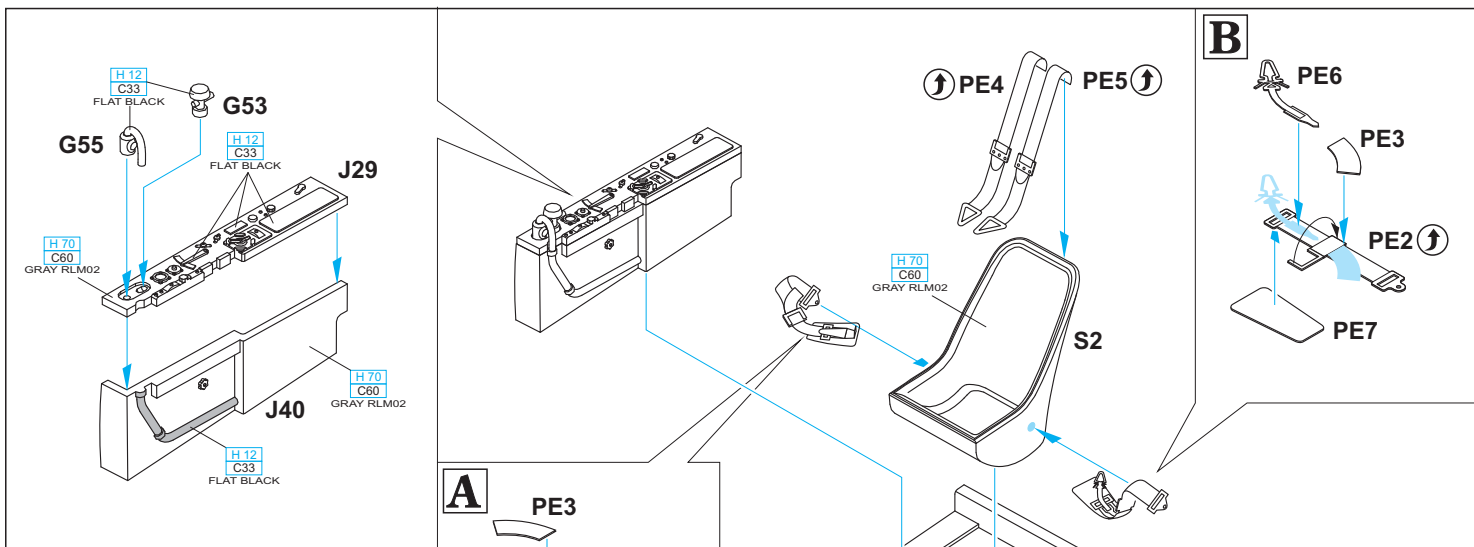

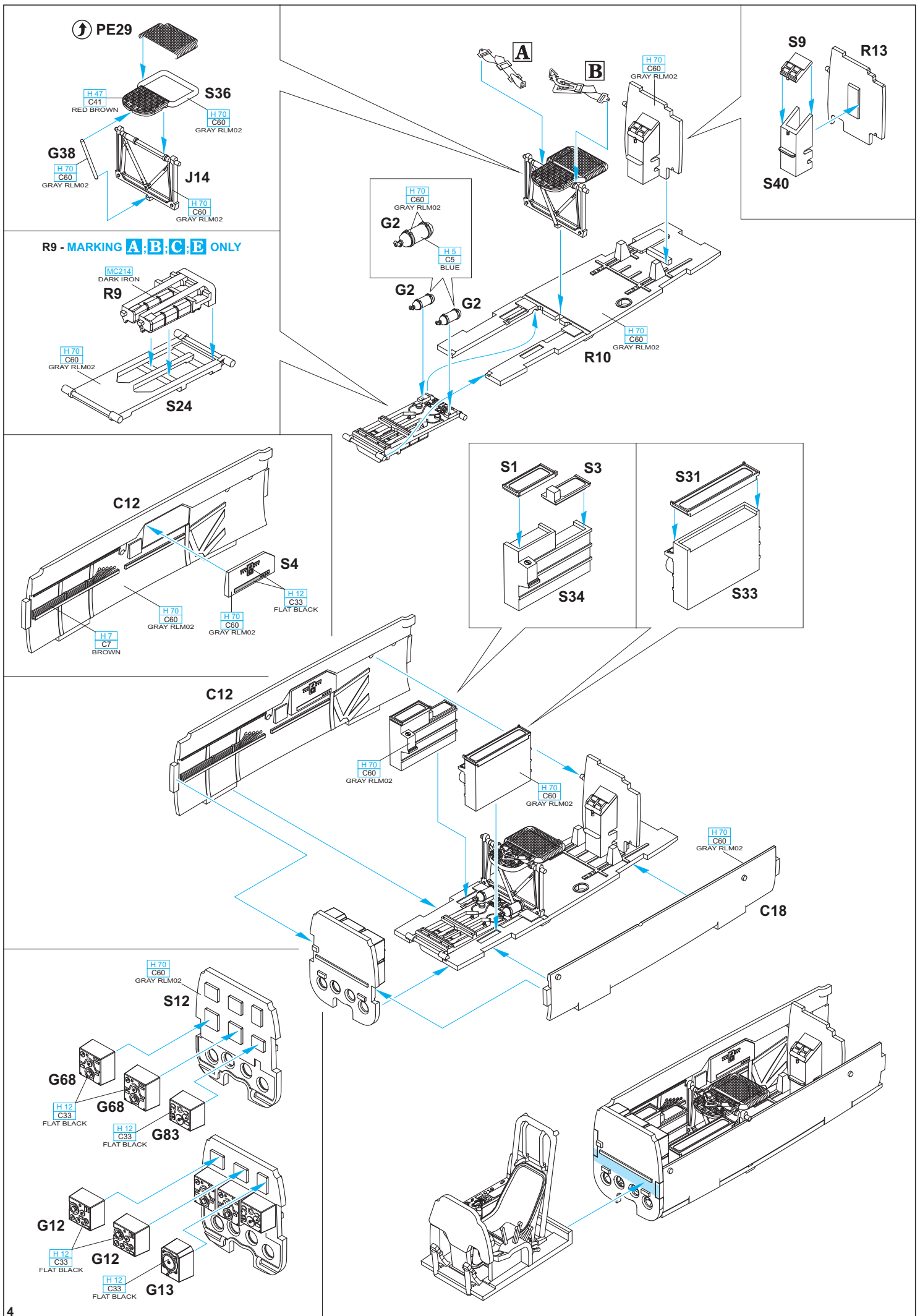

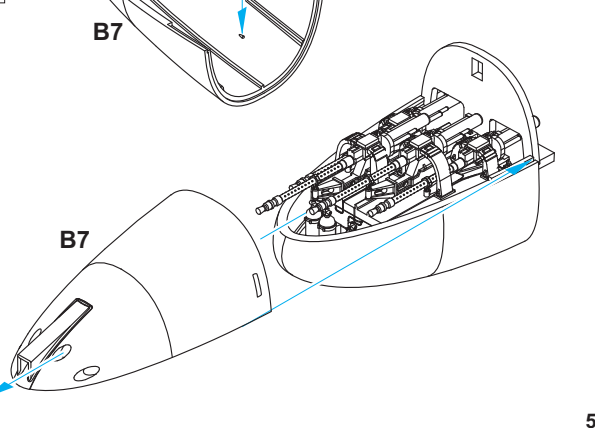
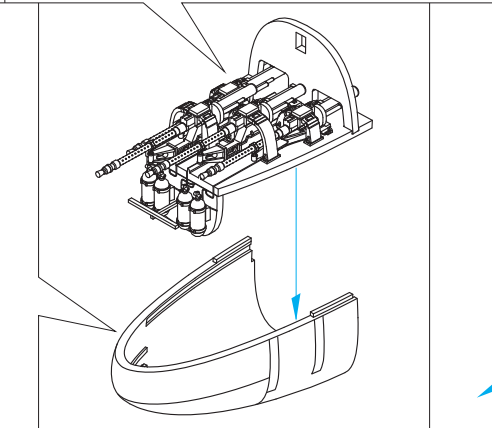
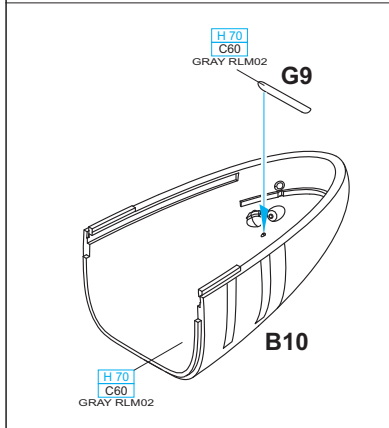
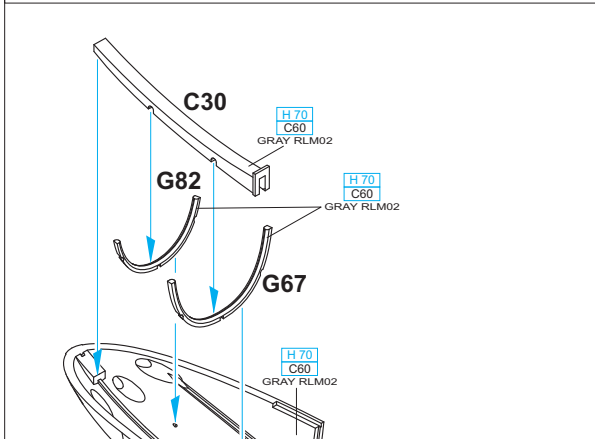
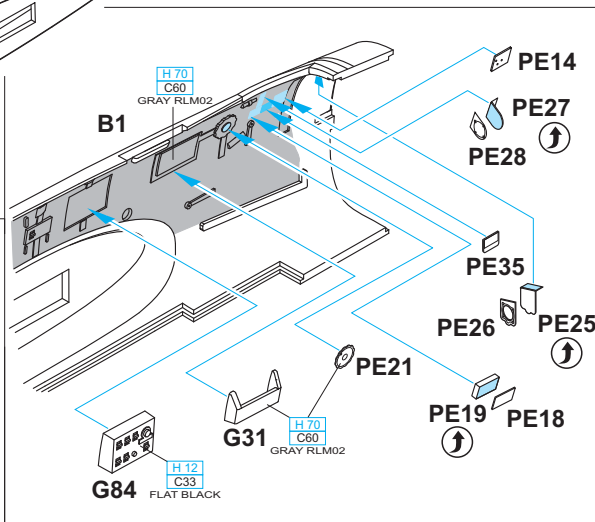
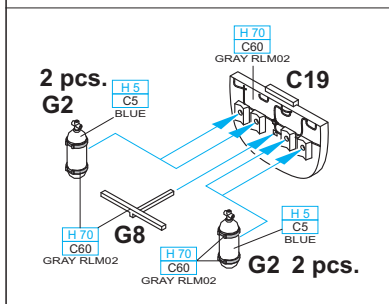
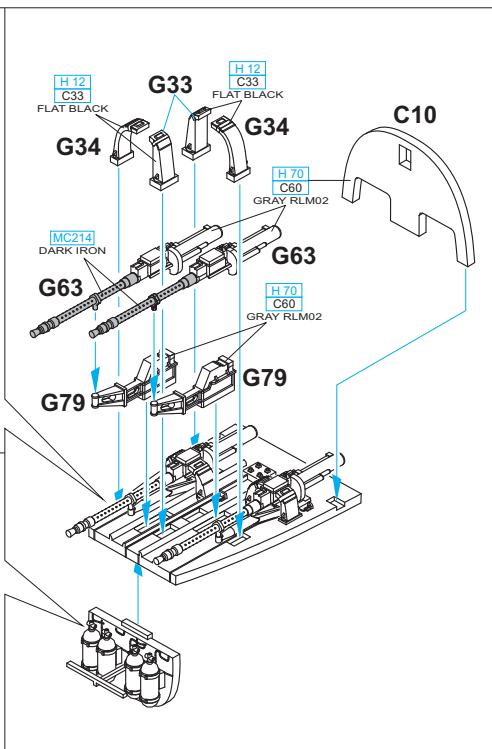
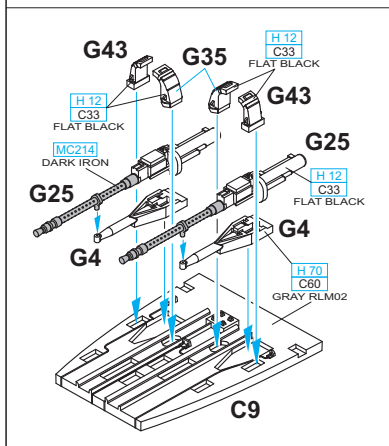
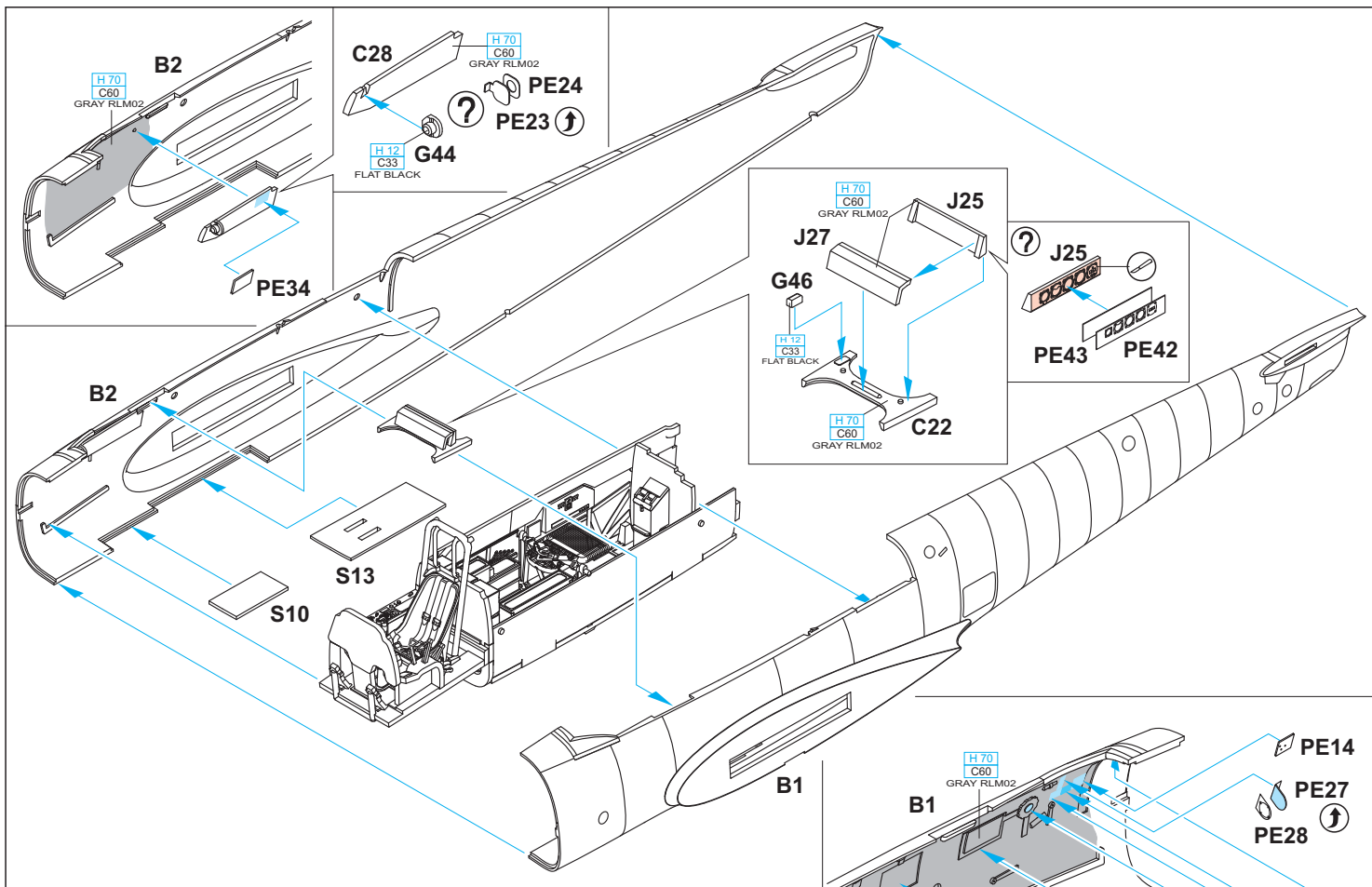

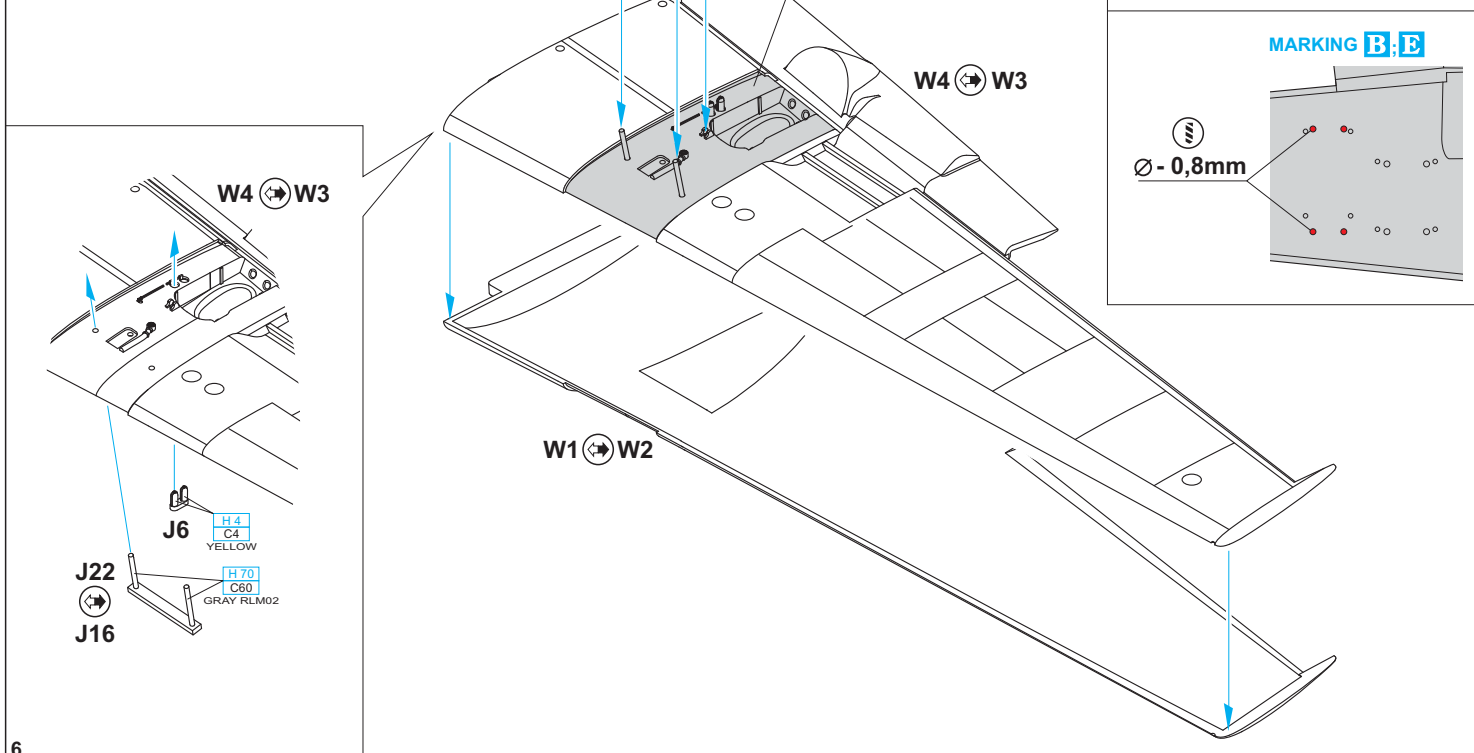
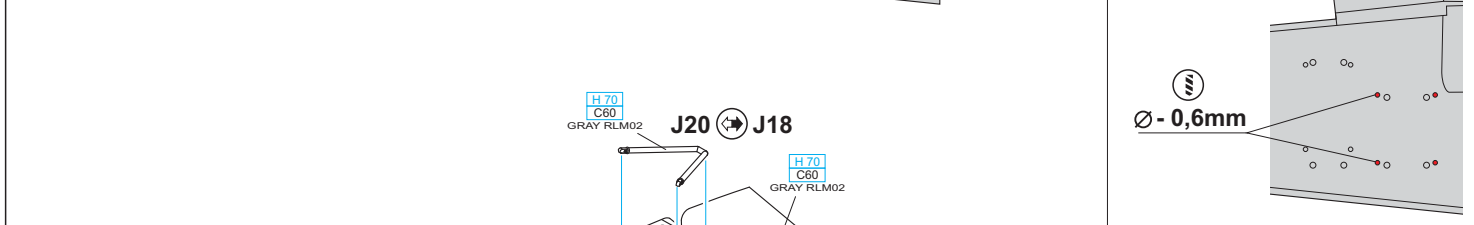
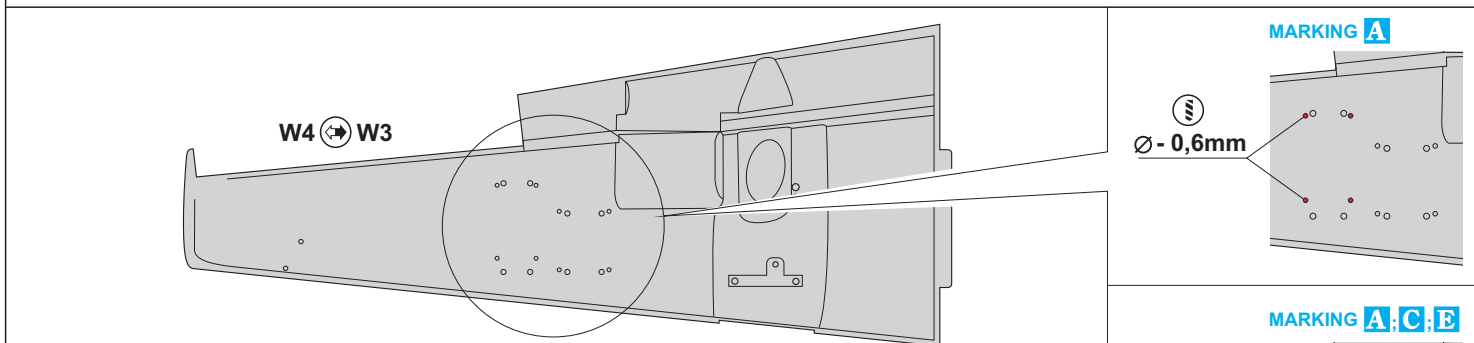
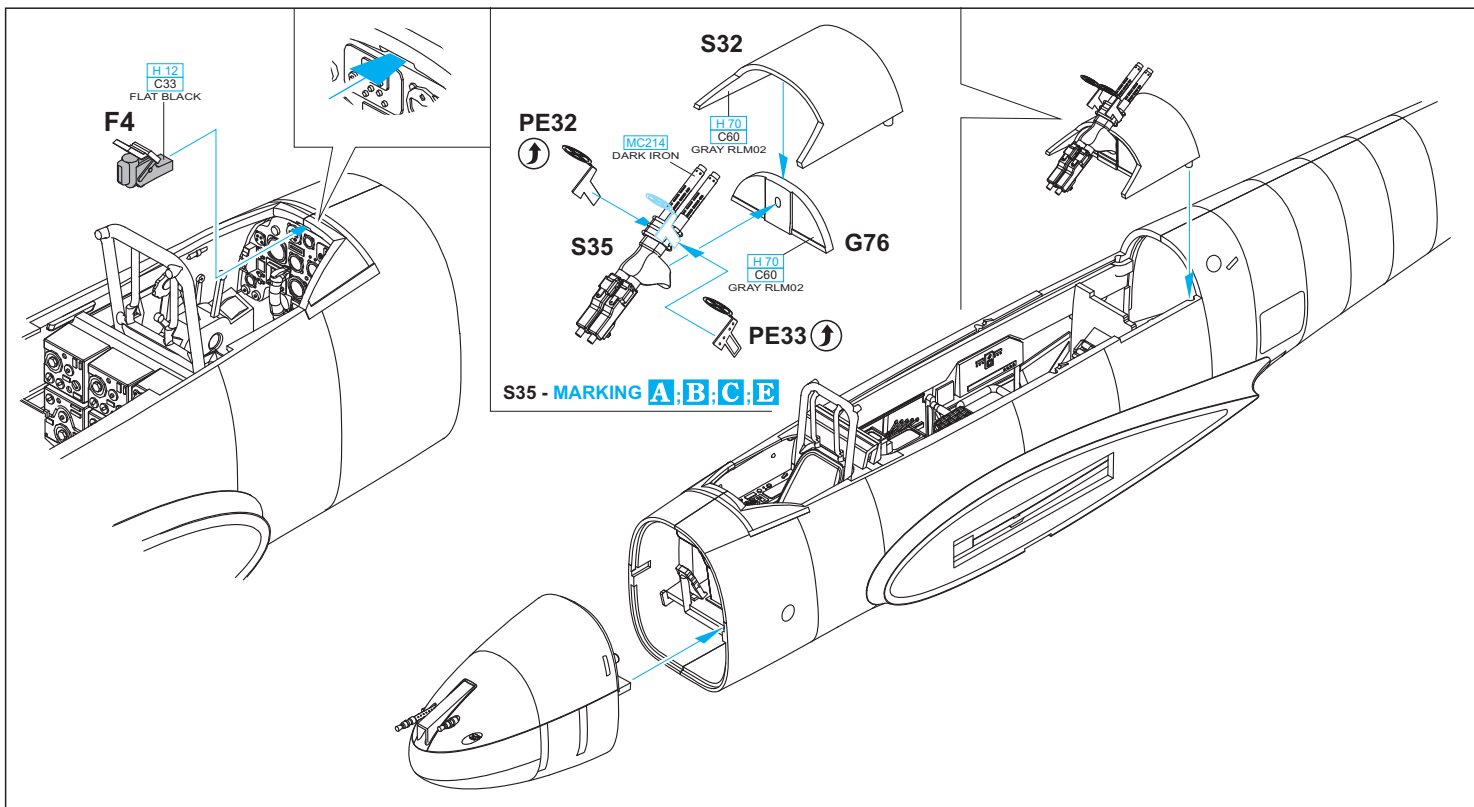

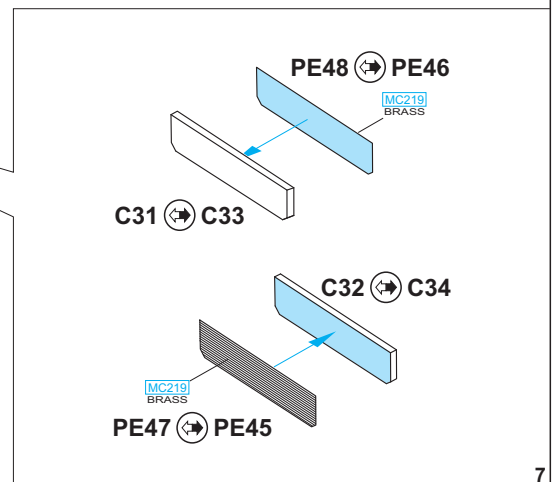
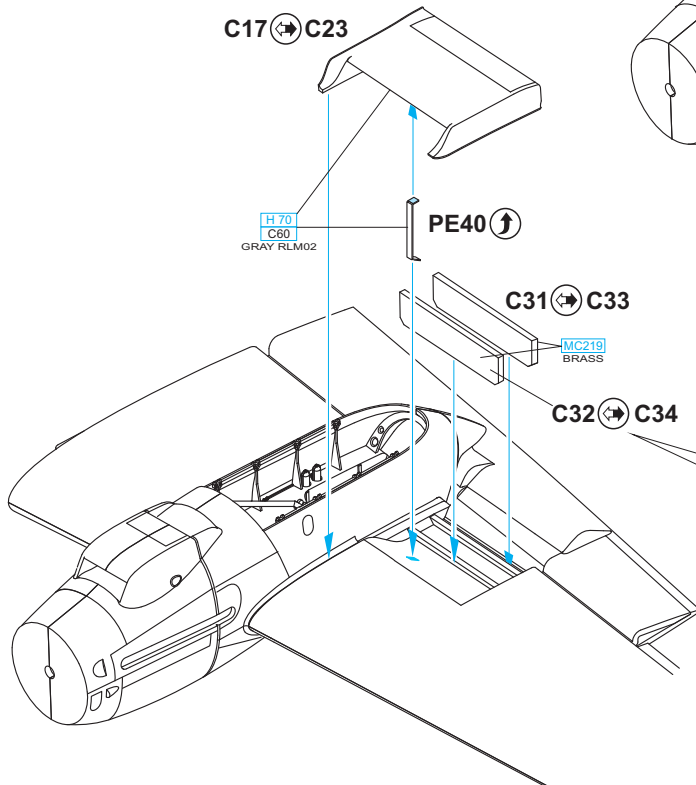
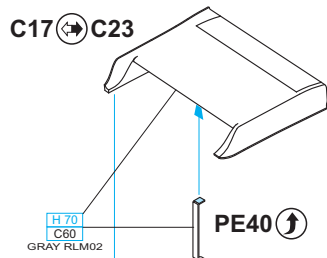
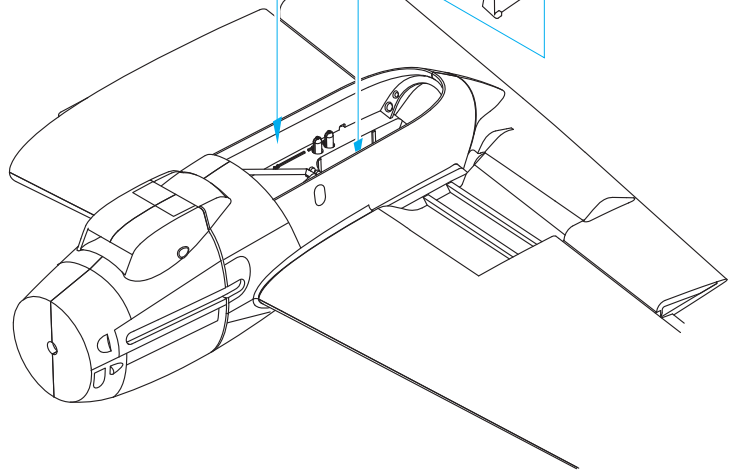
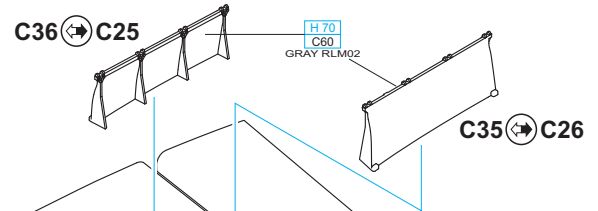
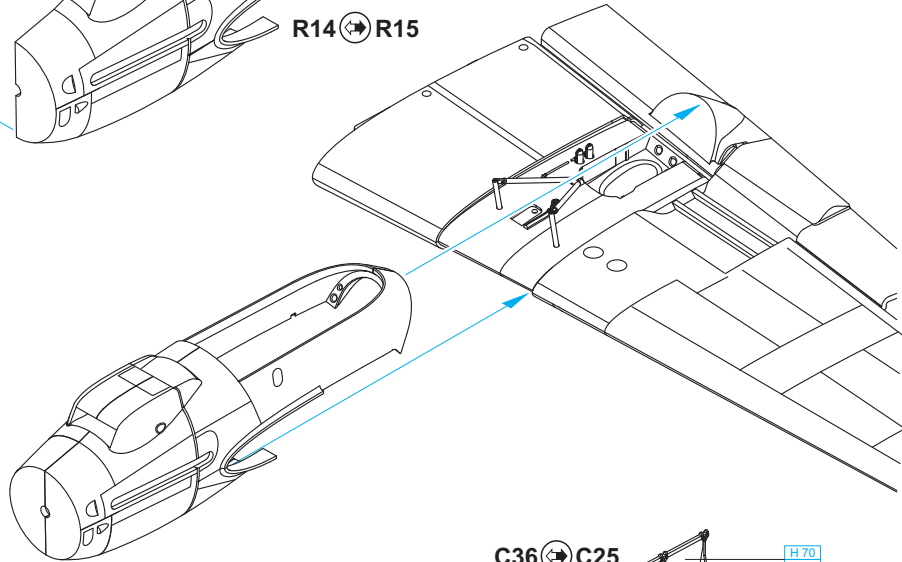
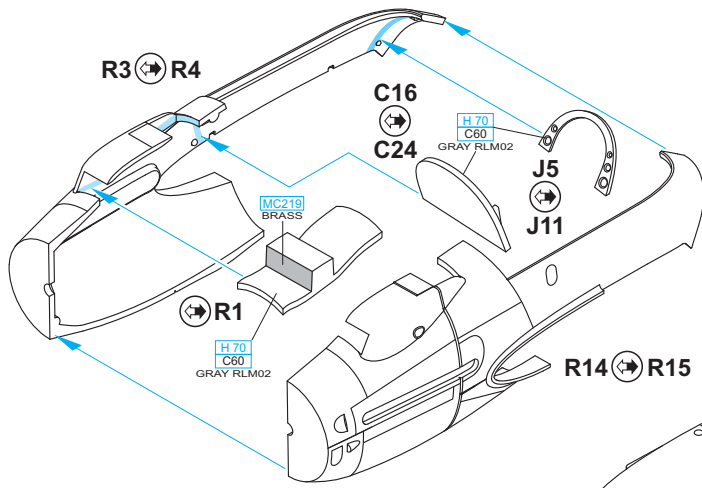

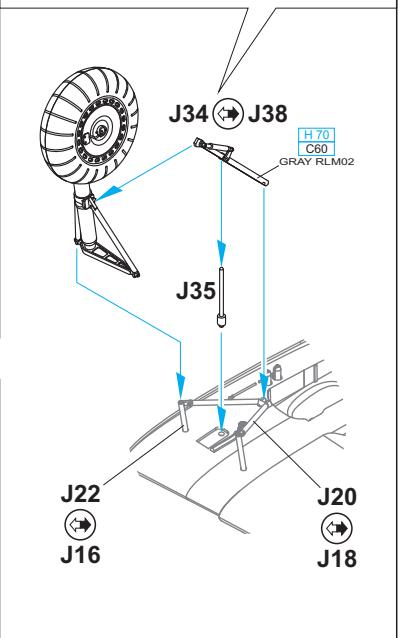
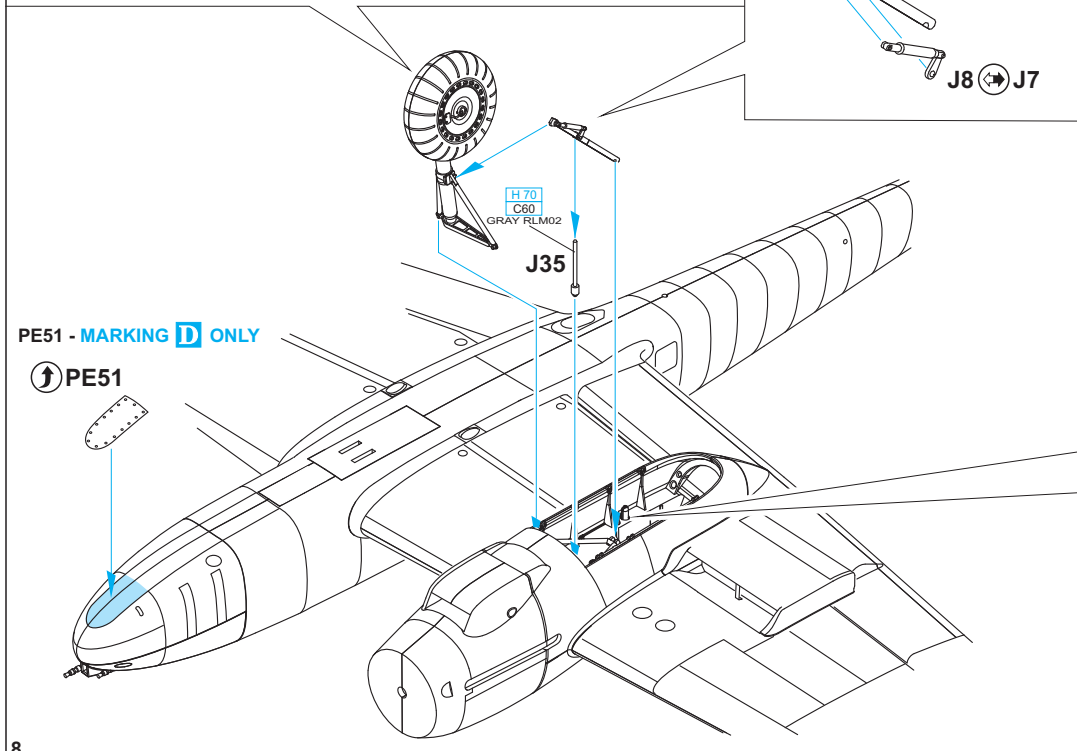
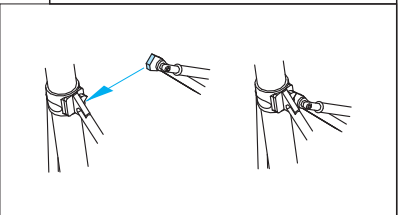
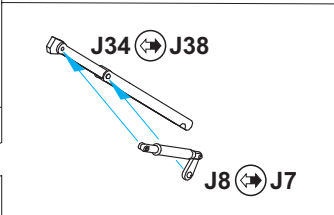
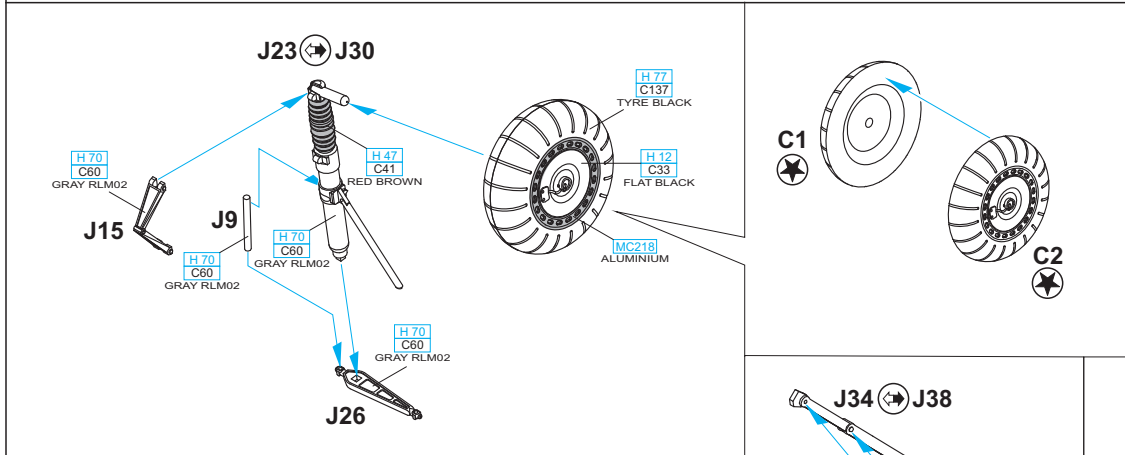
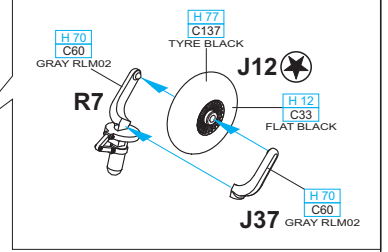
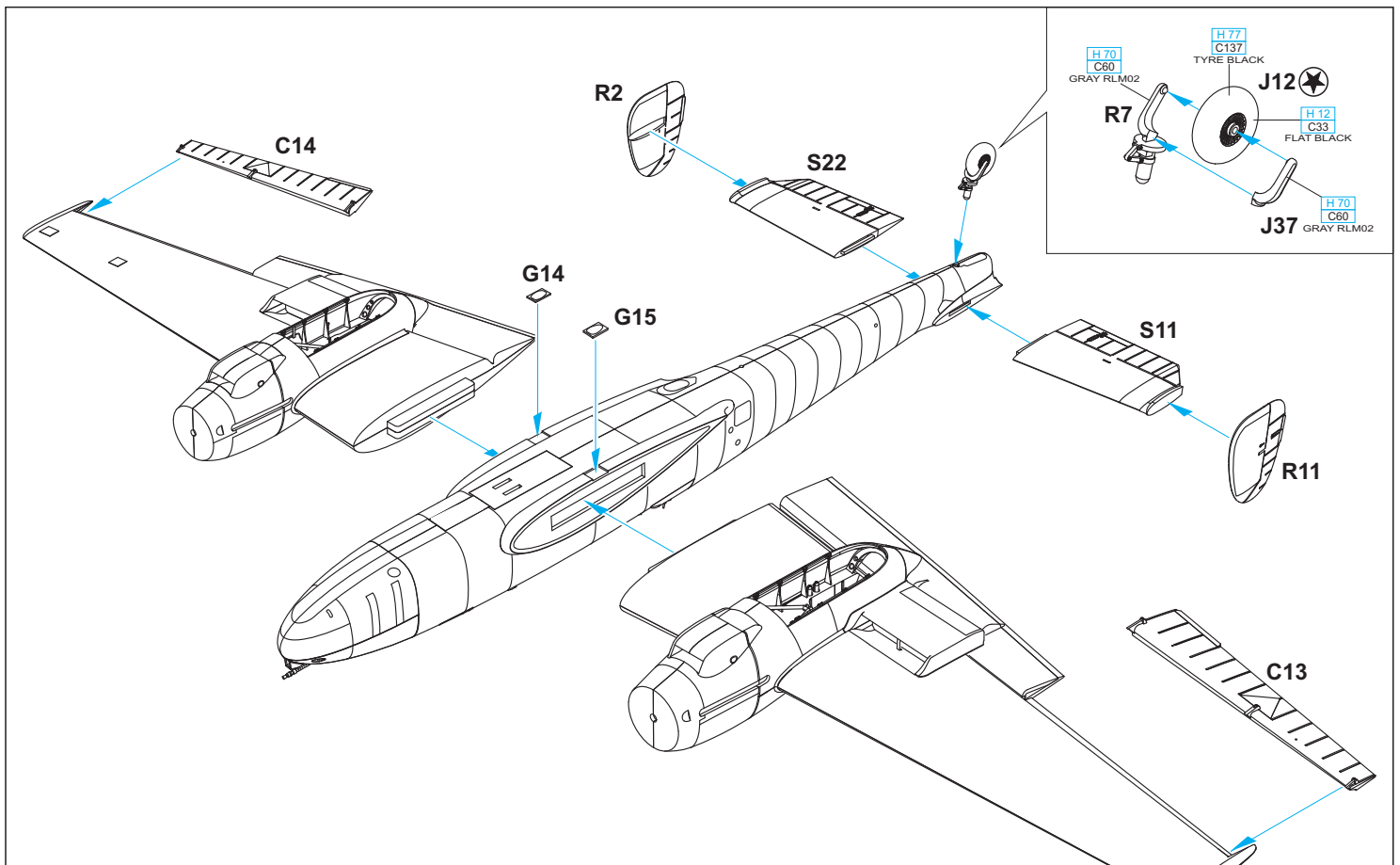



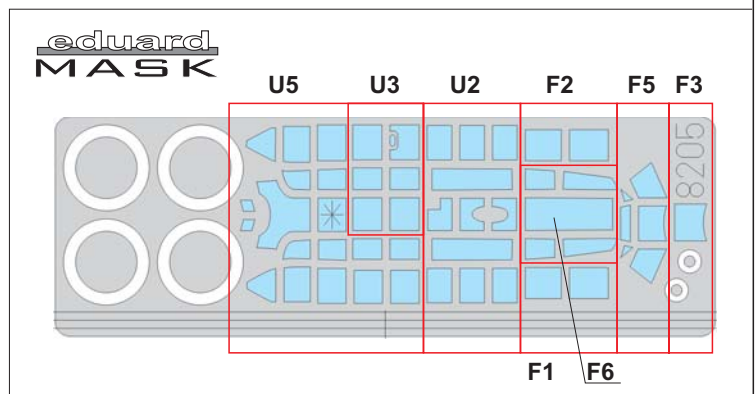
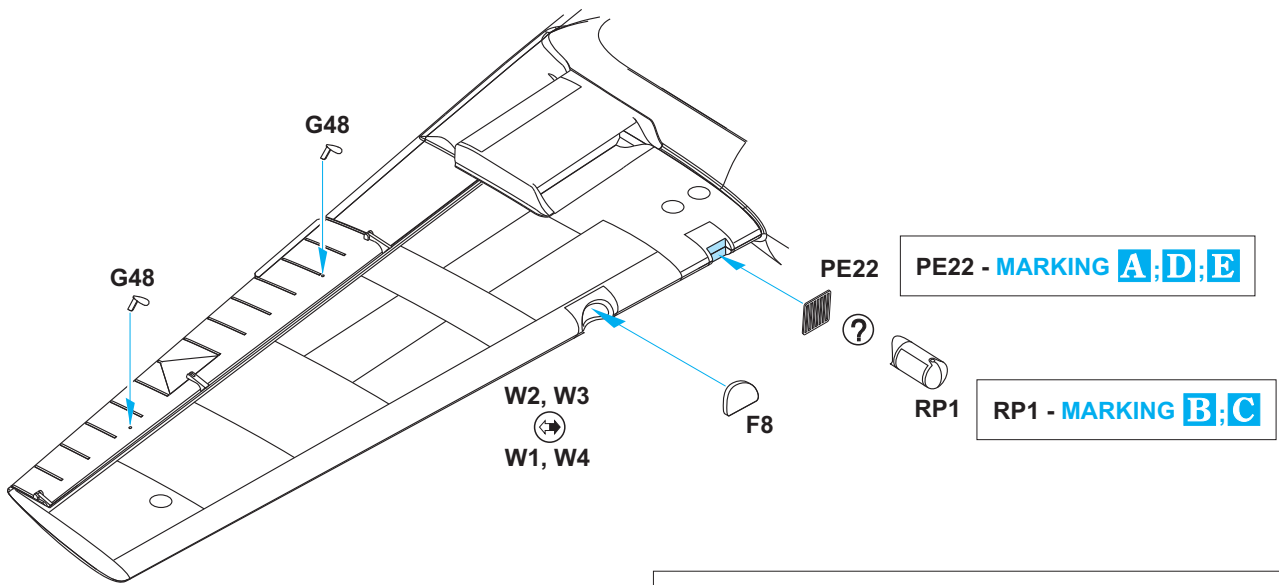
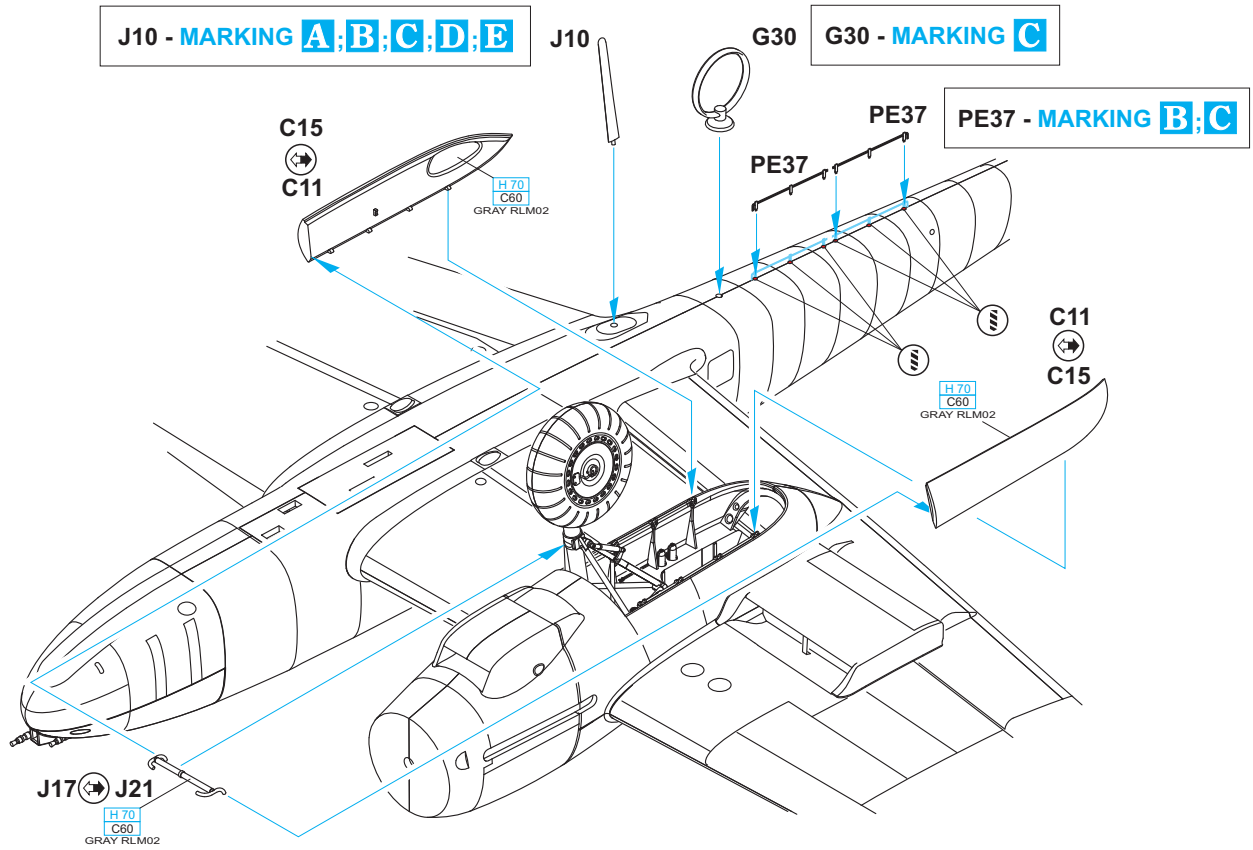

WE RECOMMEND TO GLUE J24/ J32 EXHAUST BESES TO ENGINE NACELLES FIRST, NEXT GLUE THE EXHAUST PIPES TO THE BASES.  
 DOPORUČUJEME NEJPRVE NALEPIT ZÁKLADNY VÝFUKŮ J24/ J32 DO MOTOROVÝCH GONDOL, TEPRVE POTÉ VLEPOVAT JEDNOTLIVÉ VÝFUKY.

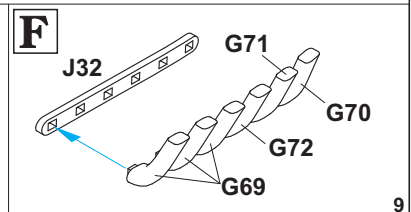
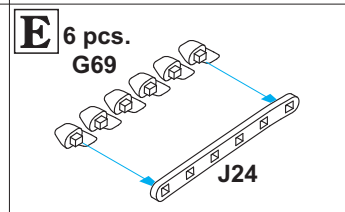
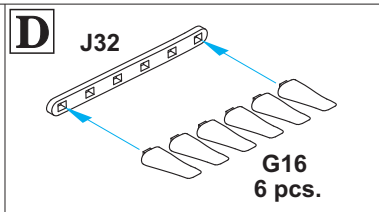
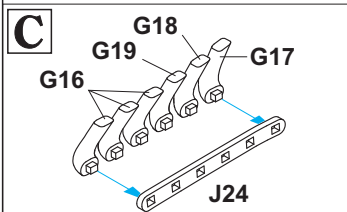

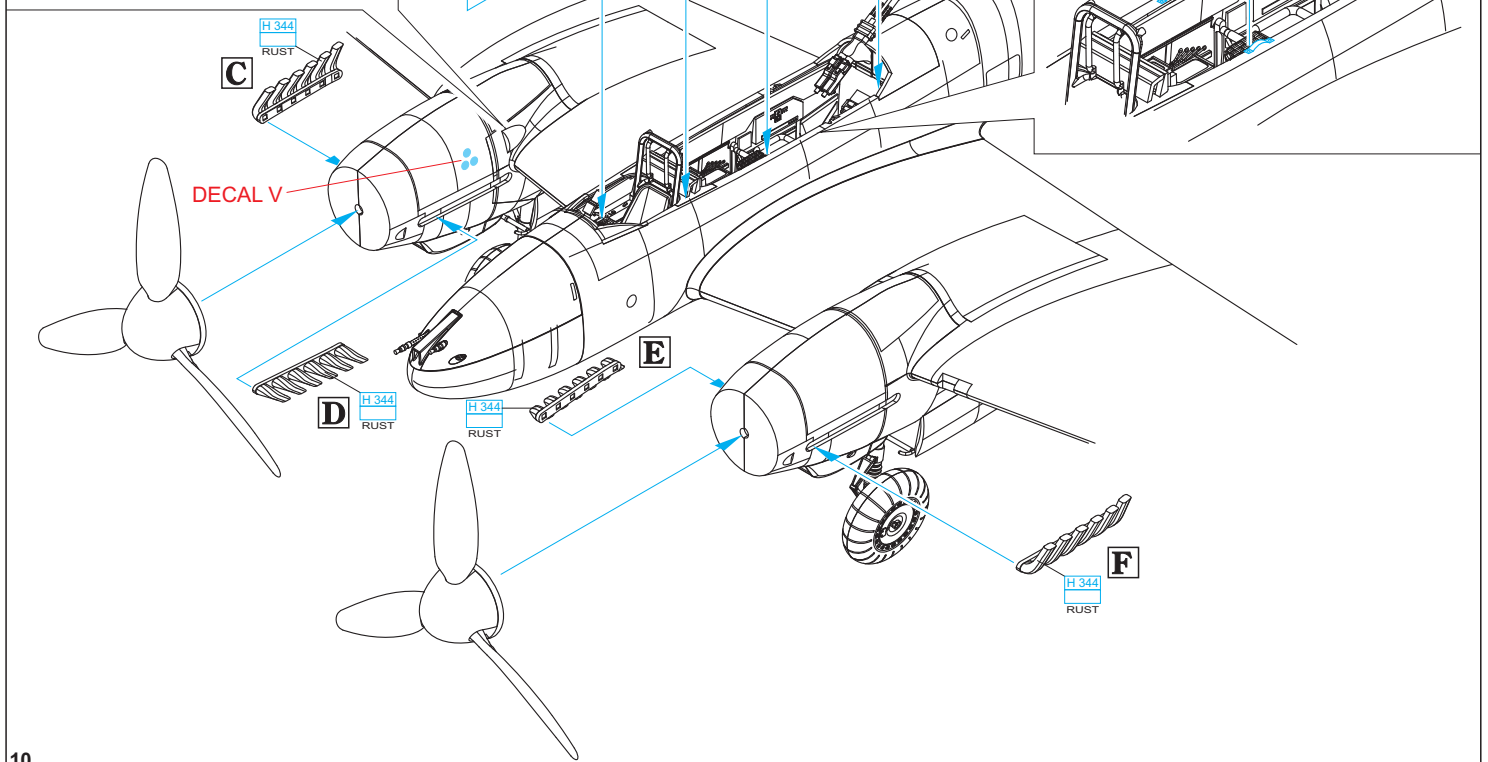
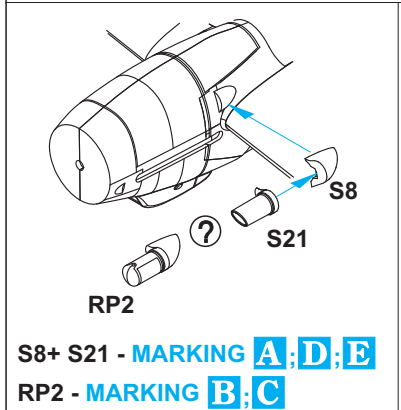
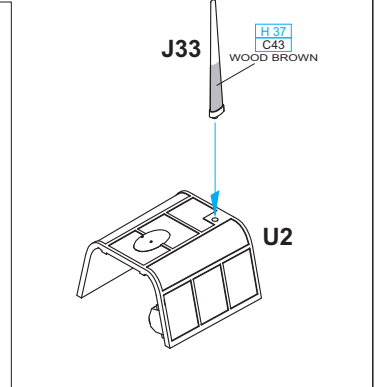
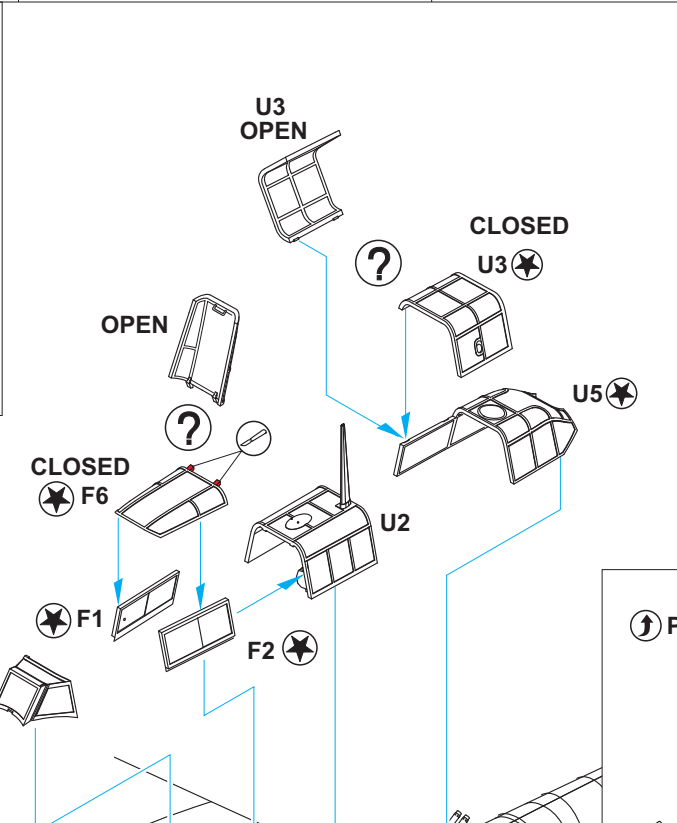
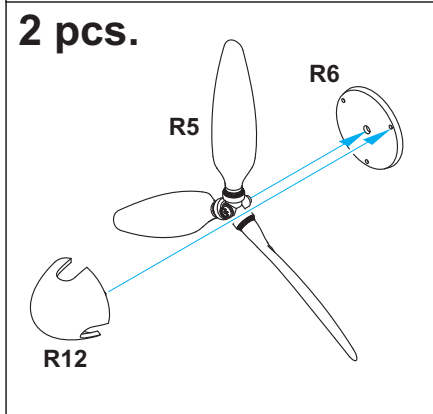
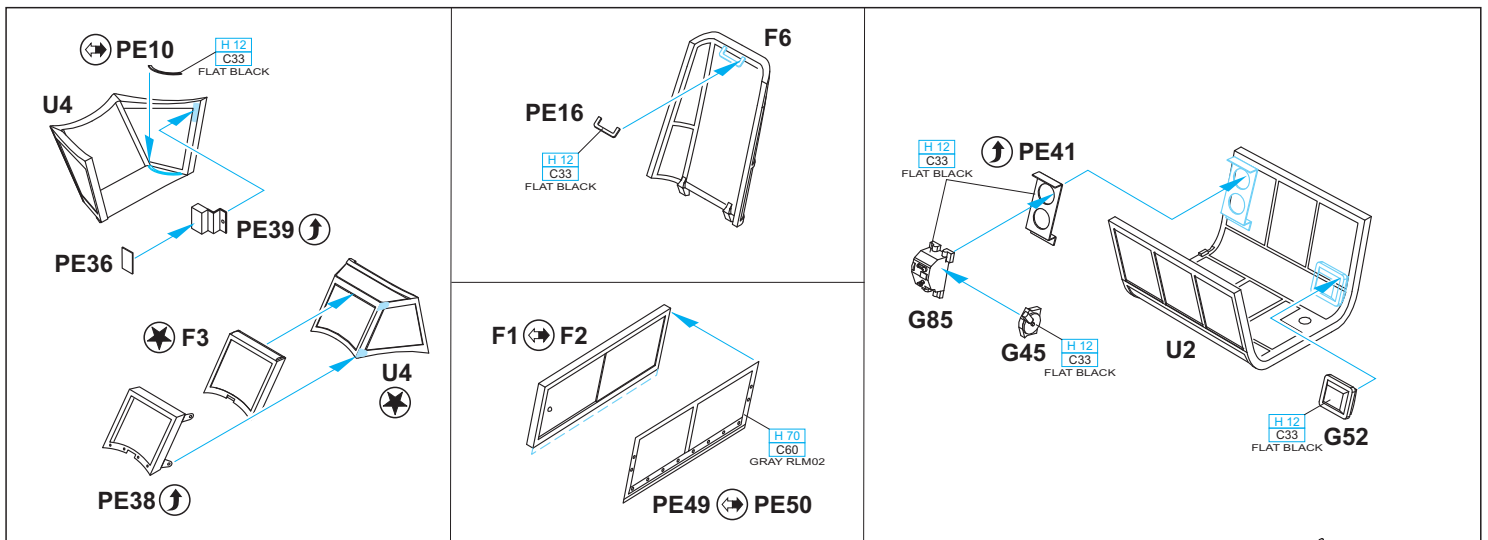

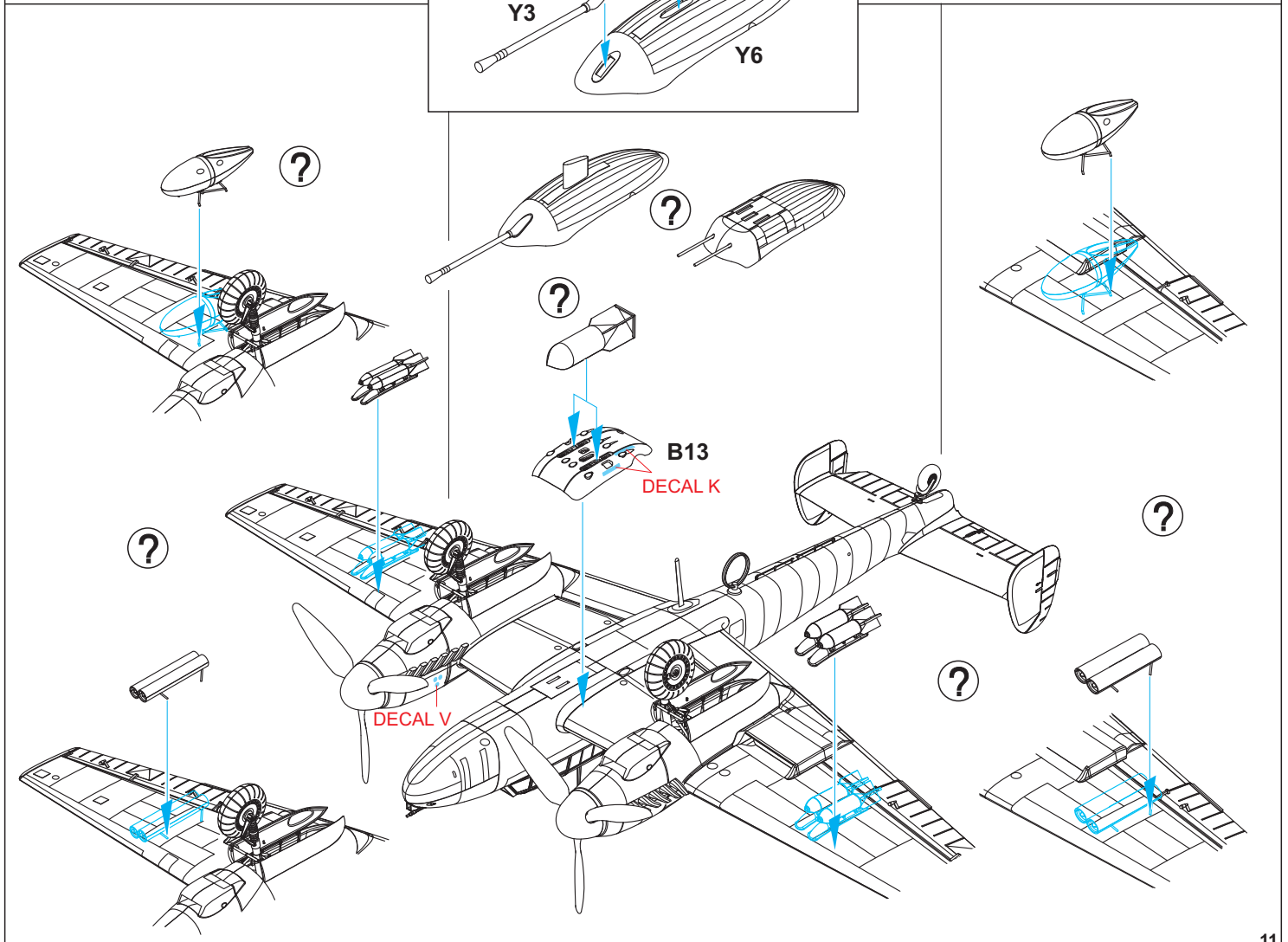
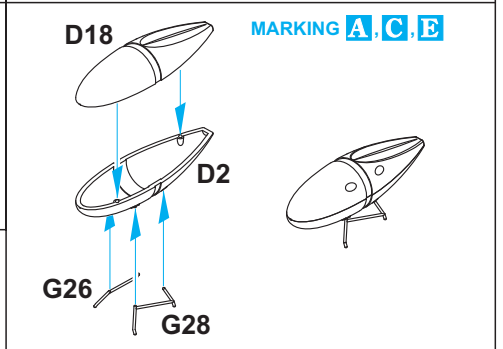
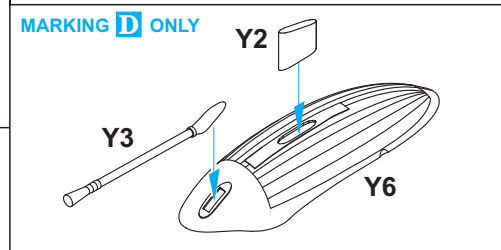
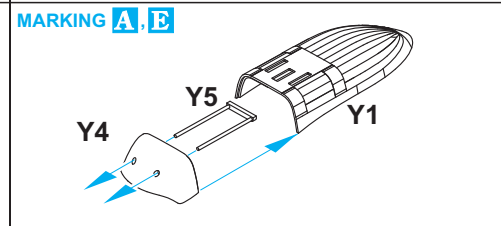
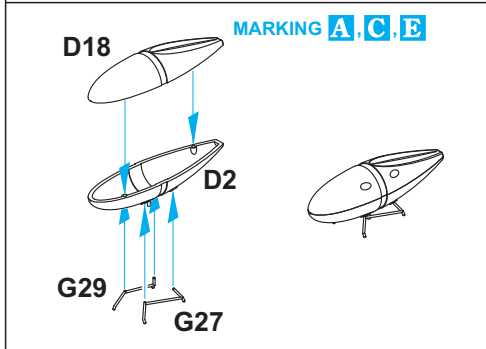
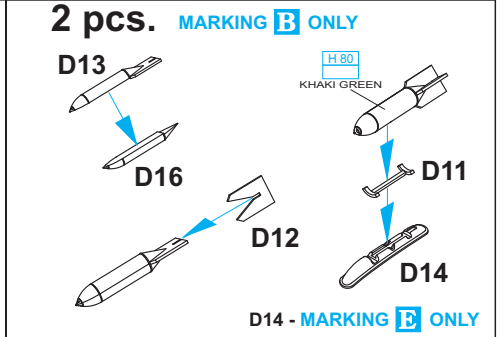
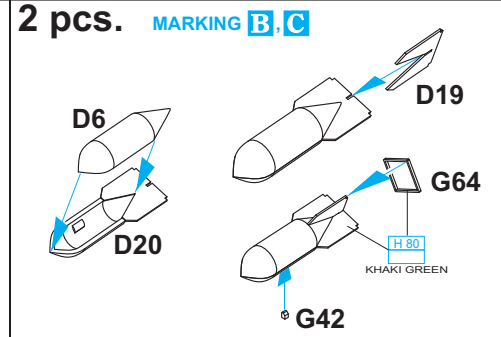
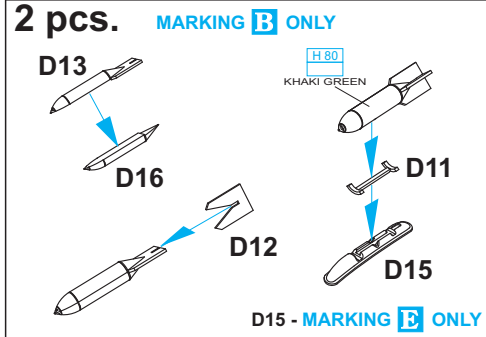
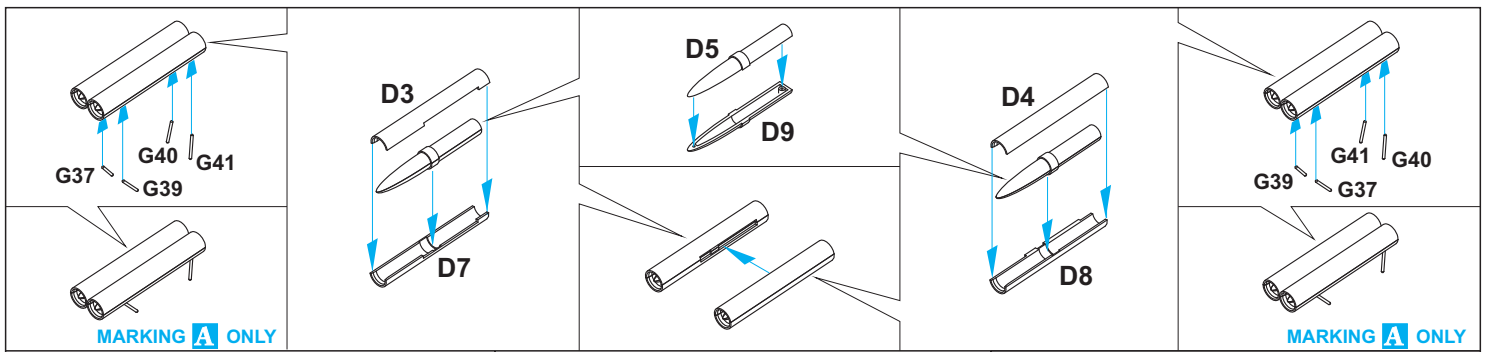

# A 5./ZG 1, Wells, Austria - Winter, 1943-44

As a component of 'Reichverteidigung' (Defense of the Reich), this rocket and tub-mounted 20 mm cannon armed Bf 110G-2 of Zerstoregeschwader 1 carries a standard camouflage composed of RLM 74/75/76. Notable is the quick recognition marking consisting of the wide white band, a relic of combat operations over the MTO. The red individual aircraft letter 'M', as the spinner tips, place this aircraft within the services of 5. Staffel of II. Gruppe. Atypically, the fuselage crosses lack black borders.

ZG 1, operating from airfields in Austria and Germany, took part in many engagements with American aircraft. These usually were from the 8th USAAF from England and from the 15th USAAF from Italy, and included the first major engagements between the USAAF and the Luftwaffe over Czech territory on February 22, 1944, in what became known as 'The Big Week'.

 ČESKOU VERZI TEXTU NALEZNETE NA [www.eduard.com/info/photos/8205](http://www.eduard.com/info/photos/8205)

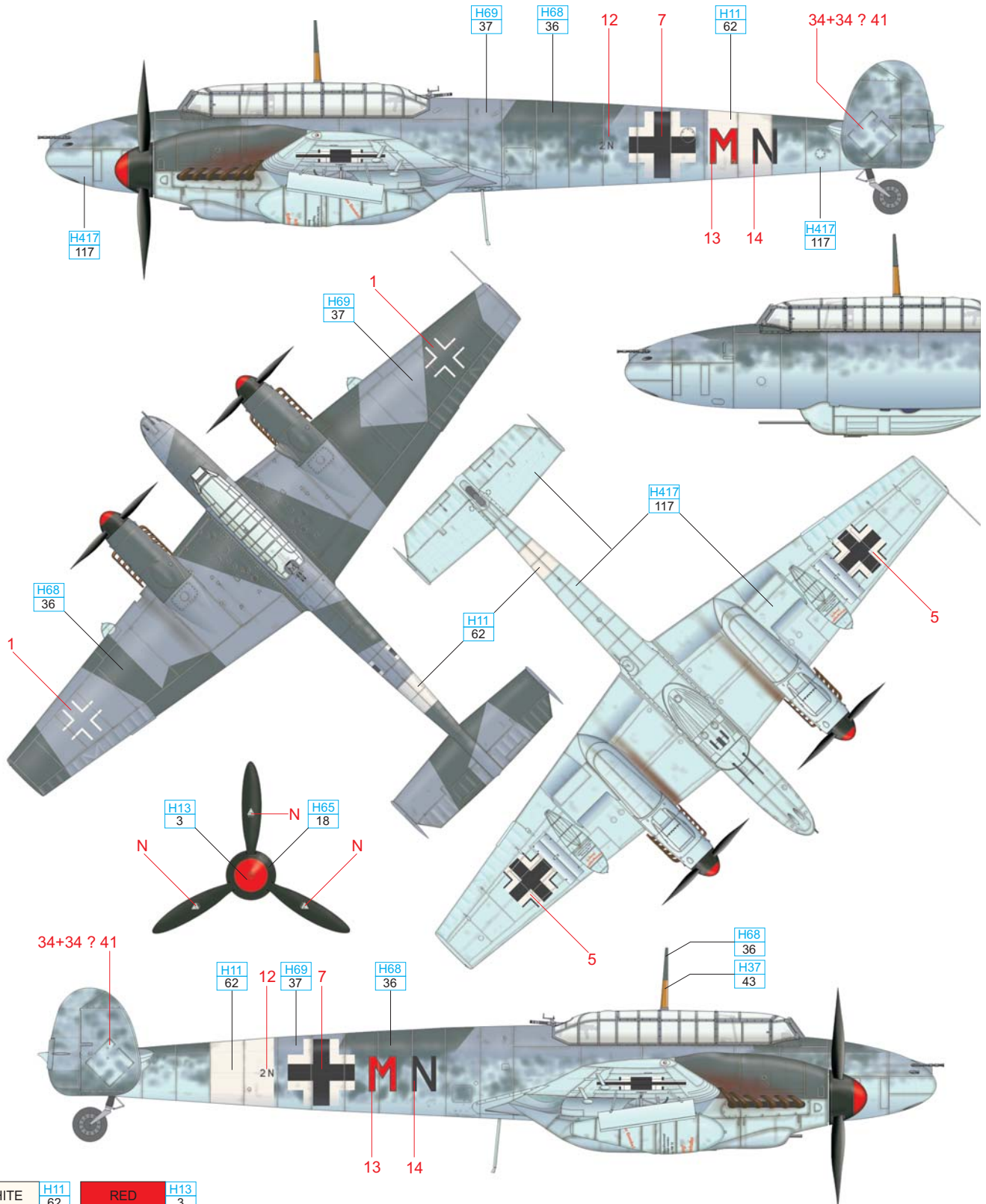

WHITE	H11 62	RED	H13 3
RLM 76	H417 117	RLM 75	H69 37
RLM 74	H68 36	RLM 70	H65 18
WOOD	H37 43		

## B 5./ZG 1, Monte Covino, Italy - Summer, 1943

One of the units to be withdrawn from the eastern front and activated in Italy in the spring of 1943 was ZG 1. Here, it operated first and foremost as a Jabo (fighter-bomber) unit. For this reason, the aircraft is pictured with bomb racks and dust filters. The yellow theatre markings from the eastern front were supplemented with a white MTO fuselage band that partially obscures the codes. Over the course of 1943, the unit's aircraft also acquired the very distinctive hornet emblem on the nose, associated with the Geschwader's name, 'Hornissen'.

This aircraft belongs to the same Staffel as '2N+MN' from profile 'A', but from several months prior, accounting for several marking differences. It is noteworthy how the fuselage codes differed with II./ZG 1: while this aircraft carries 'S9' from Erp.Gr.210, profile 'A' uses '2N' that at different times denoted II./ZG 1 and III./ZG 76. For reasons of different timeframes, there is also a variation in the size of the first part of the codes.



ČESKOU VERZI TEXTU NALEZNETE NA  
[www.eduard.com/info/photos/8205](http://www.eduard.com/info/photos/8205)

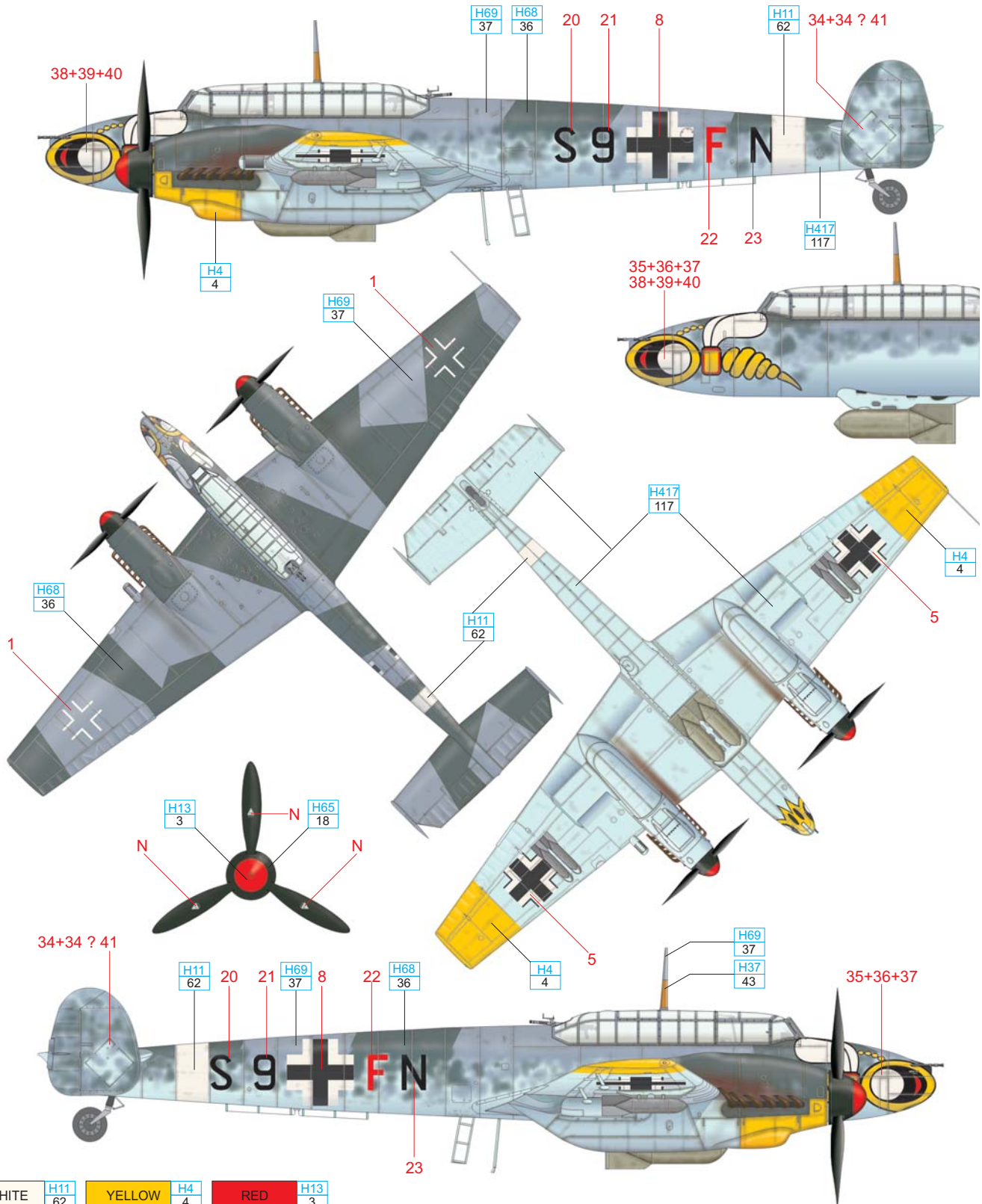

WHITE	H11 62	YELLOW	H4 4	RED	H13 3
-------	-----------	--------	---------	-----	----------

RLM 76	H417 117	RLM 75	H69 37	RLM 74	H68 36	RLM 70	H65 18	WOOD	H37 43
--------	-------------	--------	-----------	--------	-----------	--------	-----------	------	-----------

# C 10./ZG 26 (III.JG 5), Gossen, Norway - Spring, 1945

A combination of predominantly light colors RLM 76 and 75 make up the camouflage scheme of this aircraft belonging to III./JG 5, later ZG 26. Coming off the classic fighter role of JG 5 from northern Europe, these Bf110G-2s operated as fighter-bombers during the closing months of the war. Although JG 5 was not integrated into the 'Defense of the Reich' system, it did employ the fuselage bands associated with it. Black and yellow colors assigned to JG 5 appeared also on the pictured aircraft. Fuselage Balkenkreuz appear in their later guise, made up of only the white segments. The spinners carried a white spiral over RLM 70. The individual aircraft letter 'E' is repeated on the lower surfaces of the wing. Aircraft W.Nr. 210087 is sometimes interpreted as having been coded 1B+EU or 4A+EU, but the most recent evidence suggests that aircraft of 10.(Z)/JG 5 used the new code of 3U on redesignating as 10./IV./ZG 26.

 ČESKOU VERZI TEXTU NALEZNETE NA [www.eduard.com/info/photos/8205](http://www.eduard.com/info/photos/8205)

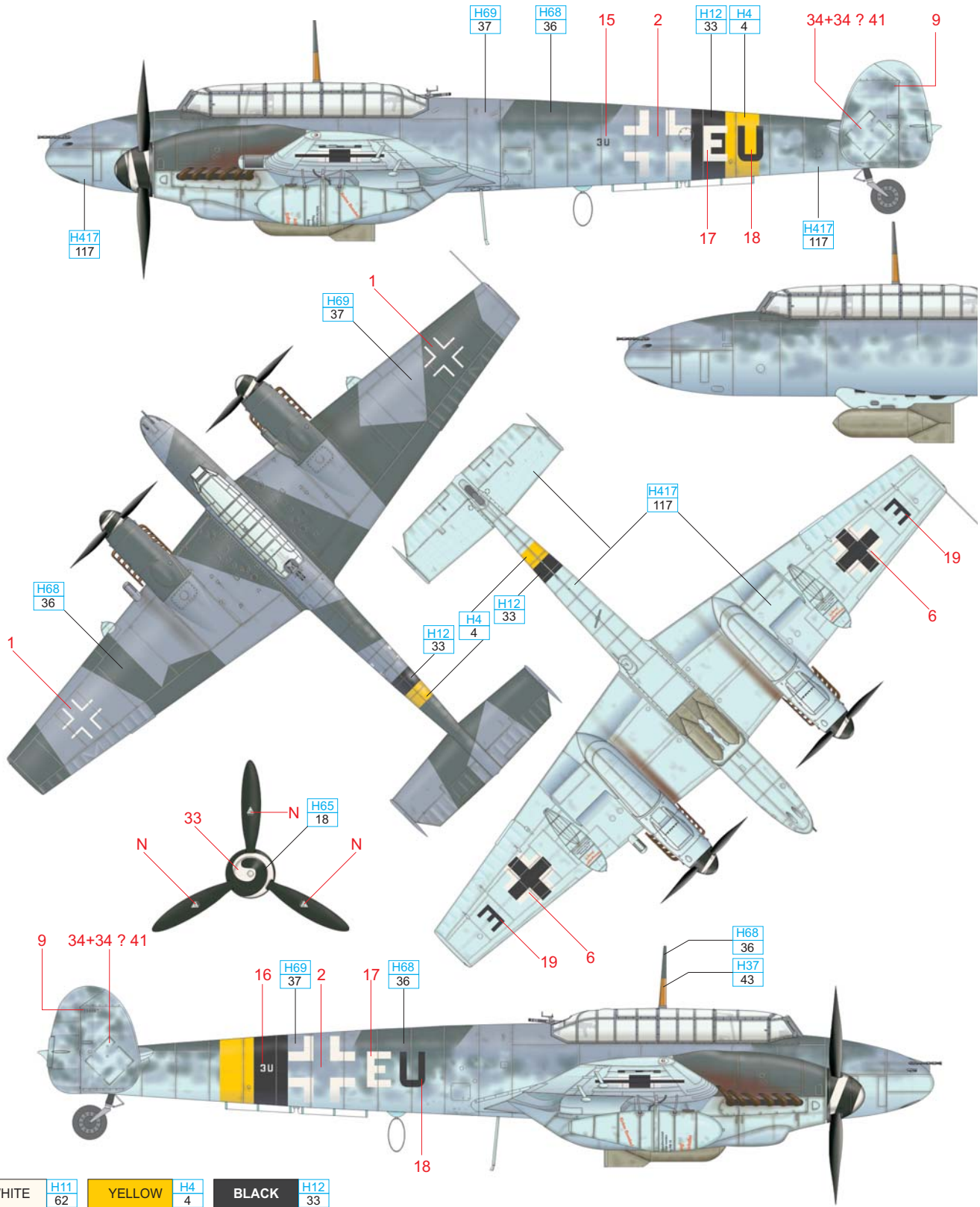

WHITE	H11 62	YELLOW	H4 4	BLACK	H12 33
RLM 76	H417 117	RLM 75	H69 37	RLM 74	H68 36
				RLM 70	H65 18
				WOOD	H37 43

## D 4./ZG 76, Prague, Czechoslovakia - Spring, 1944

Bf 110G-2/R1 with underslung 37 mm cannons were operated by ZG 76 within the 'Defense of the Reich' system from Kbely and Ruzyn airfields (Gbell and Rusin). This armament variation could have been devastating to the USAAF, but for the fact that its combat use rather complicated. The M5 modification using the Wfr.Gr. 21 was set up so that, due to weight savings, one rocket would be carried under each wing instead of two. The aircraft was a combination of R1 and R2 field modifications, and had the GM 1 (R2) system installed for high altitude performance. This was located in the rear cockpit and required the removal of the rear firing MG 82Z. Besides the national markings, fuselage codes, yellow fuselage band, and white-tipped spinners, the aircraft carries other identifying features. The fuselage cross has a wider white segment at the expense of the black centre. The individual aircraft letter 'K' is repeated under the wing. Atypically, yellow can be found on the rear fuselage in the vicinity of the tail surfaces.

Aircraft of ZG 76 with this armament configuration engaged allied formations on May 12, 1944, when the USAAF attacked Germany's largest refineries at STW Brux in Czechoslovakia, and thus initiated what became known as the 'Battle for Fuel'.

 ČESKOU VERZI TEXTU NALEZNETE NA [www.eduard.com/info/photos/8205](http://www.eduard.com/info/photos/8205)

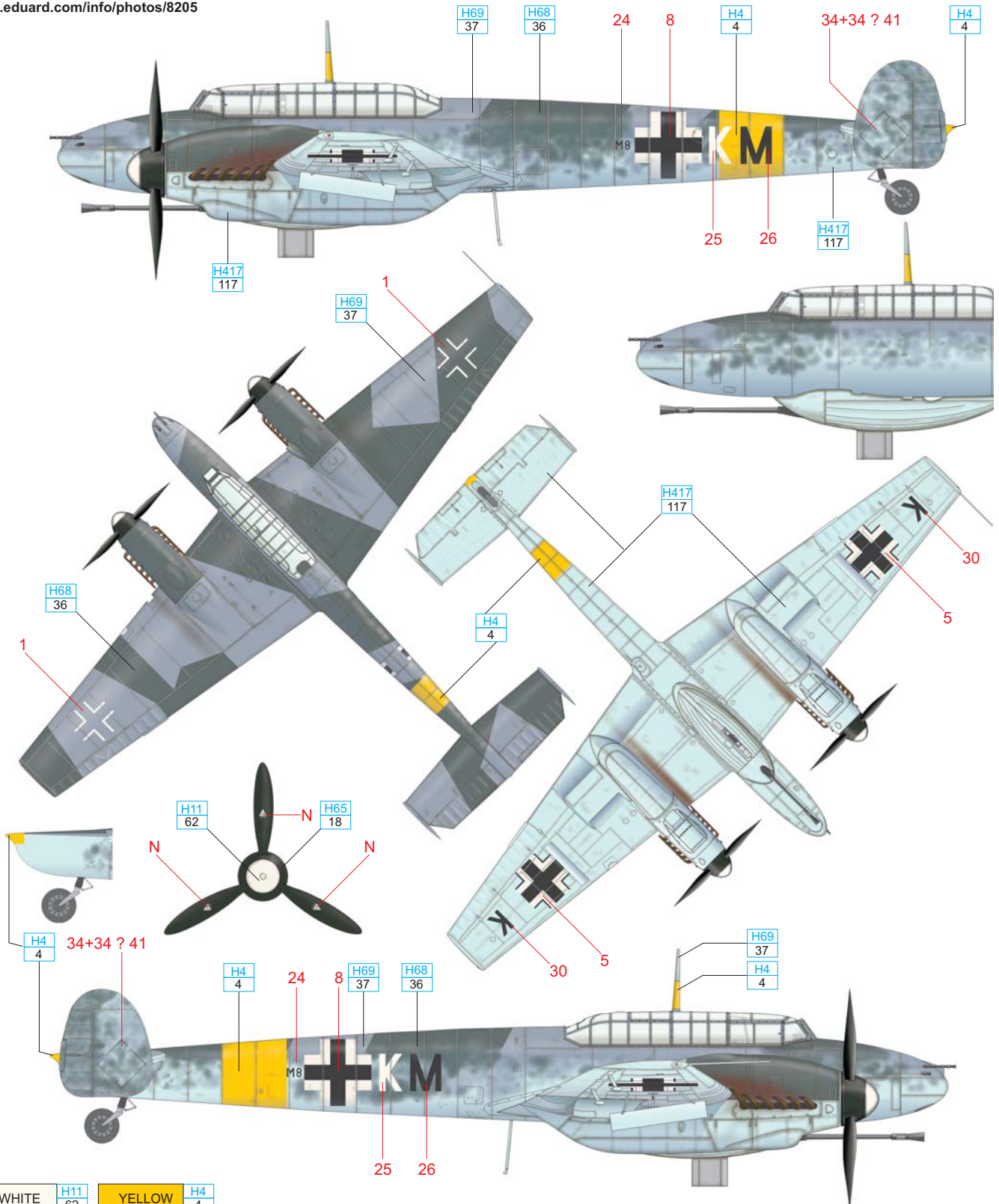

WHITE	H11 62	YELLOW	H4 4
-------	-----------	--------	---------

RLM 76	H417 117	RLM 75	H69 37	RLM 74	H68 36	RLM 70	H65 18
--------	-------------	--------	-----------	--------	-----------	--------	-----------

# E 5./NJG 200, Russia, 1943

Bf 110G-2s that found their way into the services of Nachtjagdgeschwader 200 on the eastern front were used in a way worth noting. The standard Bf 110G-2 modified to M1 standard (cannon tub under the fuselage) with no on-board radar or radio modifications, was used for night fighting using the guidance system of Freya and Wurzburg (Helle Nachtjagd). The character of the war on the eastern front was hardly conducive to this type of warfare, but the actions of NJG 200 illustrates the need for the protection of German assets and supply lines against Soviet night attacks.

Along with the mounting of anti-aircraft defenses on rail cars, NJG 200, as 'Eisenbahn Geschwader' was able to operate in required locations along sections of the eastern front. The aircraft carries a somewhat dark camouflage scheme of RLM 74/75/76 with yellow identification markings. The white fuselage Balkenkreuz is sprayed over irregular squiggles of 74, which is consistent with the time period of 1943-44. The red Staffel color appears on the spinner tips.

All of the presented schemes display an effort to darken the overall scheme with the additional spraying of irregular squiggles of RLM 74/75. These also serve to break up the well defined edge between the upper surface colors and the side RLM 76 surfaces. The inside surfaces of the vertical tails were treated in a similar fashion.



ČESKOU VERZI TEXTU NALEZNETE NA  
[www.eduard.com/info/photos/8205](http://www.eduard.com/info/photos/8205)

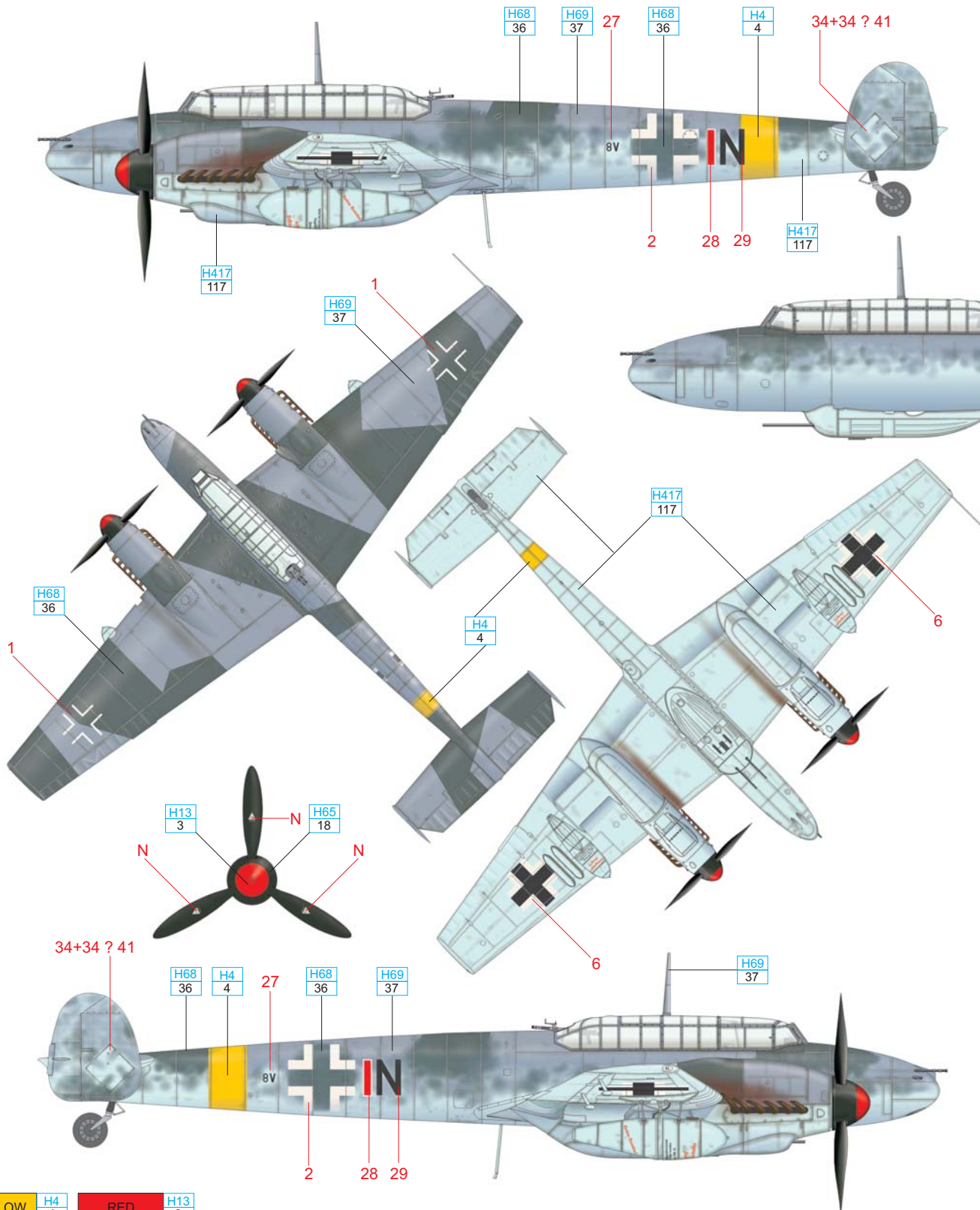

YELLOW	H4 4	RED	H13 3
RLM 76	H417 117	RLM 75	H69 37
RLM 74	H68 36	RLM 70	H65 18



# STENCIL DATA

