

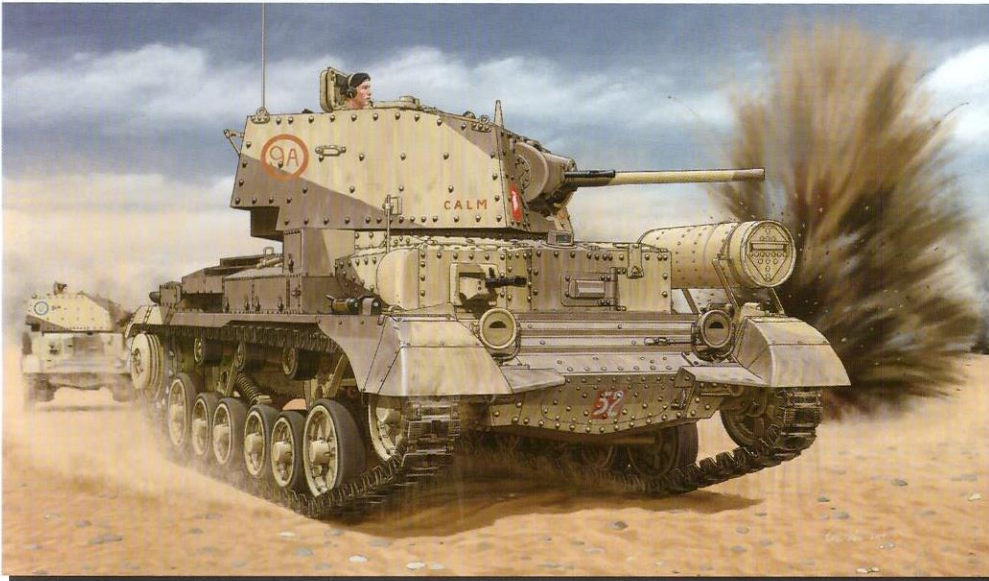

## 1/35 SCALE

## 35GM0002



### 繁體中文

1934年維克斯廠開始對A9 MKI型坦克進行改款的工作，基於作為重型步兵支援坦克的考慮，其原先只有15mm的裝甲是過於單薄和太輕。於是維克斯廠修訂A9的設計取消其前部兩個機槍炮塔，把正前方裝甲厚度加倍至最大30mm。重量增加到14.3噸，但由於仍使用同一款150bhp AEC商用卡車發動機，因而路速降低到26公里/小時。新的設計被命名為巡航坦克MKII A10，其試作型坦克在1936年完成，裝備有2磅反坦克炮和2挺維克斯303重機槍。雖然生產工作進展緩慢，但到1938年7月時仍有100台巡航坦克MKII A10 MKI坦克被生產出來。次年第二批次的75輛也被完成。到1939年維克斯廠又再修改設計，把原先的303重機槍用7.92mm的貝薩機槍所取代，新的改裝坦克被命名為巡航坦克MKII A10 Mk IA。A10用作為步兵支持的角色則其裝甲嫌太薄弱而作為巡航坦克使用則速度太慢了。這樣的設計實則是不很理想的，稍後其由於軍方沒有進一步的訂單而被迫放棄生產。

### 简体中文

1934年维克斯厂开始对A9 MKI型坦克进行改款的工作，基于作为重型步兵支持坦克的考虑，其原先只有15mm的装甲是过于单薄和太轻。于是维克斯厂修订A9的设计取消其前部两个机枪炮塔，把正前方装甲厚度加倍至最大30mm。重量增加到14.3吨，但由于仍使用同一款150bhp AEC商用卡车发动机，因而路速降低到26公里/小时。新的设计被命名为巡航坦克MKII A10，其试作型坦克在1936年完成，装备有2磅反坦克炮和2挺维克斯303重机枪。虽然生产工作进展缓慢，但到1938年7月时仍有100台巡航坦克MKII A10 MKI坦克被生产出来。次年第二批次的75辆也被完成。到1939年维克斯厂又再修改设计，把原先的303重机枪用7.92mm的贝萨机枪所取代，新的改装坦克被命名为巡航坦克MKII A10 Mk IA。A10用作为步兵支持的角色则其装甲嫌太薄弱而作为巡航坦克使用则速度太慢了。这样的设计实则是不很理想的，稍后其由于军方没有进一步的订单而被迫放弃生产。

### English

In 1934 Vickers began work on the Cruiser Tank Mk. I, A9, but already its 15mm armour was considered to light and a heavier tank was suggested for infantry support. Vickers revised the A9 design by removing the two machine gun sub-turrets and doubling the armour thickness to a maximum of 30mm. Weight increased to 14.3 tons but the same 150bhp AEC engine was used and the road speed was reduced to 26 km/h. The new design was approved as the Cruiser Tank Mk. II, A10 and the first pilot tank was ready by 1936 armed with a 2 Pounder anti-tank gun and 2 x Vickers .303 machine guns. However work proceeded slowly and the A10 was not produced until July 1938 when 100 A10 Mk. I tanks were ordered. This was followed by a second order of 75 tanks the following year. In 1939 the Vickers machine gun was replaced by the 7.92mm Besa, tanks mounting the weapon were designated the A10 Mk. IA. The A10 was seen as too lightly armoured for infantry support and too slow for a Cruiser Tank. As such the design was deemed unsatisfactory and no further orders were placed.

Story by Phil Greenwood

### Deutsch

Im Jahr 1934 begann Vickers die Arbeit an dem Cruiser Tank MkI, A9, aber schon seine 15mm Panzerung wurde als zu schwach erachtet und ein schwerer Panzer für die Infanterieunterstützung wurde gefordert. Vickers überarbeitete den A9-Entwurf indem man die beiden Maschinengewehr-Untertürme entfernte und die Panzerung auf ein Mazimum von 30mm verdoppelte. Das Gewicht erhöhte sich auf 14,3 Tonnen, aber es wurde der gleiche AEC Motor mit 150 PS wurde verwendet und die Fahrgeschwindigkeit wurde auf 26 km / h reduziert. Das neue Design wurde als der Cruiser-Tank MkII, A10 genehmigt und der erste Prototyp war 1936 fertig und mit einer 2 Pounder Panzerabwehrkanone und 2 x Vickers .303 Maschinengewehren bewaffnet. Allerdings ging die Arbeit langsam voran und die A10 waren erst im Juli 1938 zur Produktion bereit, als 100 A10 MkI Panzer bestellt wurden. Darauf folgte eine zweite Bestellung von 75 Panzern im folgenden Jahr. Im Jahr 1939 wurden die Vichers Maschinengewehre durch die 7,92mm Besa ersetzt, Panzer, die diese Waffen eingebaut hatten, wurden als A10 MkIA bezeichnet. Die A10 wurde als zu leicht gepanzert für Infanterie-Unterstützung und zu langsam für einen Cruiser-Tank bewertet. Daher wurde das Design als unbefriedigend erachtet und es wurden keine weiteren Aufträge erteilt.

Translation by Thomas Hartwig

### 日文

1934年ヴィッカーズ社は巡航戦車マークIA 9の設計を始めますがすでに15ミリの装甲厚では脆弱で歩兵支援のより重厚な戦車が示唆されました。ピッカーズ社は最大30ミリの2倍の装甲厚とA9戦車の設計を2個の副砲塔を廃止する変更を施しました。増加した総重量は14.3トンでしたが同じAEC社製150馬力ガソリンエンジンを搭載したため最高時速は26キロまで低下しました。新設計の車両は巡航戦車マークIIA 10として承認され、最初の試作車は1936年に完成。2ポンド砲を主砲として2機の303ヴィッカーズ水冷機関銃が搭載されました。しかし生産は1938年まで遅れ、100両が発注され、その翌年75両追加発注されました。1939年ヴィッカーズ機関銃はベサ7.92ミリに変換され、A10マークIAとして制式名称されました。A10は歩兵支援としては軽装甲で巡航戦車としては速度が足りませんでした。このような欠点で順次の採用は見直されてしまいました。

### READ BEFORE ASSEMBLY:

1. Study and understand these instructions thoroughly before beginning assembly.
2. When needed, remove photo etch parts carefully using a modeling knife or photo etch sprue cutter, be careful not to damage or lose small parts.
3. Take extra care in handling photo etch parts in order to avoid injury.
4. Apply instant cement sparingly to photo etch parts were instructed.
5. Tools recommended (not included in kit): Plastic and instant cements, sprue cutters, long nose pliers, modeling knife, small files, tweezers, pin vise & scissors, Soft cloth and sandpaper will also assist in construction.
6. Glue and paint are not included in the kit. Use plastic cement and hobby paints only. Color guide for purchasing paint is included in the kit.

### VOR DEM ZUSAMMENBAU LESEN:

1. Studieren Sie die Anleitung gründlich und machen Sie sich damit vertraut.
2. Fotoätzteile mit scharfem Messer oder passender Zange ablösen und dabei Beschädigungen und Verlust vermeiden.
3. Vorsicht vor Verletzungen bei der Arbeit mit Fotoätzteilen.
4. Sekundenkleber sparsam an gezeigten Stellen auftragen.
5. Empfohlene Werkzeuge (nicht enthalten): Plastik- und Sekundenkleber, Kneifzange, Kombizange, Modellbaumesser, kleine Feilen, Pinzette, Handbohrer, Schere und Schleifpapier.
6. Kleber und Farben sind nicht enthalten. Nur für Modellbau geeignete Farben verwenden. Farbangaben siehe Bauanleitung.

### 在組裝前先過目以下事項:

1. 在組裝前請先理解一下說明書的內容。
2. 在處理蝕刻片零件時最好使用專用模型工具刀或剪刀切割，小心處理細小零件以免掉失。
3. 蝕刻片零件邊沿比較鋒利，處理時應要小心以免受傷。
4. 黏合蝕刻片零件應使用快乾膠水。
5. 組裝模型建議使用正確工具（不包含在套件內）如：- 模型膠水、快乾膠水、剪鉗、長鼻鉗鉗、模型工具刀、小鐵子、柔軟棉布及砂紙去協助制作。
6. 專用的模型油漆及膠水均不包含在套件內，必須另外購買。正確的塗色指示已包含在套件裏。

### 組立前にお読み下さい:

1. 組立前に説明書を理解とよくご覧下さい。
2. エッチングパーツを切り離すときは模型用ナイフまたはニッパを使用し破損や紛失しないようにご注意ください。
3. 特にエッチングパーツの取り扱いの際、怪我にはご注意ください。
4. 瞬間接着剤の適宜な使用がエッチングパーツの接着に適しています。
5. 製作に必要な工具類: プラスチックモデル用また瞬間接着剤、プラキット用ニッパ、ラジオペンチ、模型用ナイフ、精密工作用金製やすり、ピンセット、ピンバイス(ドリル)、鉸、ウエスなどの布類、紙やすりなど。工作に関してご留意をお勧めします。
6. 接着剤とモデルカラーはキットに含まれていません。プラキット専用の接着剤とモデルカラーを使用して下さい。塗装ガイドと各メーカー指定色はキットに表記があります。

### CAUTION:

1. When you use glue or paint do not use near a open flame and sue in a well-ventilated room.
2. Cut the parts off properly and throw waste parts into dustbox at once.
3. Keep all parts out of small children. Children must not be allowed to put any parts in their mouths, or pull plastic bags over their head.
4. Do not play with the parts for any other purpose, as some parts may be to sharp. More caution and care needed for families with infants.

### ACHTUNG:

1. Kleber und Farben nicht in der Nähe von offenen Flammen verwenden. Auf ausreichende Belüftung achten.
2. Teile sauber abtrennen und Reste umgehend beseitigen.
3. Alle Teile und Plastiktüten außer Reichweite von Kleinkindern aufbewahren.
4. Teile aufgrund von scharfen Kanten nicht für andere Zwecke verwenden.

### 注意:

1. 當組裝模型時應遠離火種及在空氣流通的房間內進行。
2. 廢置膠料應掉棄在環保回收的垃圾箱內。
3. 由於模型套件有許多細小零件，請勿讓小孩接觸以免產生誤吞之危險。也別讓小孩把包裝膠件之透明塑料袋套在頭上，這很容易引起窒息。
4. 由於零件有不少尖角部份，請勿把玩及作其他用途，請注意及小心保護你的家人。

### ご注意:

1. 接着剤と塗装を行う際は裸火の近くで行わないで下さい。そして部屋の換気を良くして下さい。
2. 正しくパーツを切り離し際は不要なパーツは速やかに廃棄して下さい。
3. 小さなお子様はパーツを誤嚥したり、梱包のビニール袋を被り窒息する恐れがあり危険です。小さなお子様の手に届かないよう注意ください。
4. 模型製作以外の目的で本キットパーツを玩具などに使用しないで下さい。パーツの中には鋭角なものもあり危険です。ご家族のため、細心の注意を心がけて下さい。

### ICON INSTRUCTION :



### Tools recommended



Cement



Cyanoacrylate glue



Cutter

Pin vise



Modeling knife



Tweezer



### Correct method for applying decals: Hinweise zum anbringen der decal

1. Clean model parts surface with wet cloth.  
Entsprechende Stellen am Modell feucht reinigen.
2. Cut out the decal parts and dip them in cold water for 15 -20 seconds.  
Decal ausschneiden und für 15-20 Sek. ins Wasser legen.

3. Place it on correct position of the model kit.  
Decal an der richtigen Stelle auflegen.
4. Slide off the decal from the base paper on to the model kit surface with a cotton stick.  
Decal mit Wattestäbchen festhalten und Papier darunter wegziehen.
5. When decal get dry then complete.  
Decal mit Papiertuch andrücken und trocknen.

### 正確使用水貼紙的方法:

1. 將需要貼上水貼之部位表面擦乾淨。
2. 將所需之貼紙剪下泡在清水裡約15至20秒。
3. 將濕透之貼紙取出置放於正確之位置旁。
4. 用棉花棒輕推貼紙表面使其從底紙滑出至模型表面之正確位置。
5. 待其自然幹透後即完成。

# Sprue Parts List

**C** × 1

**D** × 1

**Hc** × 1

**Ea** × 1

**Eb** × 1

**Fh** × 4

**Gc** × 1

**F** × 1

**Ge** × 1

**Ec** × 2

**Fj** × 7

**Fc** × 2

**Gb** × 1

**Fg** × 3

**Hd** × 1

**Fa** × 6

**Fb** × 2

**Pe** × 1

电线  
Electric wire

绳子  
Cordage

paster × 1

OPTION 1  
① ② ③ ④ ⑤ ⑥ ⑦ ⑧ ⑨ ⑩ ⑪ ⑫ ⑬ ⑭ ⑮ ⑯ ⑰ ⑱ ⑲ ⑲ ⑲

OPTION 2  
① ② ③ ④ ⑤ ⑥ ⑦ ⑧ ⑨ ⑩ ⑪ ⑫ ⑬ ⑭ ⑮ ⑯ ⑰ ⑱ ⑲ ⑲ ⑲

OPTION 3  
① ② ③ ④ ⑤ ⑥ ⑦ ⑧ ⑨ ⑩ ⑪ ⑫ ⑬ ⑭ ⑮ ⑯ ⑰ ⑱ ⑲ ⑲ ⑲

OPTION 4  
① ② ③ ④ ⑤ ⑥ ⑦ ⑧ ⑨ ⑩ ⑪ ⑫ ⑬ ⑭ ⑮ ⑯ ⑰ ⑱ ⑲ ⑲ ⑲

OPTION 5  
① ② ③ ④ ⑤ ⑥ ⑦ ⑧ ⑨ ⑩ ⑪ ⑫ ⑬ ⑭ ⑮ ⑯ ⑰ ⑱ ⑲ ⑲ ⑲

Gecko Models  
35GM002 Cruiser Tank A10 Mk.IA

Gecko Models  
35GM001/35GM002/35GM005

1



Interior Colour : Silver

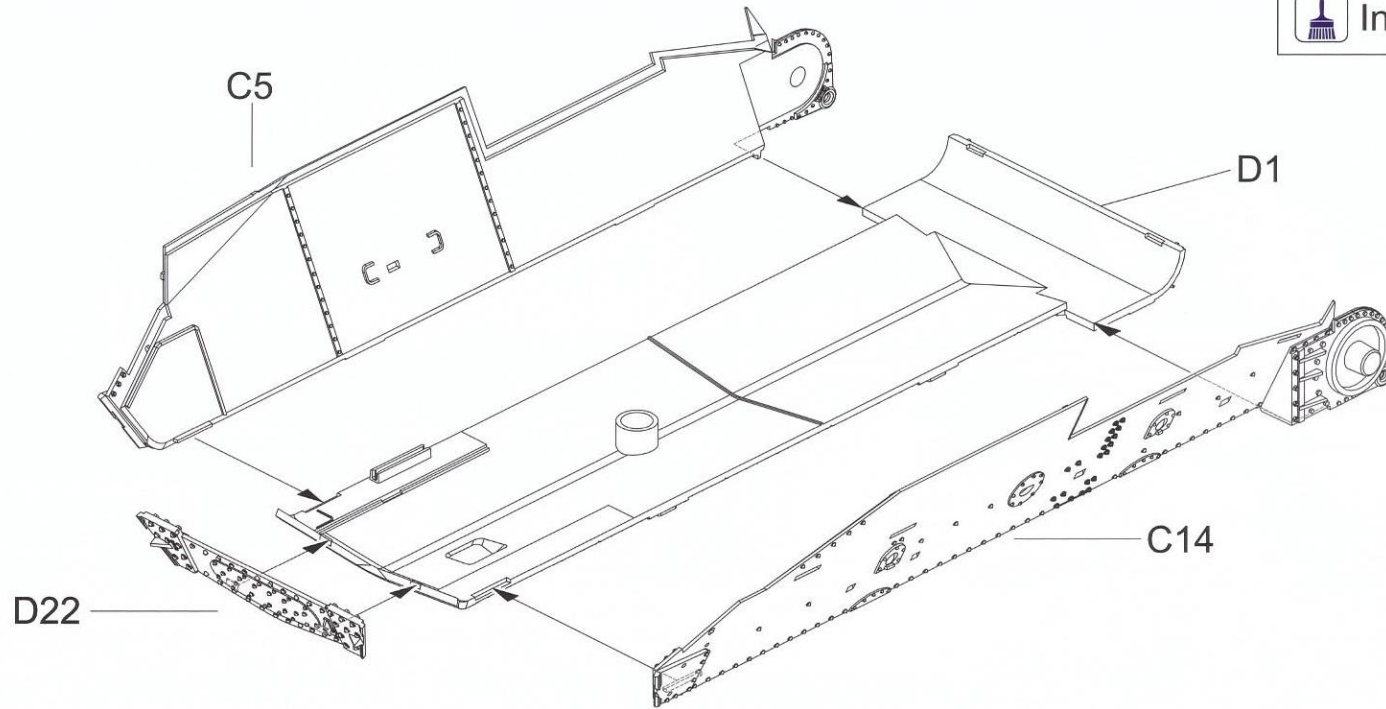

2



Semi-Gloss Black

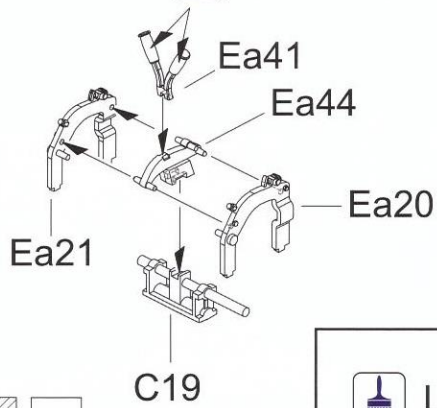

Step. a



Semi-Gloss Black

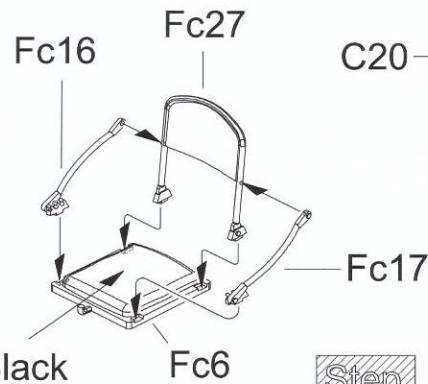

Step. b x2

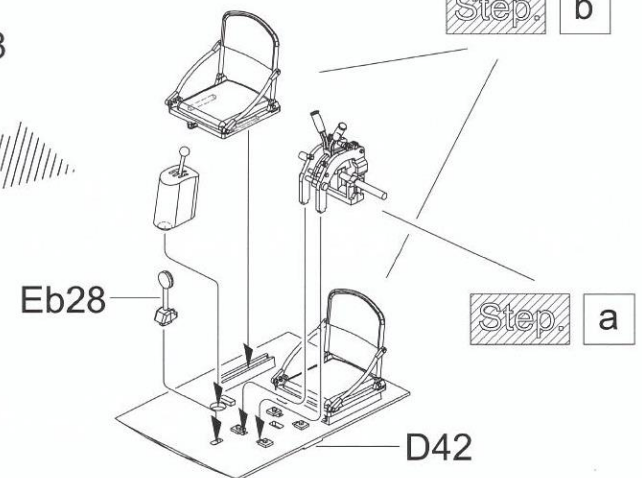

3

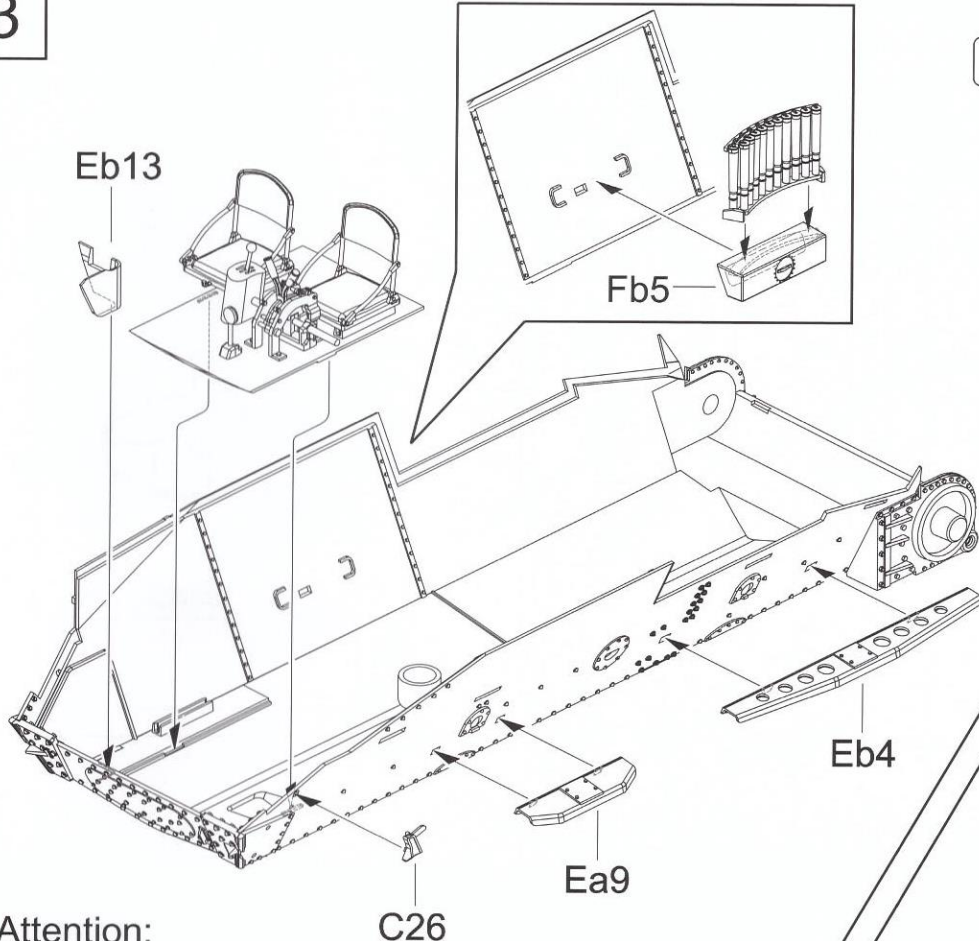

Attention:  
Do not cut out the  
Proturding Point  
for the parts fixed  
use

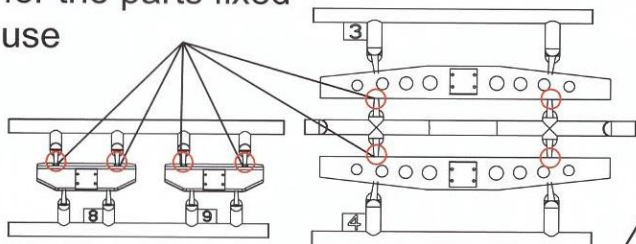

Gold Leaf

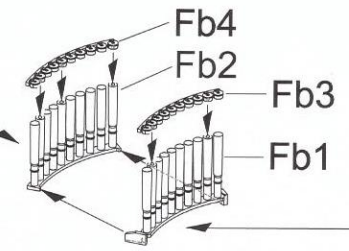

x2



Copper

4

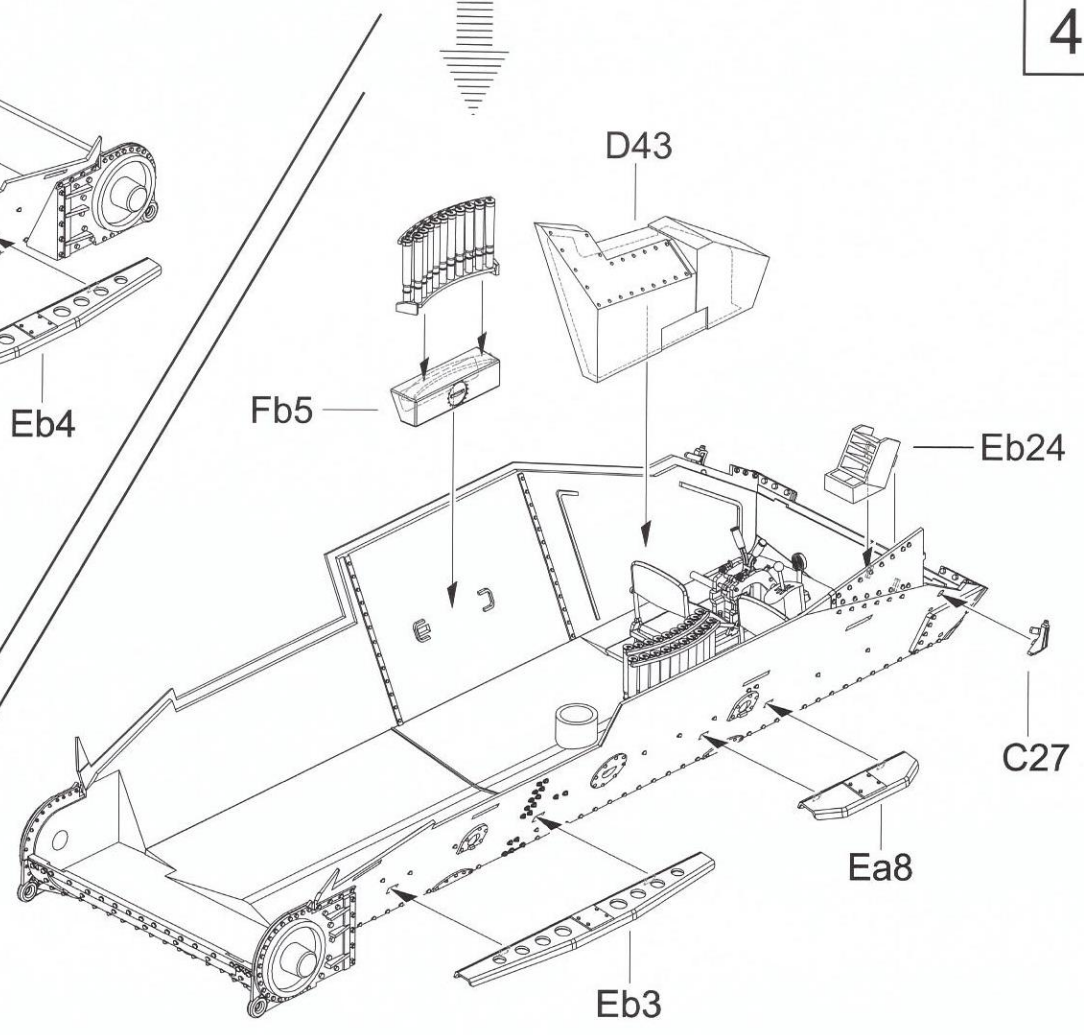

5

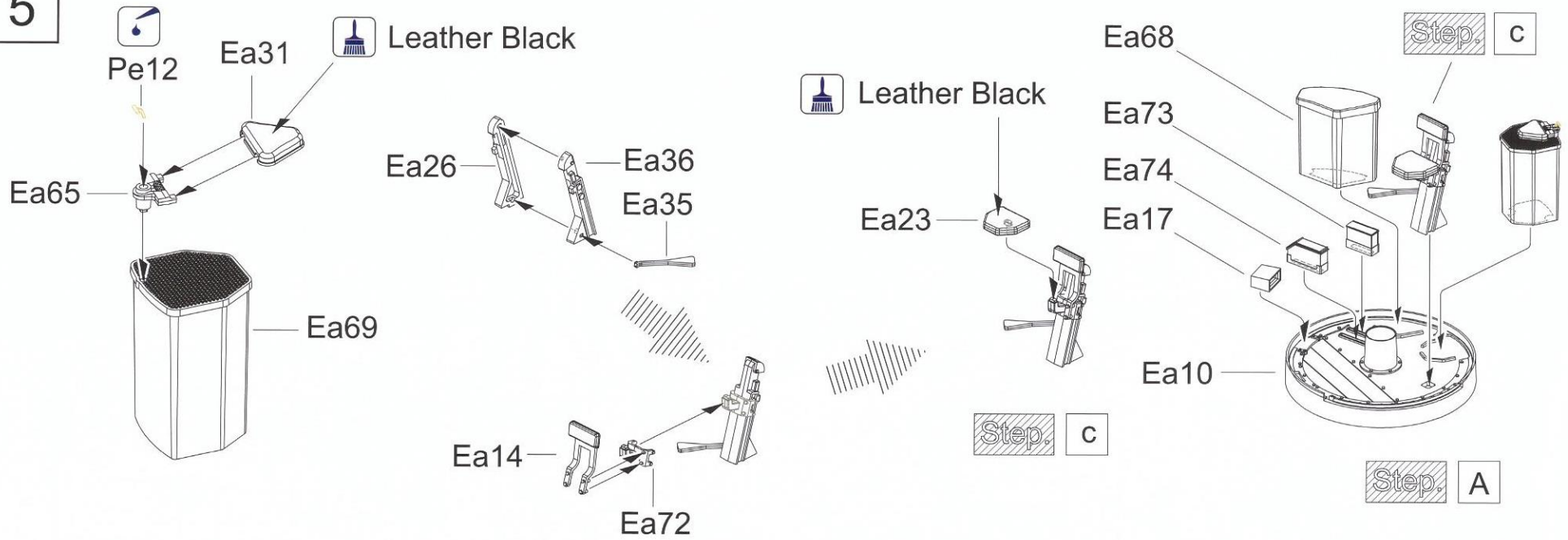

6

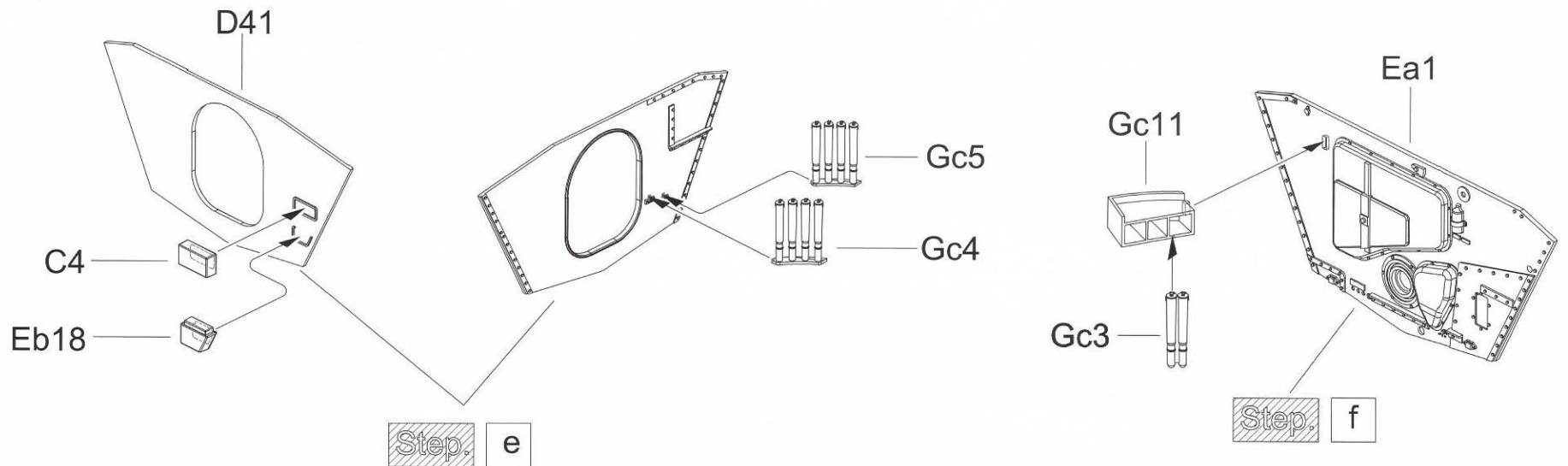

7

Step. e

Step. f

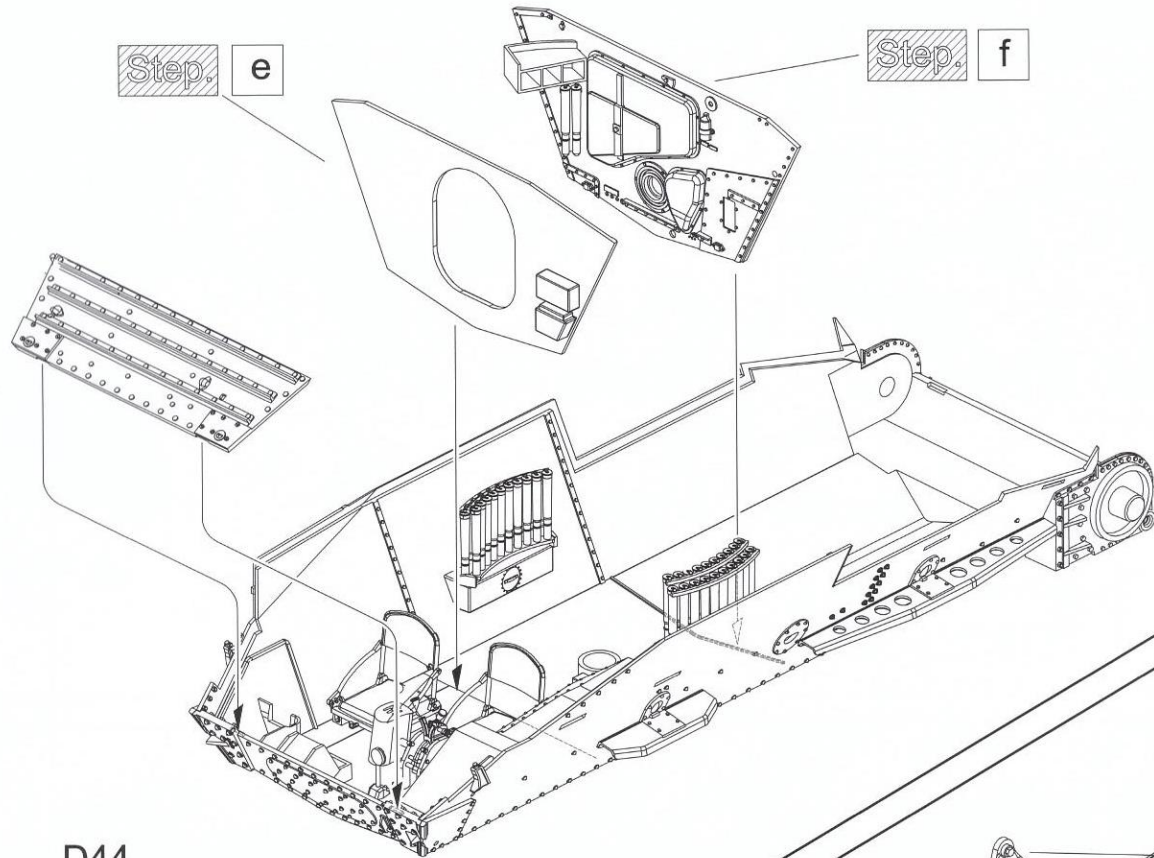

8

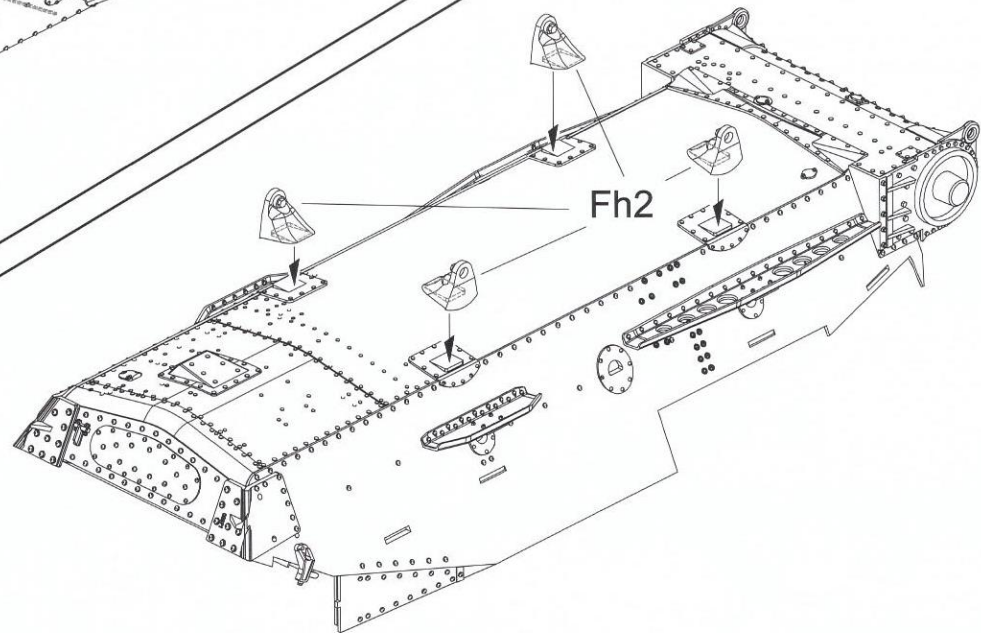
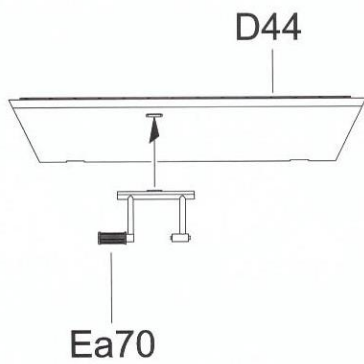

9

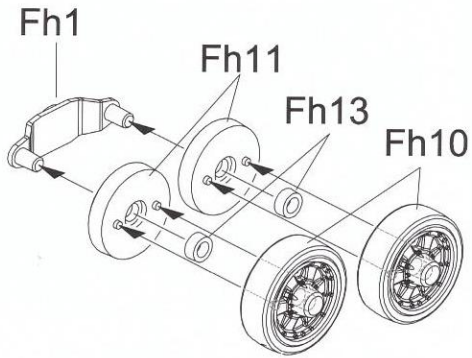

Step g x4

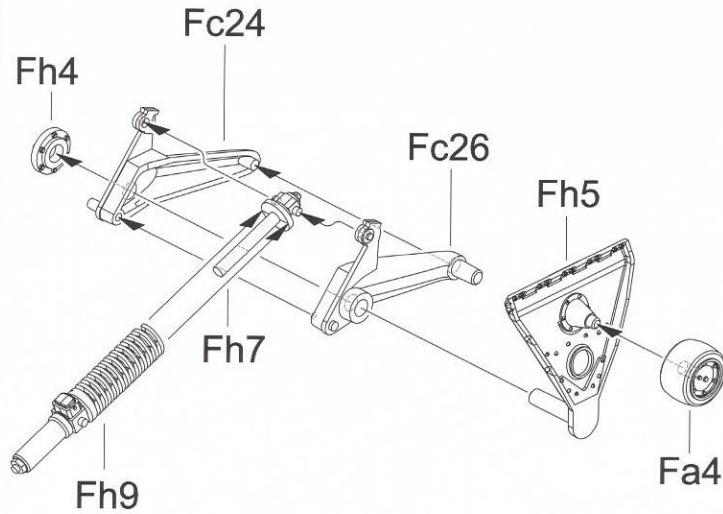

**Moveable Suspension System**  
 ☆ Be Careful Do Not Put Too Much Glue

Step D x2

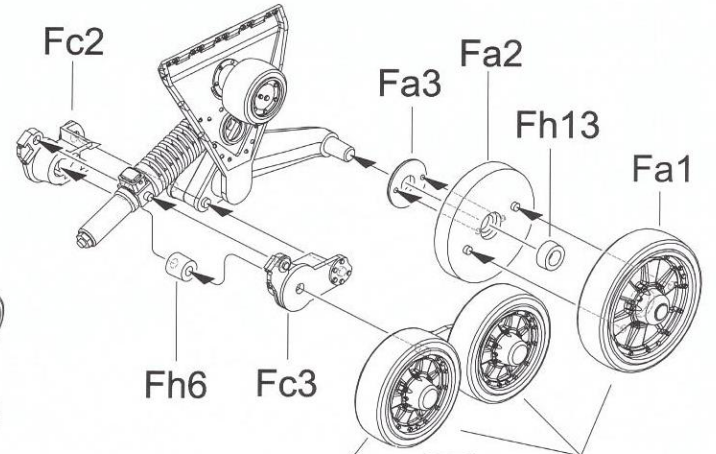

Step g

Rubber Black

10

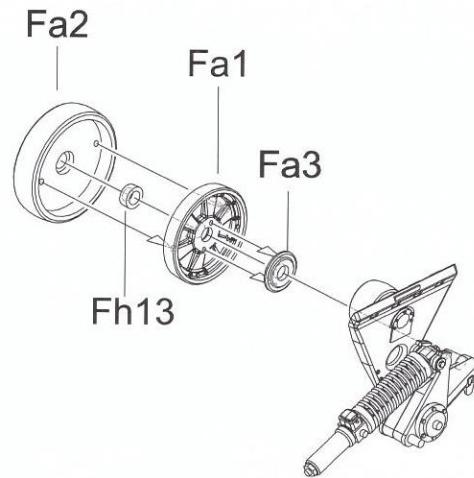
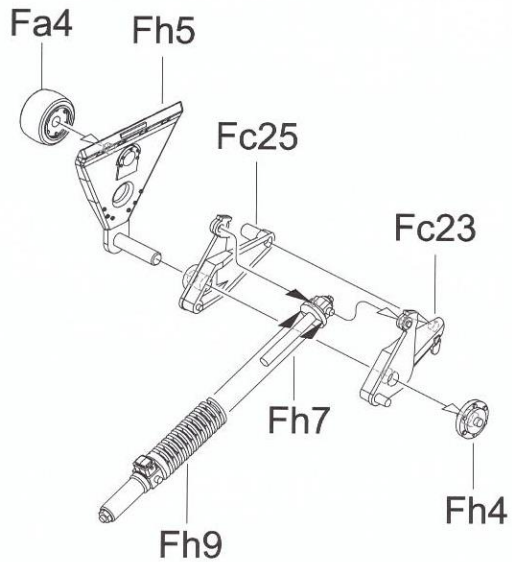

Step g

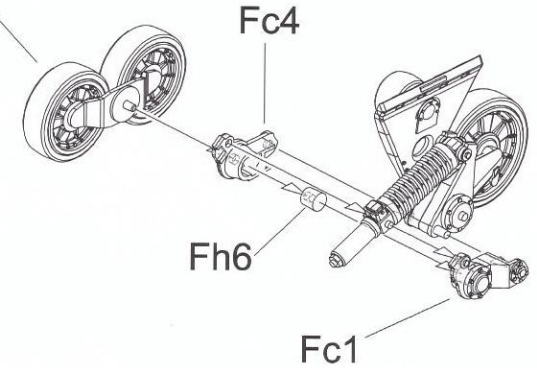

Step E x2



11

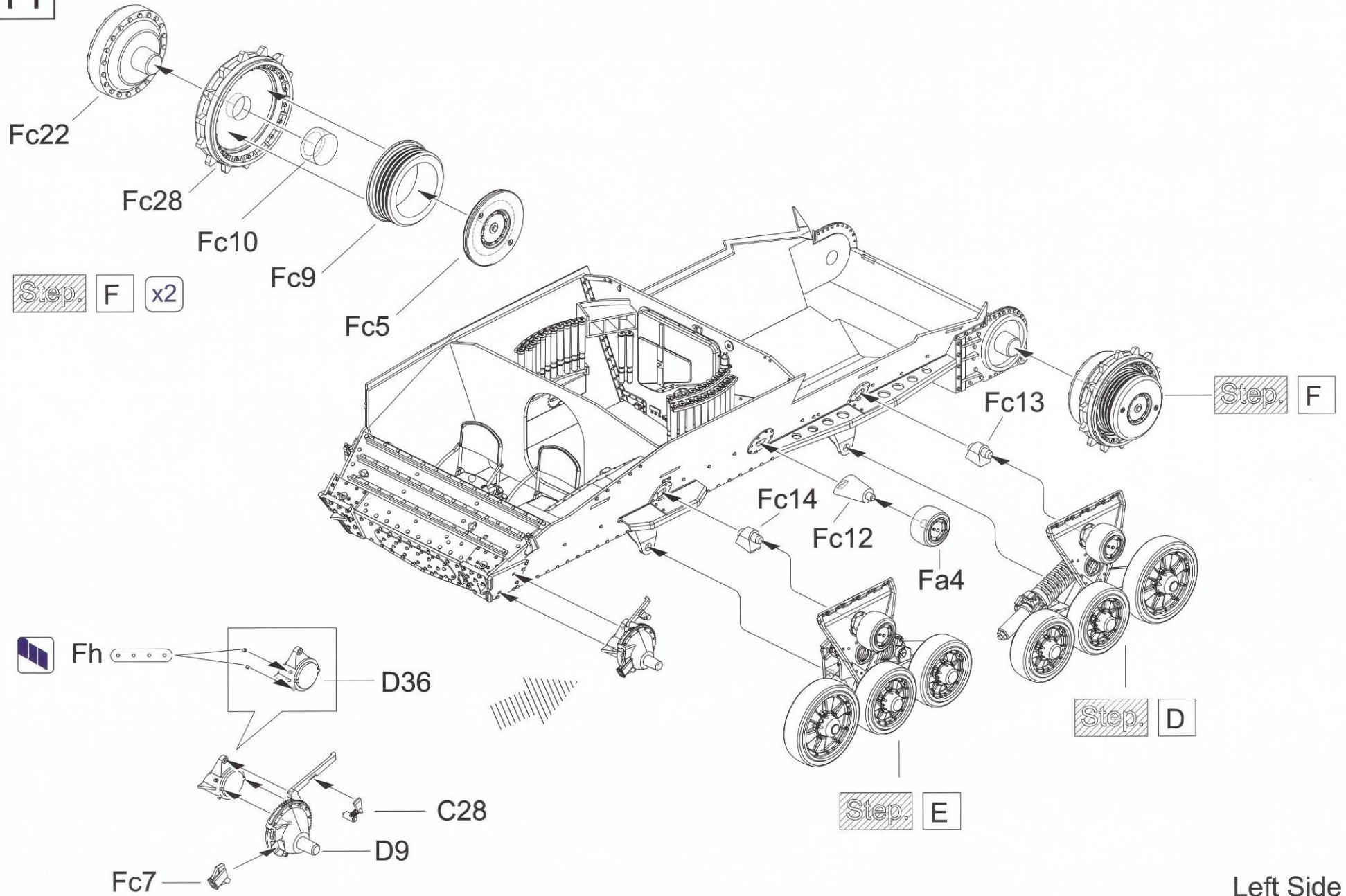

Left Side

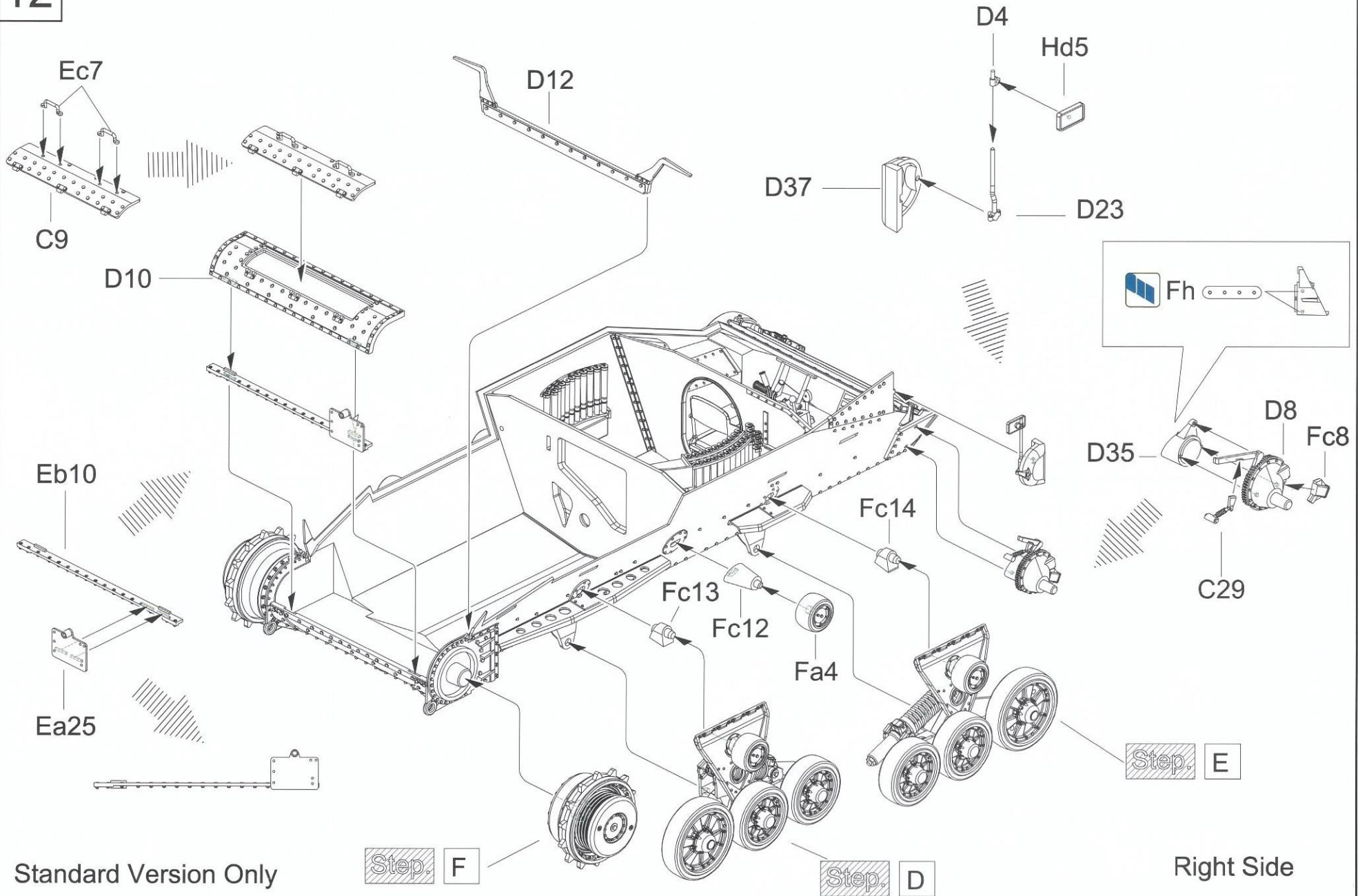

Standard Version Only

Right Side

13

Gloss Silver

Drill a 0.5mm hole

Gloss Silver

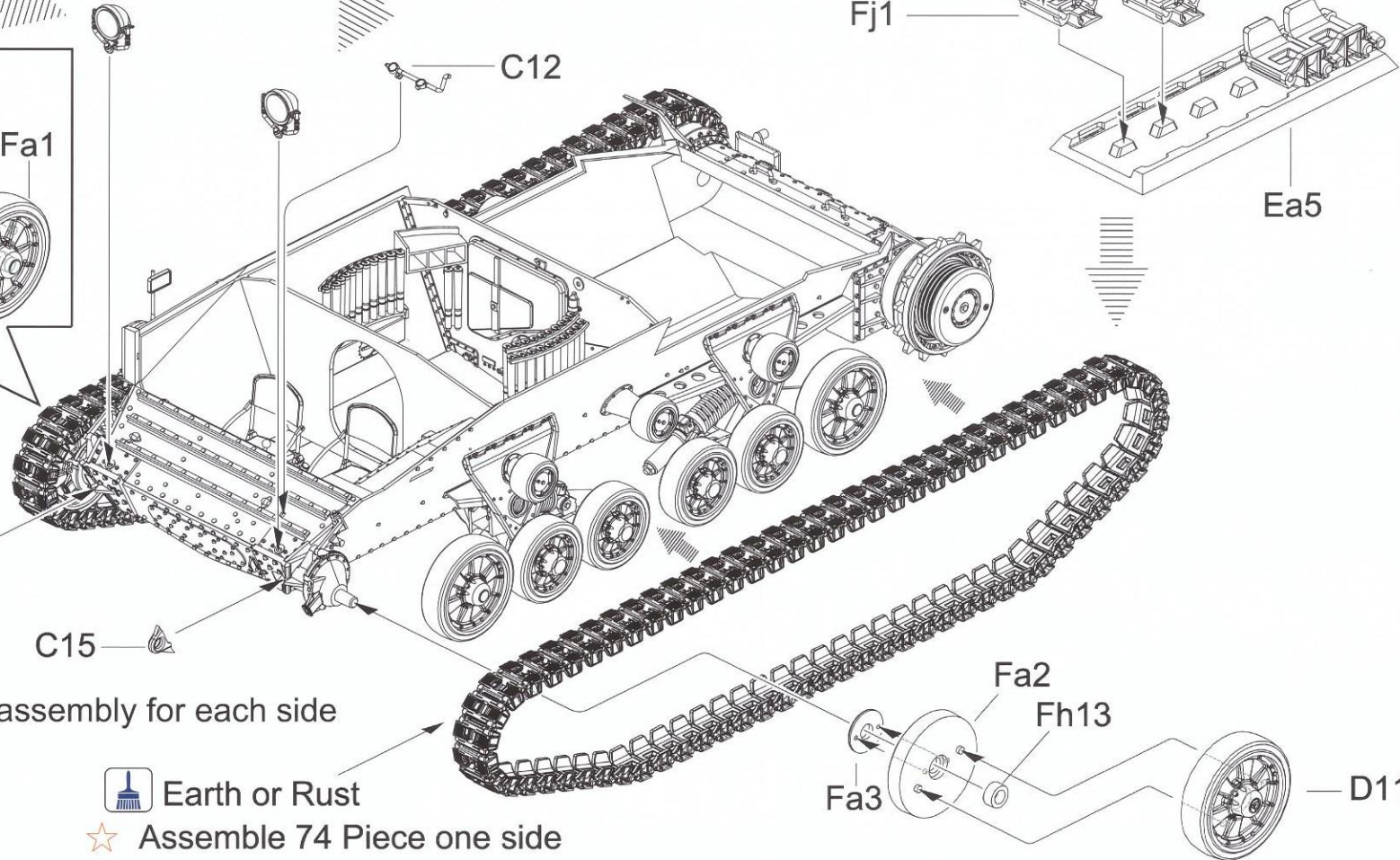
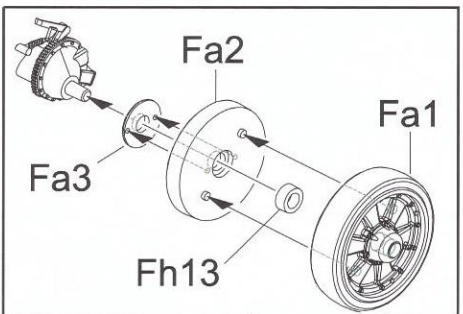
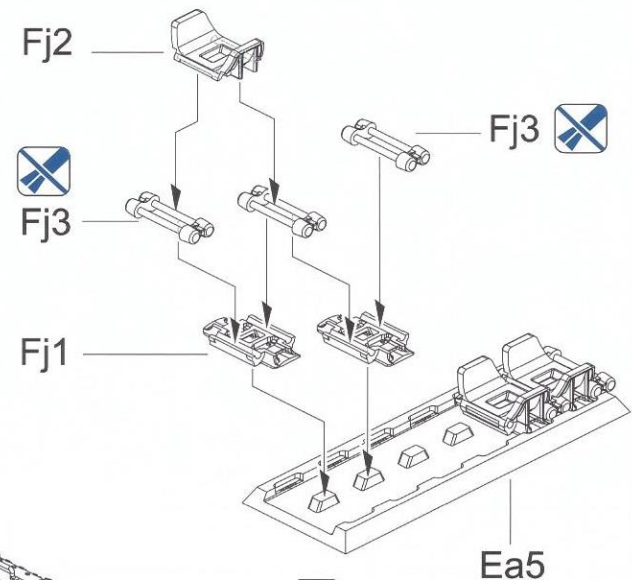
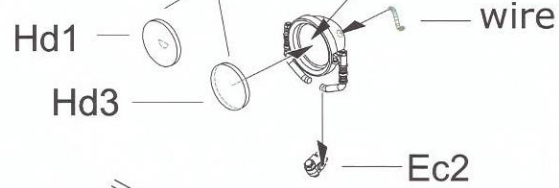
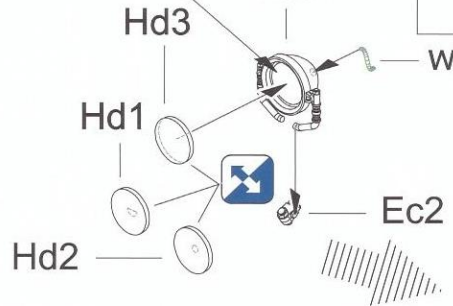

★ Track Links parts assembly for each side

Earth or Rust

★ Assemble 74 Piece one side

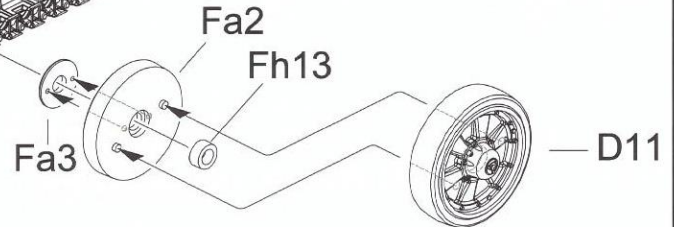

14

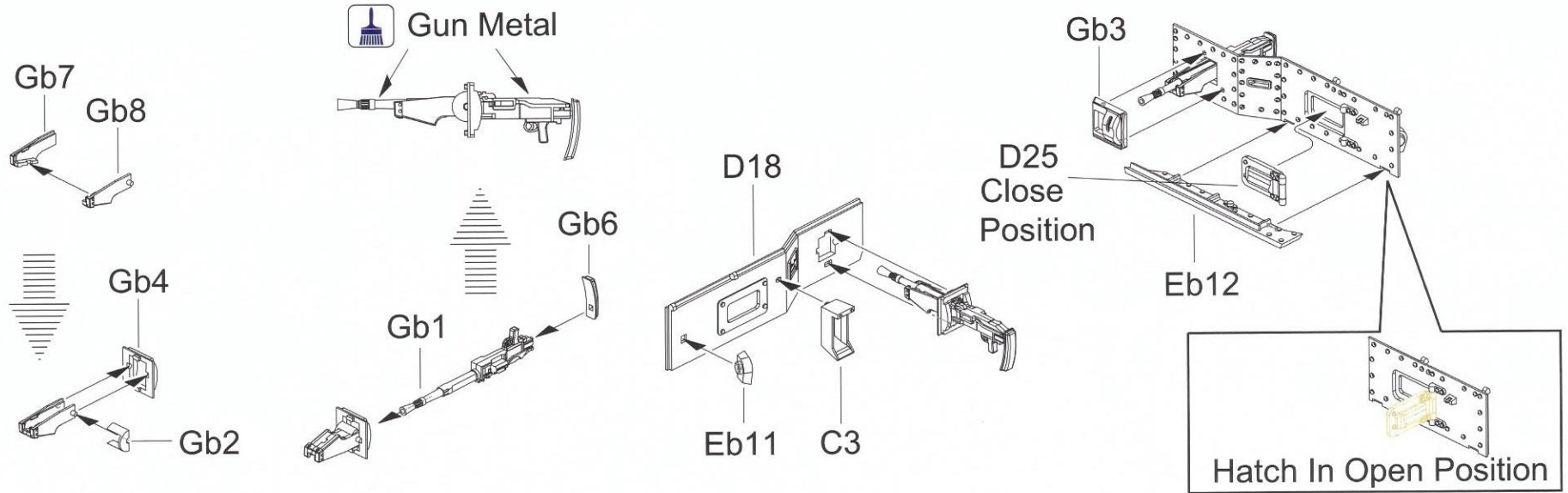

15

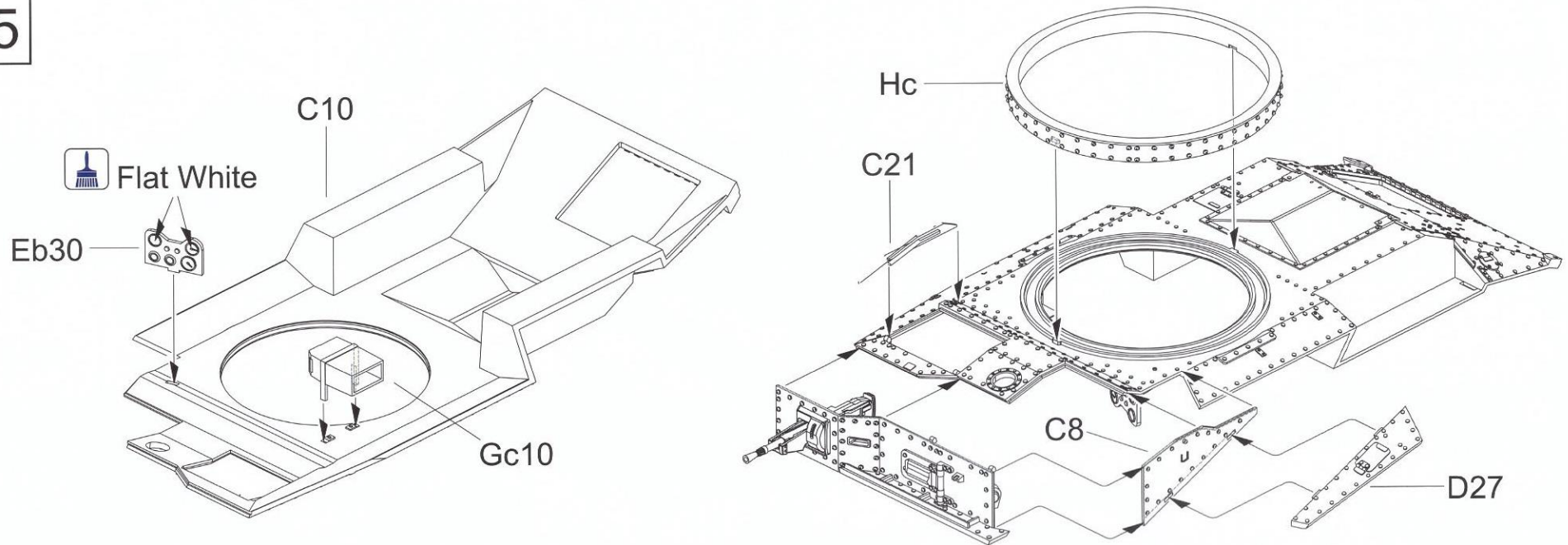

16

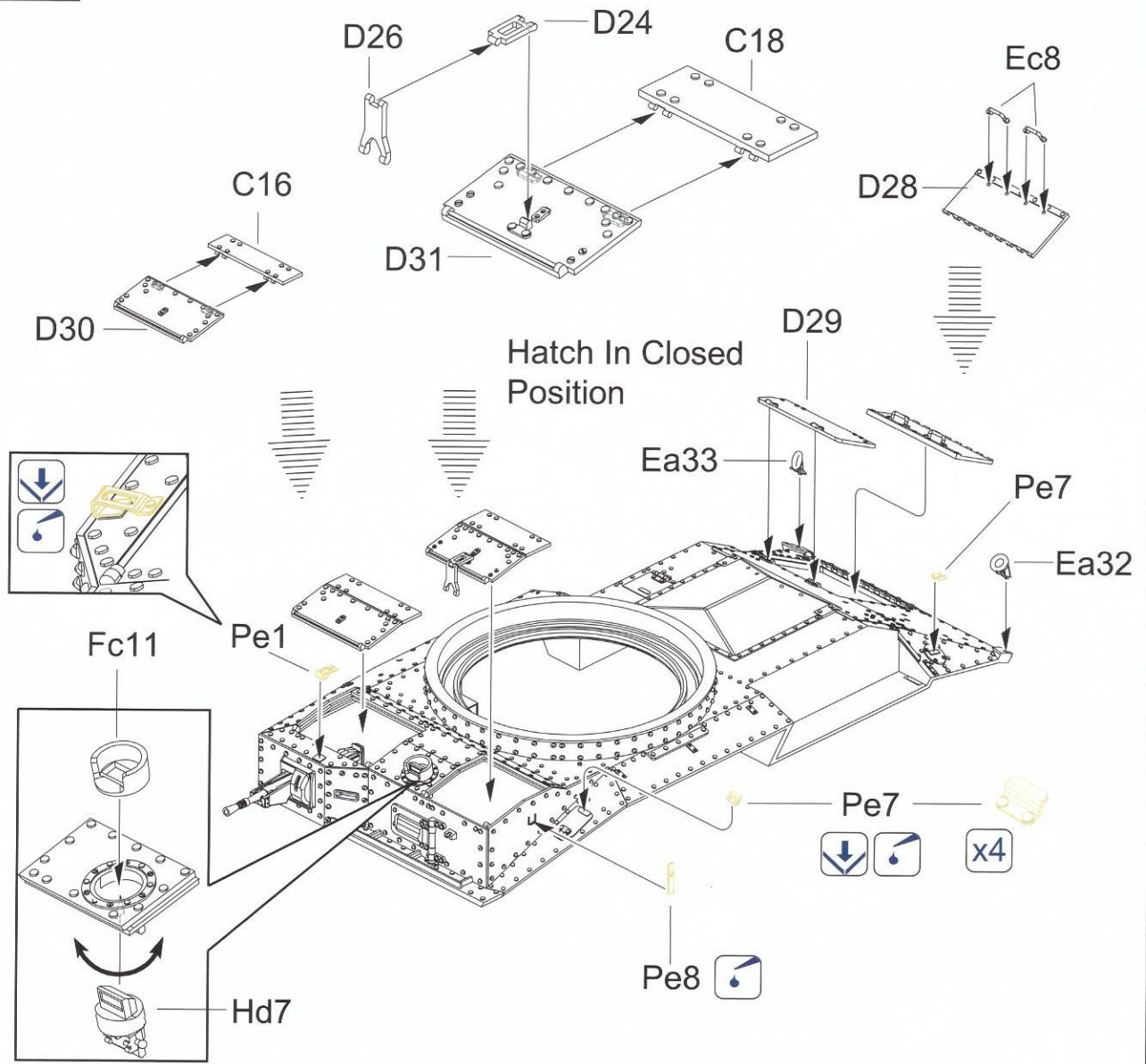

17

Step H

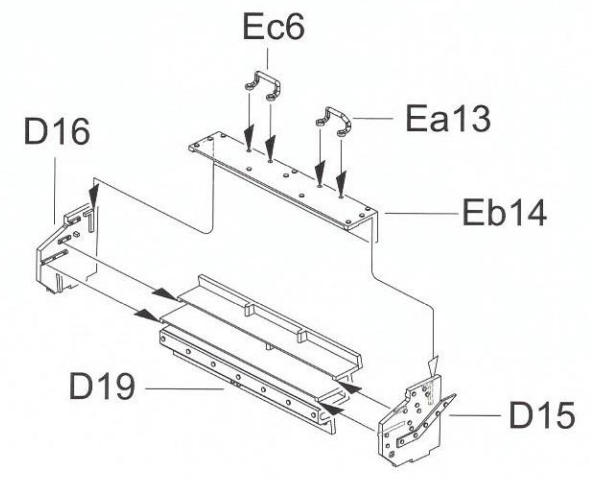

18

Step I

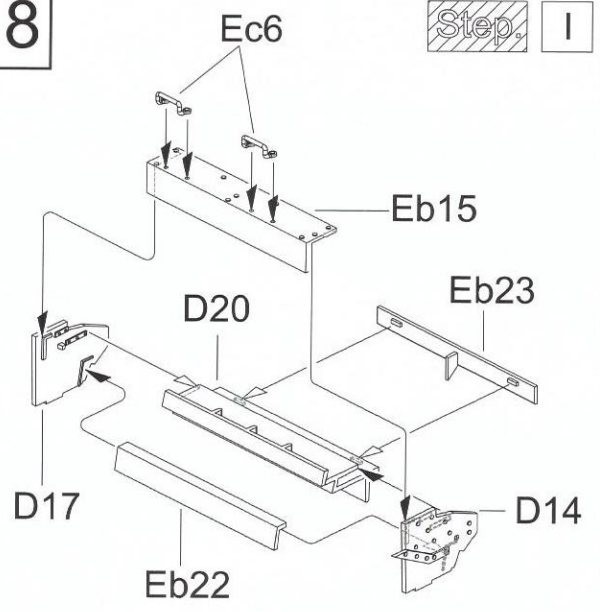

19

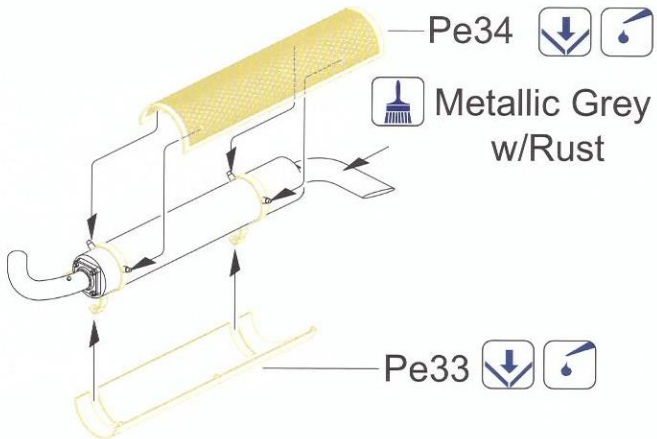
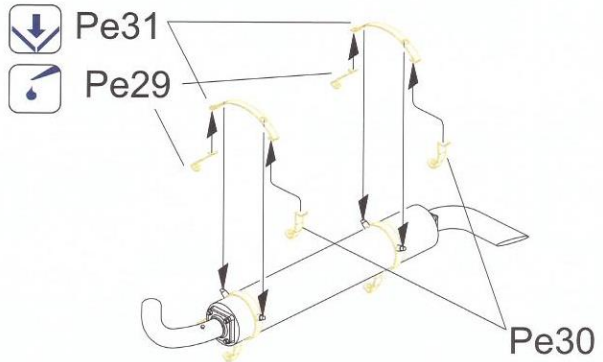
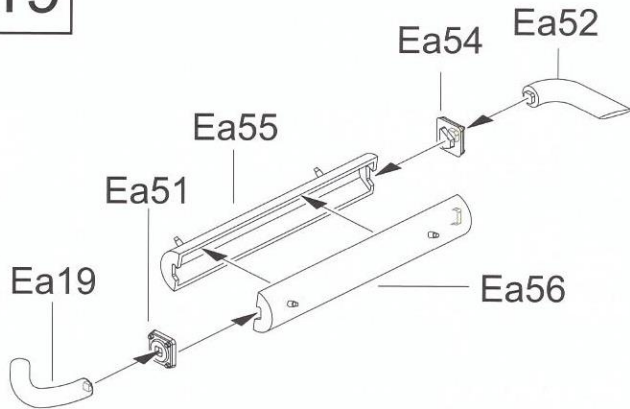

20

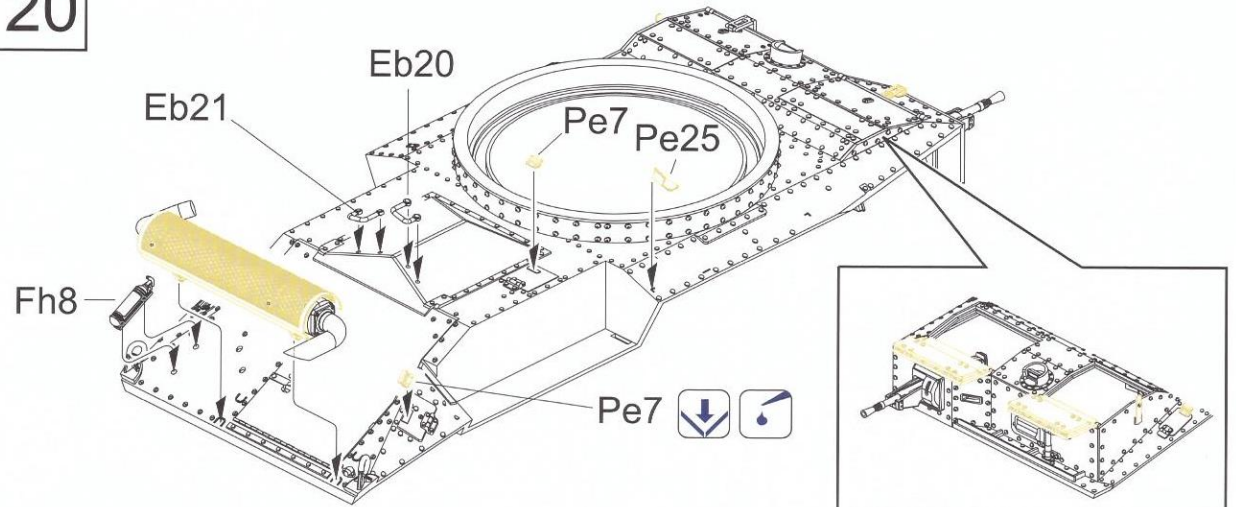

Hatch In Open Position

21

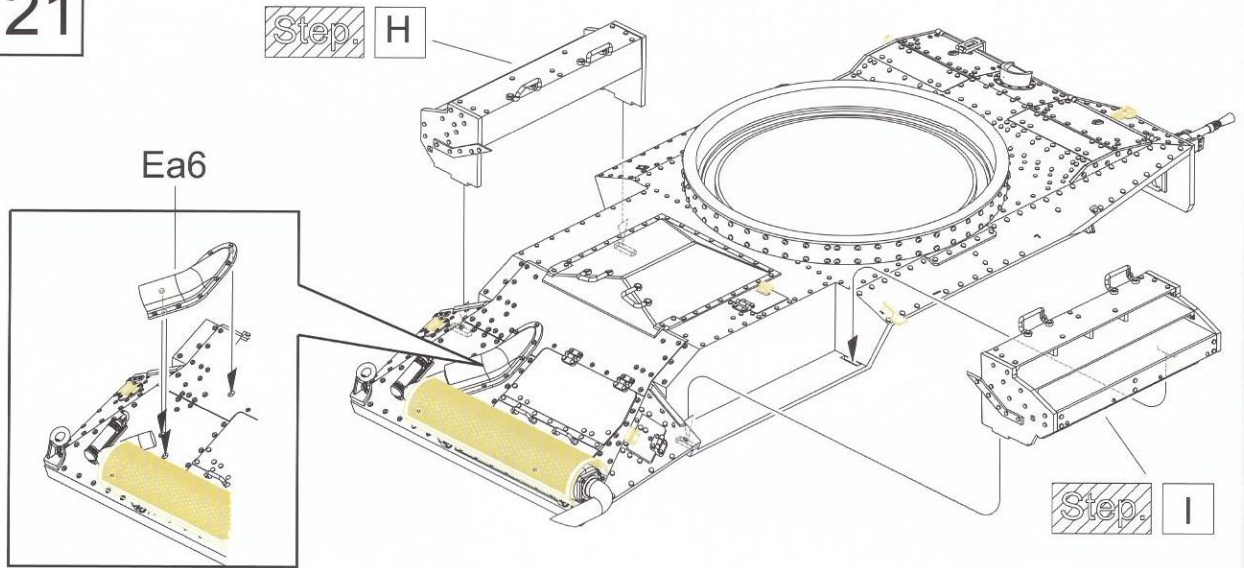

22

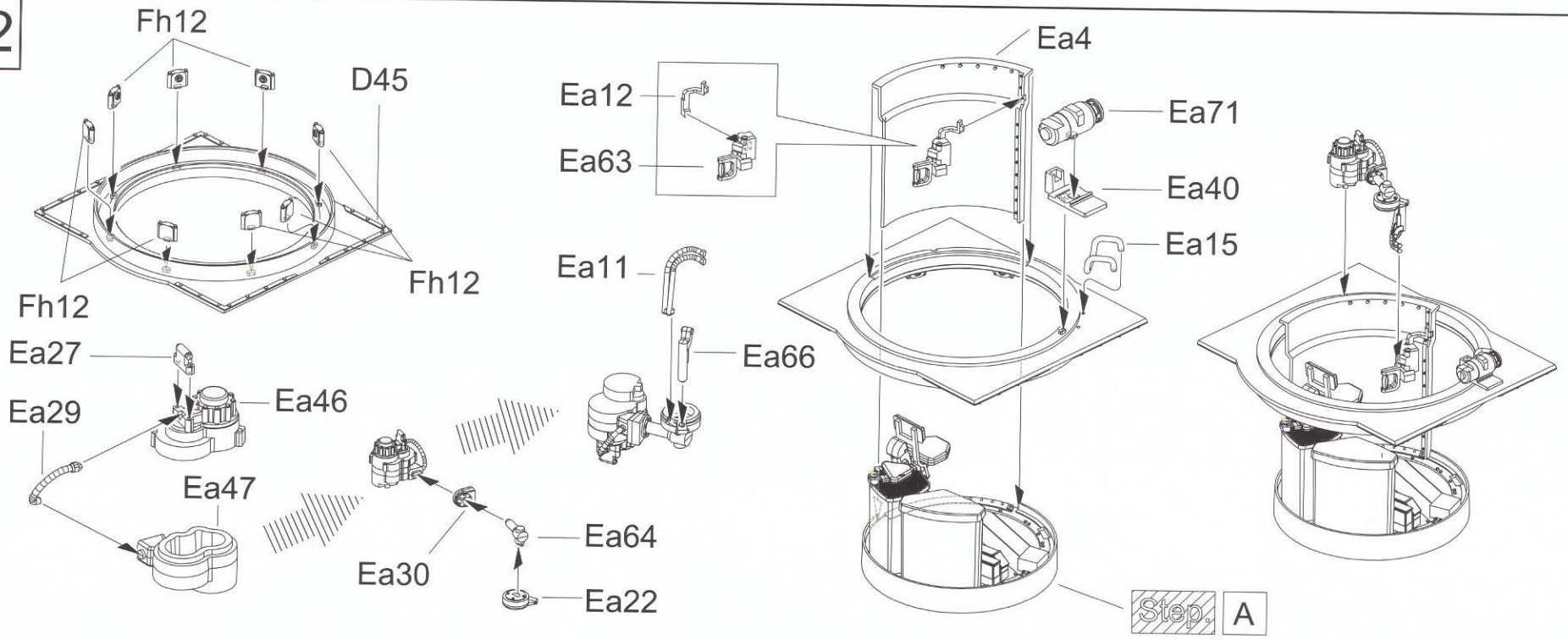

23

Assembly For Desert Version

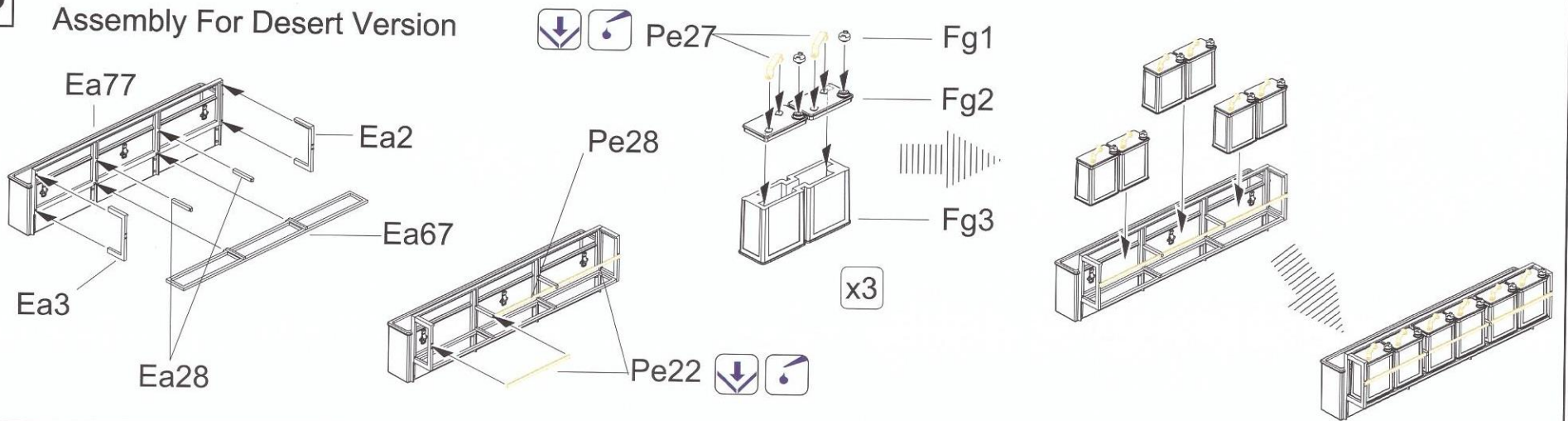

24

Assembly For Standard Version

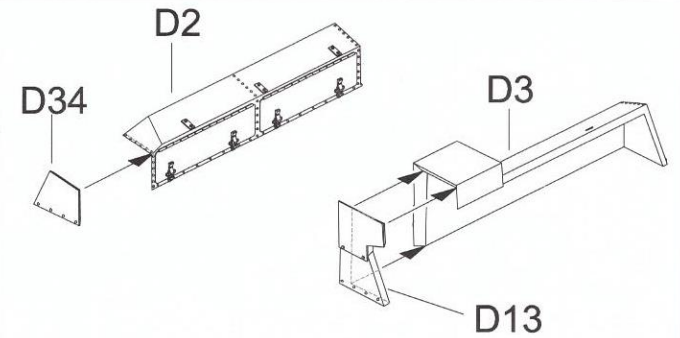
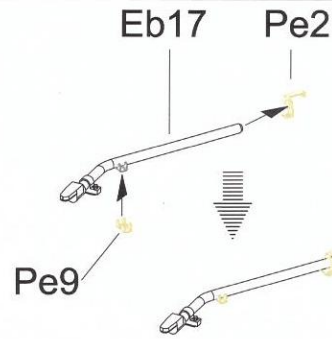
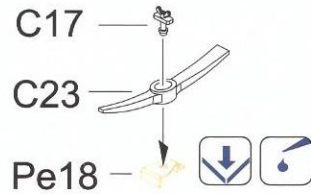
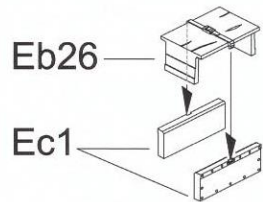

25

Step J

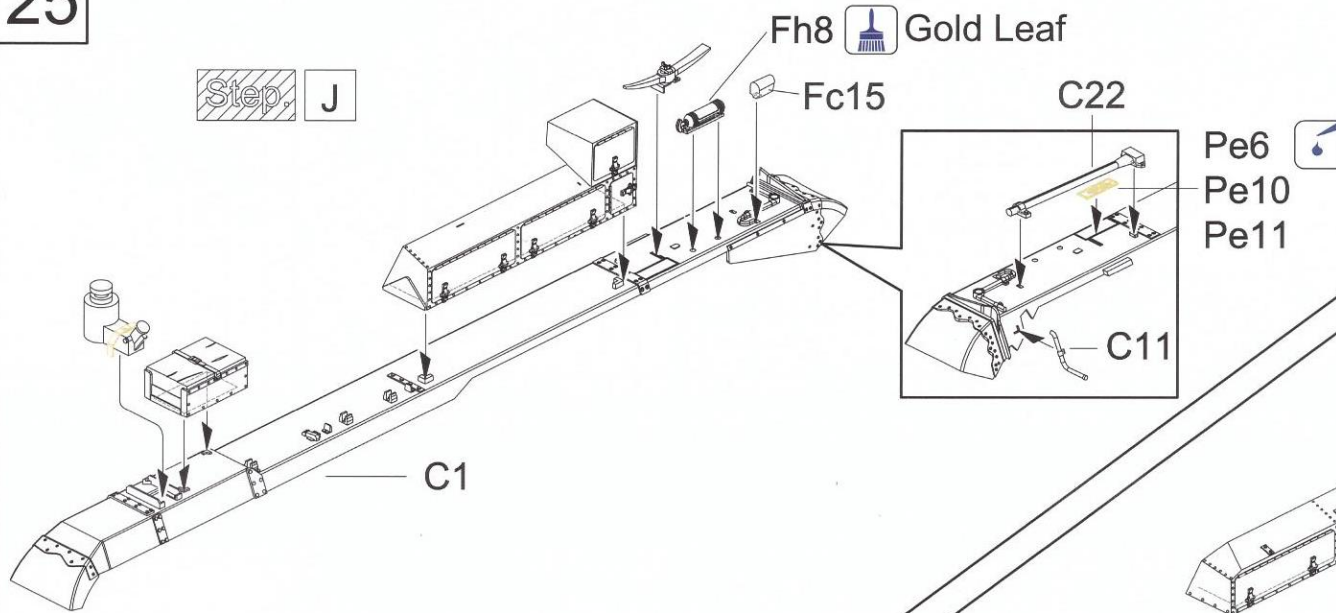

Right fender

Step K

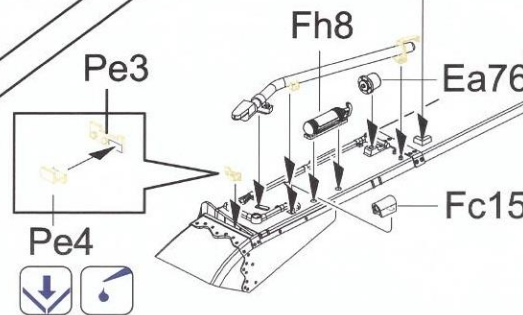

Left fender

26

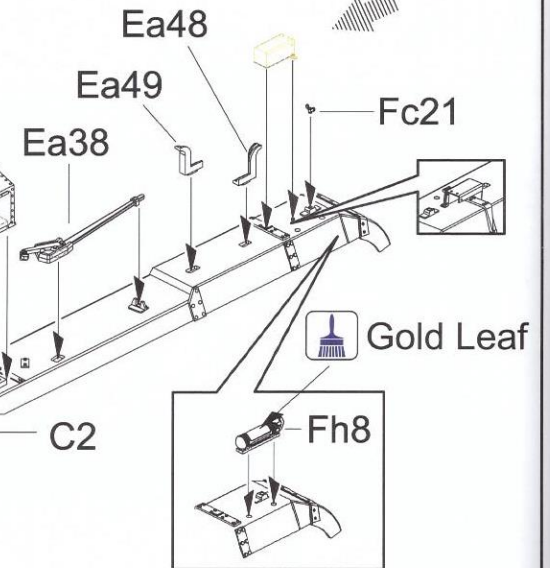
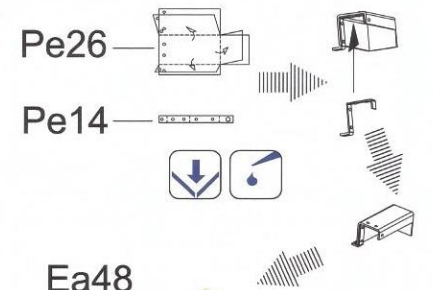



27

Fuel Tank Assembly

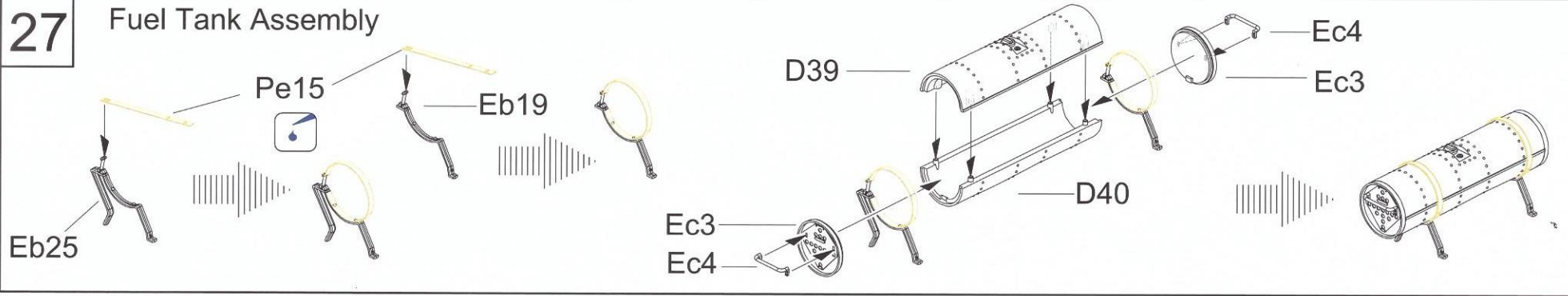

28

Assembly For Desert Version

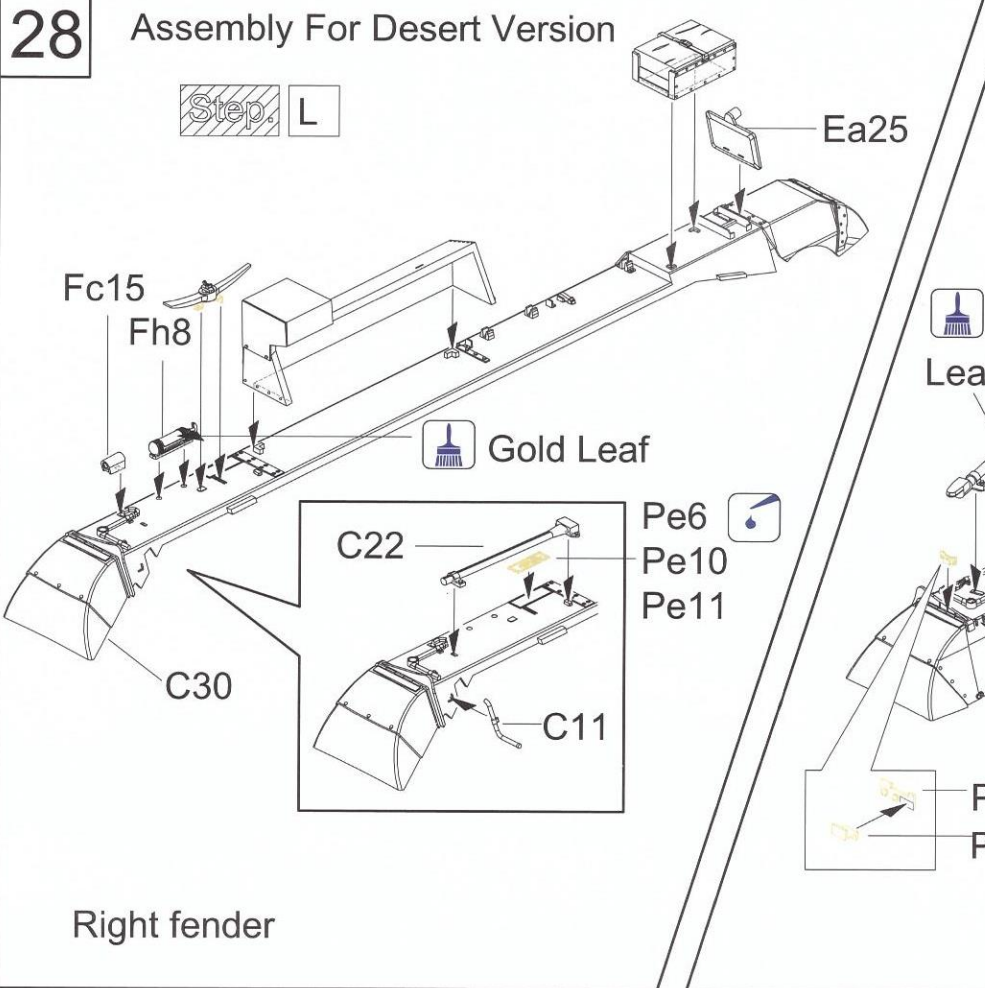

Right fender

29

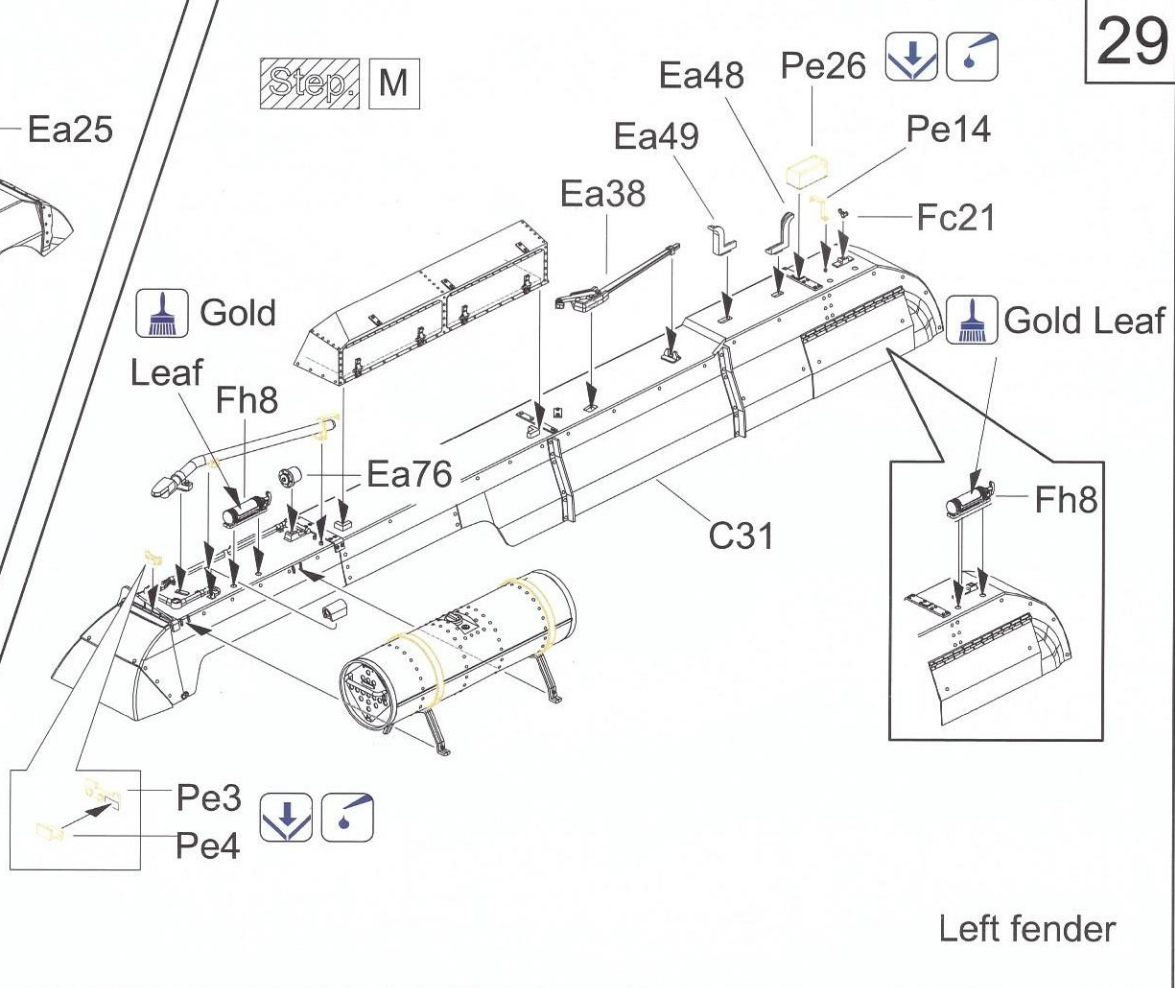

Left fender

30

Optional

Standard Version

Step. J

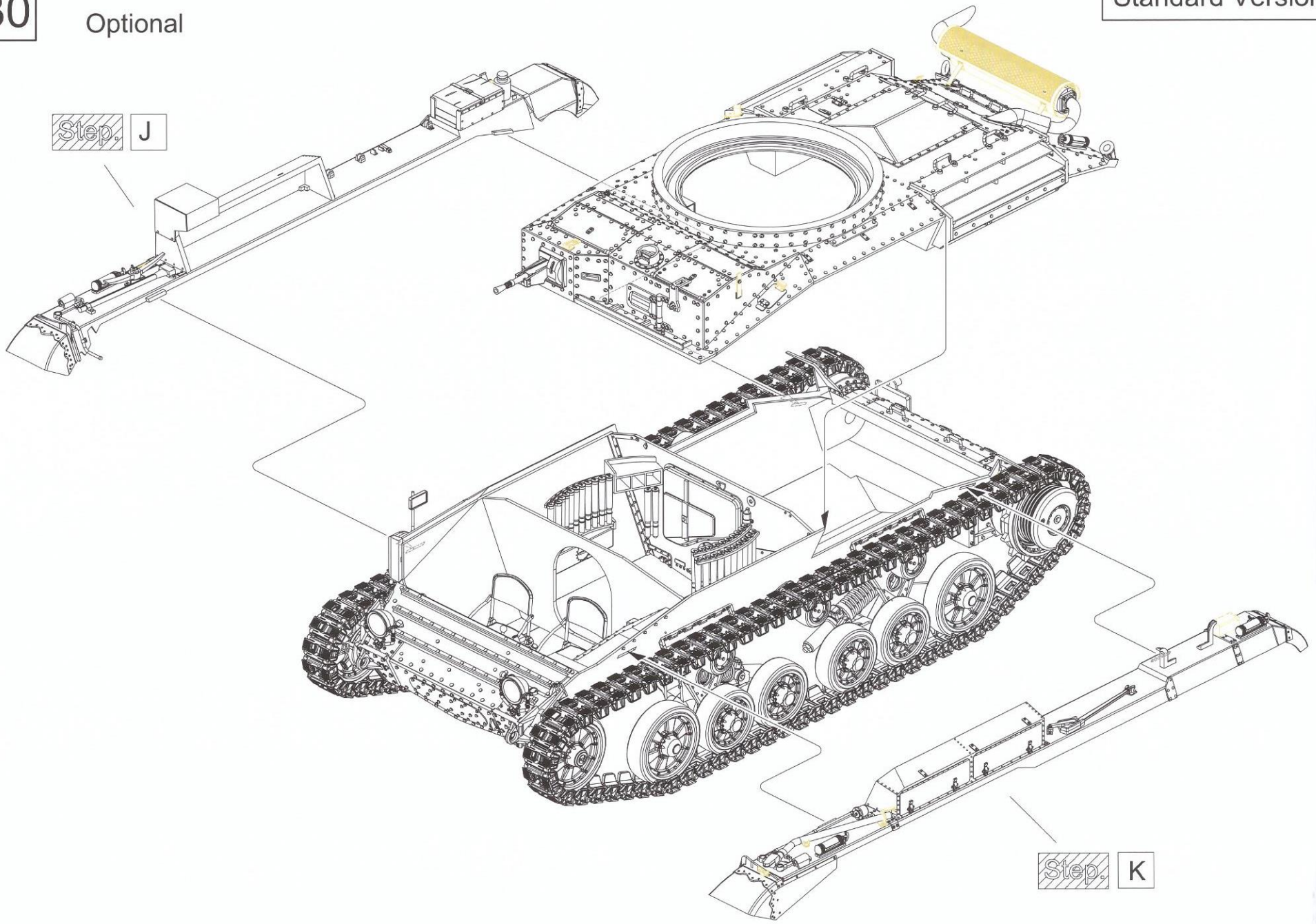

Step. K

31

Optional

Desert Version

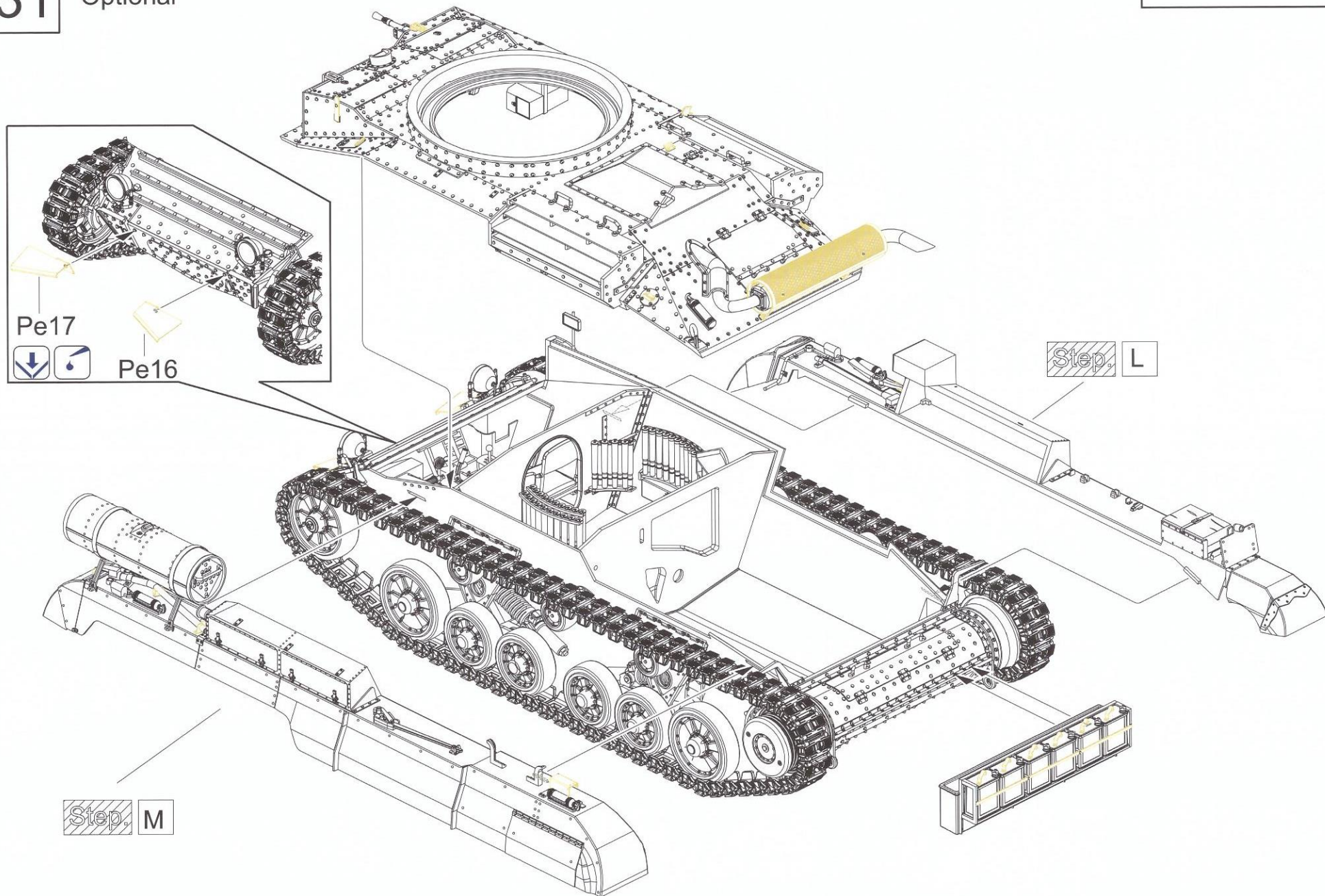

32

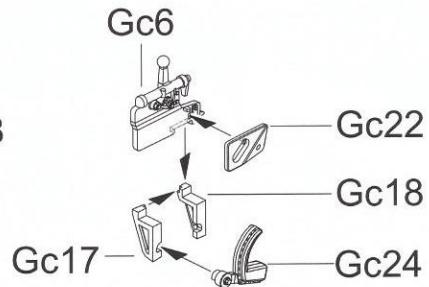
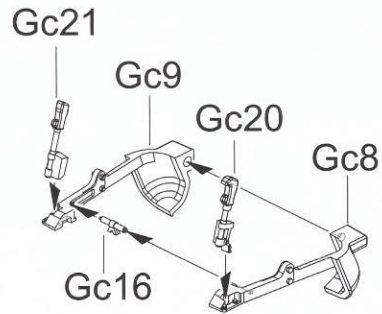
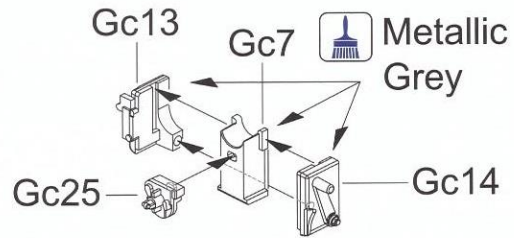
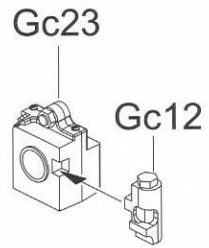

33

Interior Colour Silver

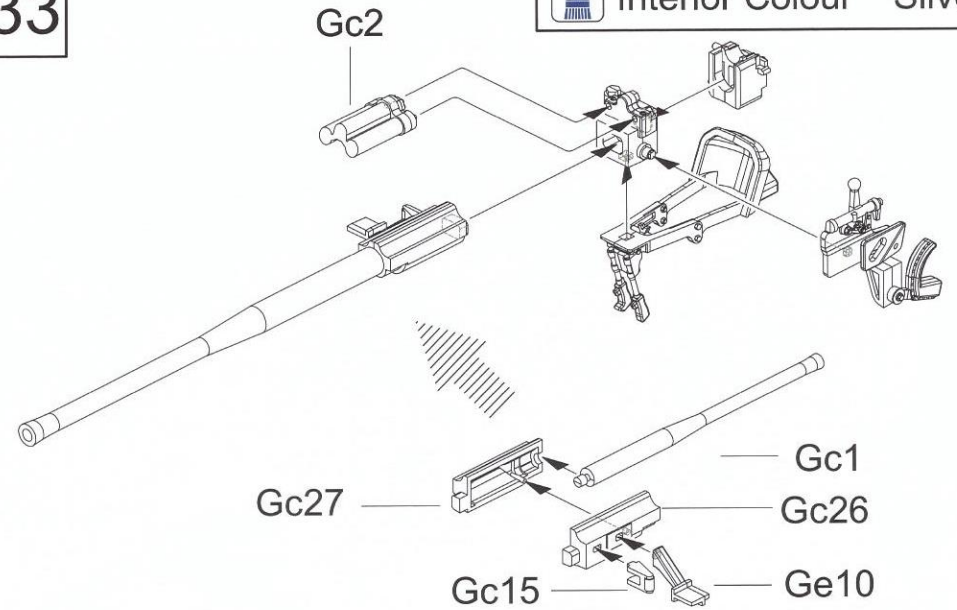

34

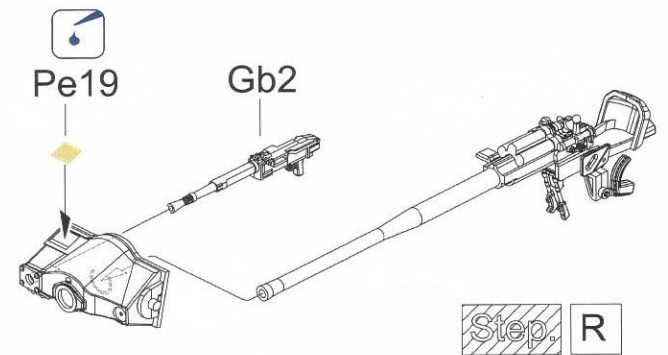
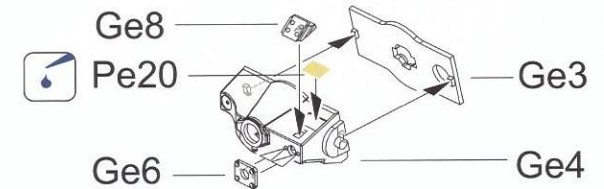
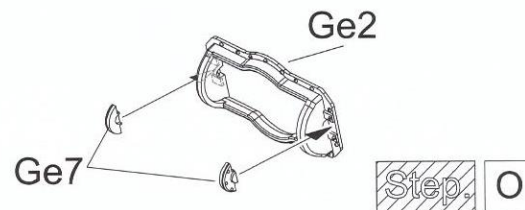
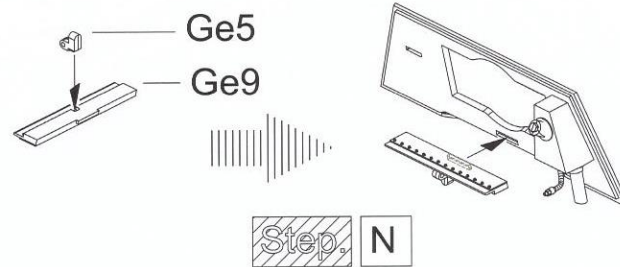
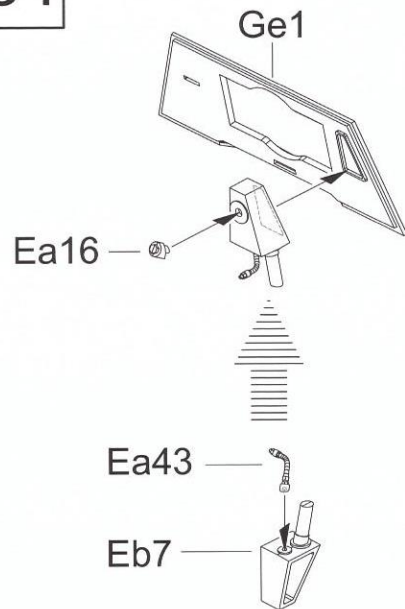

35

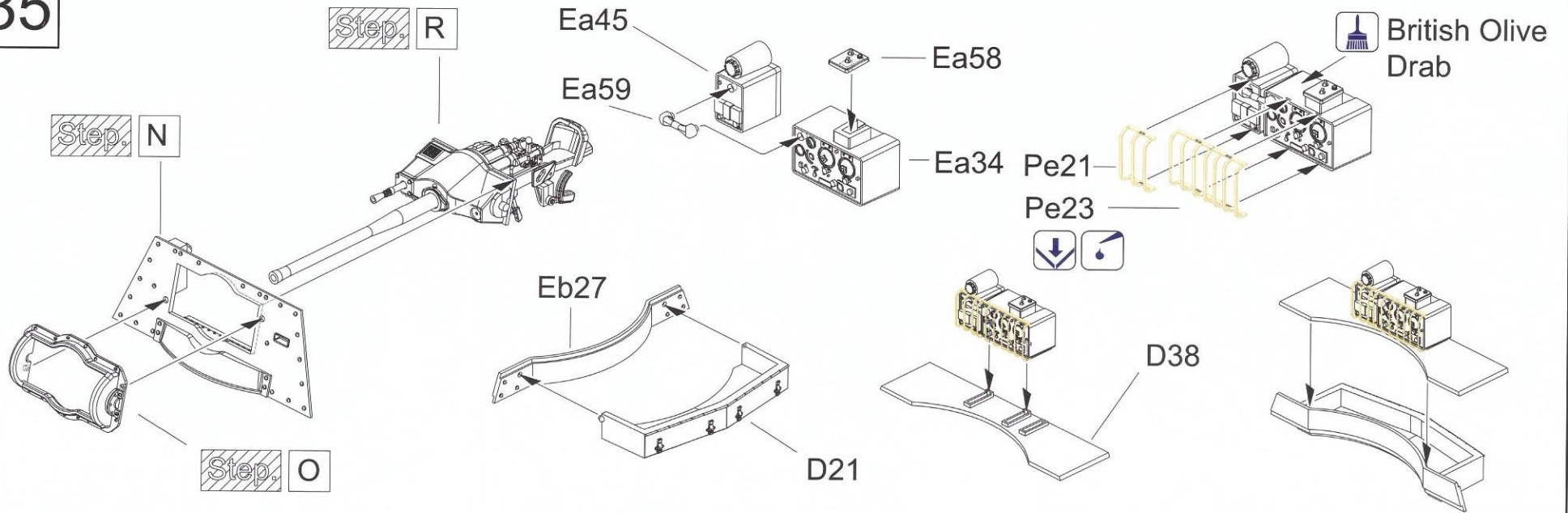

36

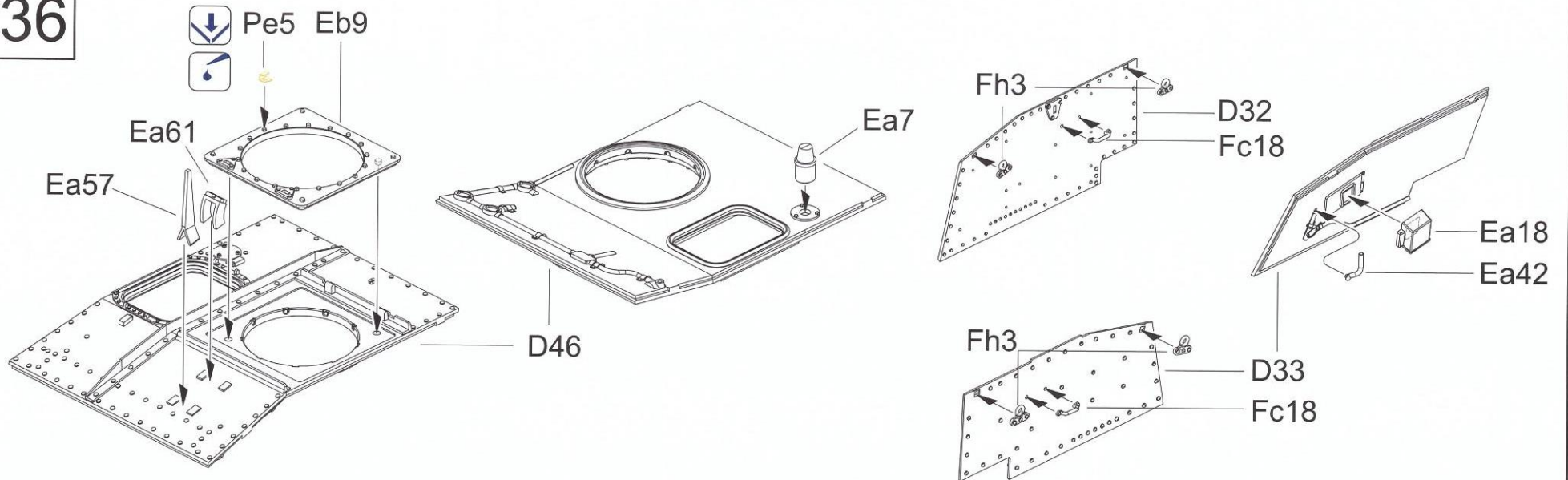

37

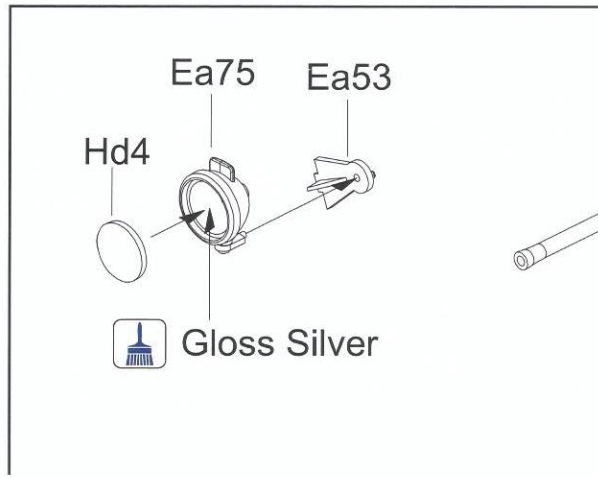
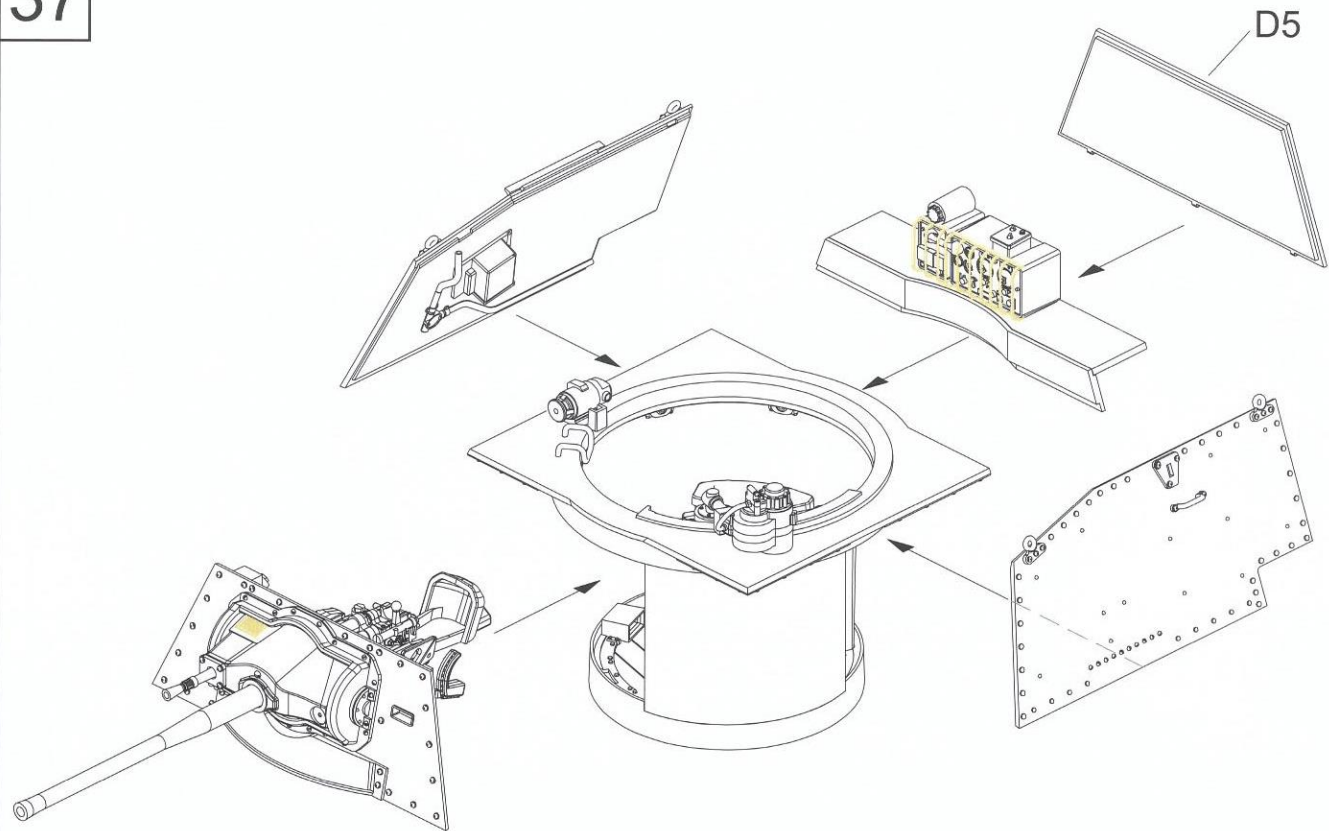

38

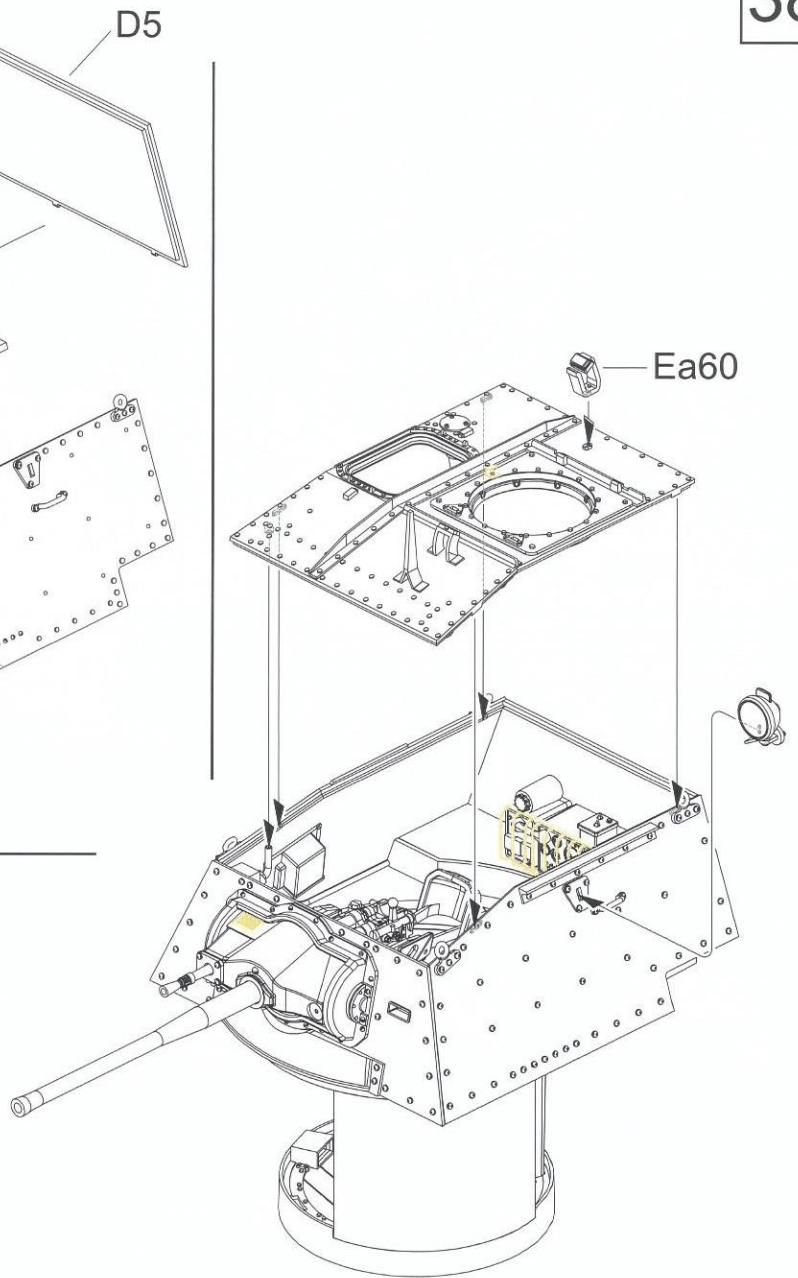

39

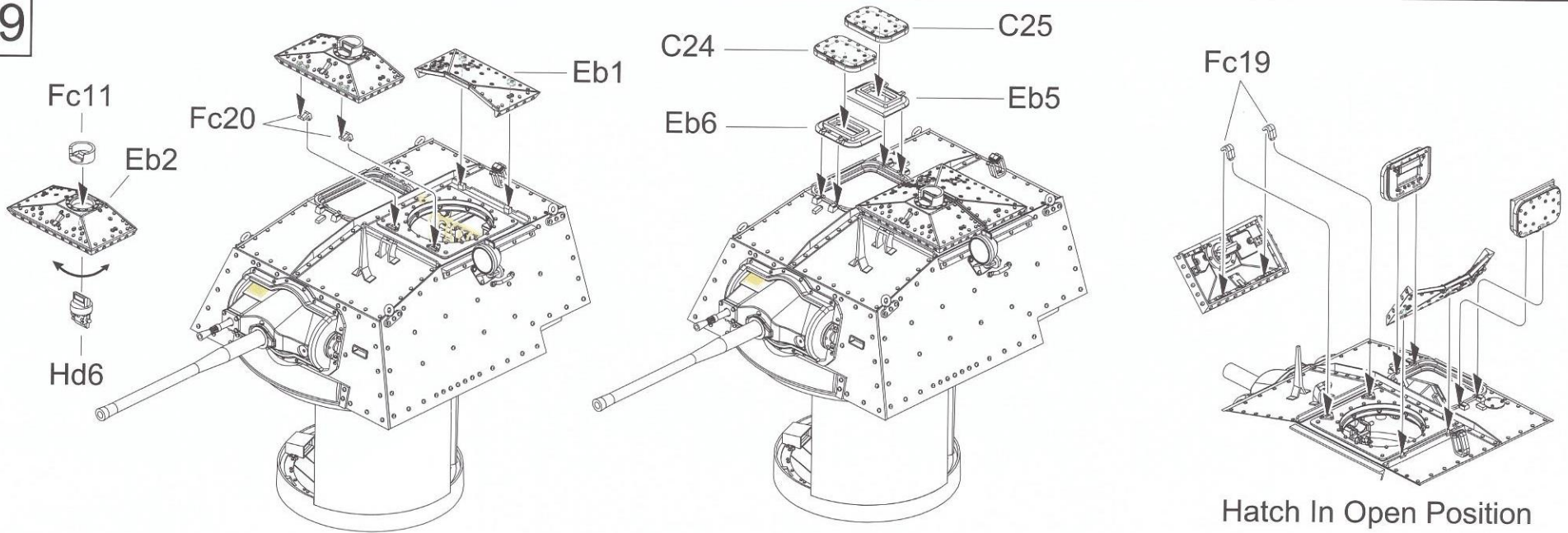

Hatch In Open Position

40

Spare Tire For Desert Version Only

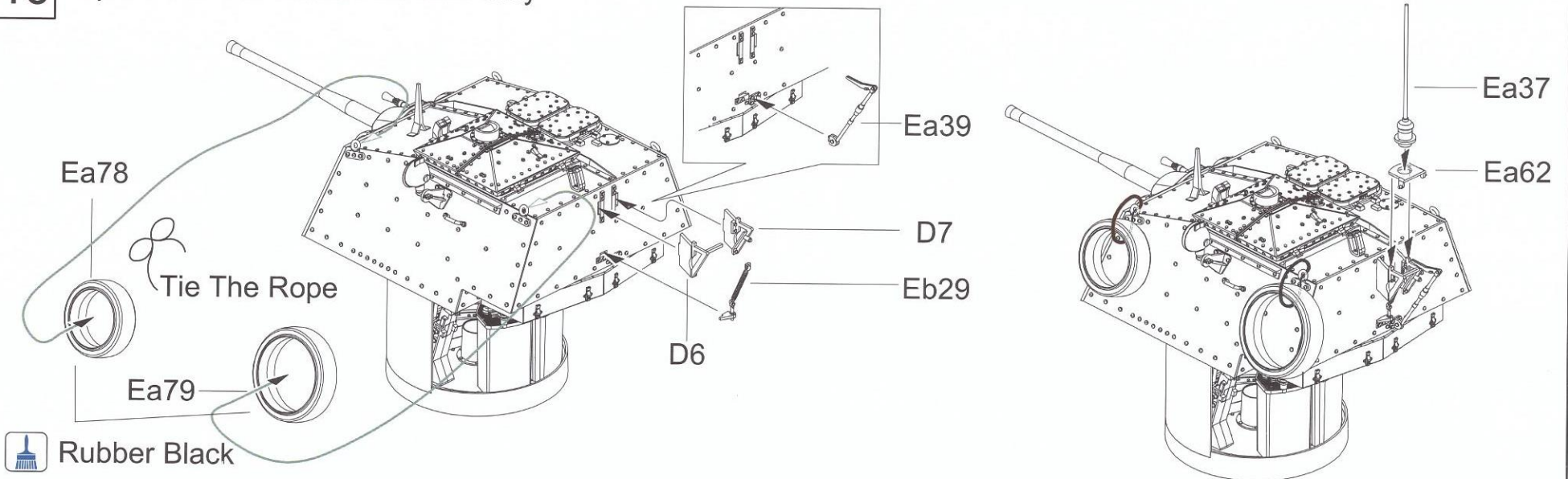

Rubber Black

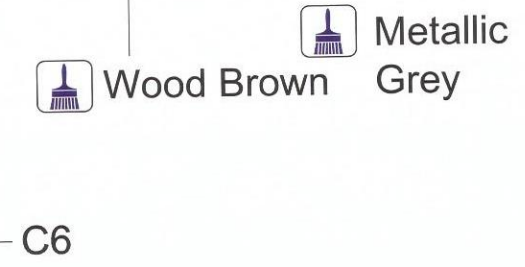
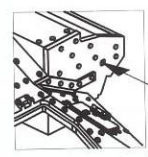
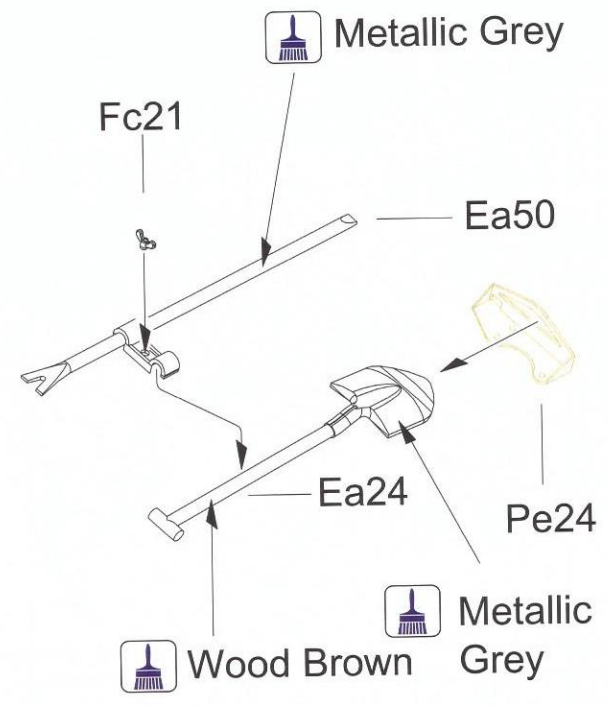
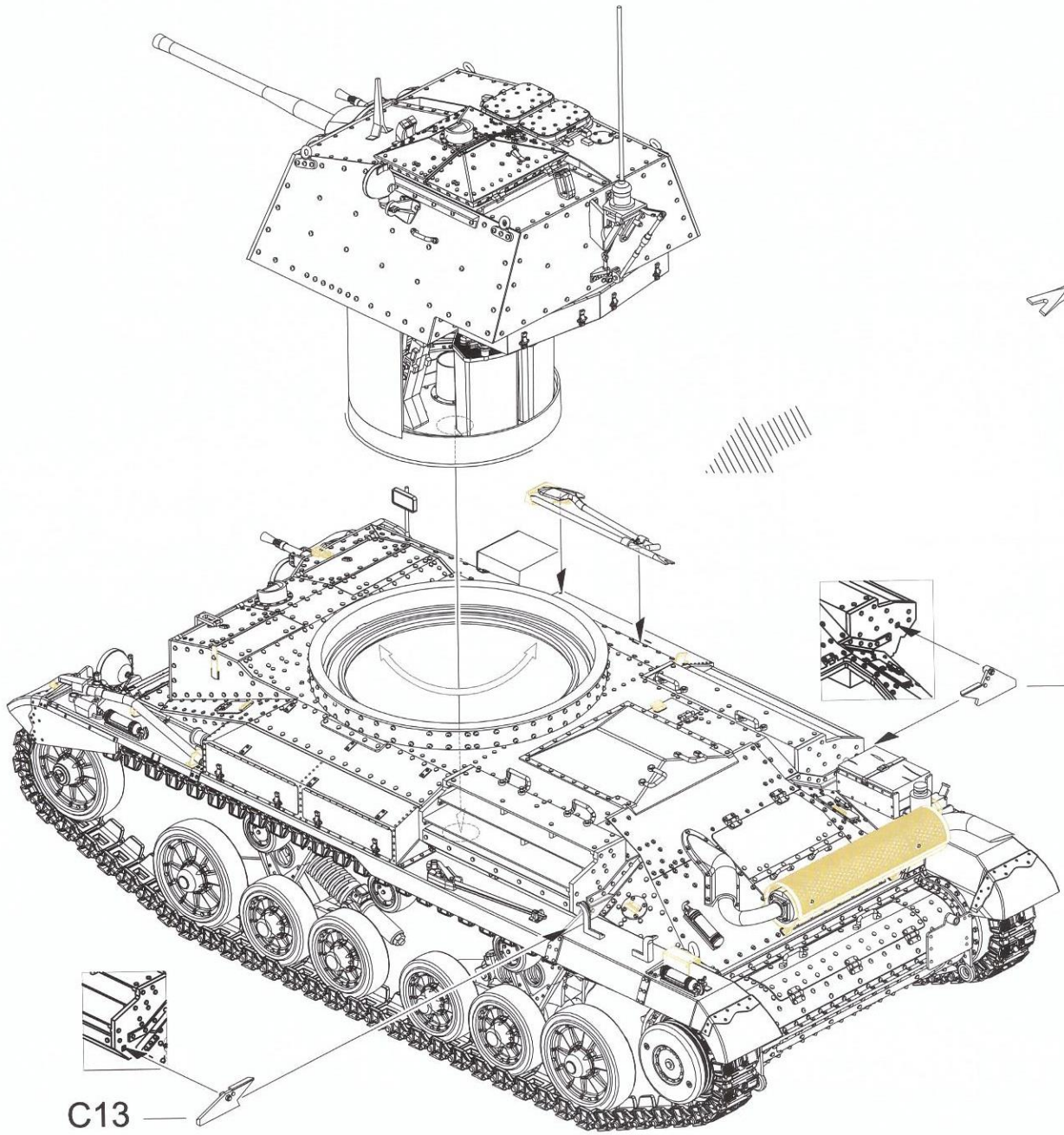



42

Standard Version

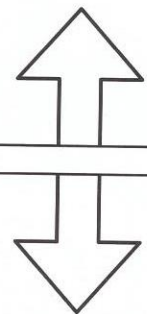
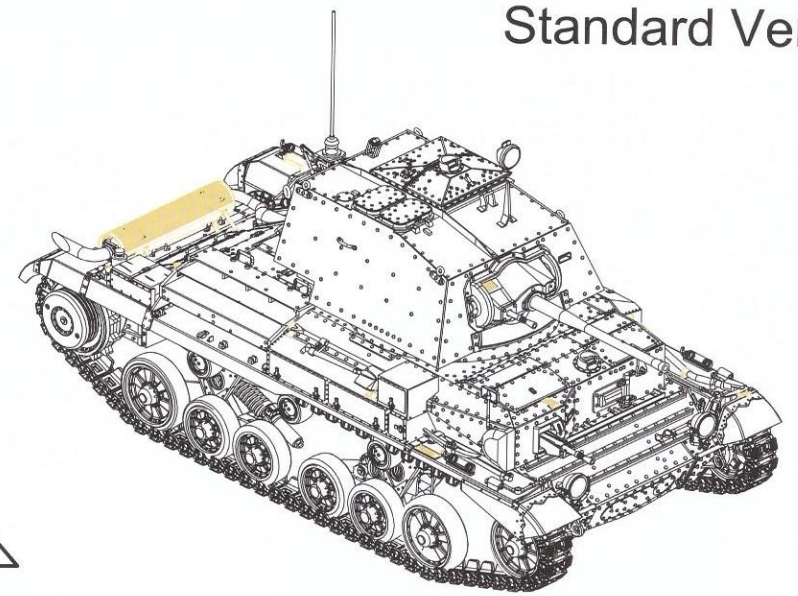
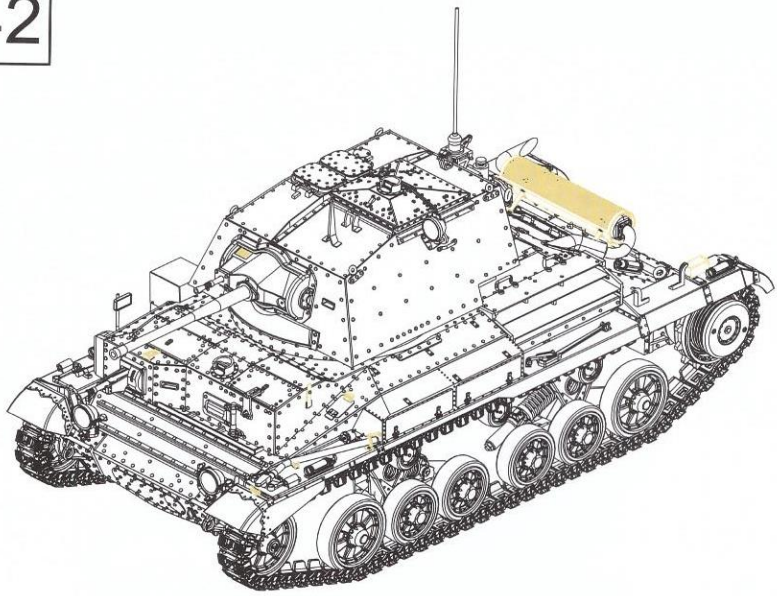

Desert Version

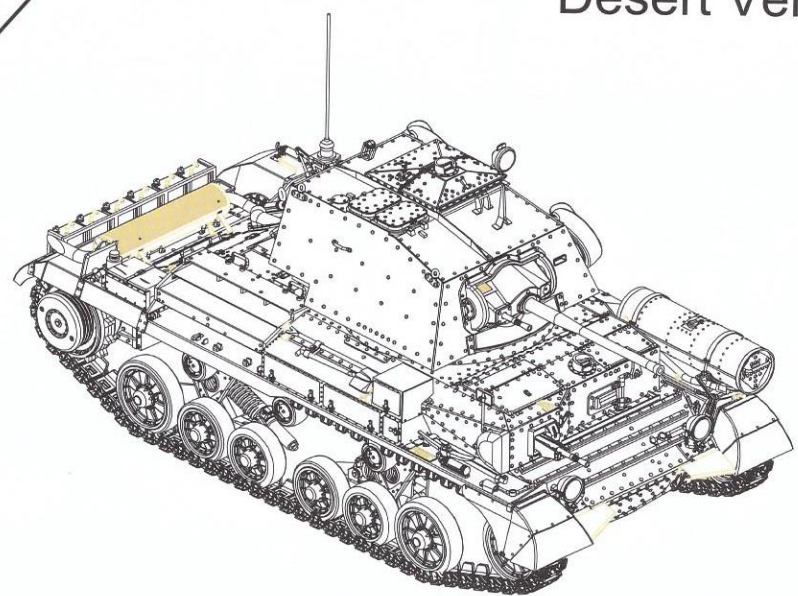
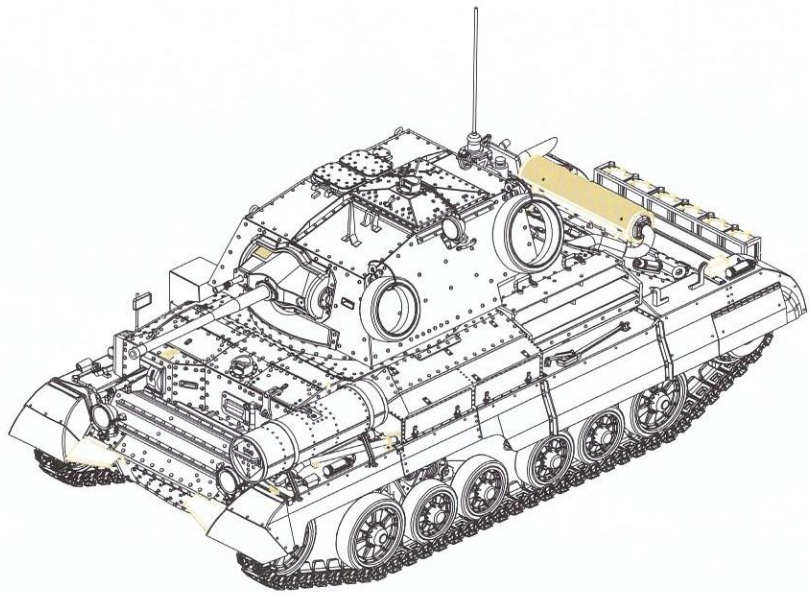

Option 1: C-Squadron, 2<sup>nd</sup> Royal Tank Regiment, 1<sup>st</sup> Armoured Division, UK 1940.

Khaki Green No.3  
(Basic Colour)(G3)

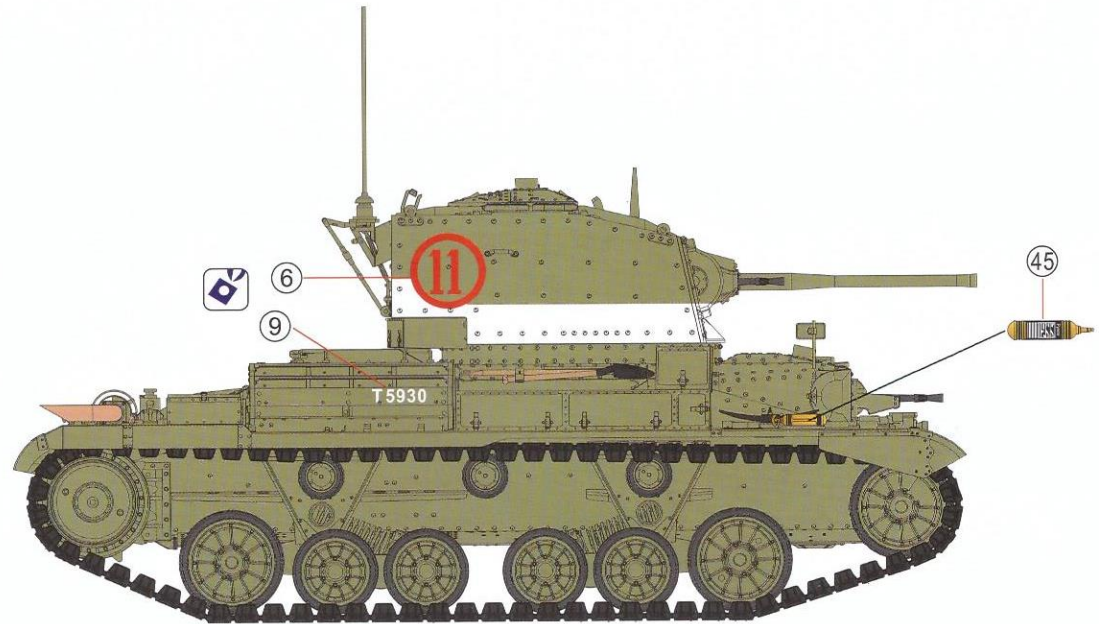
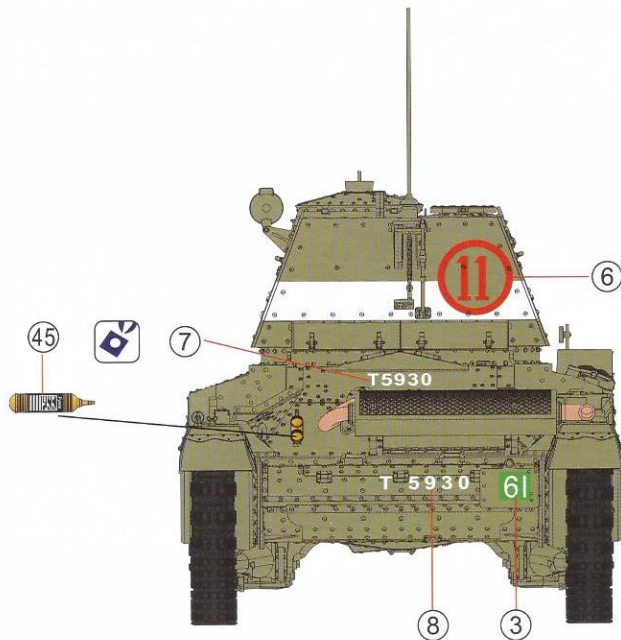
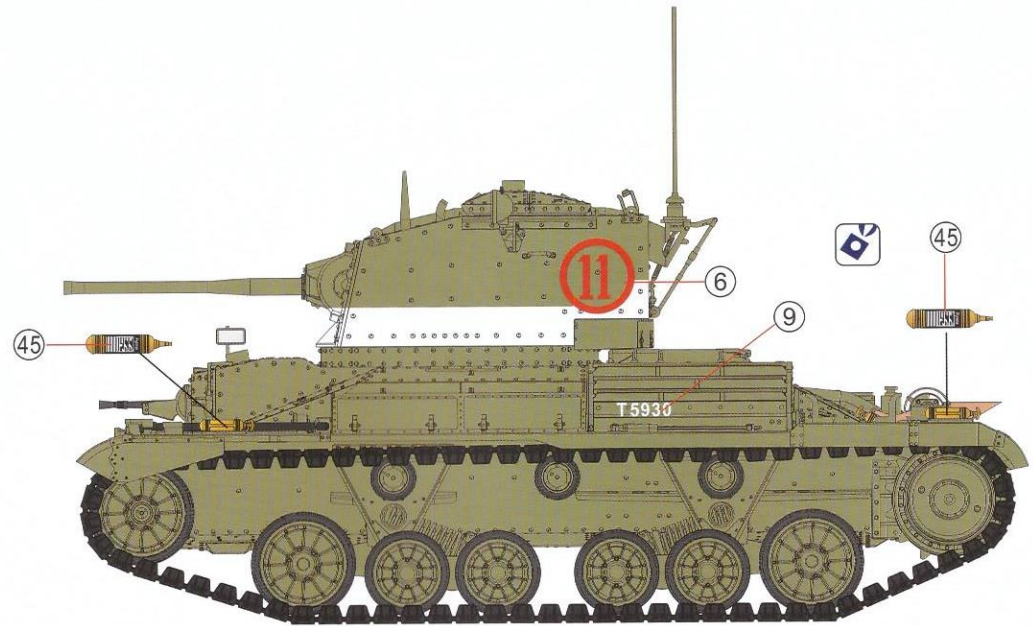
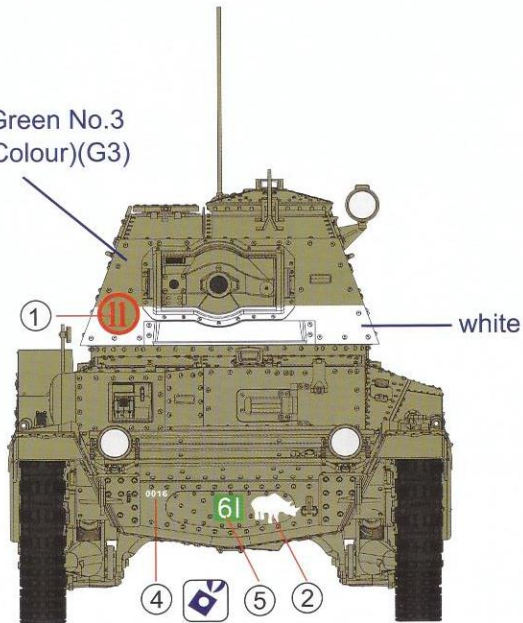

# Option 2: B-Squadron, 3<sup>rd</sup> Royal Tank Regiment, 2<sup>nd</sup> Armoured Division, Greece 1941.

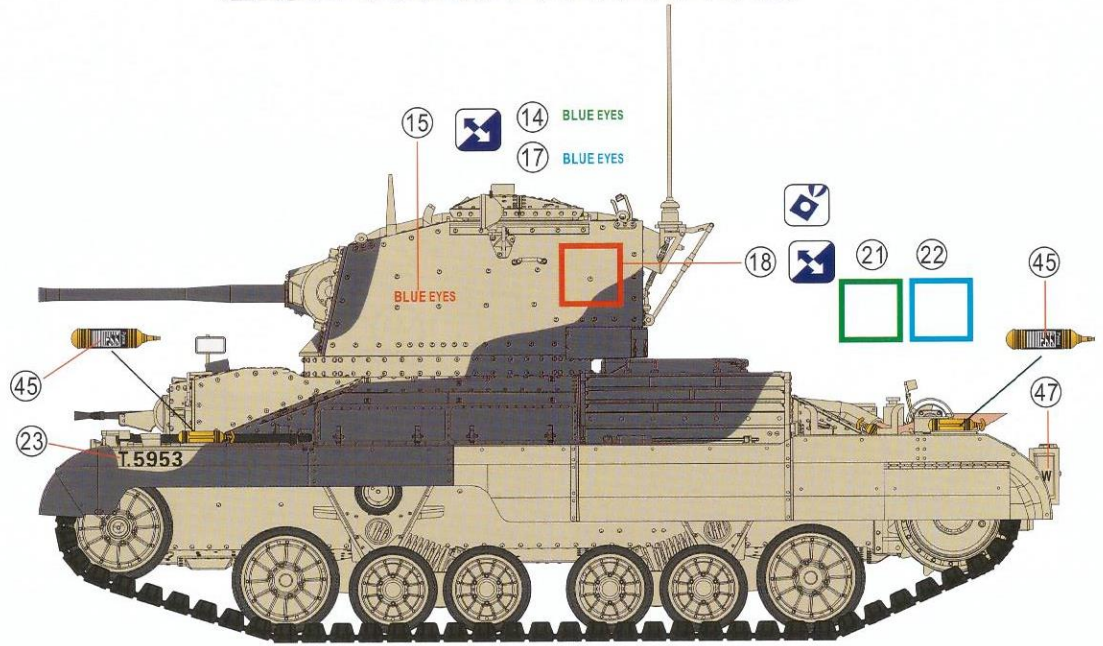
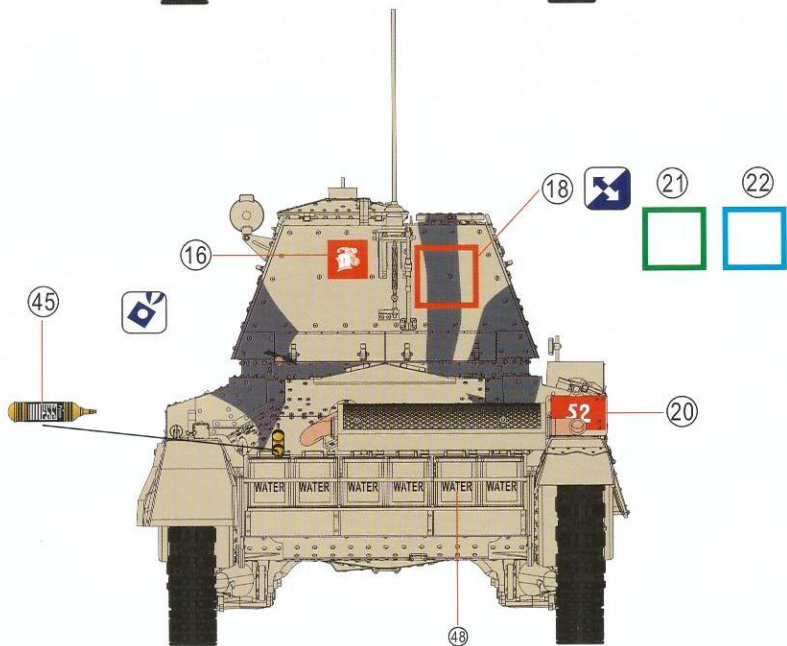
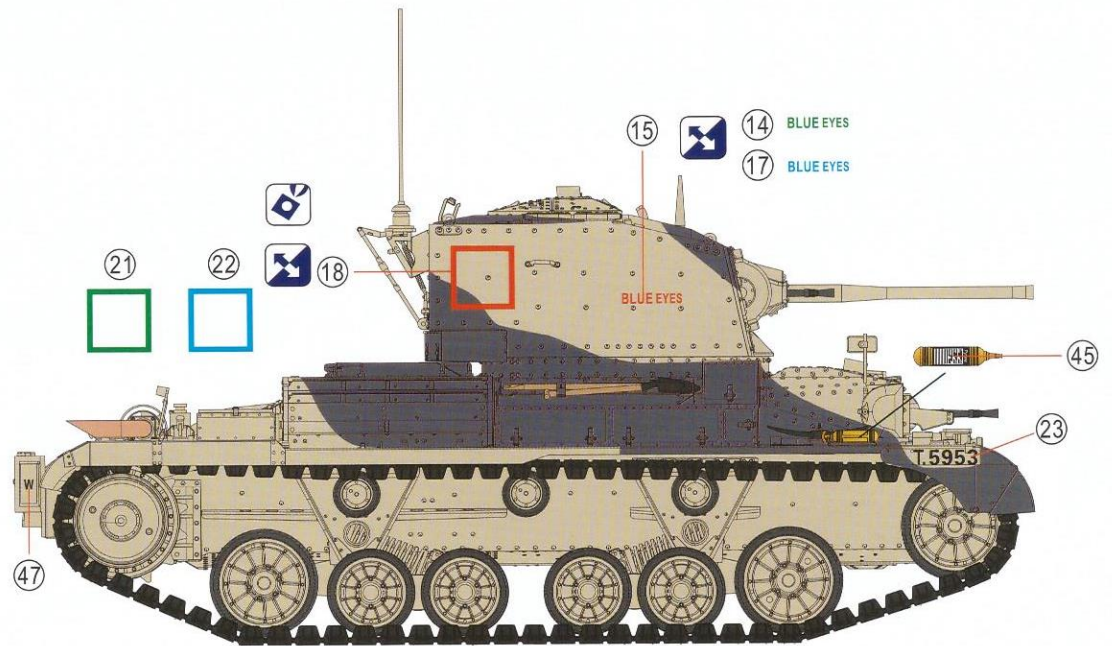
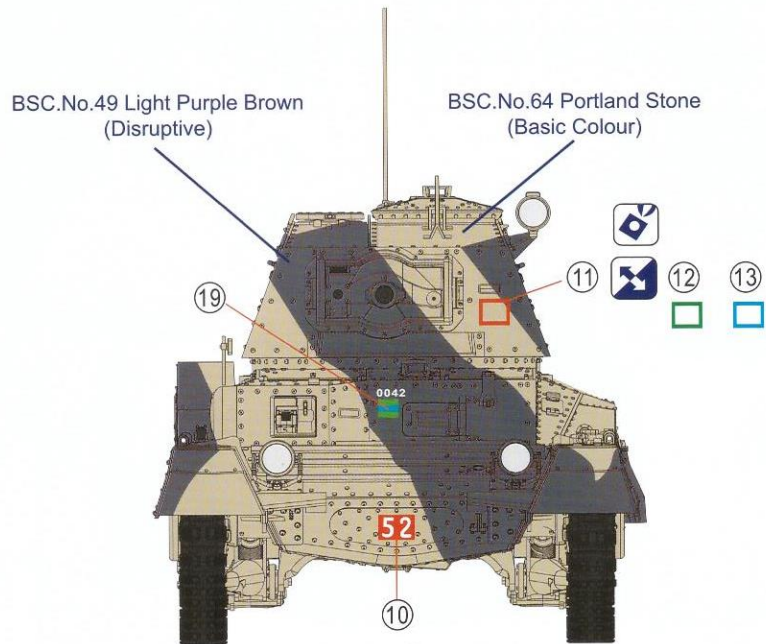

# Option 3: C-Squadron, 3<sup>rd</sup> Royal Tank Regiment, 2<sup>nd</sup> Armoured Division, Greece 1941.

BSC.No.49 Light Purple Brown  
(Disruptive)

BSC.No.64 Portland Stone  
(Basic Colour)

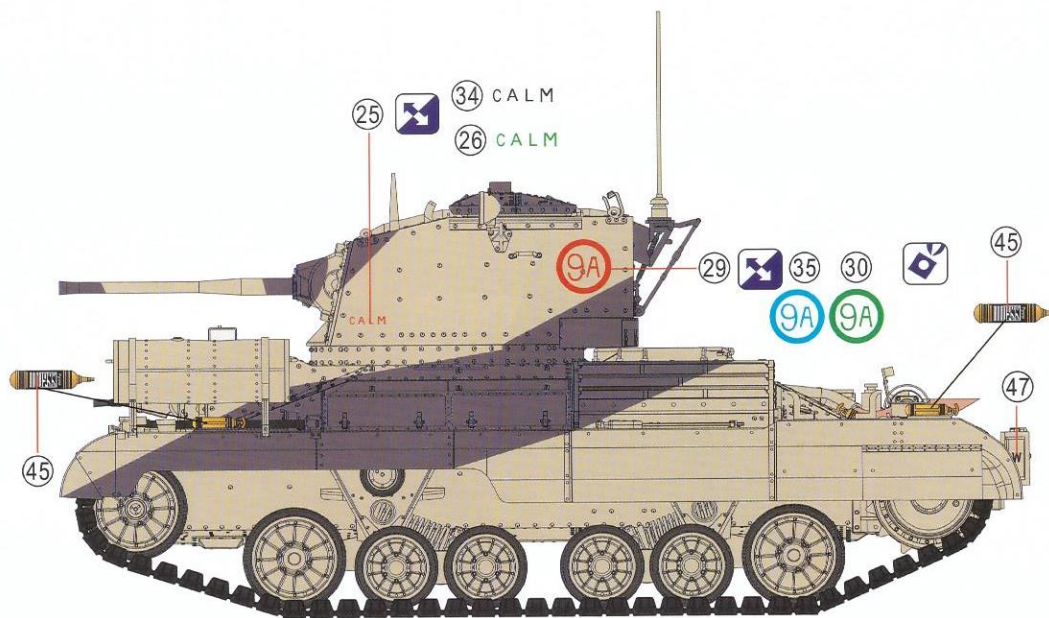
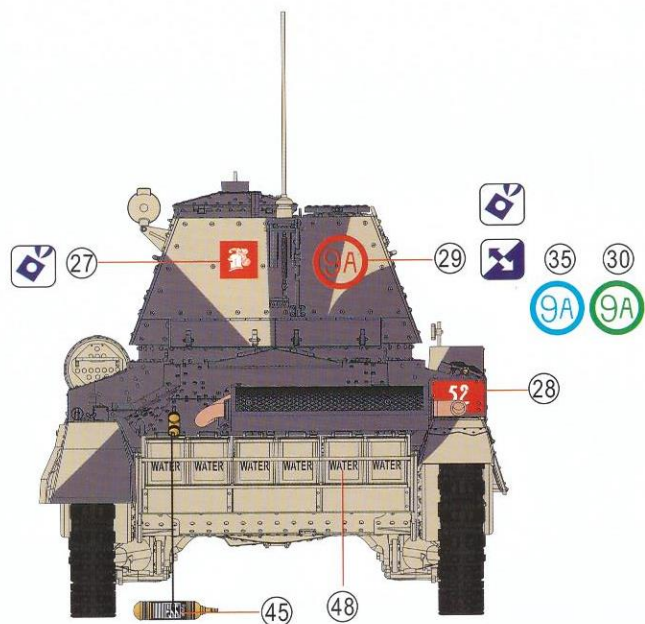
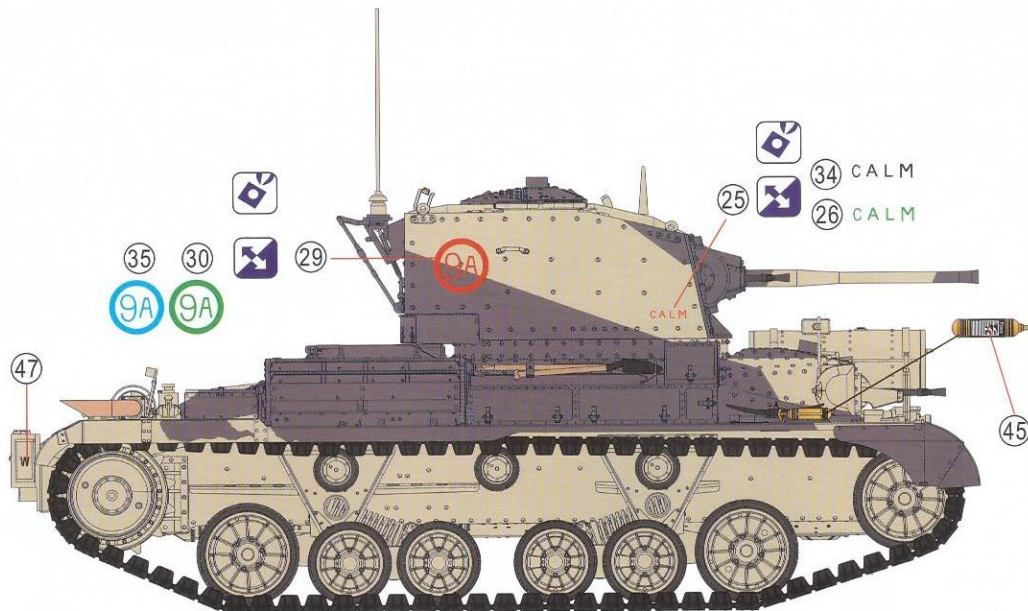
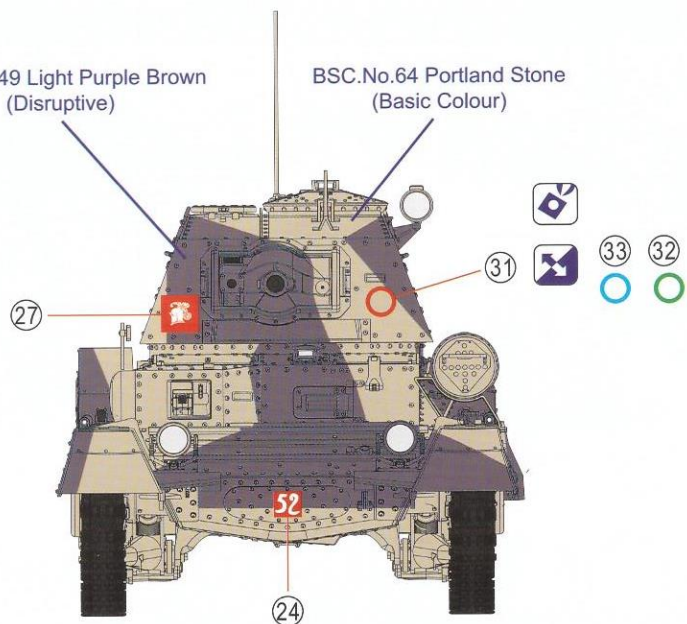

Option 4: HQ, 2<sup>nd</sup> Royal Tank Regiment, 1<sup>st</sup> Armoured Division, UK 1940.

Khaki Green No.3  
(Basic Colour)(G3)

Dark Green No.4  
(Disruptive)(G4)

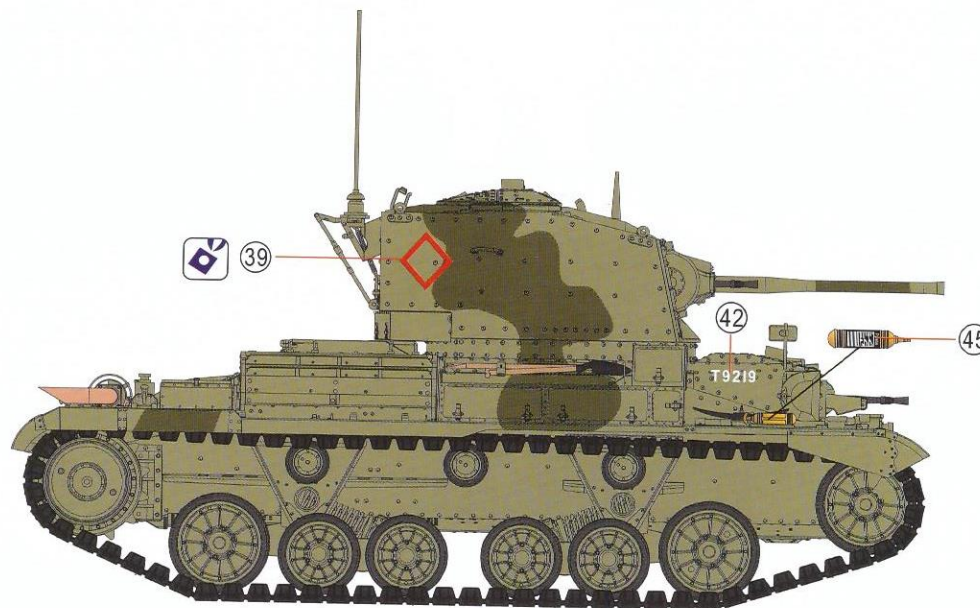
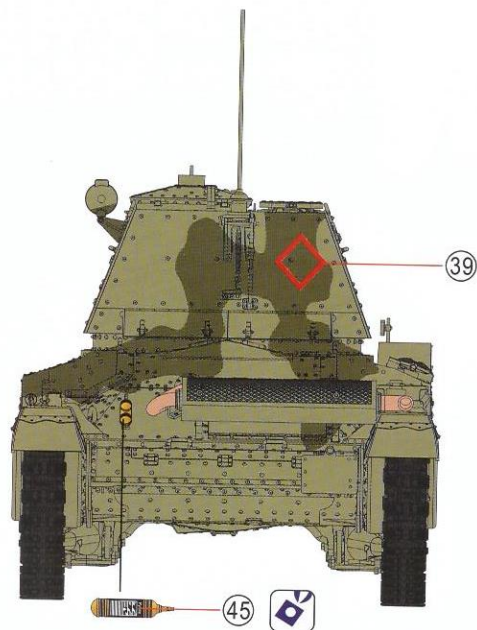
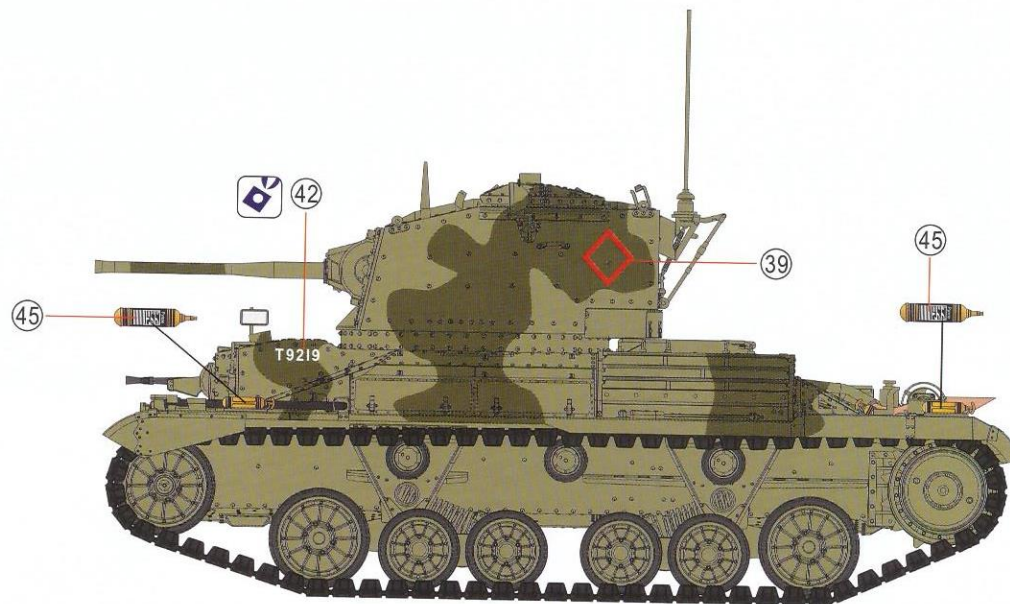
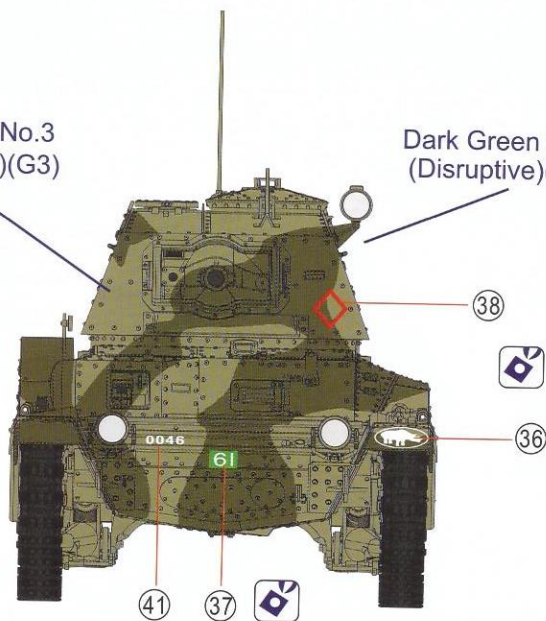

Option 5 : HQ,Squadron,2<sup>nd</sup> Royal Tank Regiment,7<sup>st</sup> Armoured Division,Libya 1940~1941.

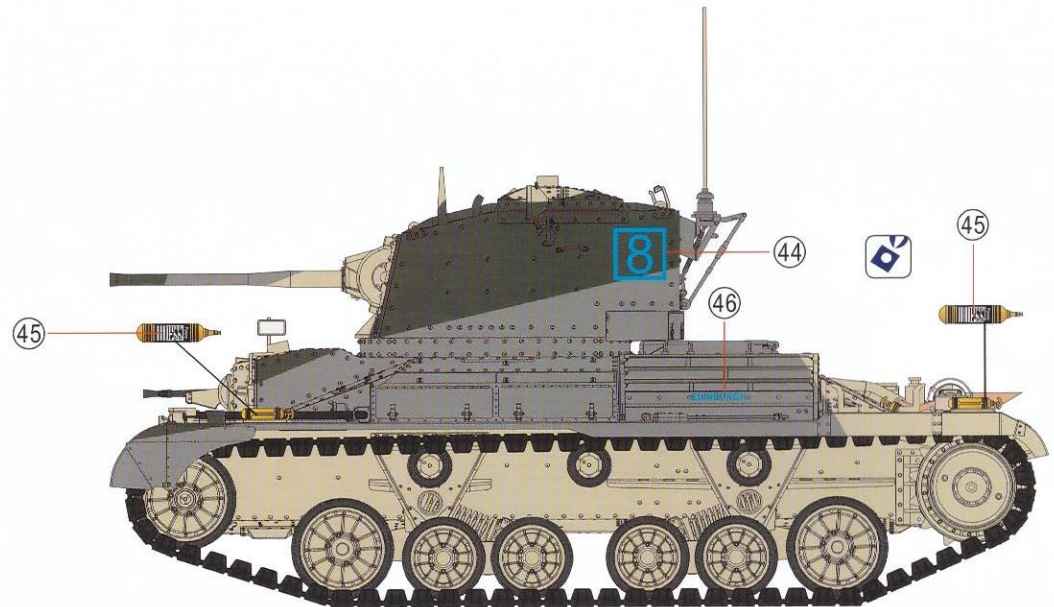
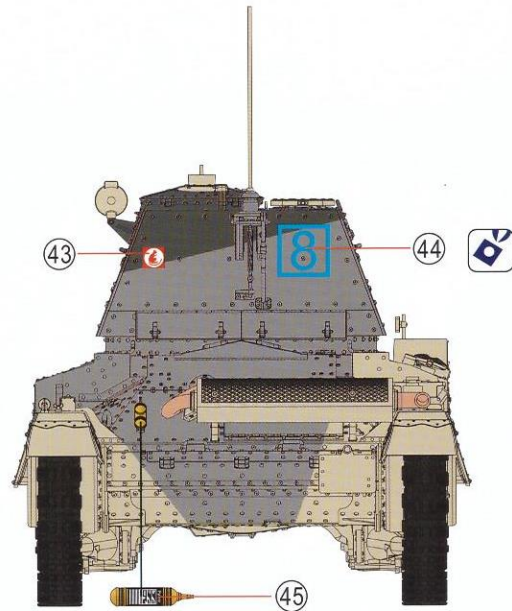
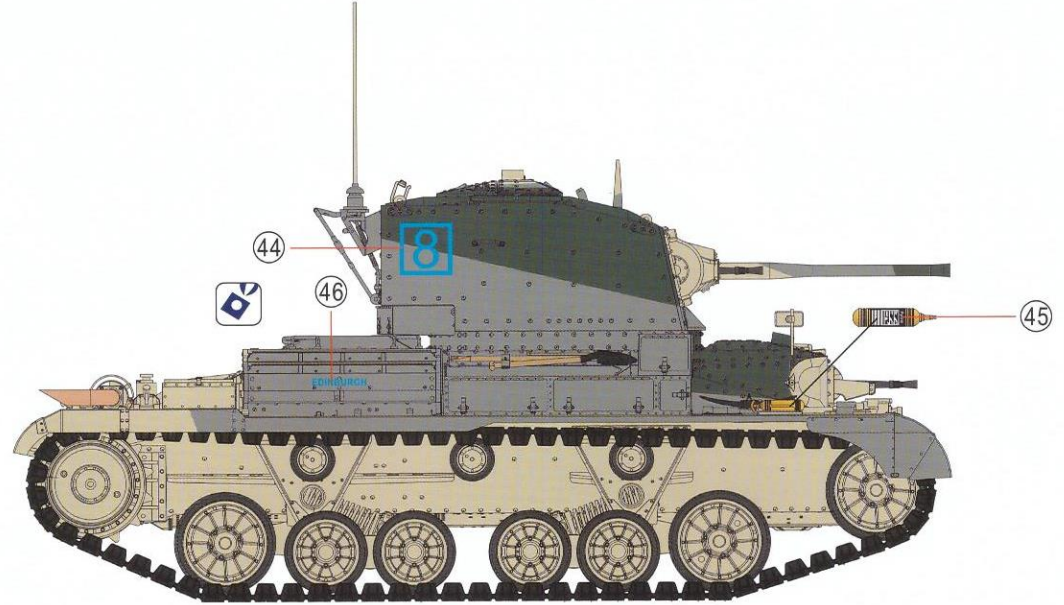
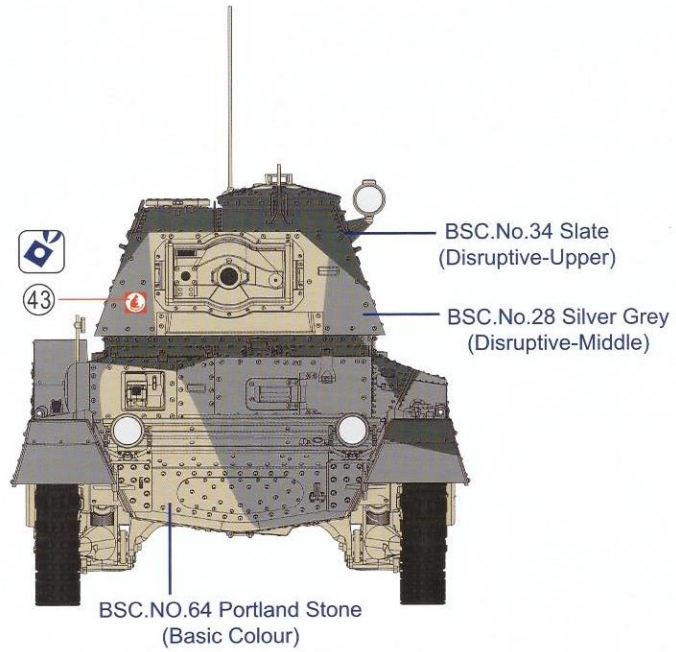

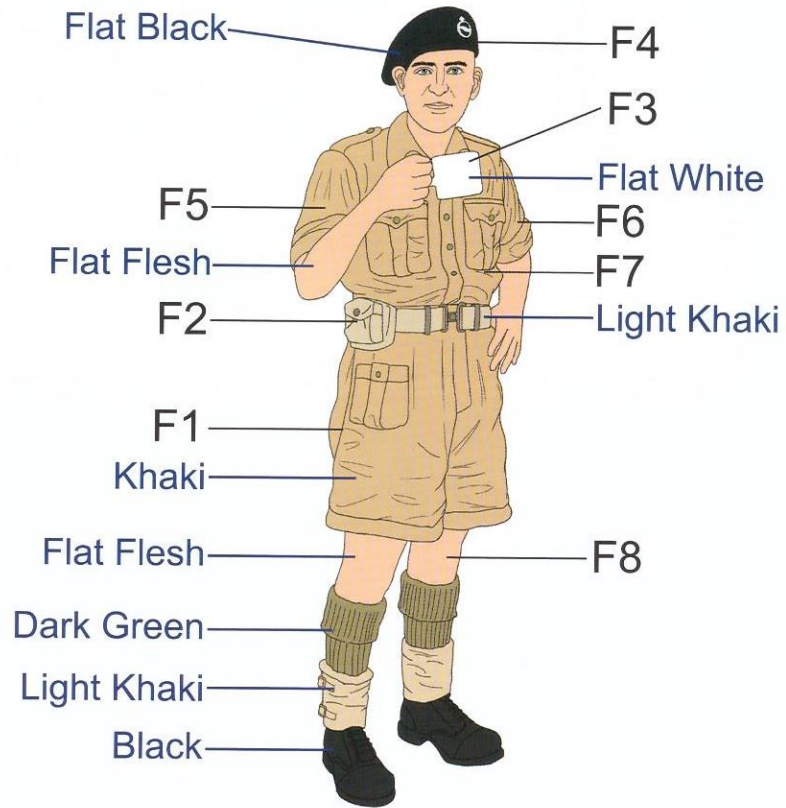

Many thanks to below gentlemen & company to provide their great assistance for our project:-

- Model Centrum Progres
- Robert Gregory
- Andrew Gadd
- Simon King

**Caution**



Please read the instruction sheet once carefully before assembly your model kit.

\*When use the glue or paint, do not near open flame and use in ventilated room.

\* The models that have not been assembled are stored in a dry place to avoid direct sunlight exposure.

**Attention**

\*Our Product can build for 2 different options, one is standard version & other one is desert version.