

**1** MiG-15 bis Fagot B, Soviet Air Force, flown by Soviet ace Nikolay Shkodin (credited with 4 F-86s and 1 F-84); North Korea, 1953.

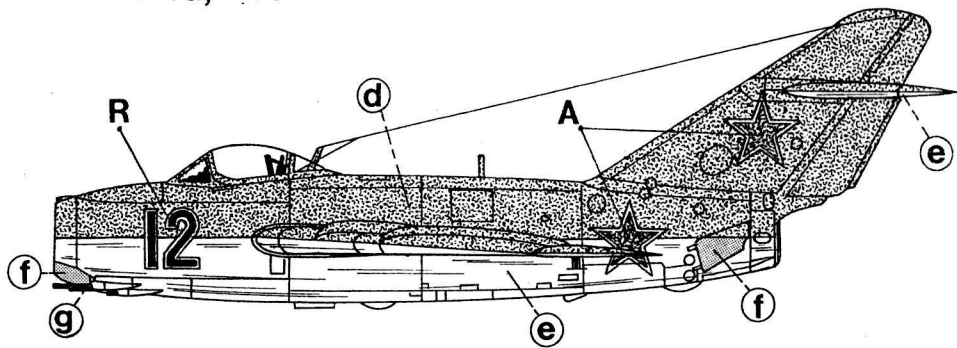

**2** MiG-15 bis Fagot B, Soviet Air Force Aerobatic Team, 1954.

H<sub>2</sub>  
72-022 & 48-009

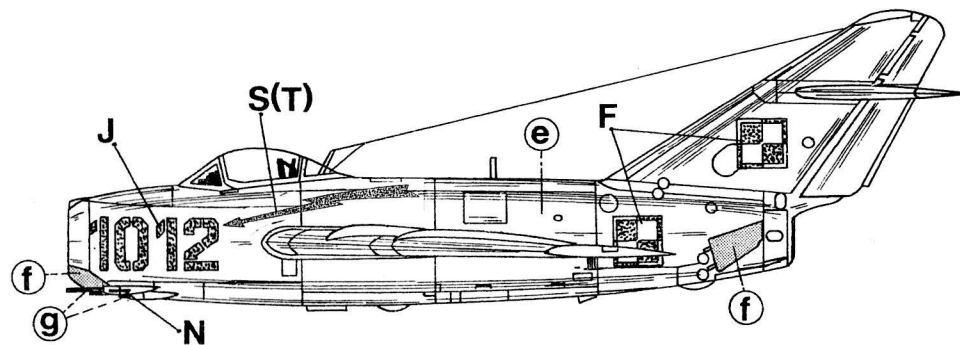

**3** Lim-2 Fagot B, 1st Fighter Regiment "Warszawa", Polish Air Force, Mińsk Mazowiecki A.B., 1959.

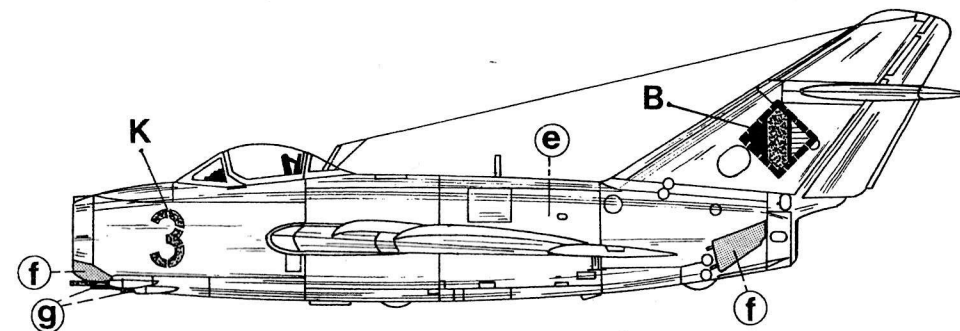

**4** MiG-15 bis Fagot B, East German Air Force, 1957.

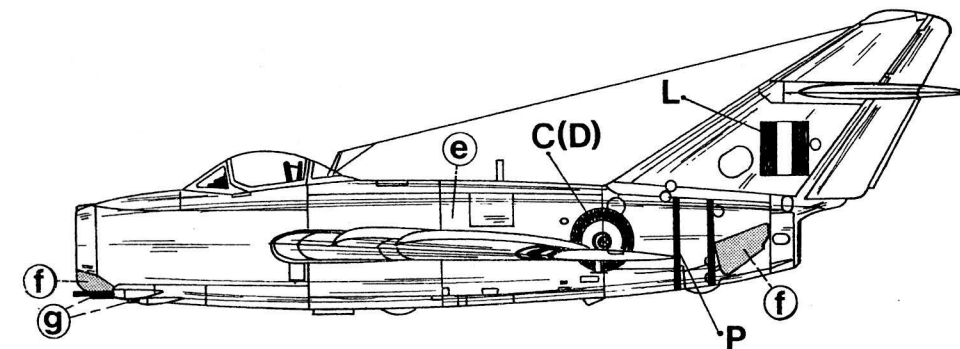

**5** MiG-15 bis Fagot B, Egyptian Air Force; Sinai, October 1956.

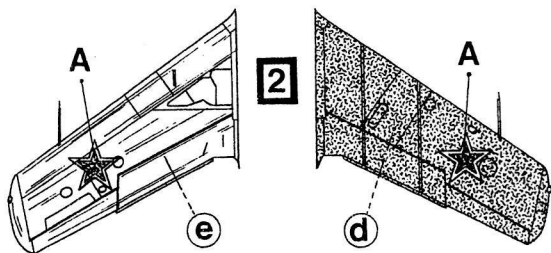
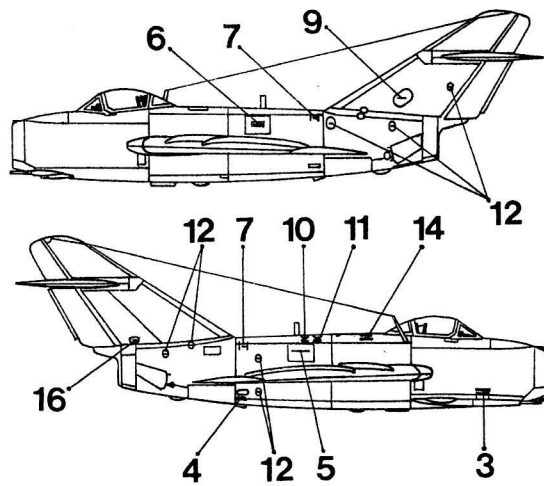
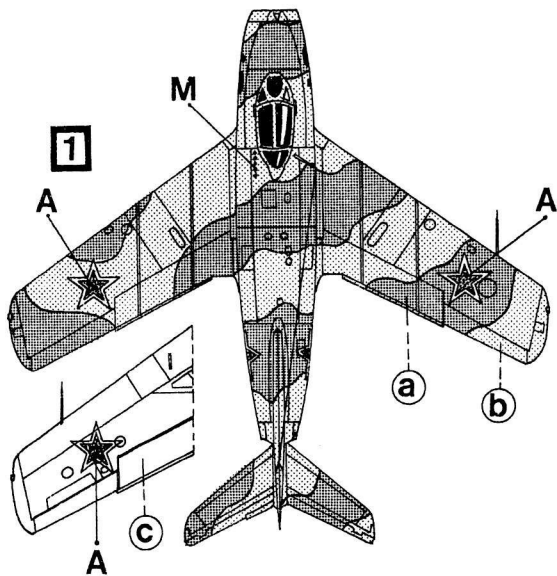

**2**: Stencilling on upper surfaces painted over.

\* **3** & **4** only!

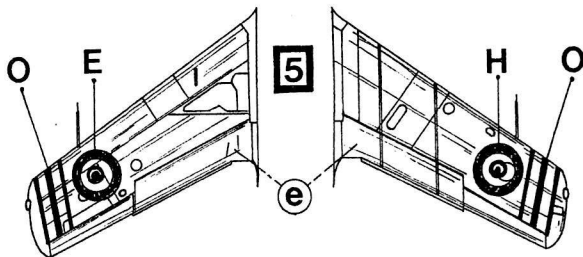
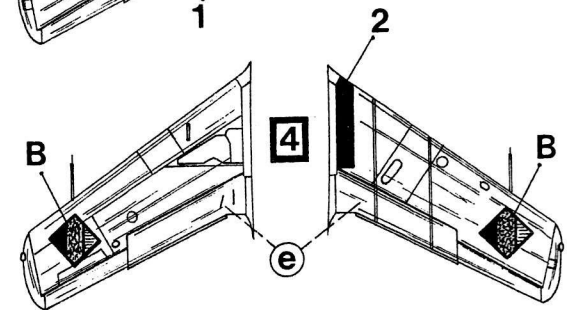
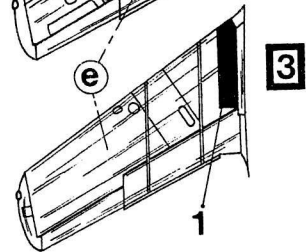
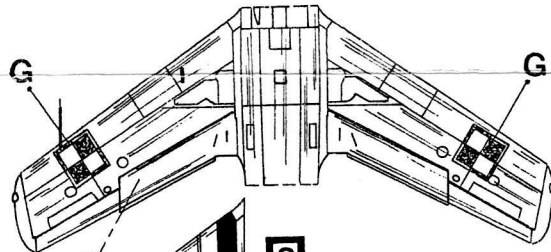
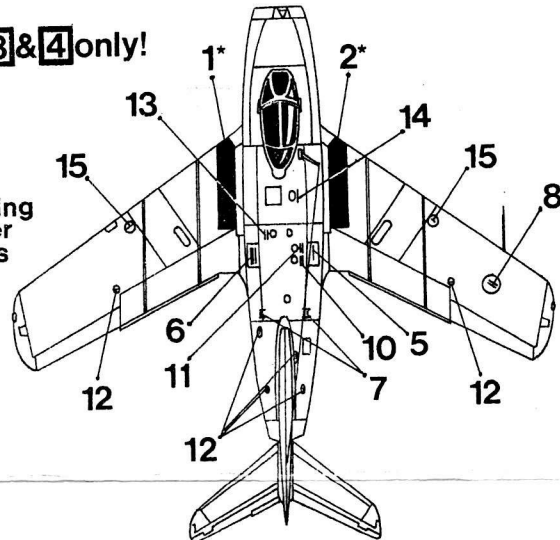

Scheme **1** based on drawings published in 'PLASTIC KITS REVUE' n°11 and 'KRILIA RODINY'.

Scheme **3** based on drawings published in 'BUDOWA PLASTYKOWYCH MODELI SAMOLOTÓW' by Krzysztof Wagner.

Recommended reference:  
'MIG-15 IN ACTION' by Hans-Heiri Stapfer Squadron/Signal publications n°116.

# MIG-15 BIS FAGOT B

72-022 & 48-009

		Humbrol	Model Master
a	Dark Green FS 34128	114	—
b	Light Brown FS 30257	63	1735
c	Light Blue FS 35488	47, 75% 34+ 25%	1508, 75% 1768+ 25%
d	Gloss Red FS 11140	19	1590
e	Aluminium	Metalcote	1401
f	Steel	Metalcote	1402
g	Gun Metal	Metalcote	1405