

**IAF-47**



**Israeli Air Force**

**F-16A/B Netz**

**1:48**



  
**IsraDecal**

### F-16A/B "The Negev Squadron"

This was the 3rd squadron to receive the F-16A/B in 1981. The original Mirage/ Neshet squadron insignia was replaced in the mid '80s with one featuring an F-16 silhouette inside. This a/c #290 has 2 kill marks of Syrian MiGs.

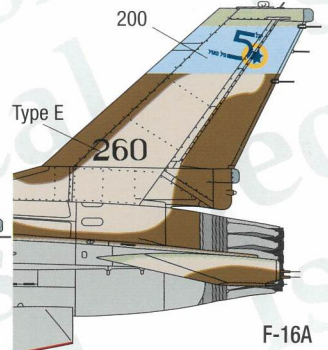
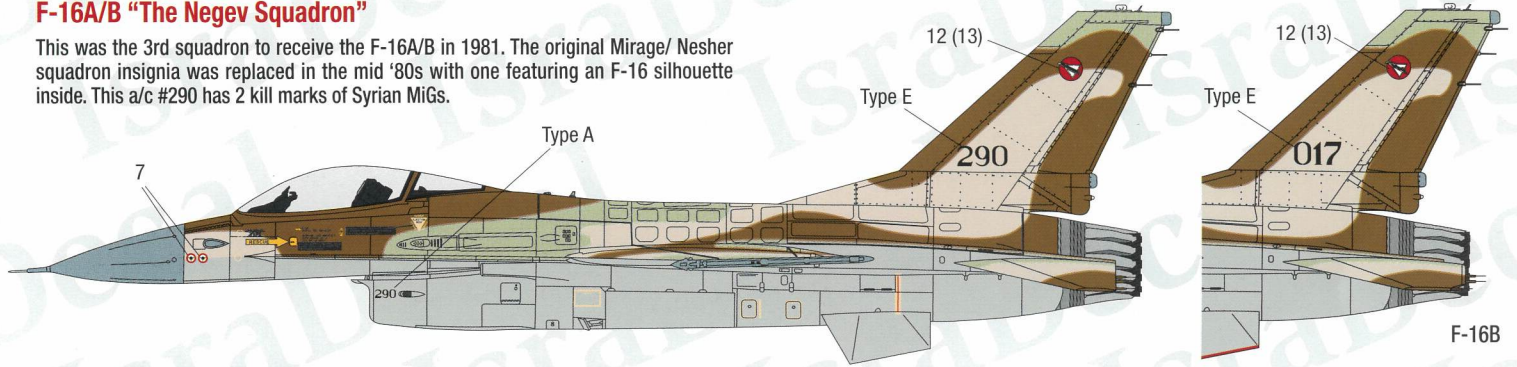

### F-16A/B "Golden Eagle Squadron"

This is the 4th squadron to operate the F-16A/Bs and also serve as an OTU squadron.

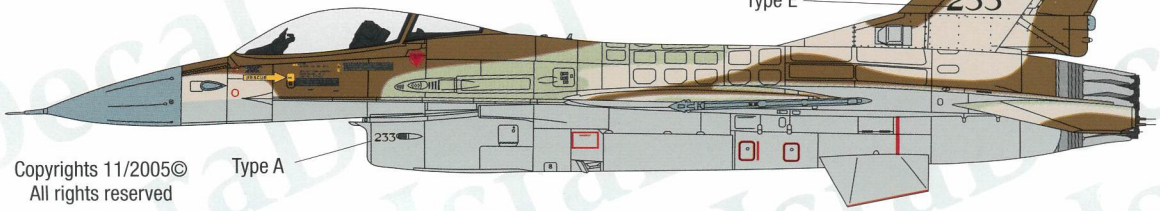

Copyrights 11/2005©  
All rights reserved

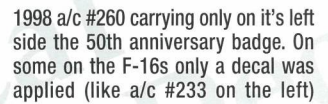

1998 a/c #260 carrying only on it's left side the 50th anniversary badge. On some on the F-16s only a decal was applied (like a/c #233 on the left)



### F-16A/B "The Golden Eagle Squadron"

Golden Eagle squadron's 50th anniversary fin markings initially applied in 1999.

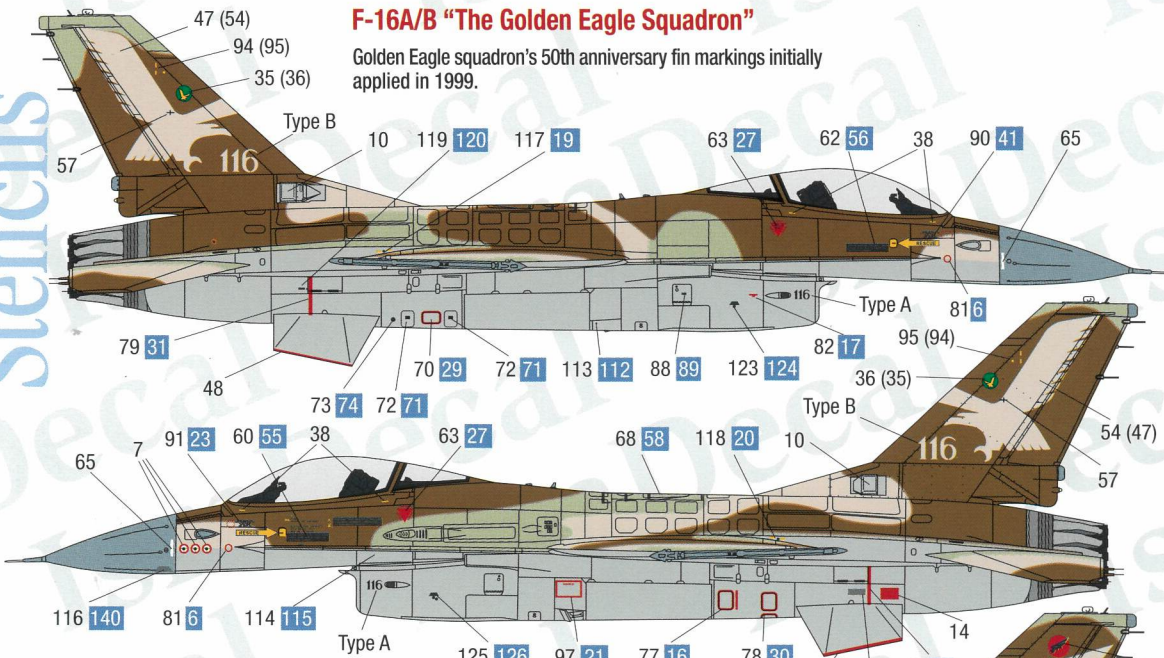

### General stencils for F-16A/Bs

Index:  
Decal Regular stencils for the original stencils.  
Decal Stencils in black box for the Israeli painted stencils.

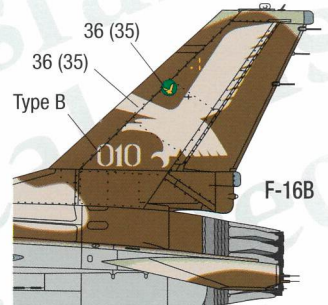

### F-16A/B "Flying Wing Squadron" 2003

In the first half of 2003, the Flying Wing squadron has been reformed as an F-16A/B squadron, receiving the planes of the Negev squadron which will receive the new F-16I at the end of 2003.

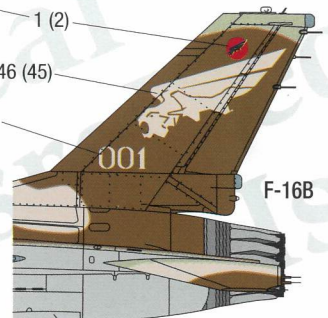
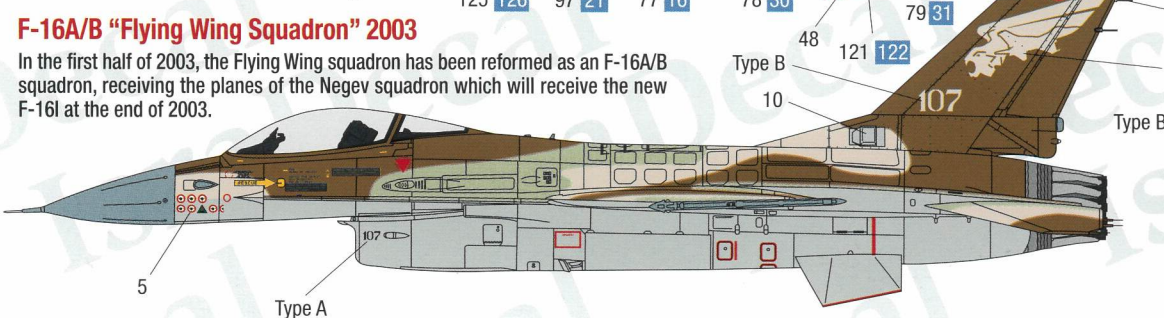



Above: Golden Eagle squadron, F-16A #243 as seen in spring 2003.

Right: Flying Wing squadron F-16As #126 as seen in Ovda AF Base in August 2005.



**IsraDecal** Copyrights 11/2005©  
All rights reserved



Left: Golden Eagle squadron, F-16A #246 as seen over the Negev Desert in the early 1990's.

Below: Negev squadron F-16As #107 and #126 over the Northern Arava Desert. Circa late 1990's.



### F-16A/B "The Phoenix Squadron"

This squadron's F-16s are ex-USAF F-16s which came to Israel in 1994 and served with the American gray scheme for several years. They carried the original American stencils. During major maintenance, the a/c were painted with the standard camouflaged colour scheme.

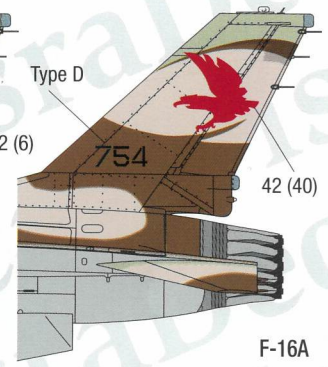
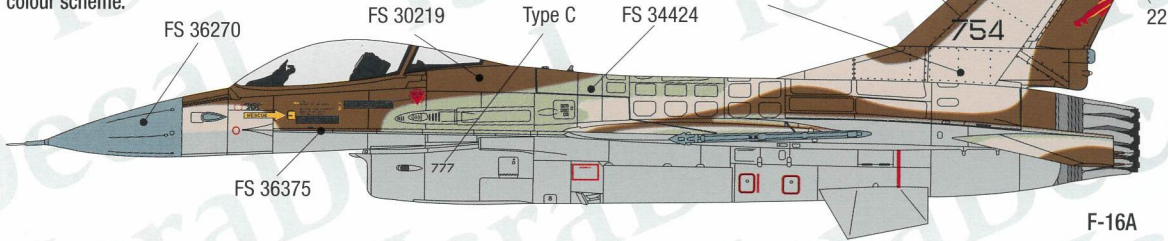

### F-16A "The Flying Dragon Squadron"

This squadron operates as an Aggressor squadron and train all IAF fighter squadrons. The squadron operates F-16A, AH-1S Cobras and Anti Aircraft batteries. The tail are has been designed by Ra'anam Weiss. The plane usually carry two Red painted training AIM-9L missiles and are painted centerline fuel tank.

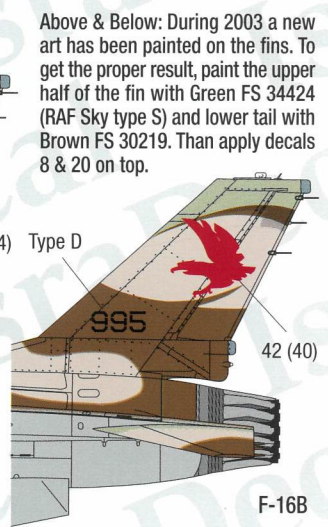
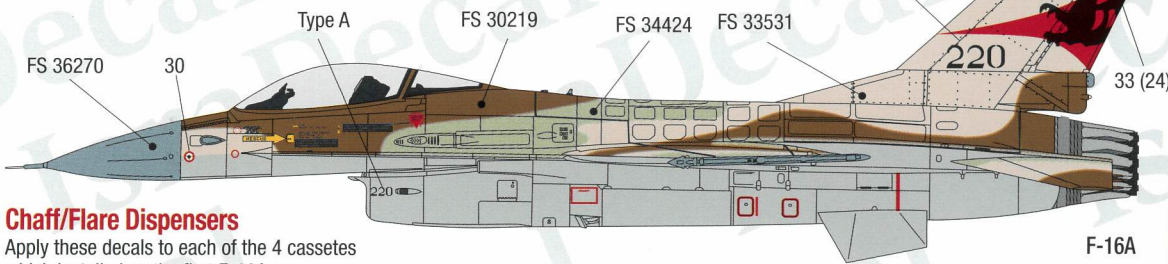

Above & Below: During 2003 a new art has been painted on the fins. To get the proper result, paint the upper half of the fin with Green FS 34424 (RAF Sky type S) and lower tail with Brown FS 30219. Than apply decals 8 & 20 on top.

### Chaff/Flare Dispensers

Apply these decals to each of the 4 cassettes which installed on the first F-16A

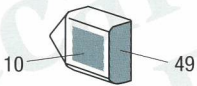

### General Stencils for F-16A/Bs

Index:

- Decal Regular stencils for the original stencils.
- Decal Stencils in Black box for the Israeli painted stencils

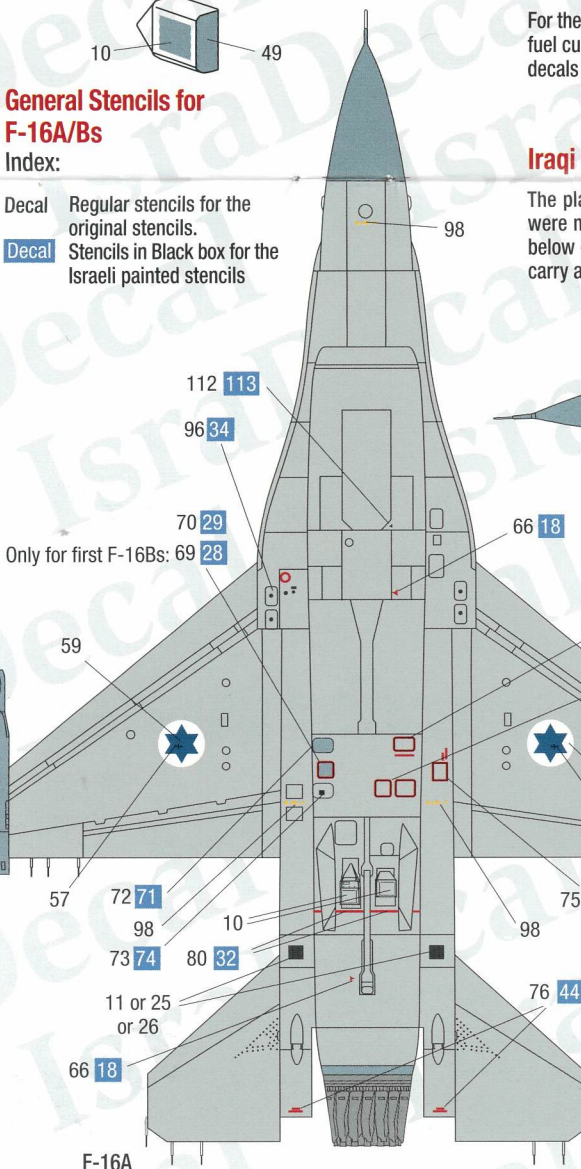

For the external fuel tanks use the following decals for the fuel cups: decals #37 for the wing's 370 gallon tanks and decals #43 for the 300 gallon center line tank.

### Iraqi Nuclear Plant Kill Mark

The planes that attacked the Iraqi nuclear plant in 1981 were marked with a special kill mark (decal #9). The a/c below - #129 belong to the Flying Wing squadron and also carry a half Syrian kill mark (decal #8).

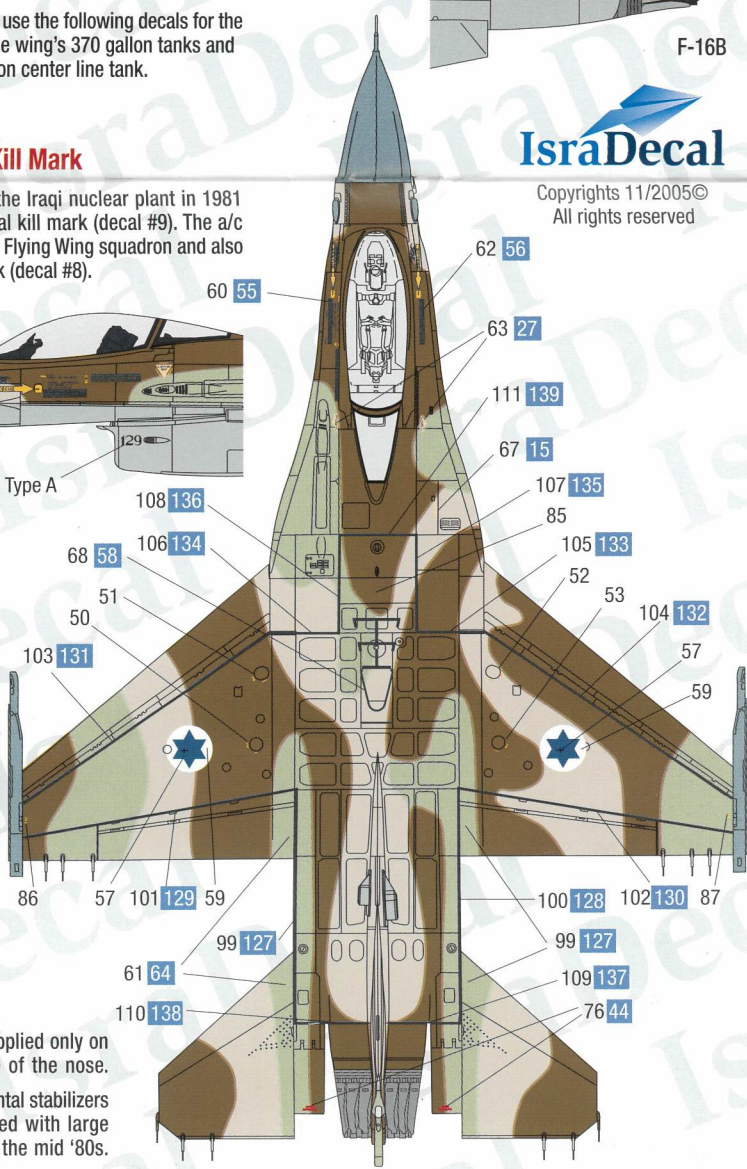
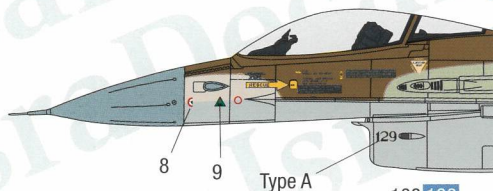

- Notes:
- Kill marks applied only on the left side of the nose.
  - Small horizontal stabilizers were replaced with large ones during the mid '80s.



Copyrights 11/2005© All rights reserved

