

# AeroMaster Decals™

3615 NW 20th Ave • Miami, Florida 33142 • USA  
 Tel. (305) 633-7398 • Fax (305) 638-4197

48-222

## Operation Bodenplatte

### Pt. 1

ME-109G-14, Wr. Nr. 462892, 16/JG 53, January 1, 1945. This aircraft was flown by Gefreiter Alfred Michel on his first mission and shot down by anti-aircraft fire from the 90th Inf. Division, US Army at Halstroff, France. Pilot was taken prisoner. Scheme is RLM 81/83 on upper surfaces with spots of RLM 83. Undersides are RLM 76. Note that landing gear door covers are not installed.

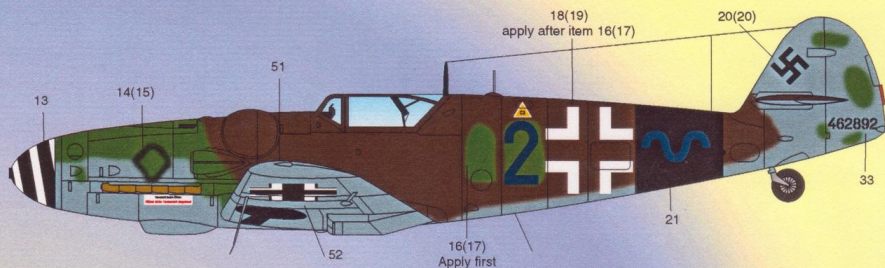

ME-109G-14, 12/JG53, January 1, 1945. This aircraft was believed to have participated in the New Year's Day attack. Scheme is RLM 81/83 on upper surfaces with circular spots of RLM 83. Undersides are RLM 76. Underside of nose cowling is RLM 04 yellow. Note that landing gear door covers are not installed.

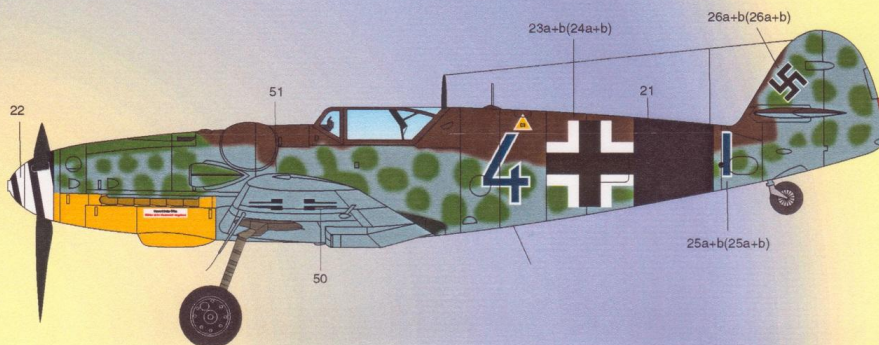

FW-190A-9, Wk. Nr. 980219, 2/JG 1, January 14, 1945. Flown by Pilot Officer Wilhelm Ade who was shot down in a dogfight with several Spitfires. Pilot survived with injuries. Note slightly rotated form of swastika and hand painted propellor markings shown on next page.

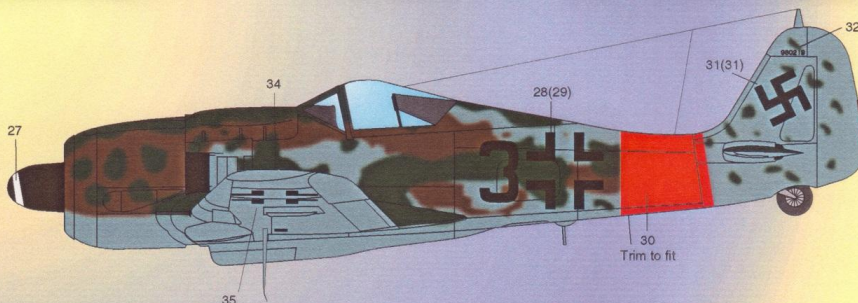

FW-190A-8/R8, Wk. Nr. 681497, 5/JG 4, January, 1945. Flown by Gefreiter Walter Wagner, this aircraft belly landed at St. Trond airfield and was made flyable by 404th Fighter Group, US Army. Scheme is RLM 74/75 over RLM 76. Cowling panel with emblem on left side is probably from another aircraft.

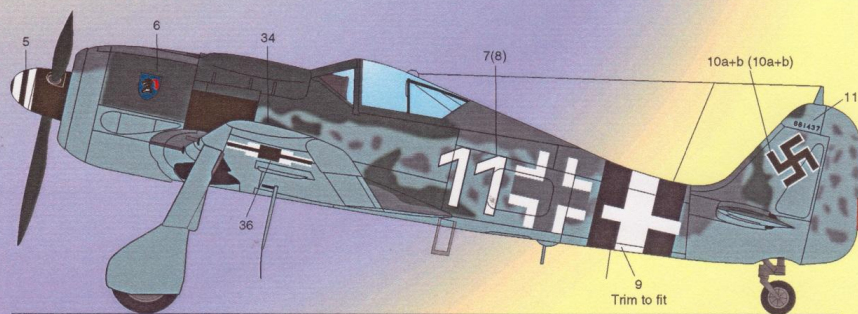

Copyright © 1997

RLM 70	RLM 74	RLM 75	RLM 76	RLM 81	RLM 82	RLM 83	RLM 04	RLM 23	RLM 24
FS 34050	FS 34086	FS 36122	FS 36473	FS 34045	FS 34079	FS 34138	FS 33538	FS 31140	FS 25053



# AeroMaster Decals™

Fw-190D-9, Wk. Nr. 281617, unit unknown, January 1, 1945. Aircraft filmed taking off with AB250 cluster bomb on ETC 504 weapon rack. Scheme is RLM 82/83 on upper surfaces and RLM 76 on lower surfaces. Note partially overpainted white stripe on rear fuselage.

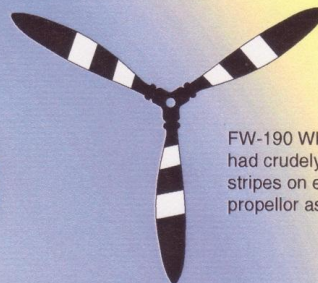
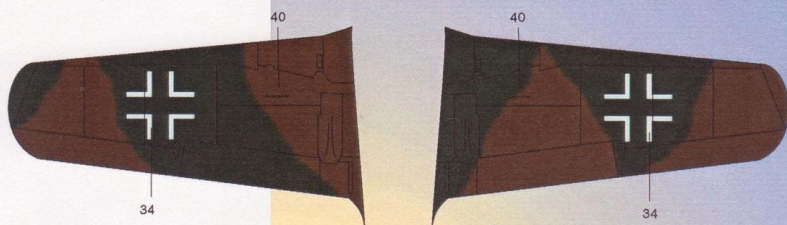
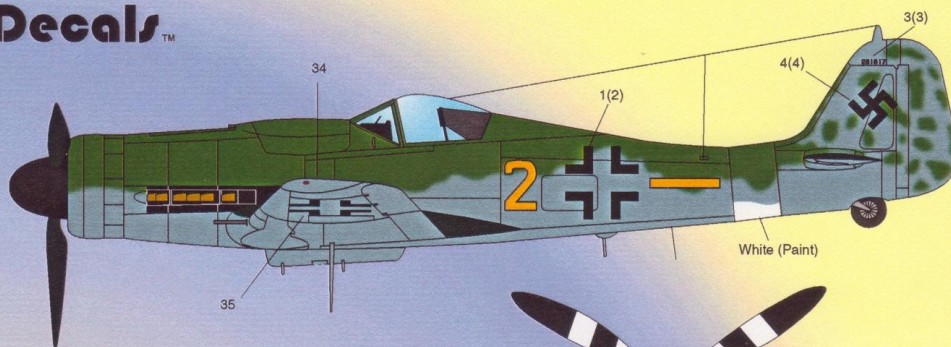

FW-190 Wk. Nr. 980219 had crudely painted white stripes on each blade of the propeller as shown above.

## FW-190 WING MARKING LOCATIONS

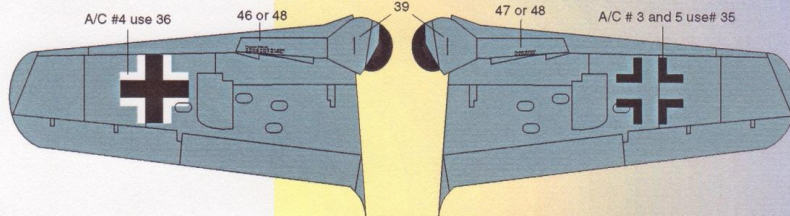

FW-190 Tailplane camouflage pattern

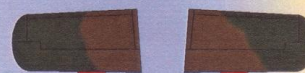

ME-109 Tailplane camouflage pattern

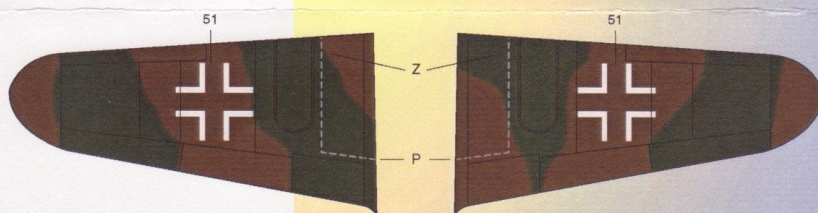

## ME-109 WING MARKING LOCATIONS

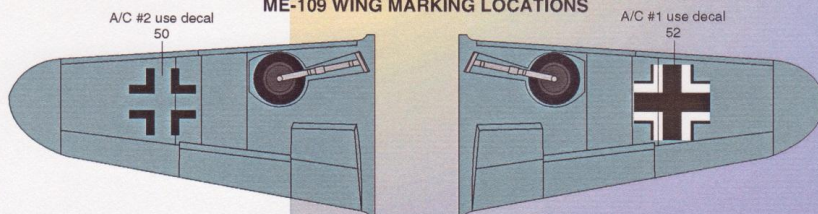

## Suggested Kits:

1. DML Fw-190D Family
2. Fujimi ME-109G Family
3. Tamiya Fw-190A Family

### Recommended AeroMaster Warbird Colors Enamels

9001 Black	9025 RLM 74 Graugrün
9002 White	9026 RLM 75 Grauvlett
9003 Yellow	9027 RLM 76 Lichtblau
9004 Blue	9028 RLM 81 Braunviolett
9005 Red	9029 RLM 81 A Braunviolett
9010 Tire Black	9030 RLM 82 Dunkelgrün
9023 RLM 70 Schwzgrün	9031 RLM 83 Lichtgrün
9024 RLM 71 Dunkelgrün	9036 RLM 04 Gelb

### Recommended AeroMaster Warbird Colors Acrylic

1001 Gloss Clear	9025 RLM 74 Graugrün
1002 Semi-Gls Clr	9026 RLM 75 Grauvlett
1003 Flat Clear	9027 RLM 76 Lichtblau
1004 Tire Black	9028 RLM 81 Braunviolett
1014 RLM 23 Red	9029 RLM 81 A Braunviolett
1015 RLM 24 Blue	9030 RLM 82 Dunkelgrün
9023 RLM 70 Schwzgrün	9031 RLM 83 Lichtgrün
9024 RLM 71 Dunkelgrün	9036 RLM 04 Gelb

## References:

1. *Posledni' Sa'zka*, REVI Magazine, Number 3, 1995. Published by REVI Publications, Czech Republic, pp. 14-20. Several color plates of Operation Bodenplatte aircraft included showing the last three aircraft on this sheet.
2. *Posledni' Sa'zka*, REVI Magazine, Number 4, 1995, pp. 12-17. Continuation of above article on Operation Bodenplatte. Includes one color plate showing the first two aircraft on this sheet.

If you have suggestions for future subject matter, AeroMaster would like to hear from you. Our goal is to provide high quality, well researched decals of unusual and interesting subjects. We value our customers' input, so if you have specific suggestions or photographs of unusual subject matter which you would be willing to share, please contact:

**AeroMaster Decals™**  
3615 NW 20th Ave • Miami, Florida 33142 • USA



# AeroMaster Decals™

Fw-190  
GENERAL STENCIL &  
MARKINGS PLACEMENT

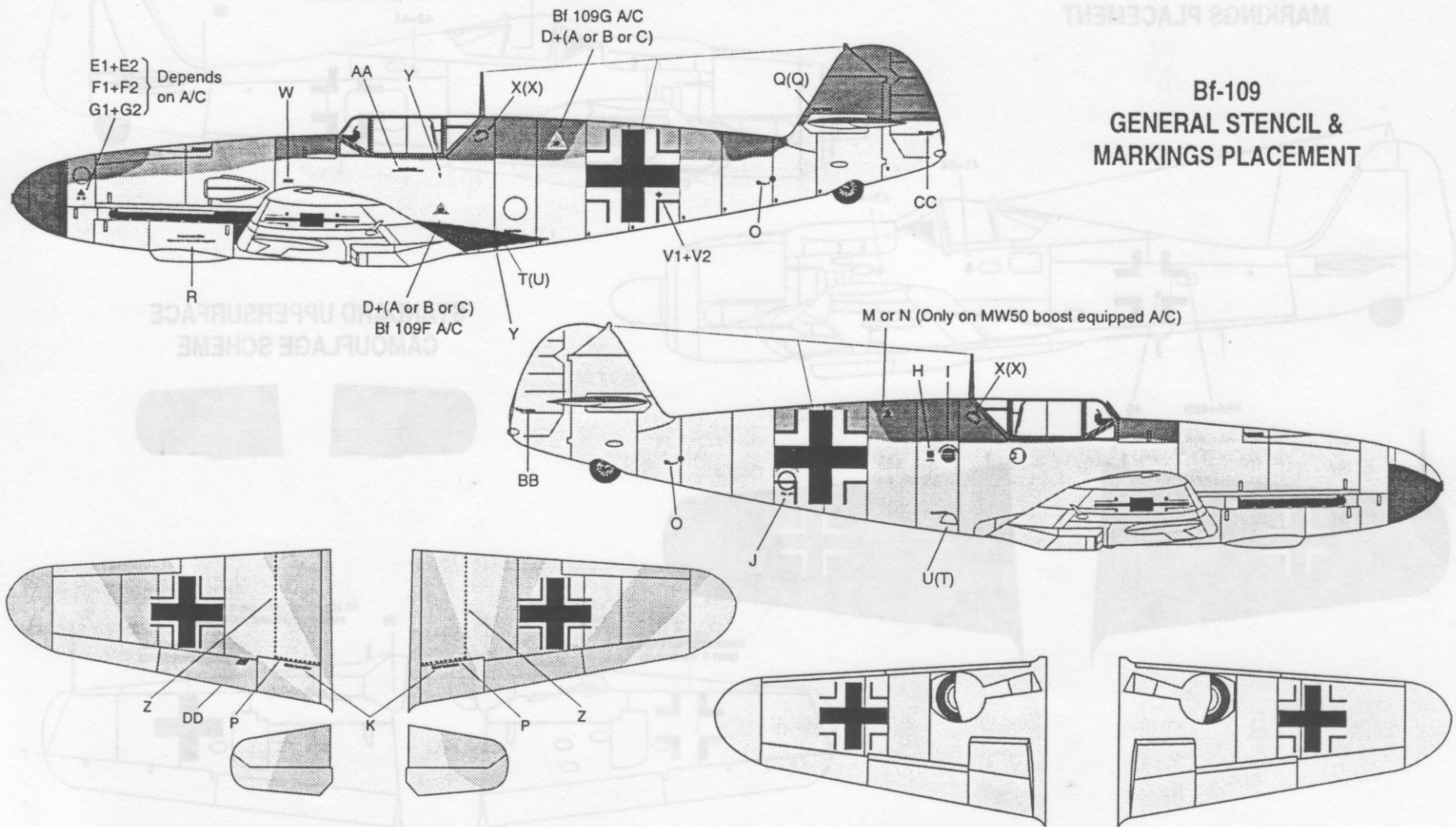

## Bf-109 GENERAL STENCIL & MARKINGS PLACEMENT

**Fw-190  
GENERAL STENCIL &  
MARKINGS PLACEMENT**

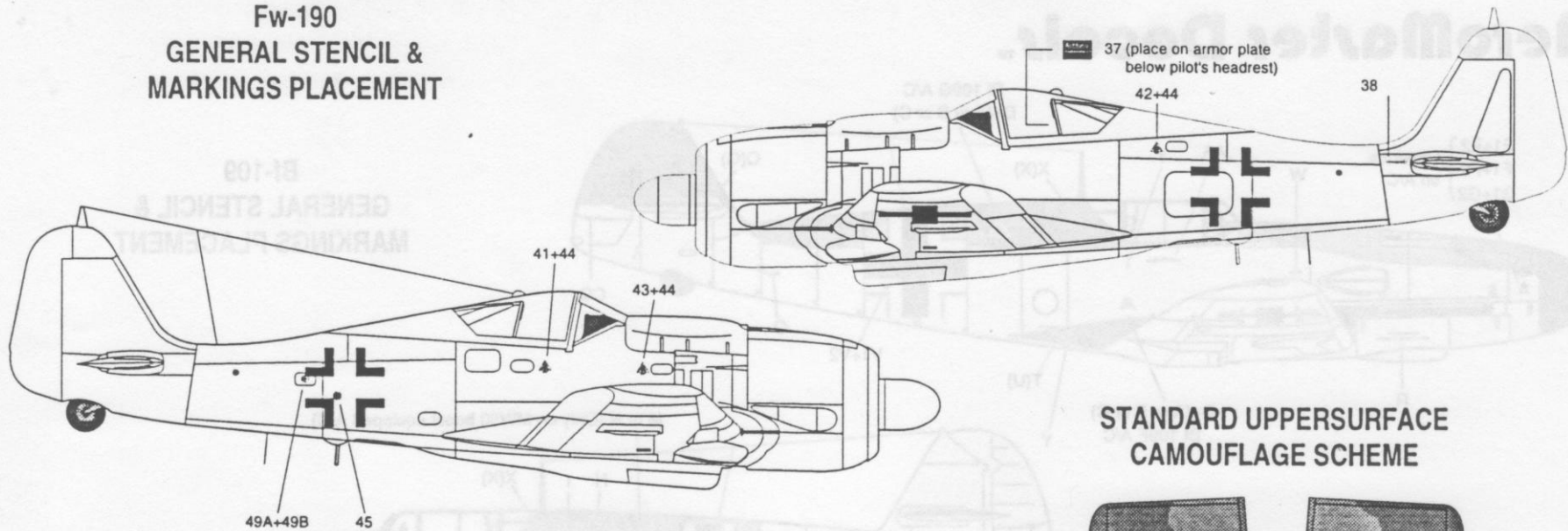

**STANDARD UPERSURFACE  
CAMOUFLAGE SCHEME**

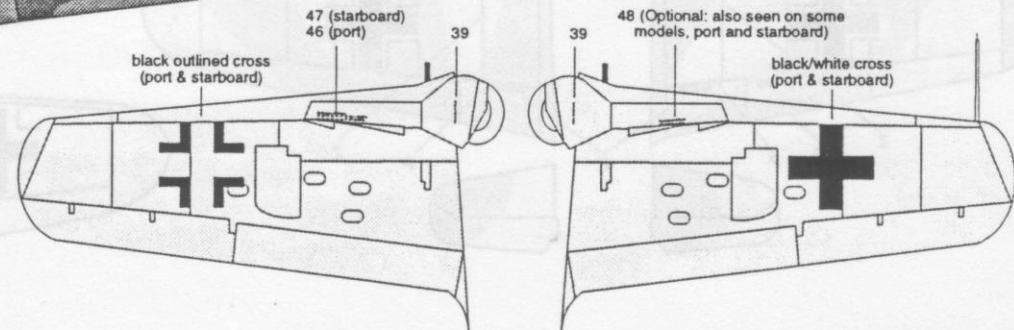
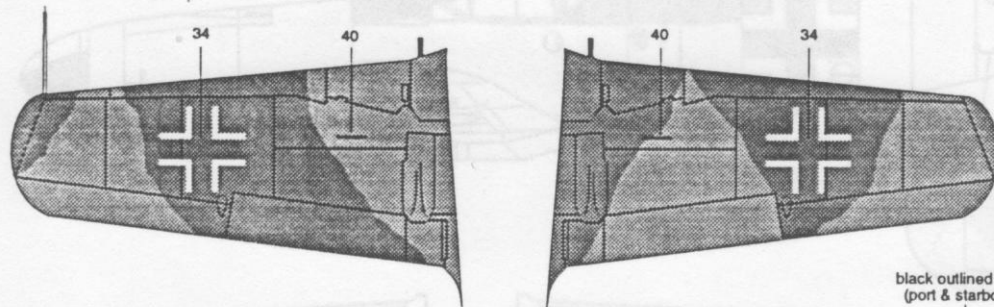
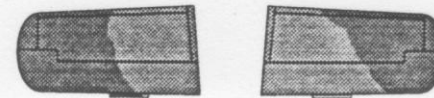

**Aeromaster Decals™**

**Aeromaster Decals** Operation Bodenplatte Pt. 1 48-222B

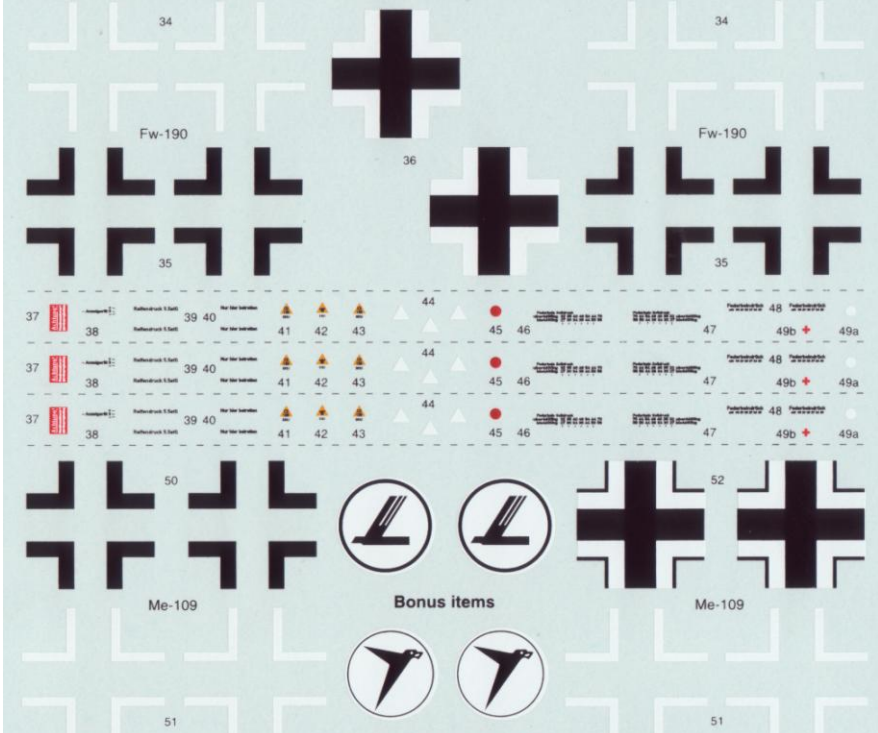

Copyright © 1/1996 Q>M

A	B	C	D	E2	F2	G2	E1	F1	G1	H	I	J	K	L	M	N	O
P	Q	R	S	T	U	V2	V1	W	X	Y	Z	AA	BB	CC	DD		

**Me-109**

A	B	C	D	E2	F2	G2	E1	F1	G1	H	I	J	K	L	M	N	O
P	Q	R	S	T	U	V2	V1	W	X	Y	Z	AA	BB	CC	DD		

**Aeromaster Decals** Operation Bodenplatte Pt. 1 48-222A



Copyright © 1/1996 Q>M

10b	10a	20	26a	26b	31
-----	-----	----	-----	-----	----