

MIL Mi-4 "HOUND"

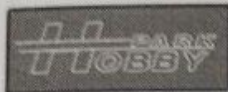

1/72
72104

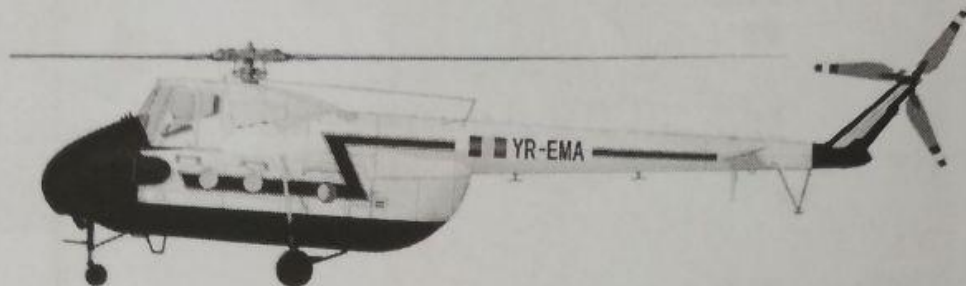

RO

Elicopterul Mi-4 a fost produs de Biroul de Proiectări Mil aflat sub îndrumarea renumitului proiectant de elicoptere sovietic, Mihail Leontevicei Mil. Pentru OKB Mil, Mi-4 a însemnat primul produs care s-a bucurat de un mare succes în exploatare atât în URSS cât și în alte țări. Au fost produse aproximativ 3.500 de aparate în perioada 1952-1966.

De-a lungul anilor au apărut aparate care puteau îndeplini o gamă largă de misiuni. Mi-4 fiind produs în variante specializate ASW (Anti-Submarine Warfare / luptă anti-submarin), ECM (Electronic Counter-Measures / luptă electronică și bătăi), transport marfă, transport pasageri, sanitar, agricol ș.a.m.d.

Varianta militară putea lua la bord 14 militari sau un vehicul de comandă tip GAZ-69 și avea ca armament o mitralieră grea de 12,7 mm. Opțional, Mi-4 putea fi dotat și cu rachete antitanc "Falanga" și lansatoare de rachete calibrul 57 mm.

Elicopterul Mi-4 a participat la diverse conflicte militare de-a lungul anilor Războiului Rece, fiind introdus în luptă încă de timpuriu. Ar fi de menționat intervențiile sovietice din Ungaria (1956), Cehoslovacia (1968) și Afghanistan (1979) unde elicopterele au jucat un rol major datorită doctrinei militare sovietice care prevedea acțiuni rapide cu trupe de parașutiști și trupe cu destinație specială.

Mi-4 a fost principalul elicopter din dotarea țărilor Pactului de la Varșovia în perioada anilor '60' și '70' printre acestea aflându-se și România. Primul elicopter Mi-4 a intrat în înzestrarea Forțelor Armate Române în iunie 1956 (elicopterul cu numărul de înmatriculare 127). În total România a avut în exploatare un număr de 16 aparate care au zburat până în anul 1977 când au fost scoase din dotare.

Mi-4 a fost produs și în China sub denumirea de Z-5, această versiune fiind și în zilele noastre zburată de FA ale Albaniei.

DATE TEHNICE

MotorAs-82V de 1 700CP
Diametru rotor21m
Lungime Fuselag 16,8m
Plafon6 000m

Incarcatura maxima 1 500kg
Viteza maxima 185km/h
Greutate maxima 7 800kg
Raza de actiune 400km

ENG

The Mi-4 helicopter was designed by the Mil design bureau, led by Mihail Leontevicei Mil. For OKB Mil, Mi-4 was the first export success, no less than 3500 were produced and exported in many countries between 1952-1966.

A very versatile helicopter, the Mi-4 was produced in transport, passenger, crop duster, ambulance, ASW, ECM and AT role.

The military version could carry 14 soldiers or a GAZ-69 command vehicle and was armed with a 12,7 mm machine gun. It could also carry with "Falanga" AT missiles or 57 mm rocket pods.

Mi-4 took part in many military operations in Hungary (1956), Czechoslovakia (1968), Afghanistan (1979).

It was the workhorse of the Warsaw Pact countries in the 60's and well into 70's. In Romania the first Mi-4 entered service in June 1956 (no 127).

The Mi-4 was also produced in China under Z-5 designation, this version is still in service.

Technical Data:

EngineAs-82V 1700HP
Rotor diameter21m
Fuselage length 16,8m
Ceiling6.000m

Max. Load 1500kg
Max. Speed 185 km/h
Take-Off weight 7.800kg
Range 400km

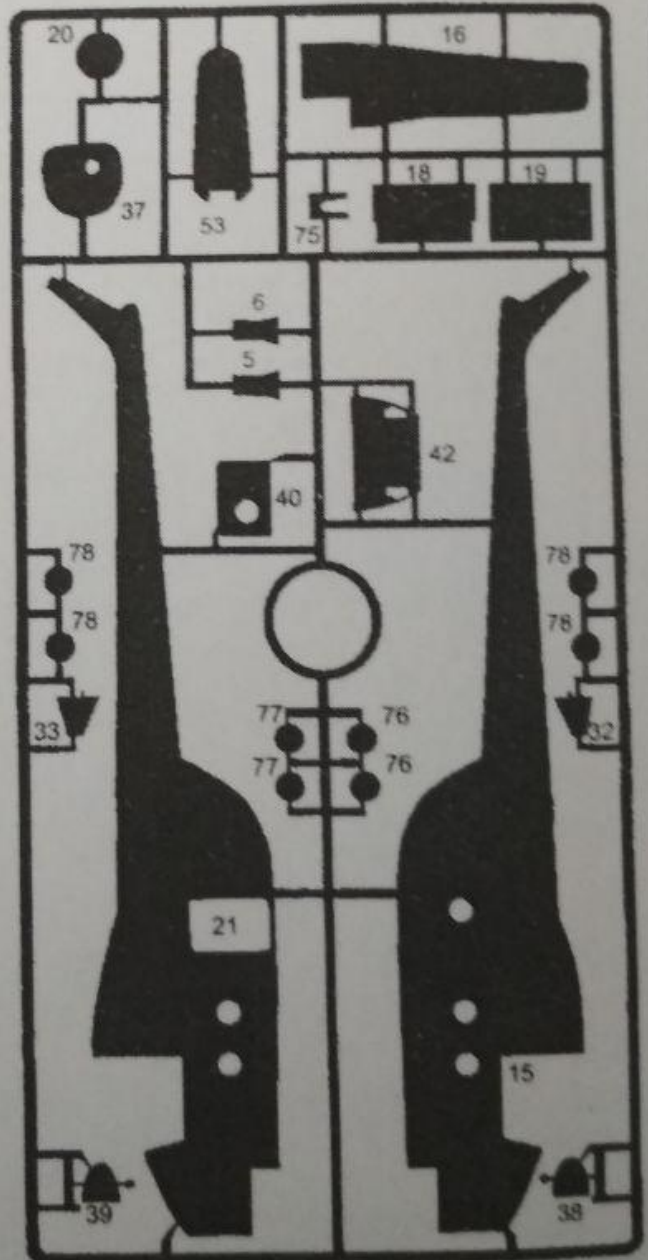
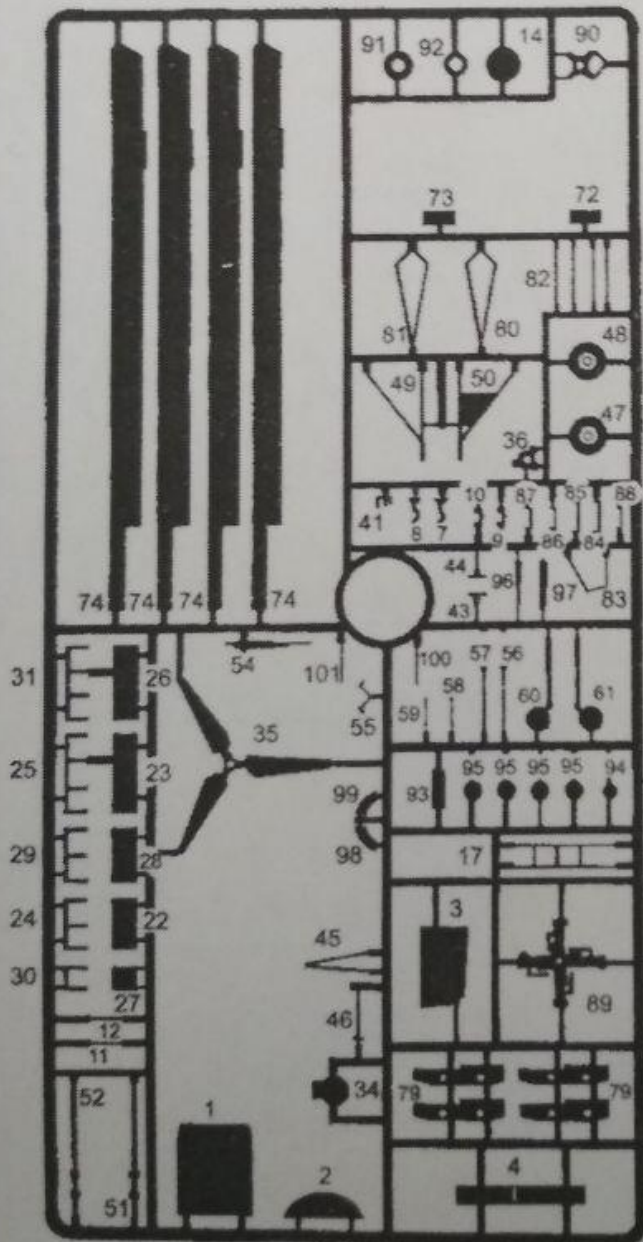
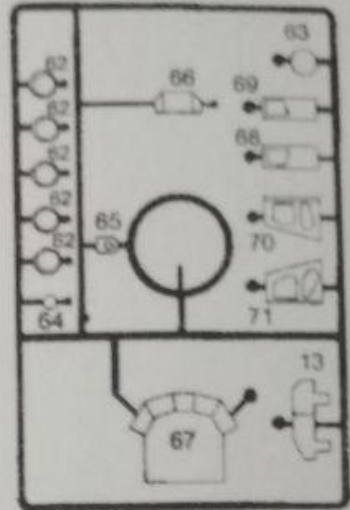
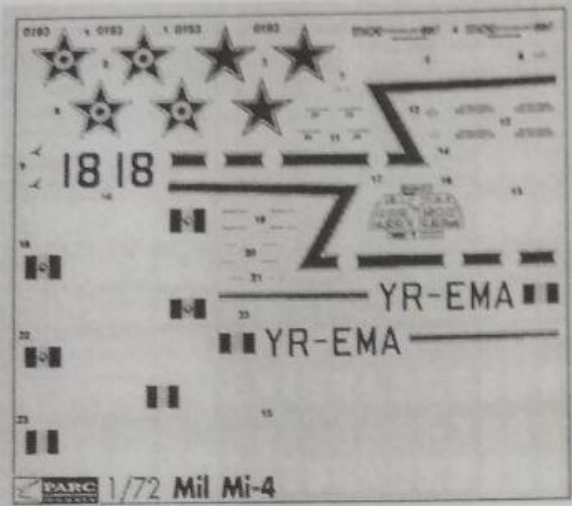

1
STEP



2
STEP

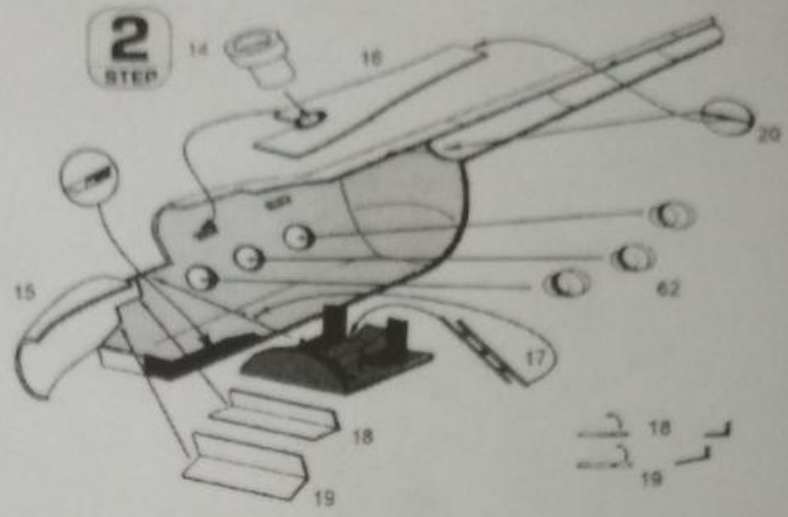

3
STEP

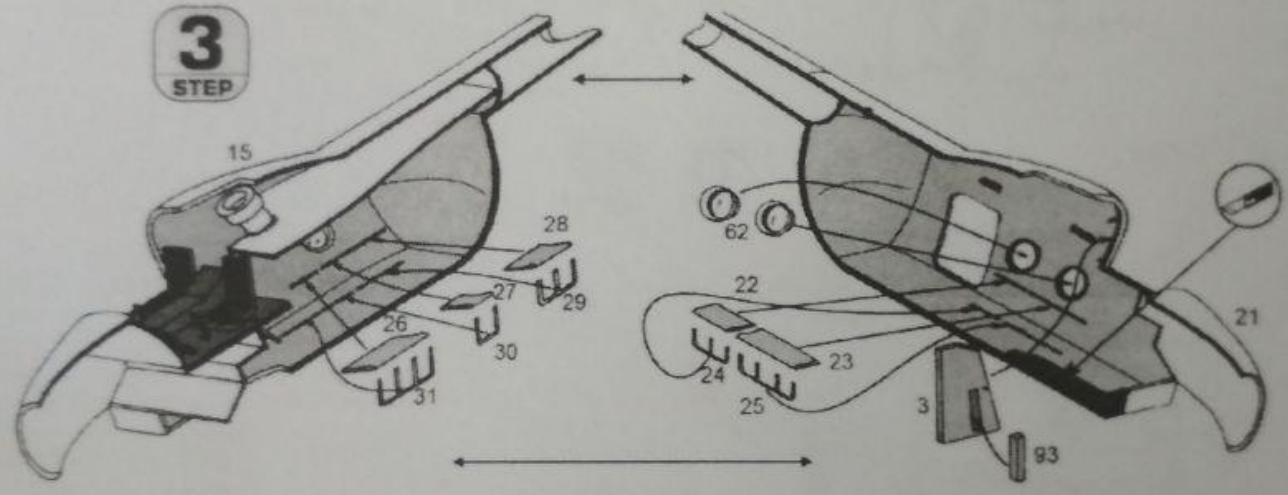

4
STEP

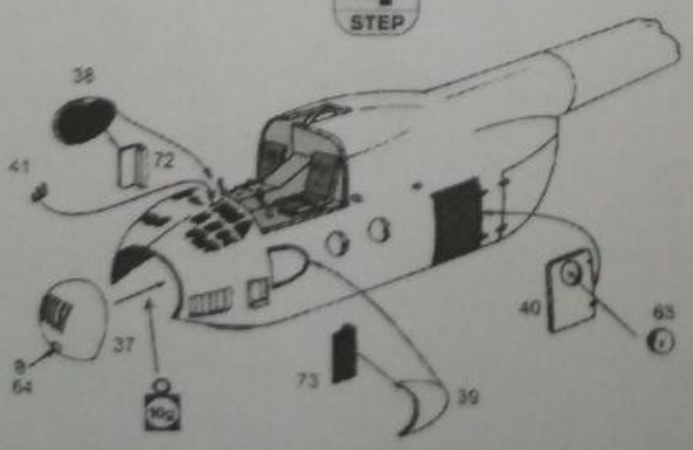

5
STEP

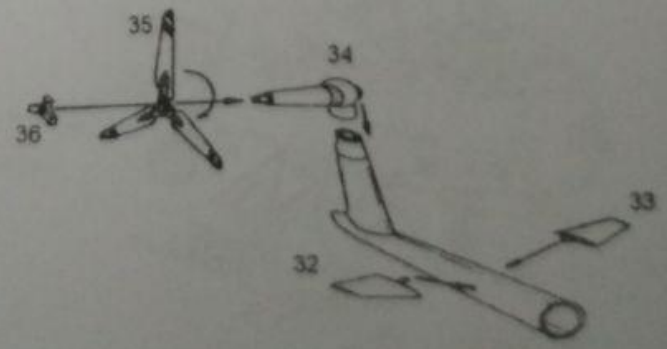

6
STEP

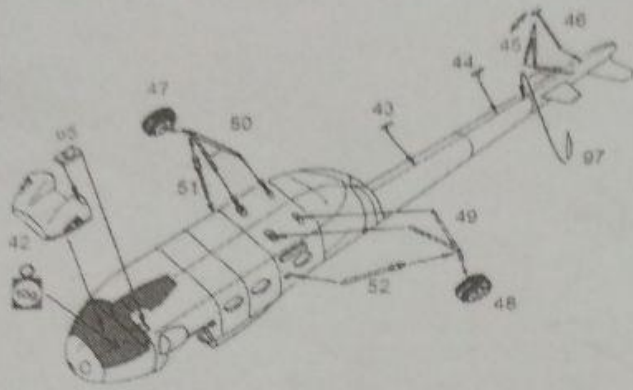

7
STEP

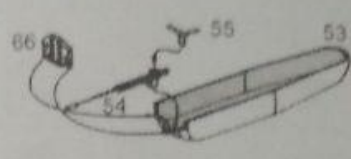

8
STEP

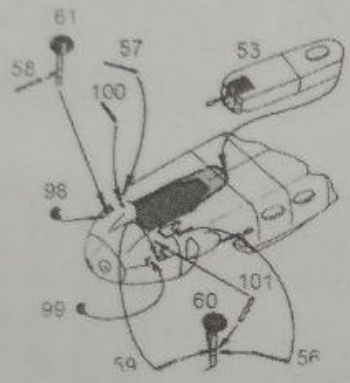

9
STEP

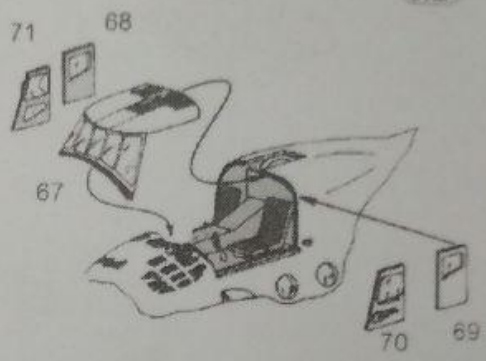

11
STEP

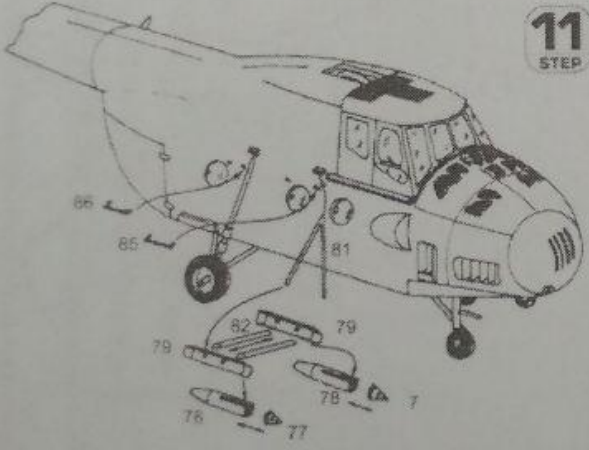

10
STEP

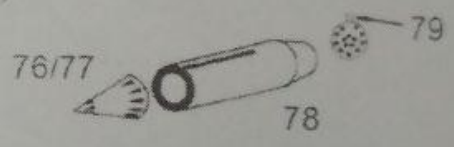

12
STEP



13
STEP

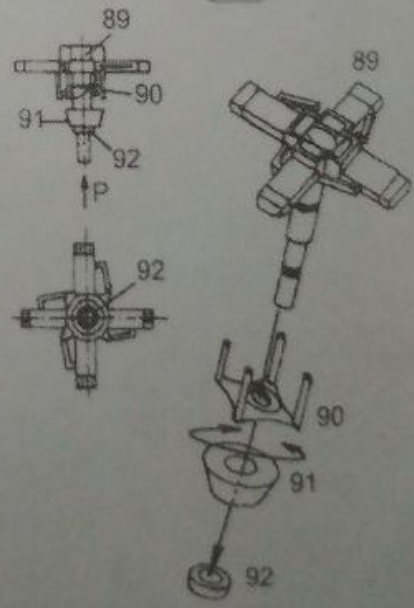

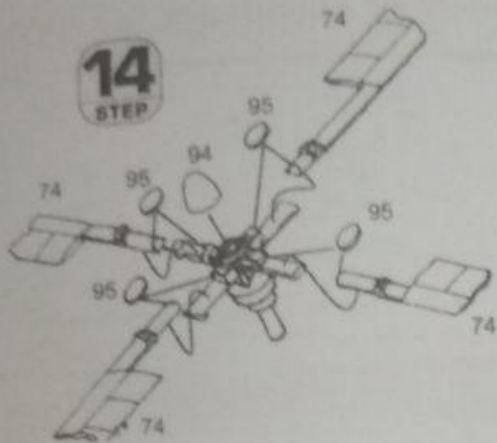

14
STEP

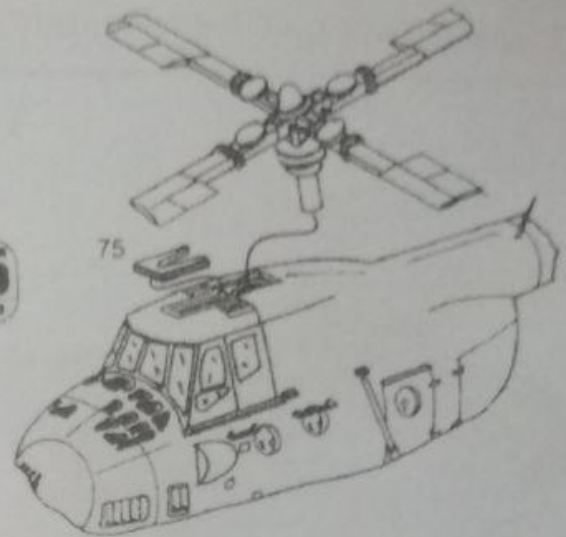

15
STEP

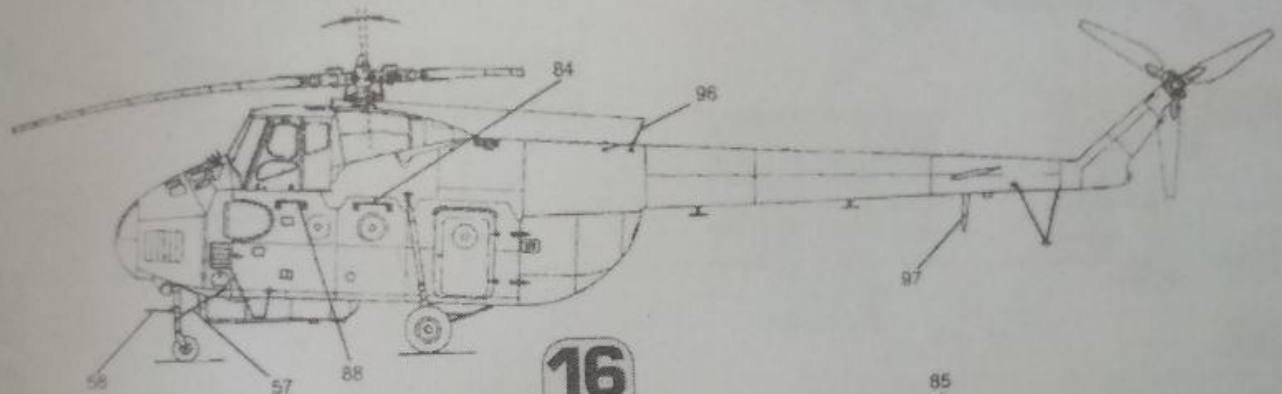

16
STEP

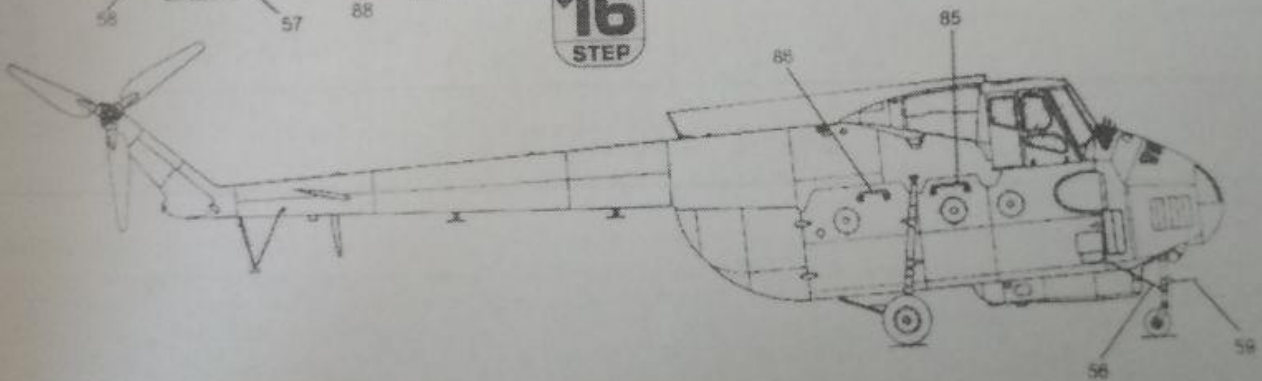

CULORI FOLOSITE / USED PAINT

A

Gren FS 34102

B

Ligh Blue

C

Black matt

D

Reddish Brown

E

Silver Metallic

F

Red

G

White

H

Blue

I

Middle Grey

SCHEMA DE VOPSIRE și ÎNMATRICULARE / SCHEME OF COLOURING and MARKING

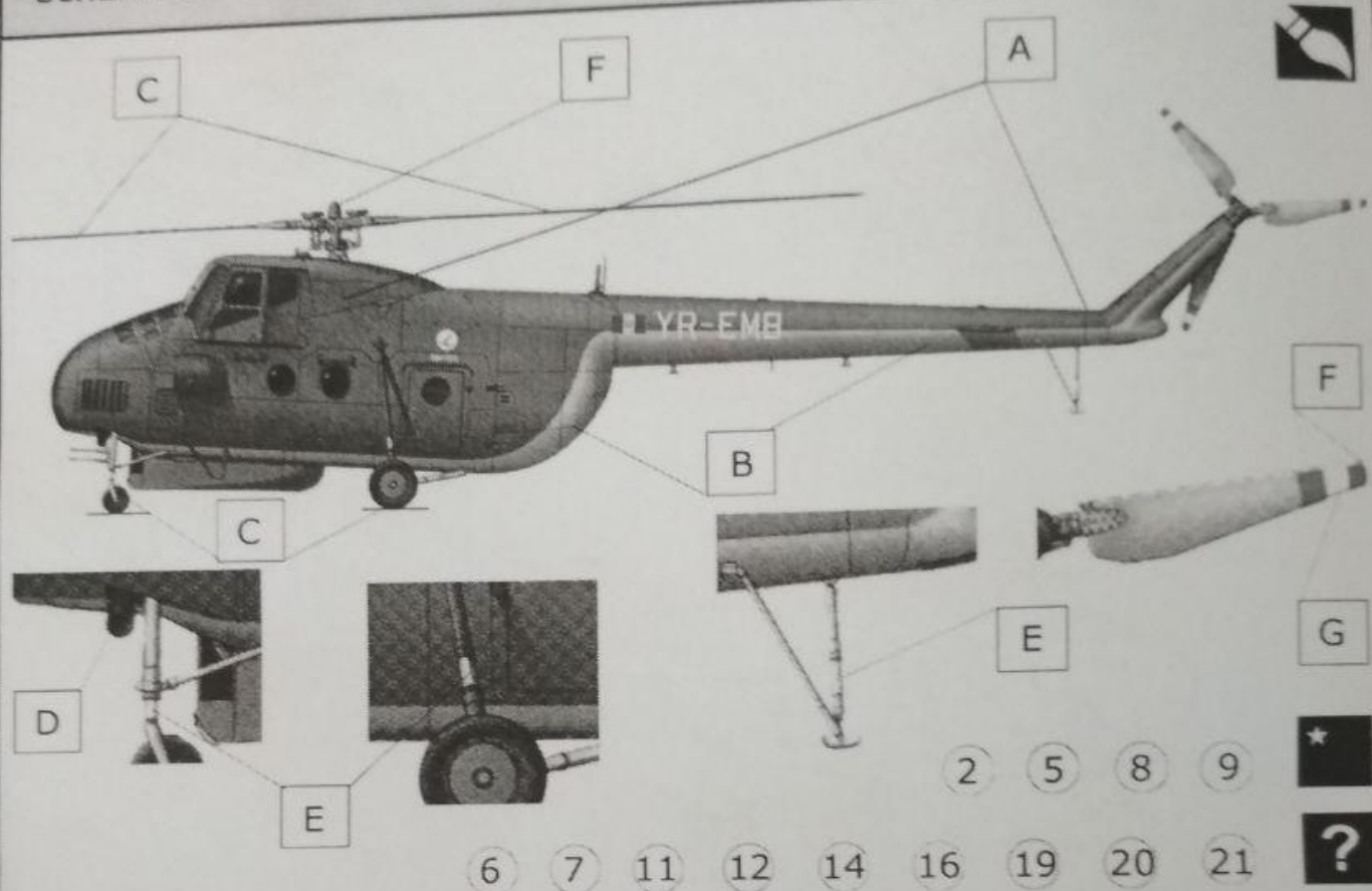

Mi-4 UR-EMB

Foto colectia Razvan Bujor



SCHEMA DE VOPSIRE și ÎNMATRICULARE / SCHEME OF COLOURING and MARKING

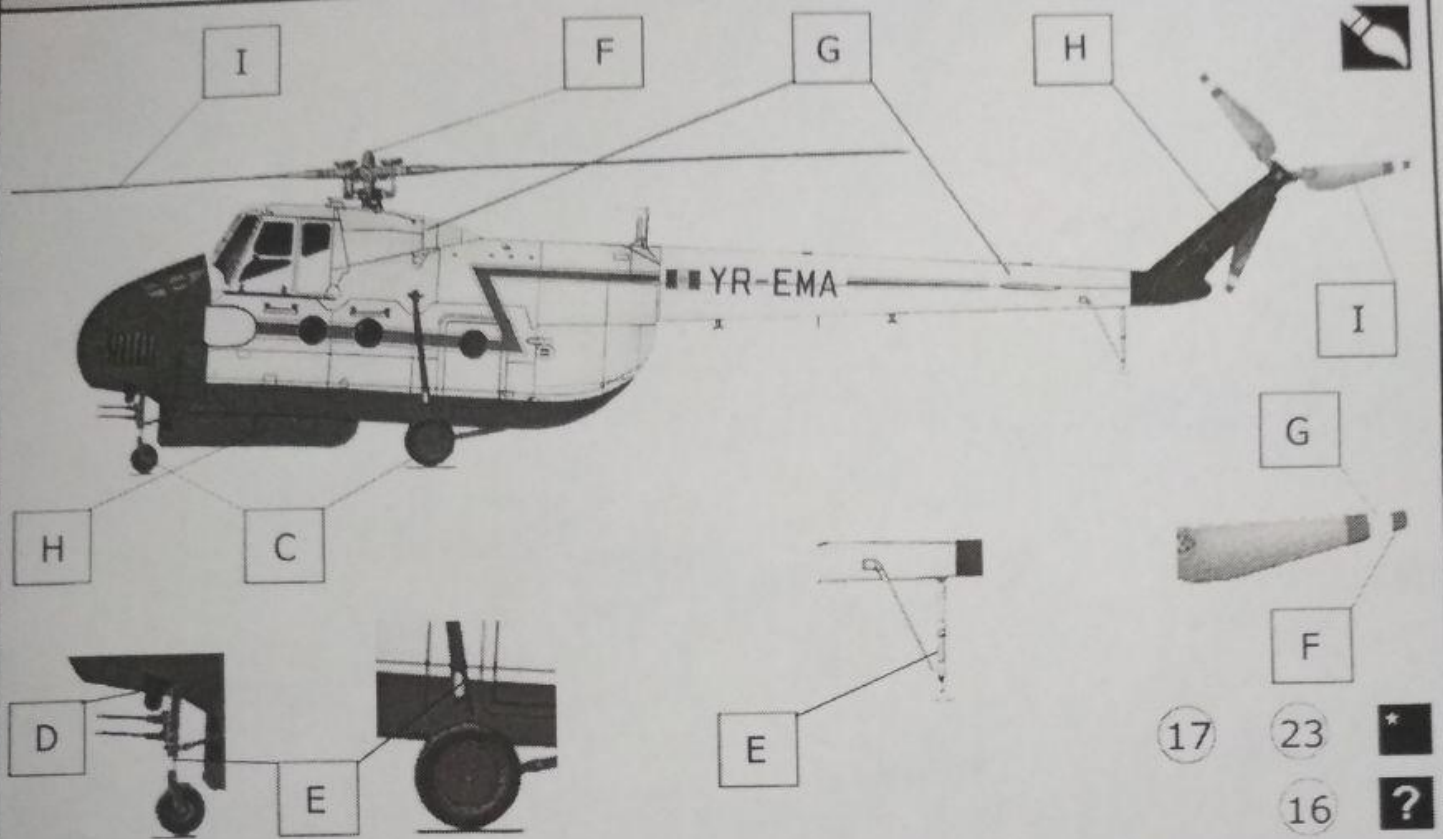

Mi-4 YR-EMA

Foto colectia Razvan Bujor



SCHEMA DE VOPSIRE și ÎNMATRICULARE / SCHEME OF COLOURING and MARKING

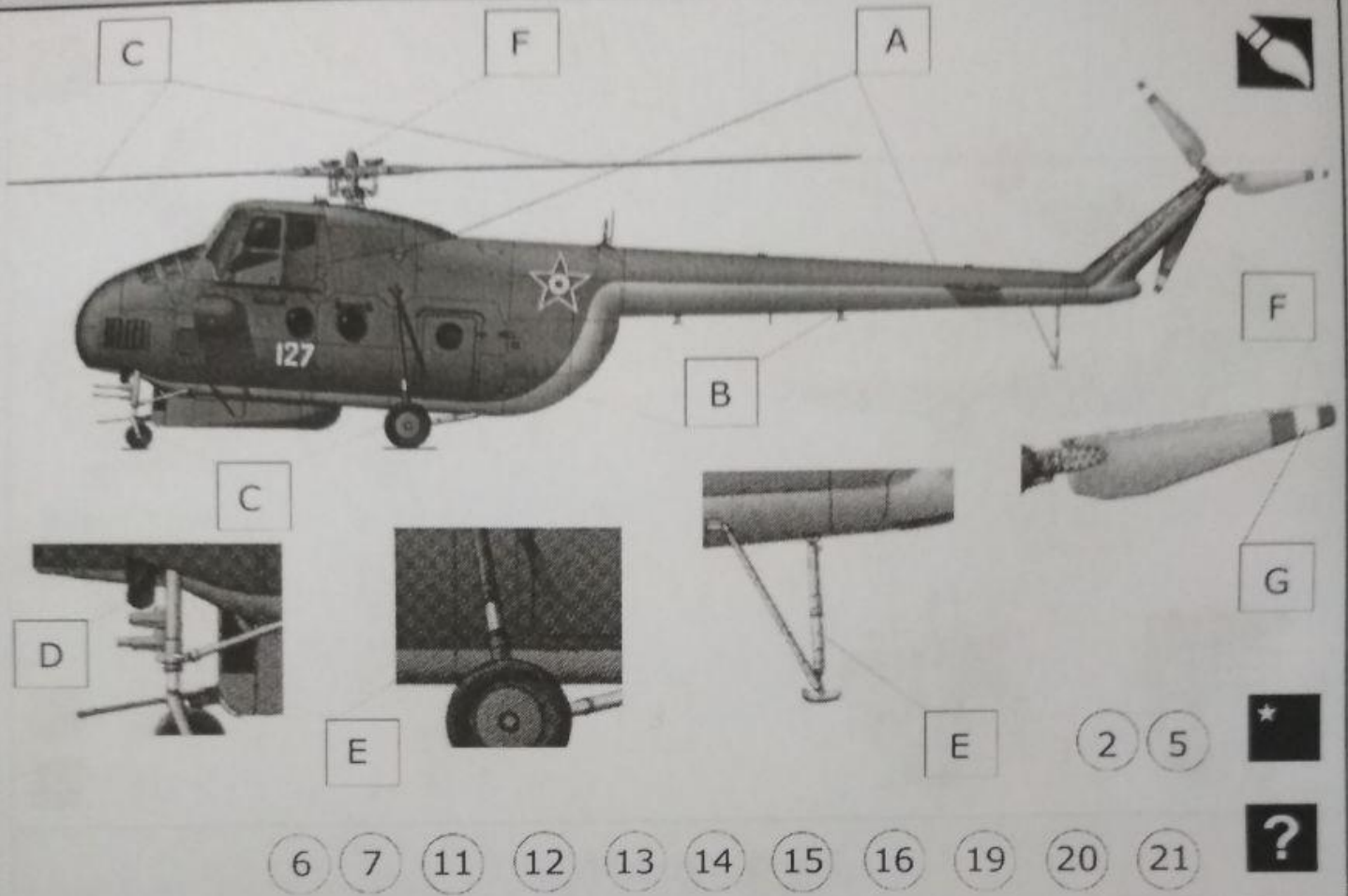

Mi-4 nr.127

