

Indianapolis Racer

KIT 0012

Monogram
quality hobby kits

0012M0200

Plastic Scale Model

1/24 SCALE

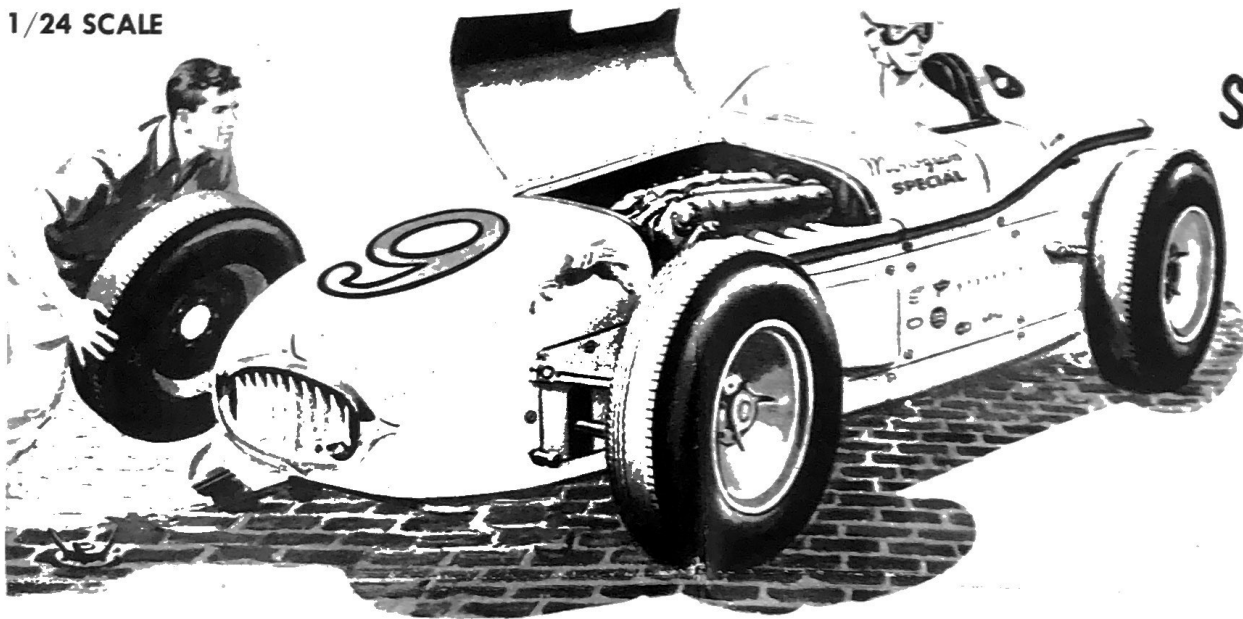

You Can
Steer It!

Full-Steering Front Wheels • Driver, Mechanic and Tool Box • Hinged Hood • Dummy Engine • Decals

AUTO RACING CLASSIC

The 500 mile automobile race, on the Speedway at Indianapolis, is the outstanding feature of all U. S. Memorial Day activities, each year. It is the oldest continuing auto racing event and leads all such races in its rich prize and furious average speeds. The Speedway course, paved mainly with brick, is known as the "Brick Yard" and is 2½ miles in length—200 turns around, or laps, for the 500 mile race.

"500" SPEEDWAY "BIG CARS"

The "big cars" raced on the Speedway at Indianapolis are specially built and cost about \$25,000. The prototype of the Monogram Plastik is 14'3½" long and overall height is 41". It can reach a speed of 170 mph. on a three-quarter mile straightaway.

Engine and drive shaft are 6" off center to the left and the driver sits low to the right. Entire underside is enclosed. The car sports only a few instruments and these are the tachometer, oil and fuel pressure gauges and a water temperature gauge.

The fuel tank holds 70 gallons and the tires last for only 60 to 70 laps—150 to 175 miles.

THE FAITHFUL, AUTHENTIC MODEL

The Monogram Plastik model is an exact scale model of a Kurtis-Kraft "big job", scaled one-half inch to the foot. As you get into the fun of assembling this fine model, you will enjoy a very special thrill because of some unusual and exclusive features such as full steering front wheels.

Other features are the hinged hood, detailed engine, instrument panel, quick-release fuel tank cap, the amazing detail of the tires, perfectly molded grill and authentic markings. All this and a realistic racing driver, pit mechanic and tool box as kit extras.

Your finished car can be displayed with the hood up and the mechanic leaning over the engine or with hood closed and mechanic leaning against the cockpit area as if talking to the driver during a fueling stop.

FINISHING COLOR SUGGESTIONS

CAR BODY, HOOD AND NOSE—Do not paint unless you want a different color. **FLAT BLACK**—Inside of grill, magneto on engine, dashboard—leave instruments unpainted, simulated leather around cockpit, seat, recess for gas cap, rim of steering wheel and tires. Tires should be painted and allowed to dry. Then carefully scrape away paint from tops of letters with a razor blade.

SILVER — Wheel hubs, engine, exhaust, front and rear axles, radius rods, torsion arms, king pins, steering knuckles, gas cap, hub caps, starter extension, front of grill bars, frame around grill, tie rod, jack posts on nose and body, piano hinge on hood, and spokes and centerpost of steering wheel.

GREEN—Toolbox.

DRIVER—Flesh face and hands, red helmet and lips, white safety belt and lower part of helmet, brown trousers, rim of goggles and goggle strap, blue shirt and black shoes.

MECHANIC—Flesh face and arms, red cap and lips, brown hair and shoes, yellow shirt, tan trousers and silver wrench in hip pocket.

READ THIS BEFORE YOU BEGIN ASSEMBLY

The Monogram Indianapolis Speedway Racer is precision molded from the finest quality polystyrene plastic. Follow the 16 assembly sketches closely and be sure to check the fit of each part before you glue it in place. Remove all small parts from the "tree" to which they are attached. Carefully trim away any excess bits of material with a sharp knife. Use plastic cement

to join the parts. Avoid getting glue on outside of surfaces. Use rubber bands where necessary to hold parts firmly together and allow glue to dry thoroughly before handling the parts. If you are going to paint your model, refer to the suggested colors and to the paragraph about painting at the bottom of this page.

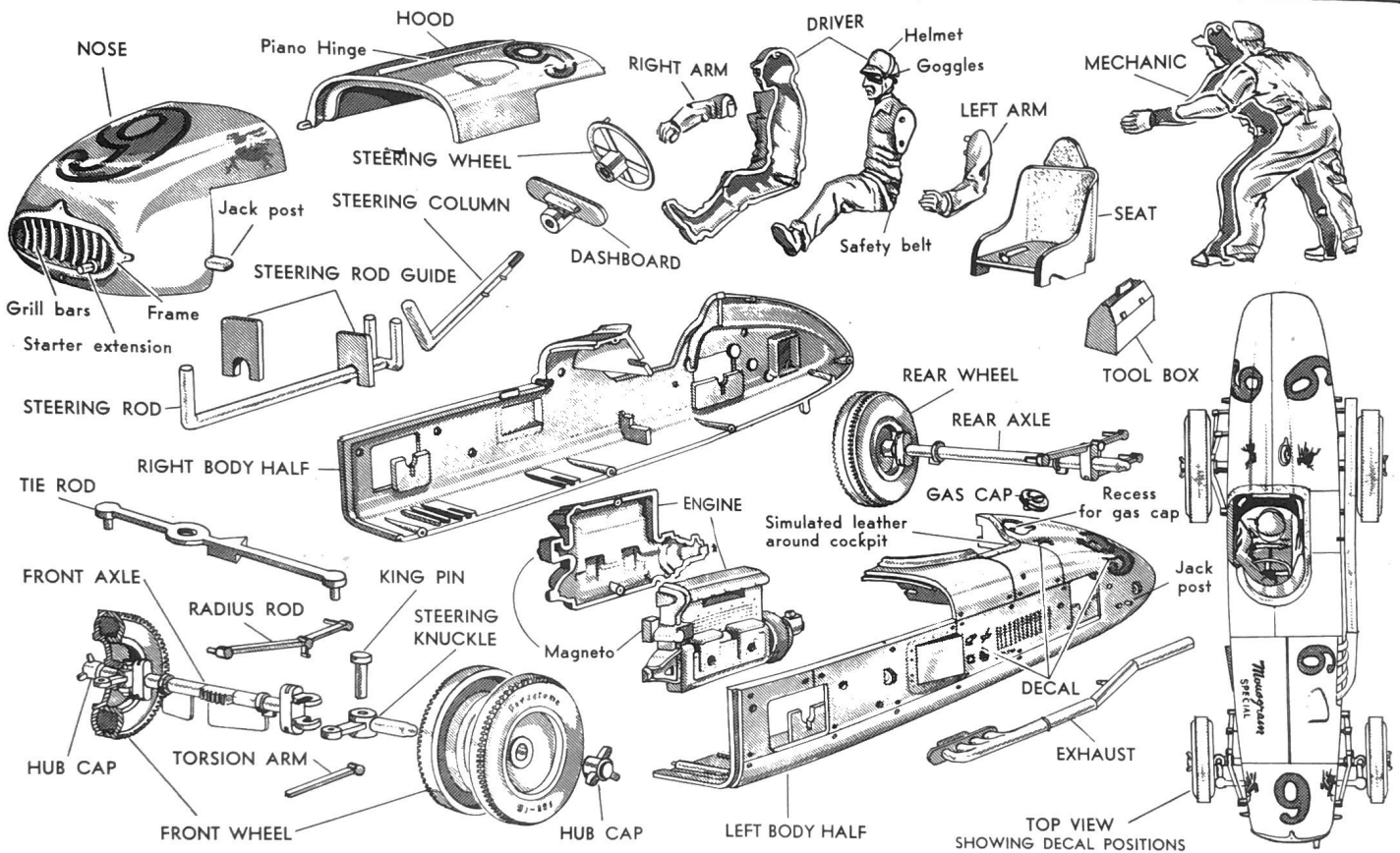
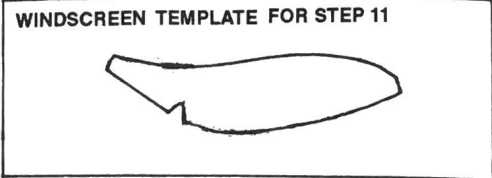

HOW TO APPLY DECALS

For best results, follow this procedure when applying decals: Cut the decal apart with scissors inside the dotted line. Work with one subject at a time. Dip it in water for a few moments until it slides easily on the paper backing. Study drawings for correct location. Slide the decal partly off of the paper backing, holding decal in place on model while sliding backing out from underneath. The decal can be shifted on the model into the correct position after applying a little water around the edges with your finger. Press out bubbles and blot with a soft rag. Allow decals to dry thoroughly overnight to avoid shifting.

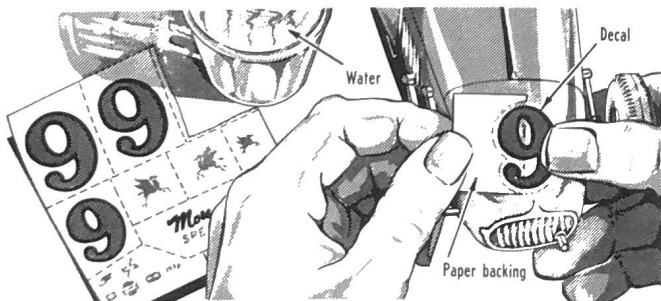

PAINTING YOUR MODEL

Your model is molded in the popular colors of the full size Indianapolis racers. If you wish, you may paint the car body, hood and nose, your favorite color. **ONLY ENAMEL OR PAINT FOR PLASTICS SHOULD BE USED.** Do not use lacquer or model dope as this may cause crazing of the surface. Apply with a small soft brush and allow sufficient time for paint to dry thoroughly before handling parts. All parts to be painted with the exception of the wheels, engine, mechanic and driver should be painted before they are assembled. Paint all tiny parts while they are attached to the tree for ease of handling.

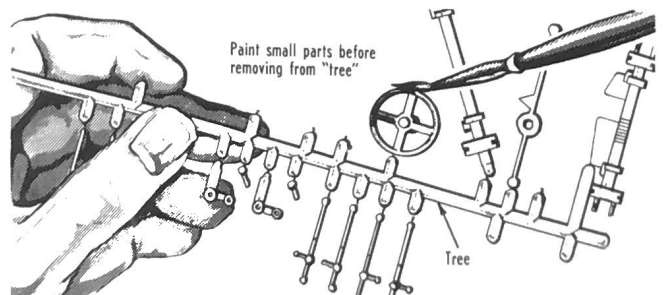

RACE CAR ASSEMBLY DIRECTIONS

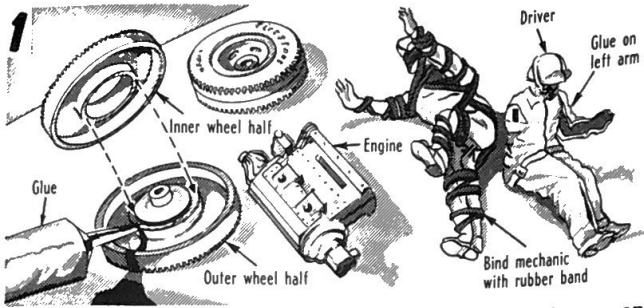

1 Glue together wheel halves, engine, driver with left arm only, and mechanic. Apply the glue sparingly. Bind mechanic with rubber bands to press halves together until glue dries. If you are going to paint your car refer to colors on page 1 and paint parts now before beginning assembly.

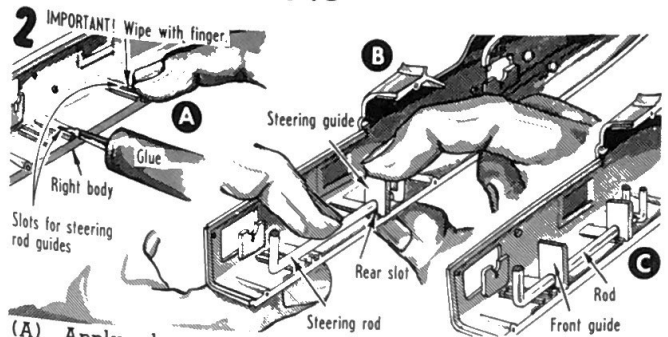

2 **IMPORTANT!** Wipe with finger. (A) Apply glue sparingly into two slots in right body. **IMPORTANT!** Wipe finger across top of slots to remove any excess glue that would get onto steering rod. (B) Hold steering rod in place and insert steering guide over rod and into rear slot. Note: Steering guide overhangs edge of body. (C) Insert front guide. Carefully slide rod back and forth to make certain it is not glued to body.

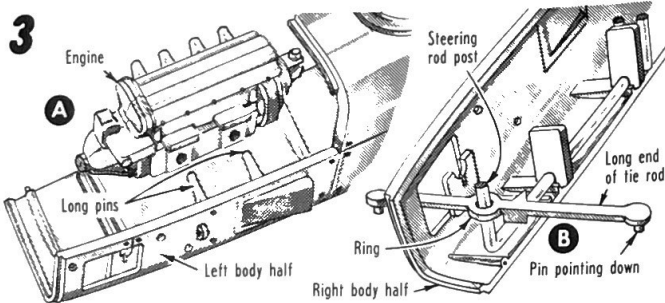

3 (A) Put a drop of glue into each hole in side of engine. The two holes in engine fit over long pins inside of left body half. Press engine tightly onto pins. (B) Slip ring on the rod over post of steering rod with long end overhanging as shown in sketch and with pins on each end pointing **down** as shown.

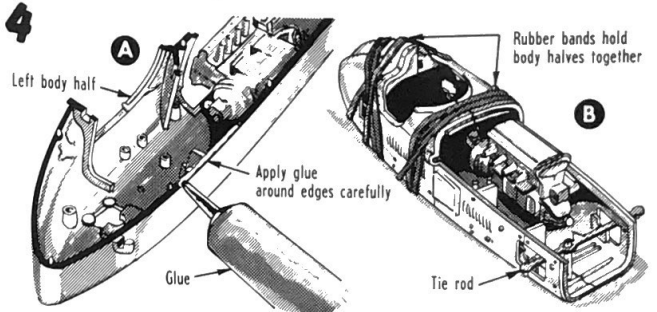

4 (A) Apply glue carefully to edges of left body half as shown by heavy black line. (B) Join the two body halves making sure that tie rod goes through square opening in left body half. Wrap body with rubber bands as shown for a good glue joint. Remove rubber bands when glue is dry.

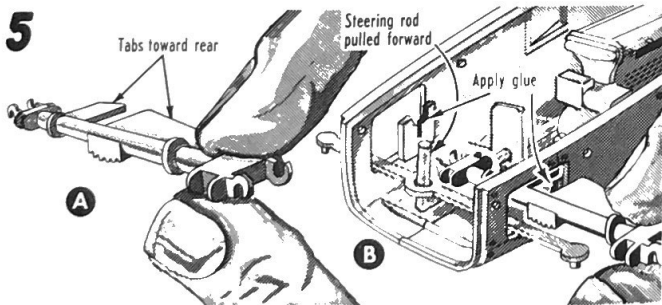

5 Fit front axle into place as follows: (A) Hold front axle as shown with two large tabs toward the rear and the ratchet teeth toward the bottom. (B) Pull steering rod forward as far as it will go and insert axle through large openings in sides of body at front. Then apply glue to half round openings and between ribs on body bottom and put axle in place as shown in next step.

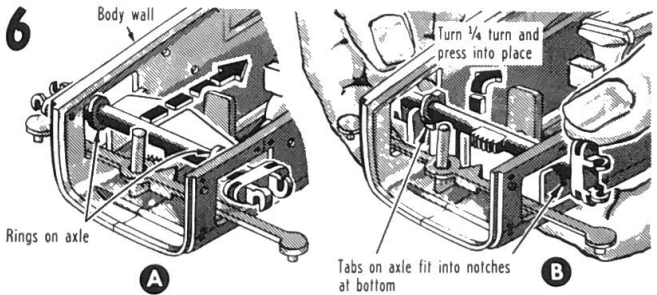

6 (A) With tabs towards rear as shown, push entire axle rearward. Two rings on axle must be between body wall. (B) Turn axle $\frac{1}{4}$ turn as shown and press it down into half round openings with large tabs facing downward and fitting between ribs on body bottom. Install rear axle making sure that small tabs on rings are pointing down into notches.

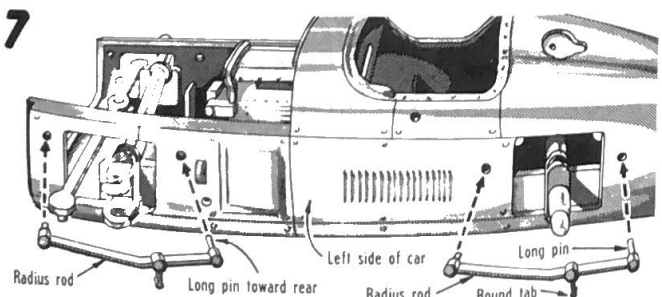

7 **BEFORE** gluing, determine proper location of radius rods on left side of car as follows: Hold them **EXACTLY** as shown above with the long pin towards the rear of car and with the round tab near center pointing down. There are two for the left side and two for the right side so be sure you have the correct pair.

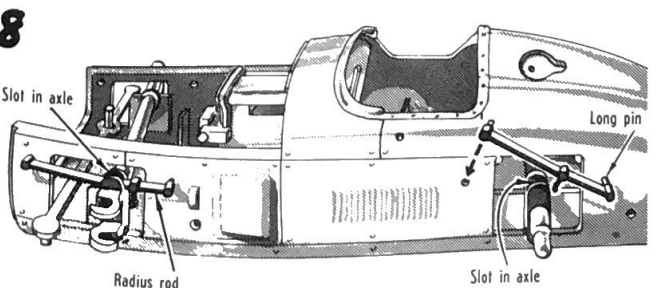

8 Apply glue into holes in body and into slots in top of axle. Insert long pin on radius rod into rear hole first, then put part at center into slot in axle and push pin at front into other hole in body. Install radius rods on right side of body in the same manner.

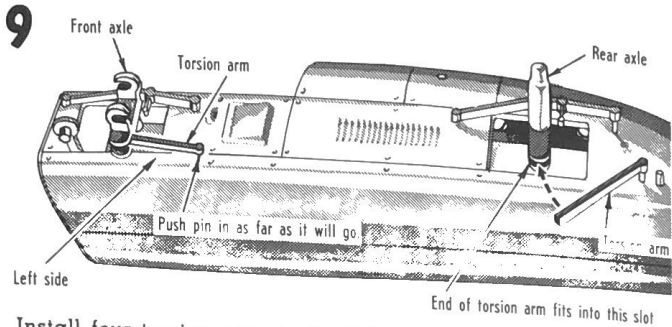

Install four torsion arms in the following manner. Put glue into holes in body and slots at bottom of axles on left side. Press pins on torsion arms into holes in body and end of arms into slots at bottom of axles. Attach torsion arms on right side in the same manner.

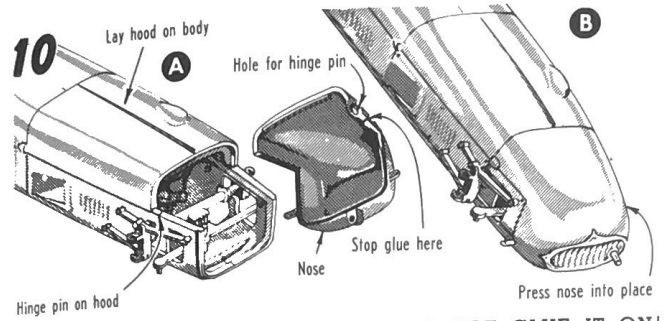

(A) Lay hood in position on body. DO NOT GLUE IT ON! Apply glue to edges of nose as indicated by black line in sketch above. (B) Attach nose to front of body making sure that hinge pin on front of hood goes into hole at rear of nose. Keep glue off of hood so it can be opened.

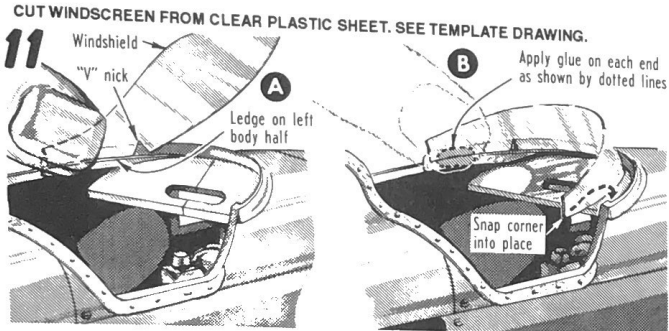

(A) Place windshield on ledge inside of left side of body with V nick toward bottom, and hold with thumb of left hand as shown. (B) Curl other end of windshield to inside of body with right hand and press corner forward until it snaps into position. Apply glue to ends of windshield.

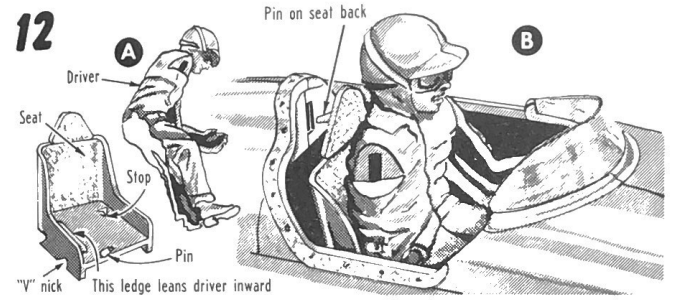

(A) Glue driver to seat. IMPORTANT! Pin on front of seat goes between legs and the left side of body must rest against the stop near rear of seat. Allow to dry. (B) Put glue into "V" nicks in bottom of bucket seat and onto pin on seat back and insert driver and seat assembly into cockpit.

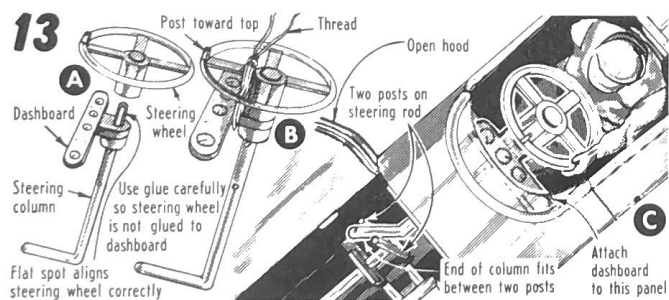

(A) Insert steering column in dashboard. Put a tiny drop of glue into hole in steering wheel and press it on. (B) To keep dashboard from twisting while installing it, tie on a 12" length of thread as shown. (C) Apply glue to back of dashboard and slip assembly into place with end between two posts on steering rod. Cut thread free when glue dries.

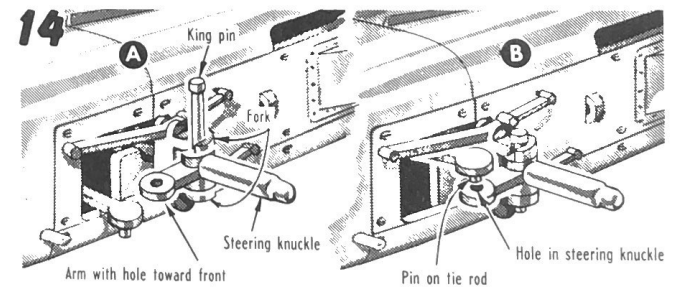

(A) Insert steering knuckle into fork in front axle so that arm with hole is toward front. Put king pin through holes in fork and steering knuckle. Glue bottom of king pin to fork only. CAUTION! Do not get glue on steering knuckle. Install on other side also. (B) Insert pins on tie rod into holes on steering knuckles. DO NOT USE GLUE.

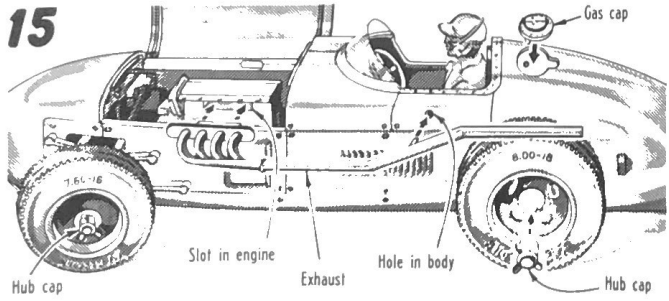

Put glue into slot in engine and hole in left side of body and attach exhaust. Glue on gas cap. Slip wheels on with lettering to the outside. Large wheels go on rear axle. Put a tiny drop of glue into holes in hub caps and press on ends of axles. Make sure wheels spin freely.

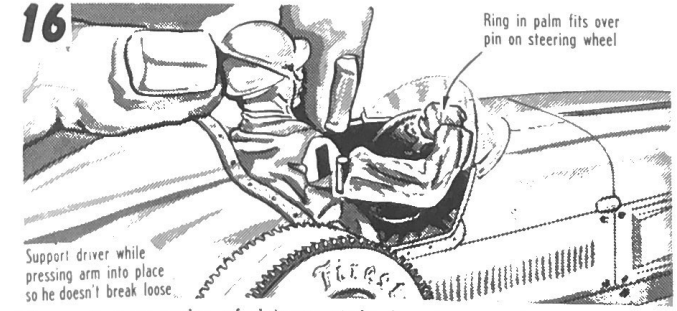

Place ring in palm of drivers right hand over pin on steering wheel. DO NOT GLUE. Now press and snap post on arm into slot in shoulder. To steer front wheels, hold right arm of driver between your thumb and forefinger and move from side to side. Finally apply decals. See instructions "How to Apply Decals" on page 2.