

EagleCals
EC#26

1/72
 1/48

Bf 109 G-108

Augsburg's Last Eagles

eagle
EDITIONS LTD.

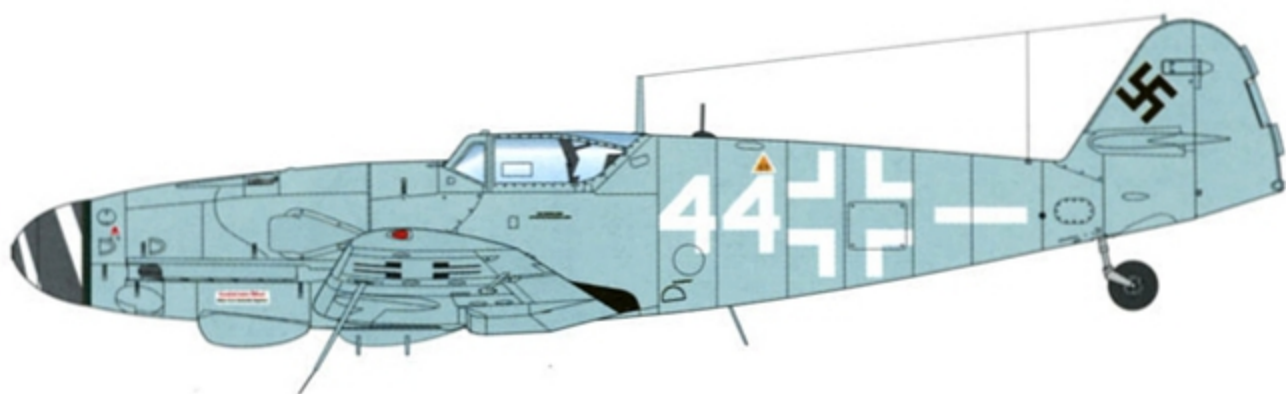
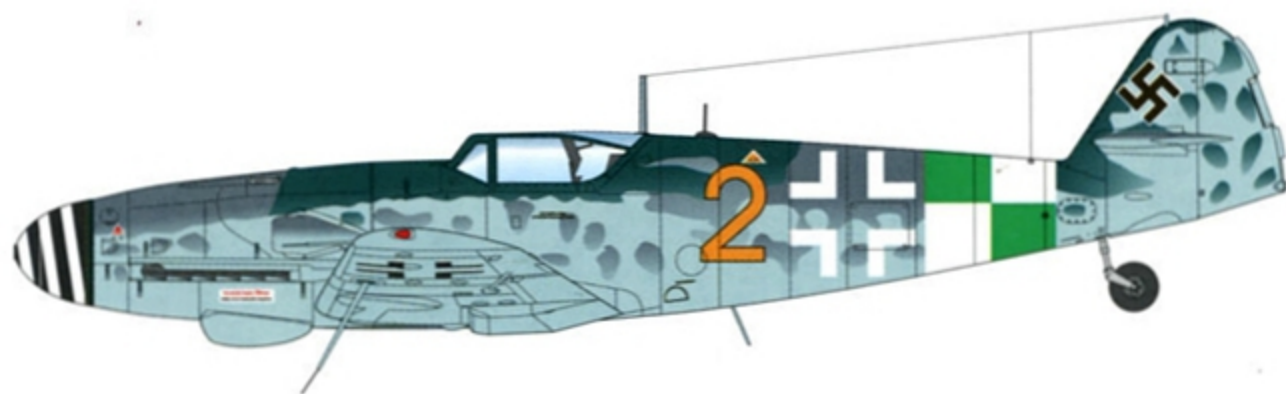
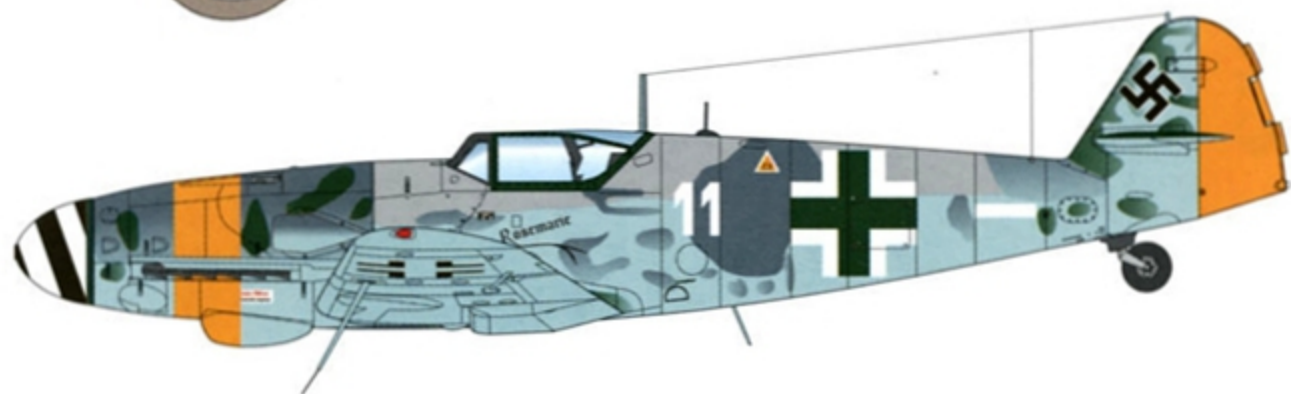

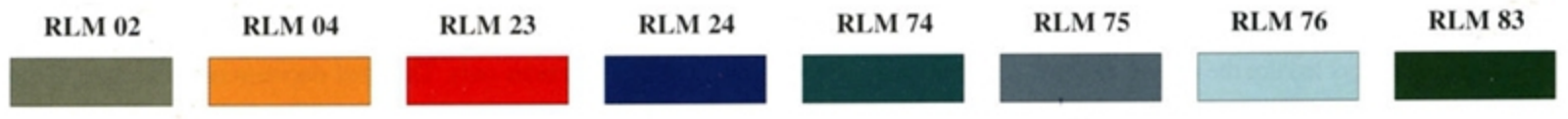
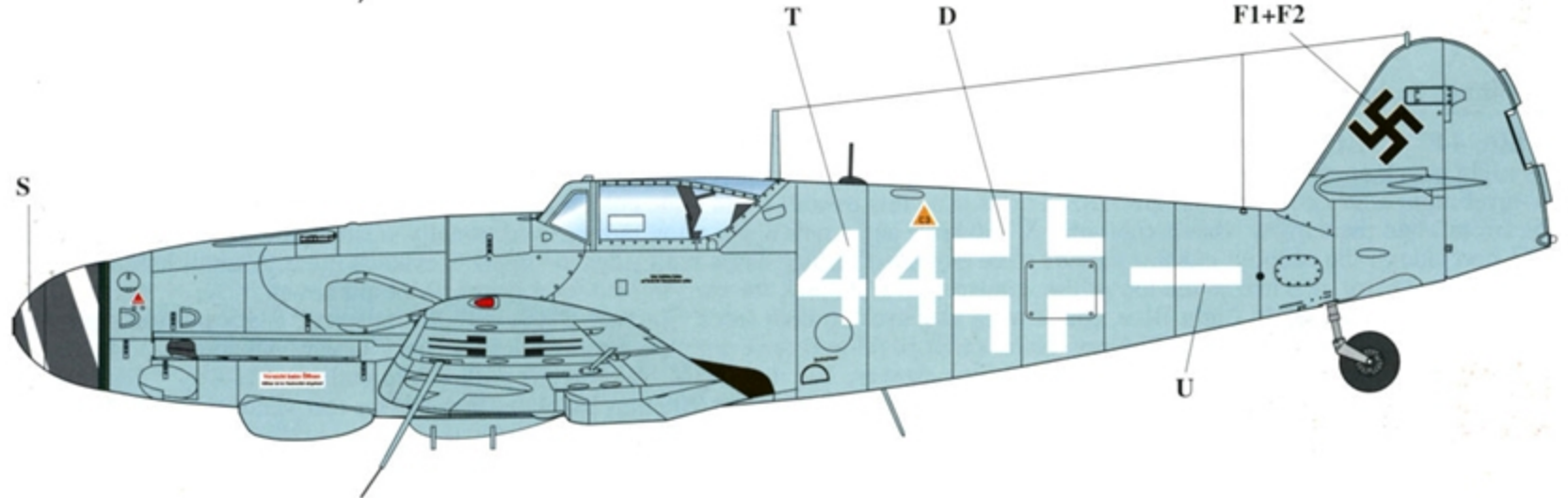
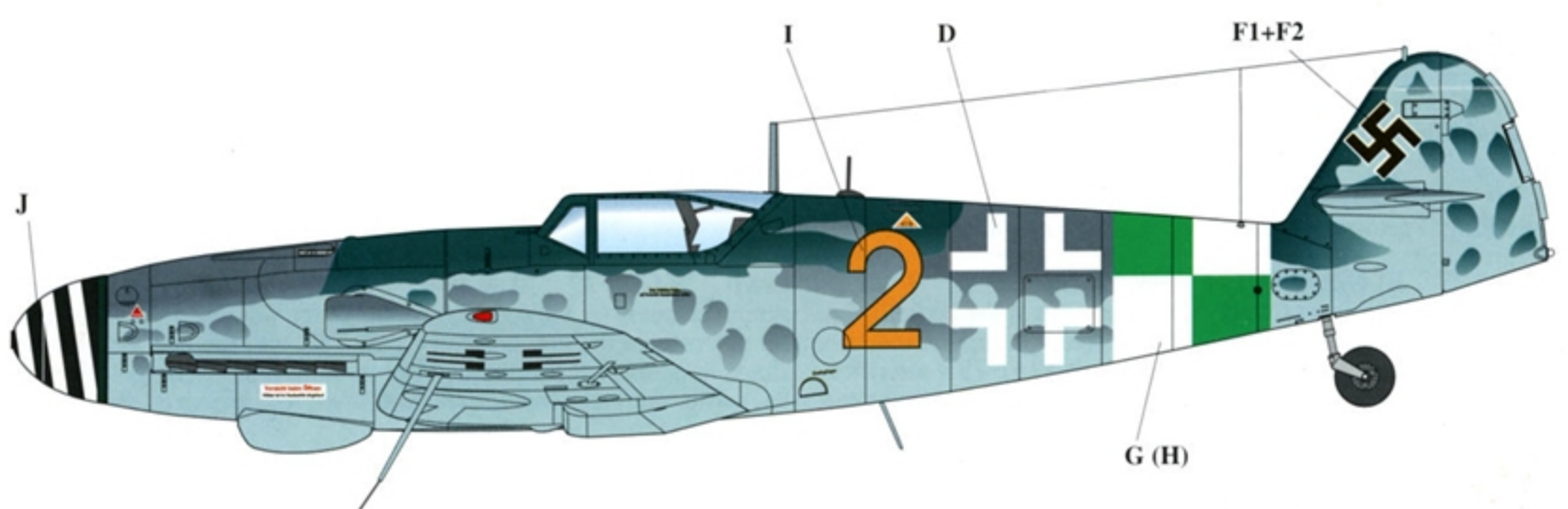
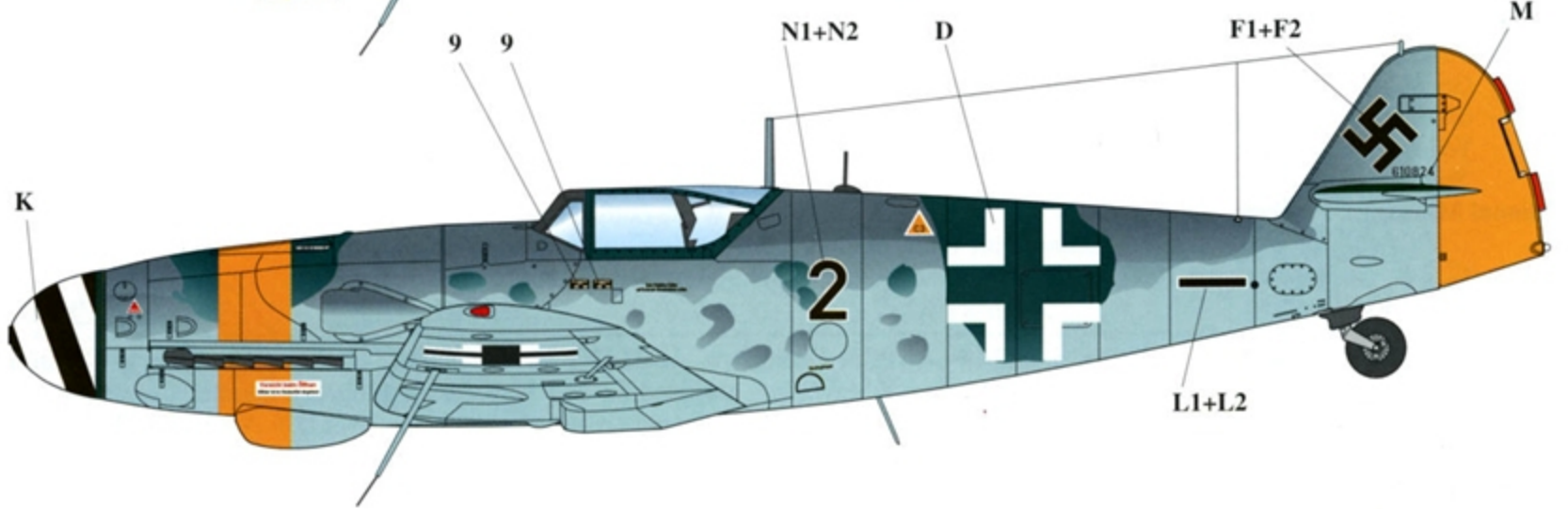
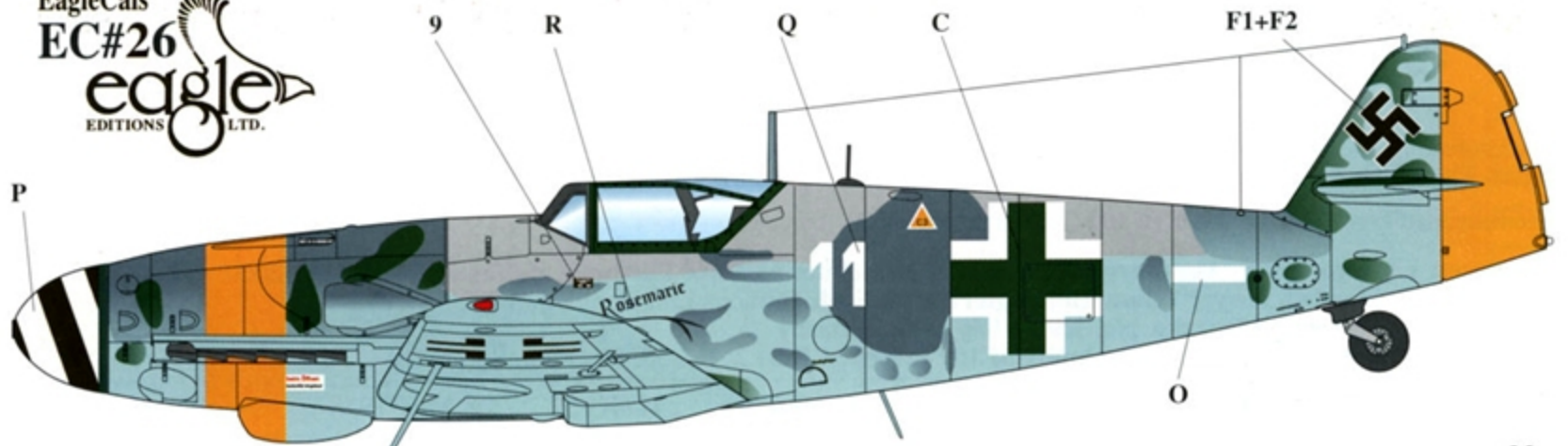

EagleCals #26

Bf 109 G-10s Augsburg's Last Eagles

Four interesting and colorful Bf 109 G-10s were selected for this sheet, three of which are based on Brett Green's book *Augsburg's Last Eagles*, *EagleFiles #3* and one, "Black 2" based on the Bf 109 in "*Yellow 10*" *EagleFiles #2*.

Recommended kits: 1/48 Hasegawa Bf 109 G-10 or the Revell Bf 109 G-10

References: 1. Green, Brett; *Augsburg's Last Eagles*, *EagleFiles #3* Eagle Editions Ltd. Hamilton MT USA 2000
2. Crandall, Jerry; "*Yellow 10*" *EagleFiles #2* Eagle Editions Ltd. Hamilton MT USA 1999
3. *Flugzeug Magazine* No. 3 June/July 1987 Germany
4. Beaman, John; *Messerschmitt Bf 109 in Action Part 2*, No. 57, Squadron Signal USA

"White 11" Bf 109 G-10 W. Nr. Unknown Pilot Unknown II./JG 52 8 May 1945 Neubiberg, Germany

One of a large group of aircraft that flew in and surrendered at Neubiberg, on 8 May 1945. Unusual patchy color scheme makes it difficult to accurately interpret the camouflage color combinations. Typical small tactical numbers of II./JG 52. All antennas intact.

Colors: Undersurfaces; 76 Light Blue; Upper surfaces, Light Gray (no RLM designation) along the fuselage spine. Patches of 75 Gray-Violet segments and mottling on fuselage. Cowling appears to 75 overall, possibly a replacement. 83 Dark Green mottling on cowling. Upper wings and horizontal stabilizer 75 Gray-Violet and 83 Dark Green or the 75/74 combination also possible. 04 Yellow cowl stripe and rudder indicating Luftflotte 4 aircraft.

Spinner: Black with White spiral. Prop Blades: 70 Black-Green Canopy and windscreen framing 66 Dark Gray.

National Markings: Fuselage; 900 mm Black "C" or 83 Dark Green with White outline cross "D"

300 mm Black Hakenkreuz with White outline.

Wings; upper 1000 mm White outline crosses; lower 900 mm Black outline crosses.

Stencilling: Factory standard.

Reference: #1

"Black 2" Bf 109 G-10/U4 W.Nr. 610824* Pilot Unknown II./JG 52 8 May 1945 Neubiberg, Germany

Another surrendered aircraft by II./JG 52 at Neubiberg on 8 May 1945, assigned T2-124 Technical Intelligence number, one of three G-10s brought to US for evaluations located for years in Atlanta, Georgia, ultimately restored and presently in U.S. Air Force Museum collection at Dayton, Ohio. Large 660 mm X 190 mm wheels and corresponding larger bulges on upper wing. Antenna mast mounted on canopy. For additional information on this aircraft, see reference Number 2. *Werknummer is based on testimonial given by Vintage Aircraft Restoration Company who restored this aircraft.

Colors: Undersurfaces; 76 Light Blue. Uppersurfaces; 75 Gray-Violet/74 Gray-Green. Wide 04 Yellow band around cowling and 04 Yellow rudder as ordered by Luftflotte 4.

Canopy and windscreen framing 66 Black-Gray. Spinner: Black with White Spiral (provisional) Prop Blades: 70 Black-Green.

National Markings: Fuselage; 900 mm White crosses filled with 74 Gray-Green

300 mm Black Hakenkreuz with White outline, 23 Red trim tabs (speculative).

Wings: upper 1000 mm White outline crosses; lower 900 mm Black outline crosses (provisional).

Stencilling: Factory standard. Two factory data plates on fuselage.

Reference: #2

"Yellow 2" Bf 109 G-10/U4 W.Nr. Unknown Pilot Unknown KG(J) 27 May 1945 Kaufbeuren Allgäu, Germany

This G-10 fuselage was found on a scrap heap at the airfield Kaufbeuren Germany in May 1945. A color photo and profile was published in *Flugzeug Magazine* June/July 1987 issue. A computer enhancement determined the cowling to be type 110 with the port side incorporating the vertical panel line (see *EagleCals #16*). This aircraft has characteristics of the 150xxx -158xxx werknummer range. Since this known photo doesn't show all of the machine, along with the tail wheel strut, there is some speculation involved; however, the fuselage colors are vividly shown.

Colors: Undersurfaces; 76 Light Blue. Uppersurfaces; 75 Gray-Violet/74 Gray-Green.

Spinner: Black/White spiral (speculative) Prop blades: 70 Black-Green.

Wide Green/White checkered fuselage band assigned to KG (J) 27. All antennas intact (speculative).

National Markings: Fuselage; 900 mm White outline crosses. 300 mm Black Hakenkreuz with White outline

Wings: upper 1000 mm White outline crosses, lower probably 900 mm Black outline crosses

Stencilling: Probably factory standard

Reference: #1, #3

"White 44" Bf 109 G-10 W. Nr. Unknown (possibly 130342) II./NJG 11 May 1945 Fassburg, Germany

This night attack aircraft was found with "White 43" and is very similar to it. Converted in October 1944 from 109 G-6 airframes for low-level night attack roles. Other specialized units used this overall Light Blue color scheme for higher altitude cover protection duties. This aircraft had the narrow wheels (660 mm X 160 mm) and small upper wing bulges. Additionally, a small sliding window was added to the port side of the canopy; exhaust shields were extended further down both sides to suppress exhaust glare. A small half-moon external rear view mirror attached to the top of the windscreen. ETC rack for carrying external stores. Pilot unknown.

Colors: Overall scheme; 76 Light Blue, Black wing root area on both sides. Spinner: Black with White spiral, Black portion crudely overpainted with probably 75 Gray-Violet or RLM 02 to reduce contrast. Prop blades 70 Black-Green. All antennas intact.

National Markings: Fuselage: 900 mm White outline crosses; 300 mm Black Hakenkreuz with White outline

Wings: Upper 1000 mm White outline crosses, lower 900 mm Black outline crosses (provisional).

Stencilling: Probably factory standard, possibly much is overpainted.

Reference: #1, #4

© 2001 Eagle Editions Ltd. All images/photos copyrighted by
Eagle Editions Ltd. P.O. Box 580 Hamilton MT 59840 www.eagle-editions.com
1-800-255-1830 orders (406) 375-9270 Fax or (406) 363-5415 office

No copies may be reproduced without written consent from publisher Eagle Editions Ltd., and Artist Jerry Crandall

The color schemes depicted are the artist's interpretations of the available photographic references only. The final decision resides with the modeler.

NOTE: Stencil diagram drawings are representational only. Check your references for the specific details and differences between variants.

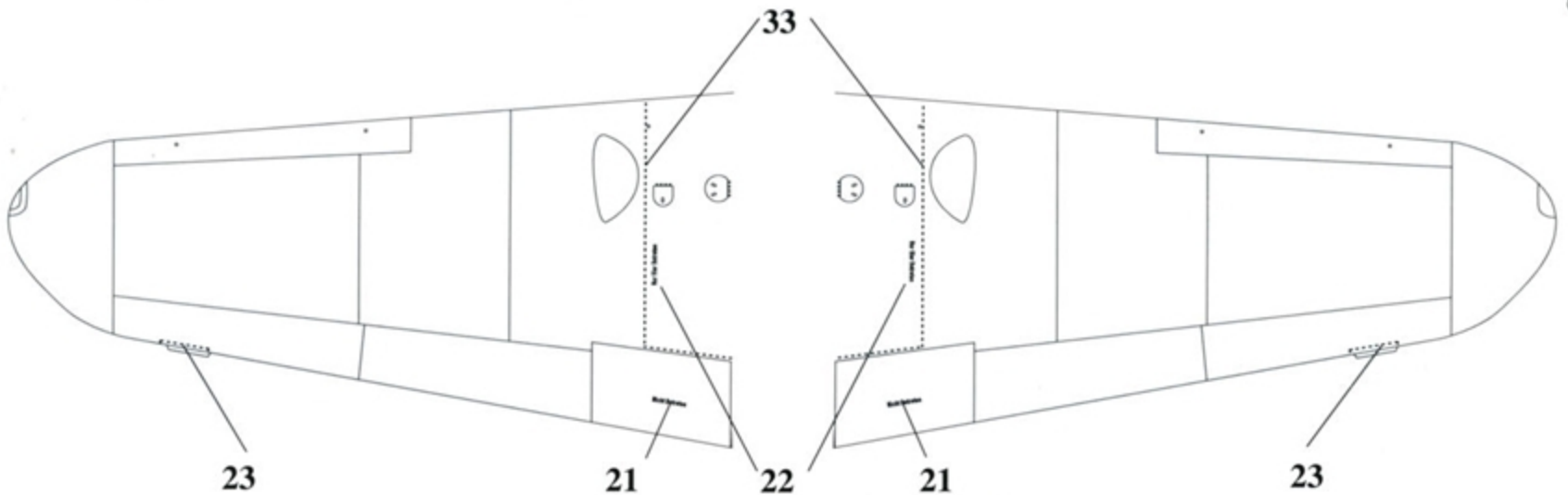
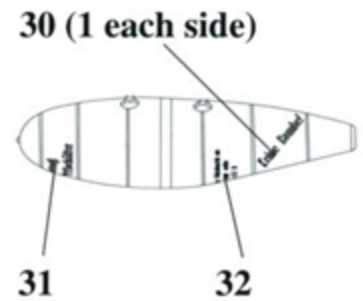
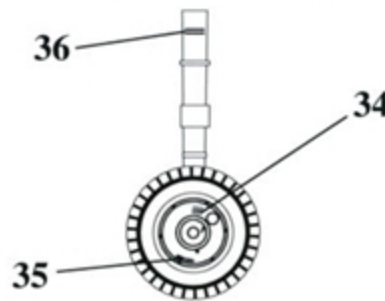
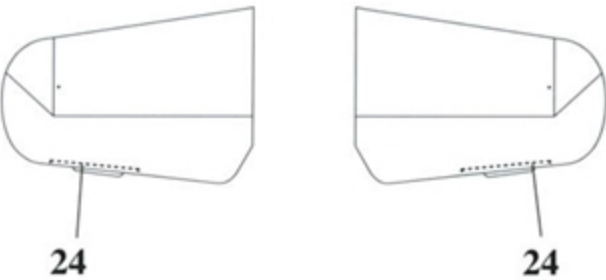
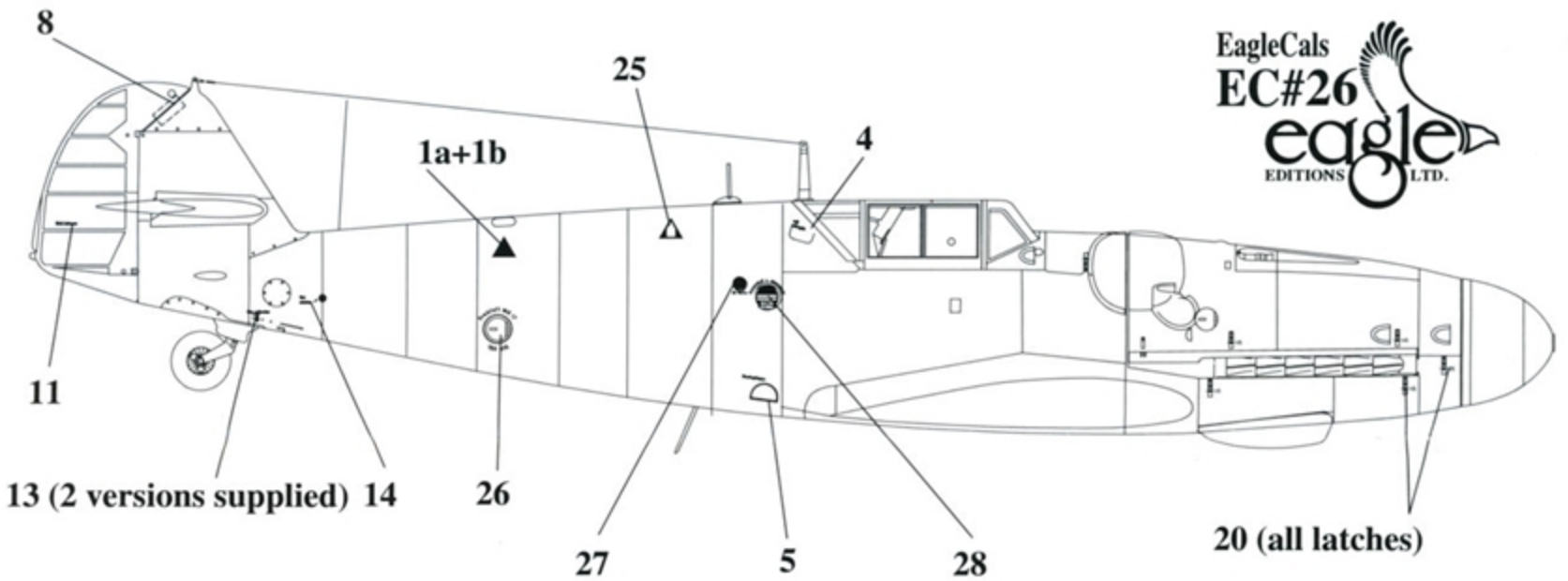
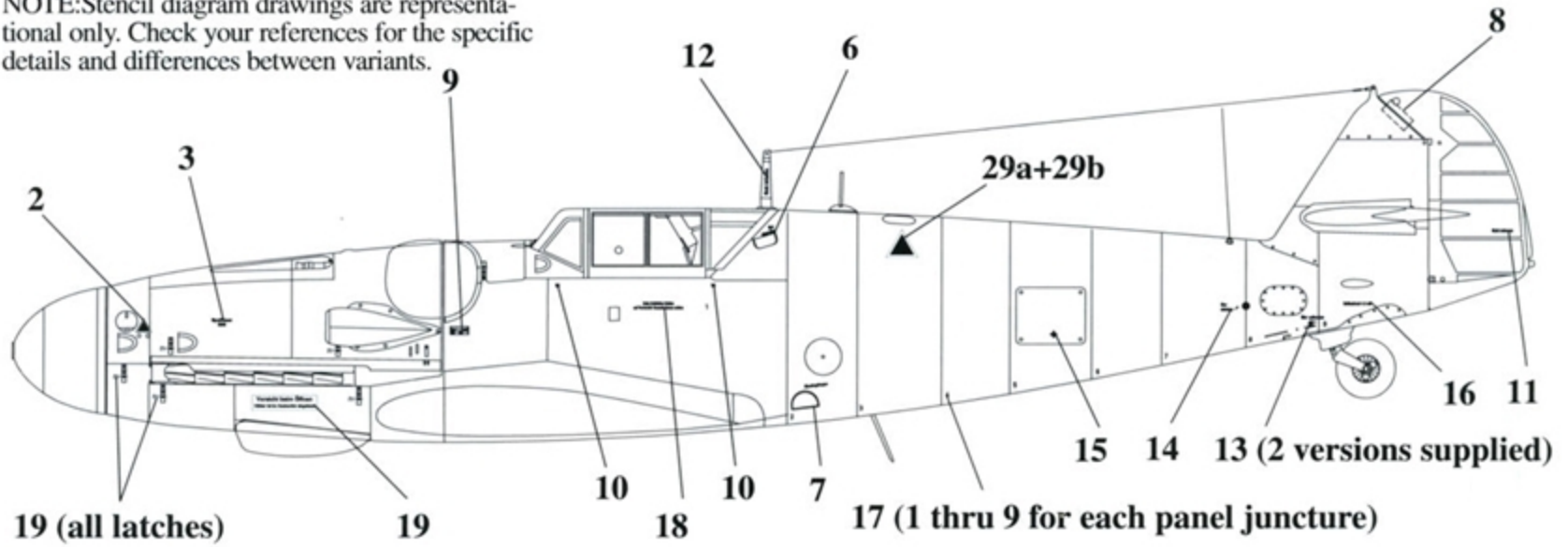

White 11

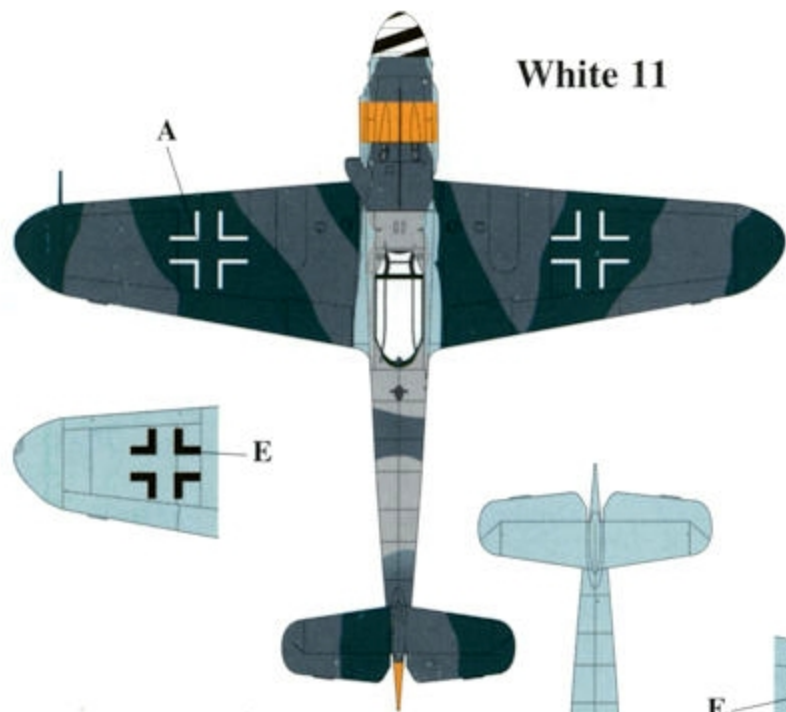

Yellow 2

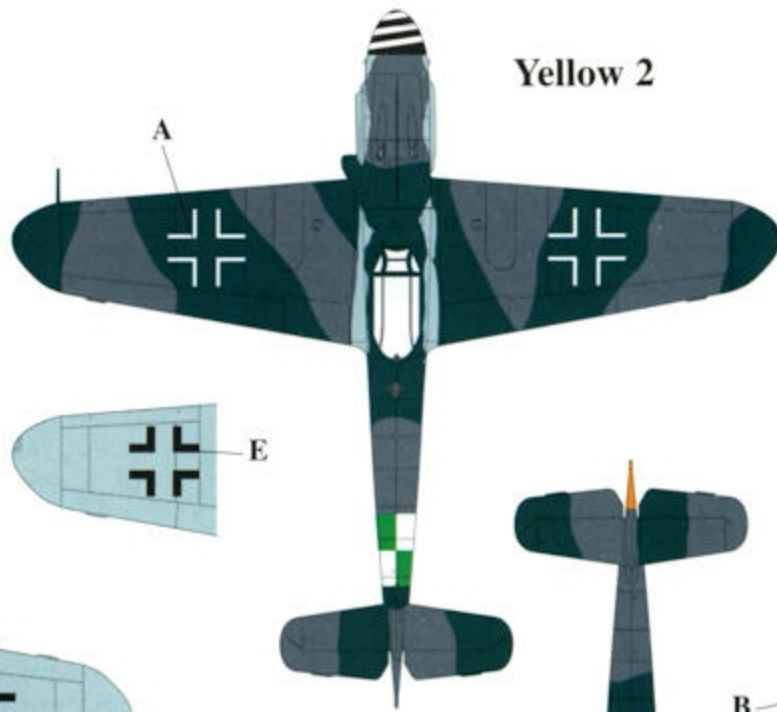

E

B

A

A

White 44

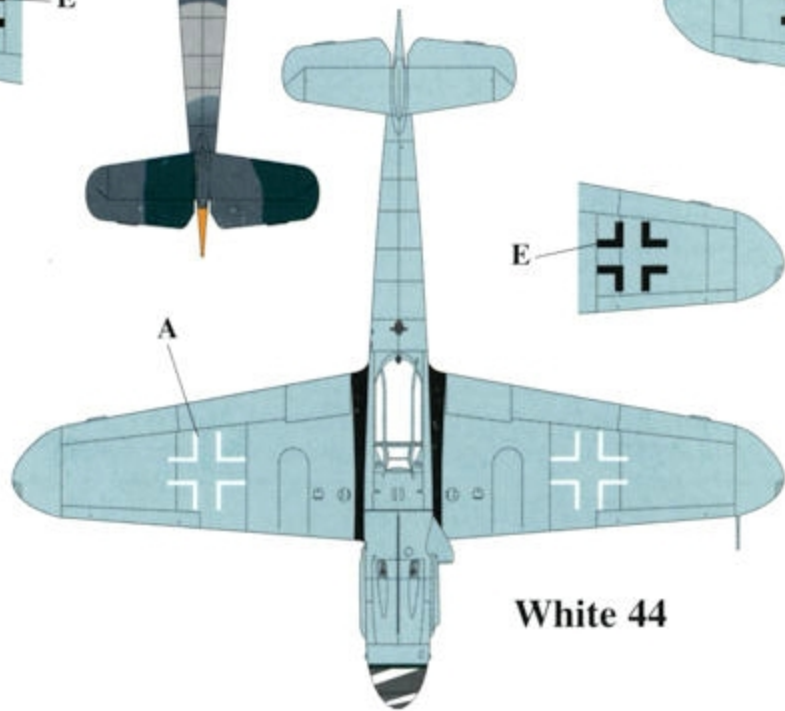

Black 2

