

72-620

# DH-112 Venom Mk.4

## Suez Crisis



AccsGB are proud to present to your attention the model kit of DeHavilland DH.112 Venom FB Mk.IV.

DH.112 Venom FB Mk.IV was a further development of Venom FB Mk.I which introduced a more powerful DH 105 Ghost engine along with many other refinements and modifications. It featured a Martin Baker Mark 1F ejection seat, power boosted control surfaces, air conditioning in the cockpit etc. It also received enlarged and "squared" tail fins to improve its handling characteristics.

150 of Venom FB Mk.IVs were built with a number of earlier Mk.Is upgraded to Mk.IV standard. Switzerland bought the license and produced over 160 airframes and engines. Many of the Swiss airframes had unusual modifications and improvements.

FB Mk. IVs served in all corners of British Empire in the 50s and was retired from RAF in 1962. The type saw combat use during Suez Crisis, Malayan Emergency and Aden Emergency. During Malayan conflict a number of Venom Mk.IVs were loaned and used by RNZAF and were operated by #14 Squadron of RNZAF. The other prolific user of Venoms was Swiss Air Force which with many upgrades and modifications used the type until 1983.

Thank you for buying this kit from us and hope it will find its proper place in your collection of jet fighters.

Acknowledgments: This kit would not be possible without kind support from Mr. Gary Hatcher and SAM team (UK), Mr. Paul Lucas (UK), Mr. Mel Bromley of SGM Models (deceased) and Sergei Shiyak aka Aarvark (Donetsk, UA). We hugely appreciate their knowledge and kind contributions.

**DISCLAIMER:** Please note this kit is not a toy, so supervision and assistance will be required if younger modelers build this kit.

Also, please remember - building a kit is supposed to be fun. When it stops being fun - STOP! You can always return to building the kit later.

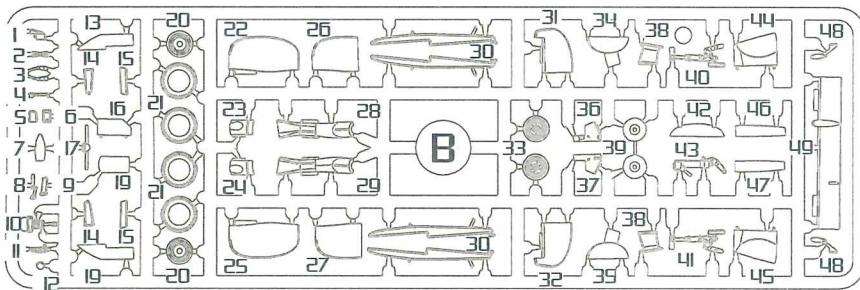
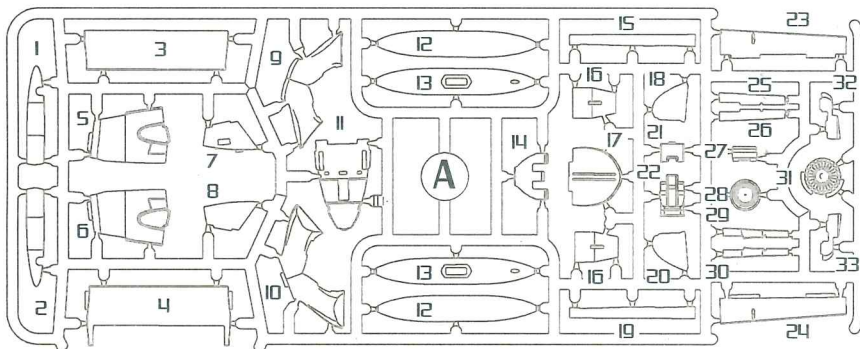

### Special Symbols



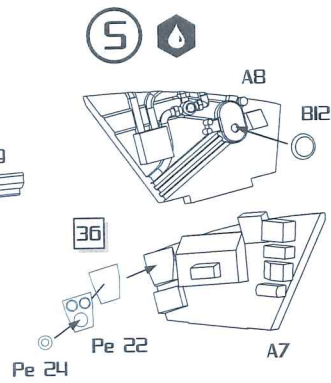
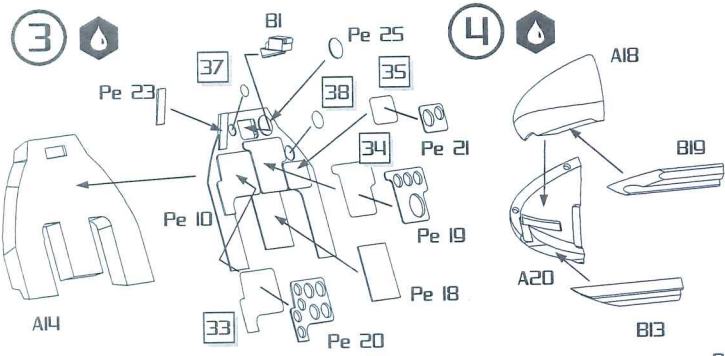
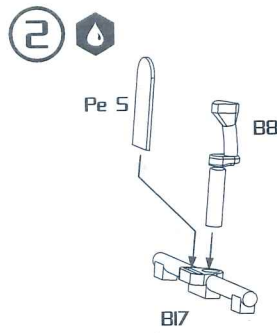
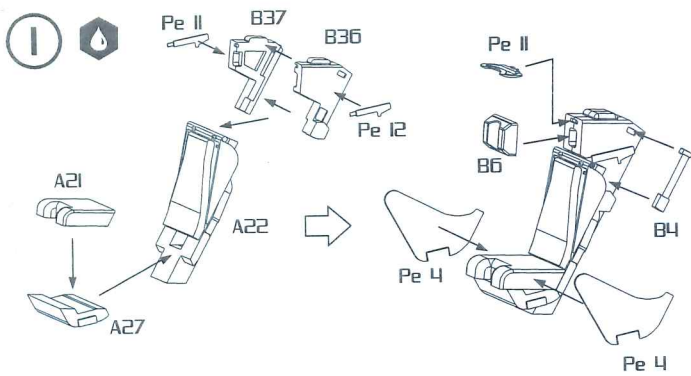
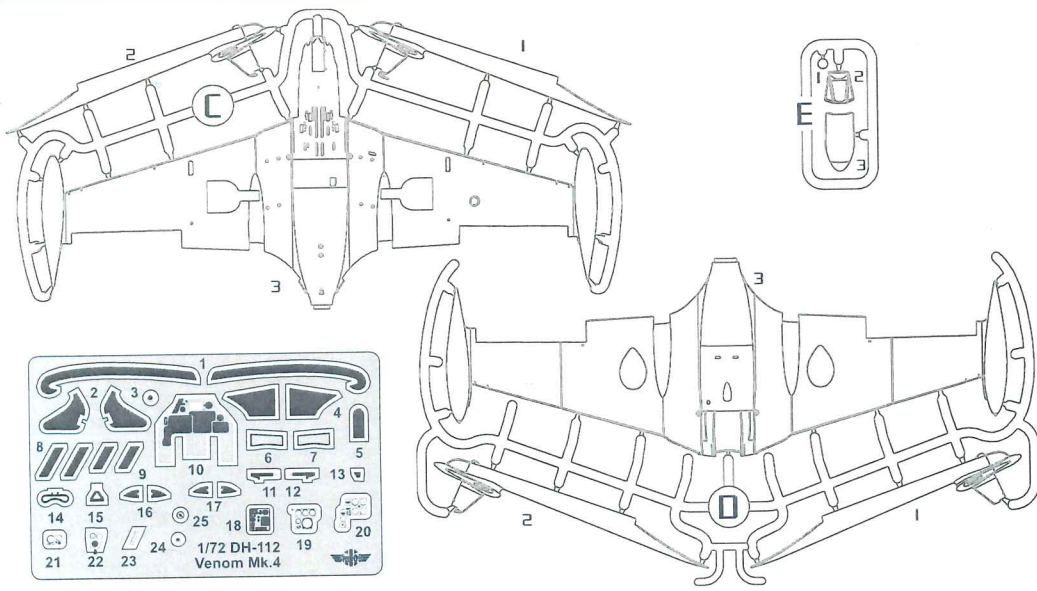

6

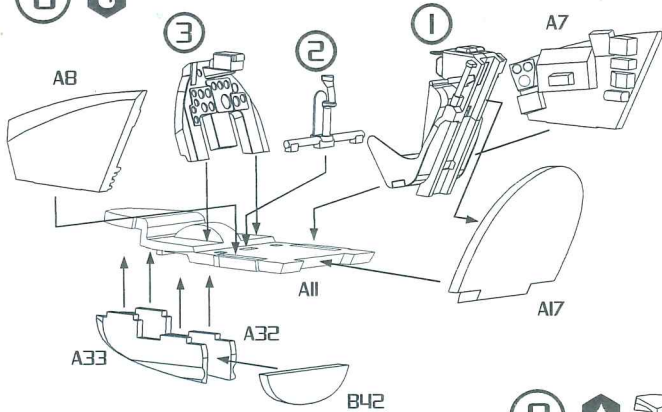

7

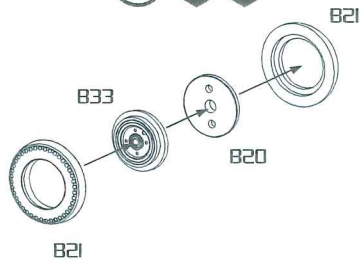

8

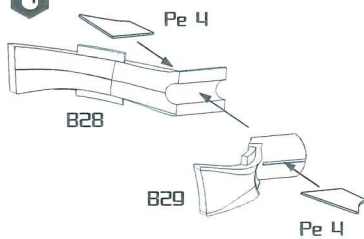

9

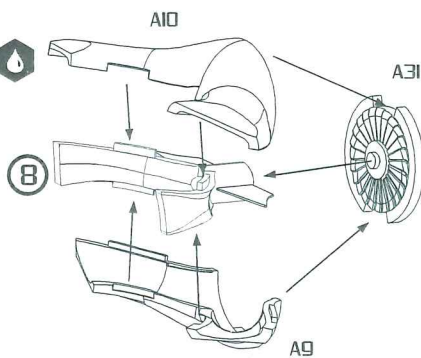

10

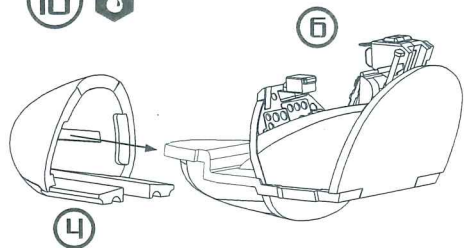

11

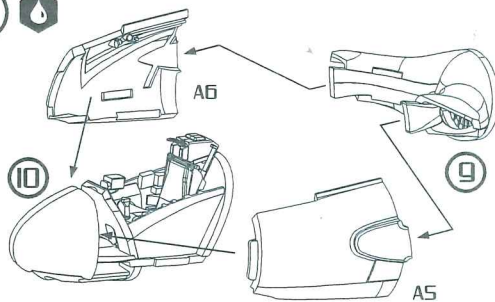

12

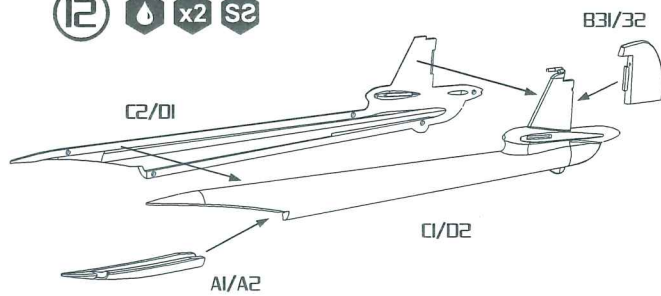

13

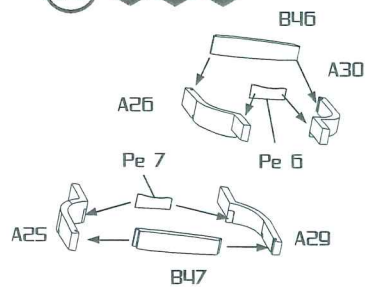



14

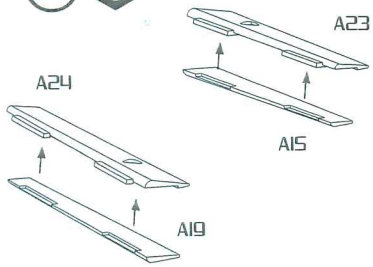

15

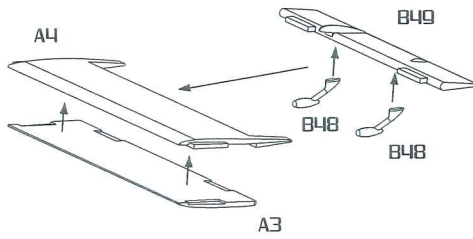

16

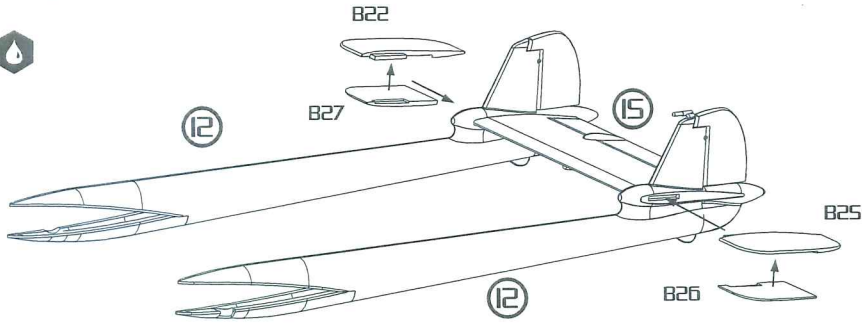

17

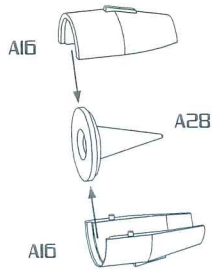

18

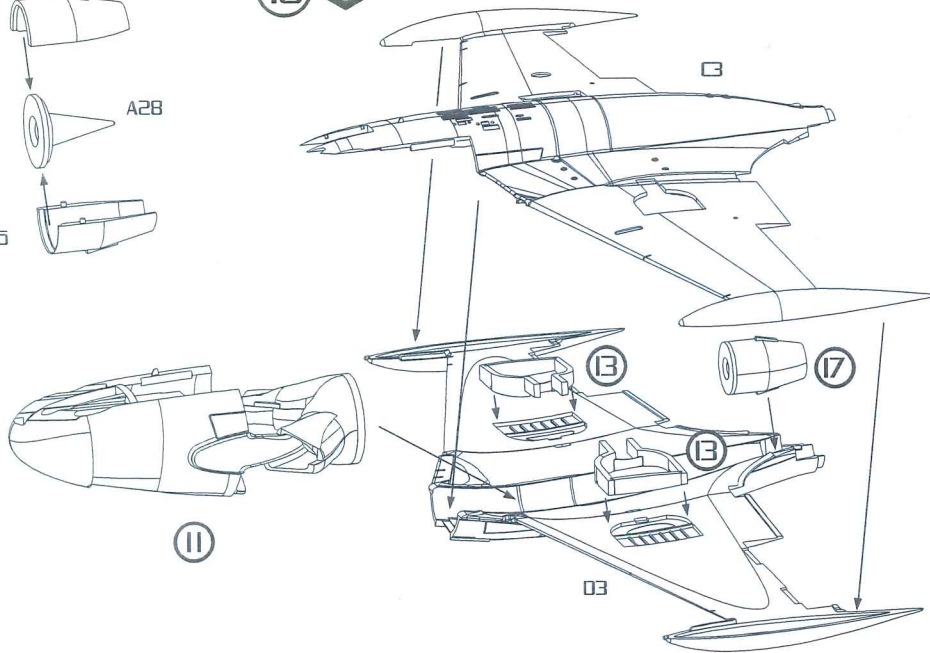

19



Pe 1

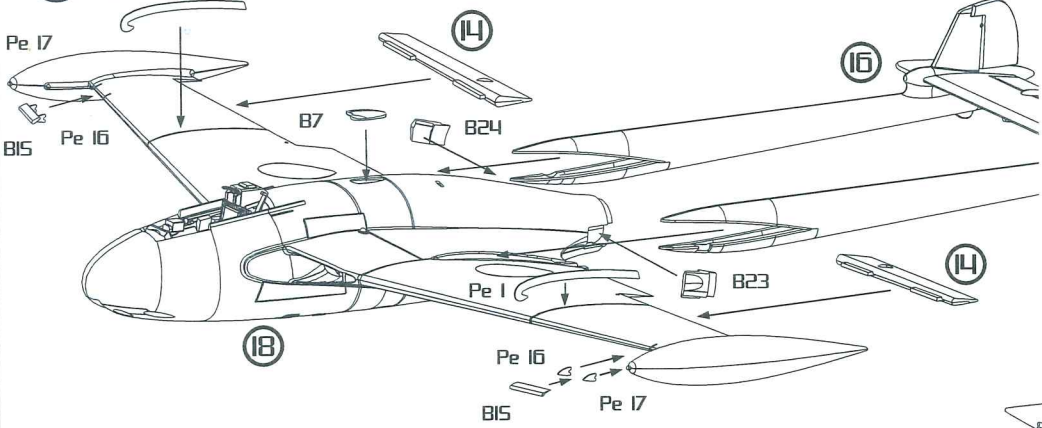

20



S2

7

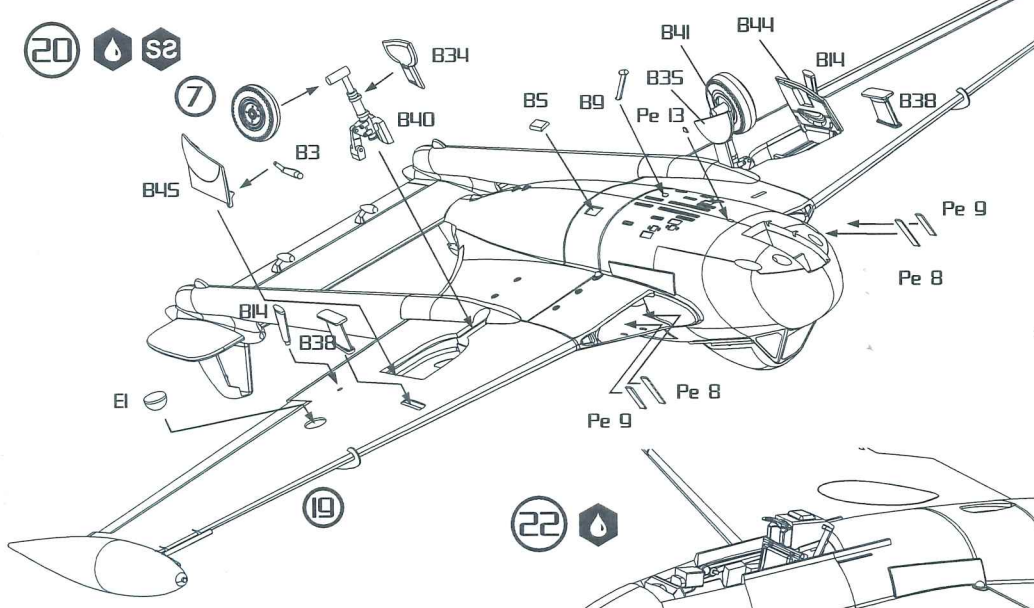

22

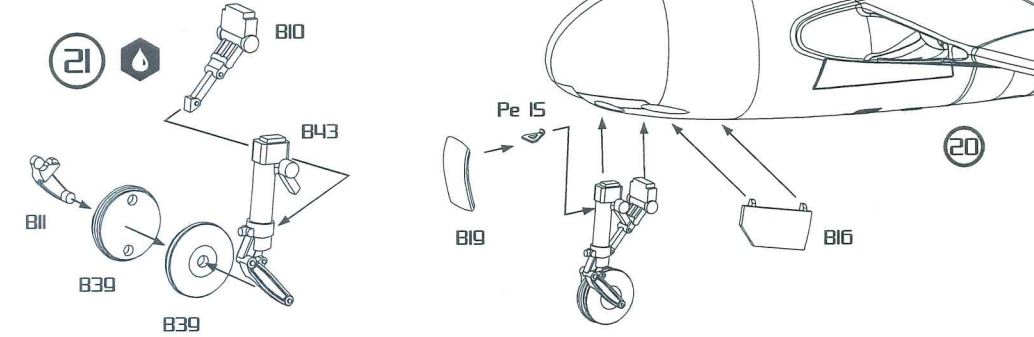

23  x2

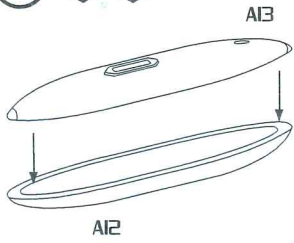

24 

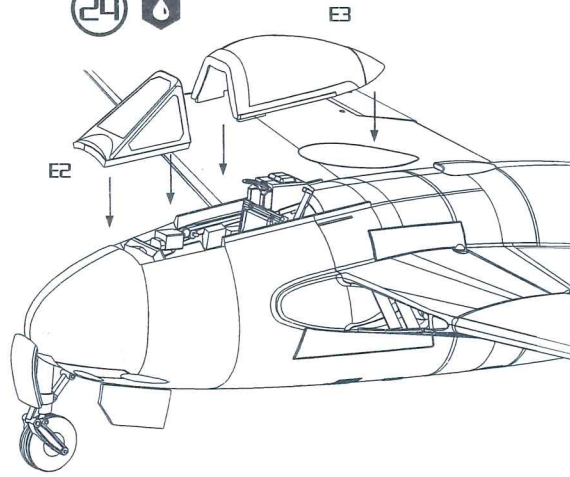

25 

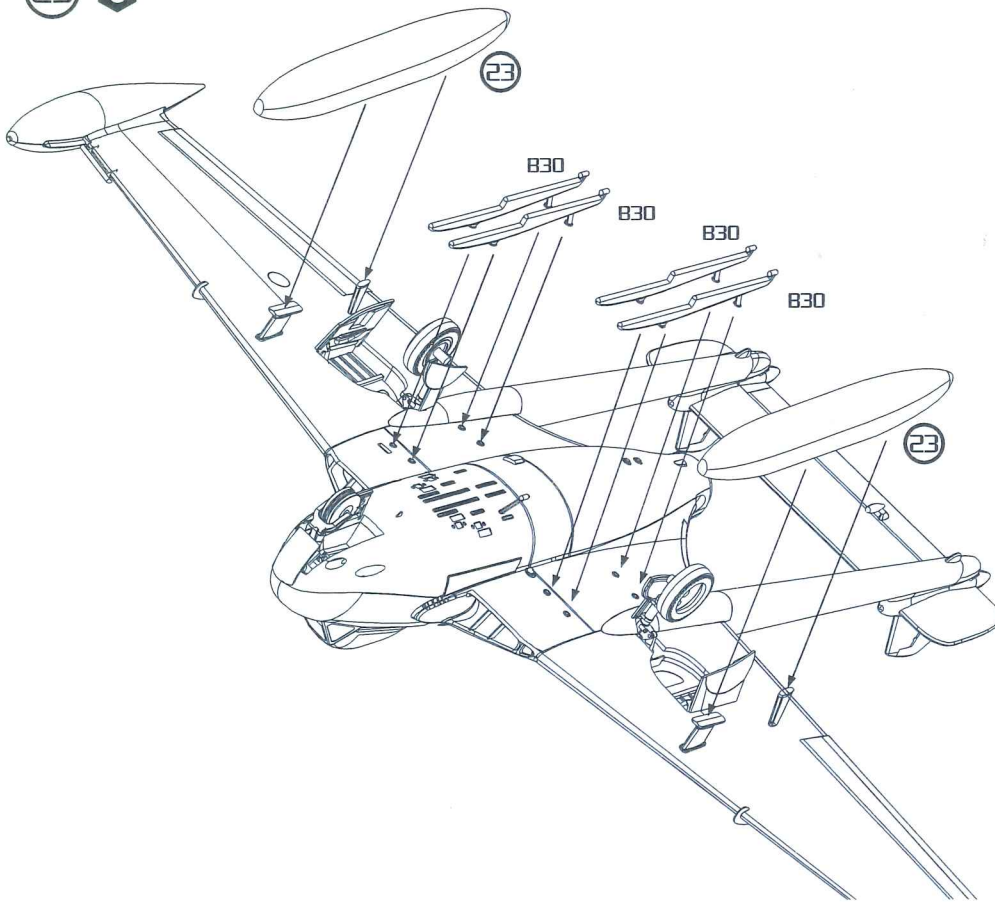

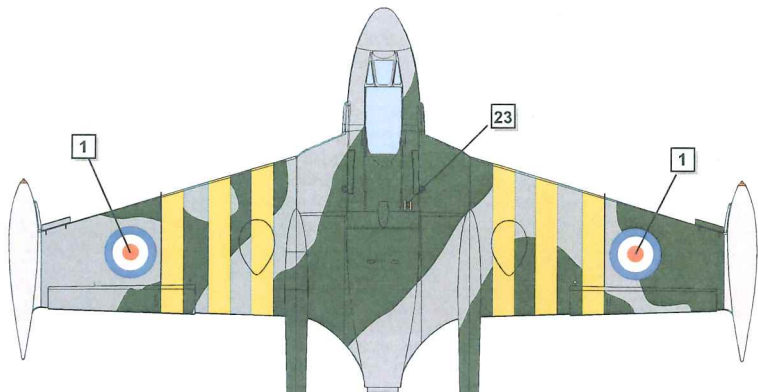
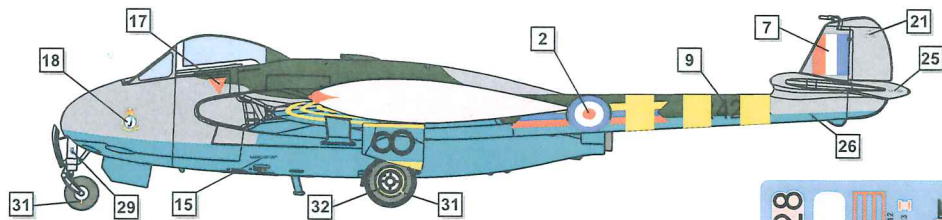

- Dark Sea Grey
- Dark Green
- PRU Blue
- Yellow
- Aluminium

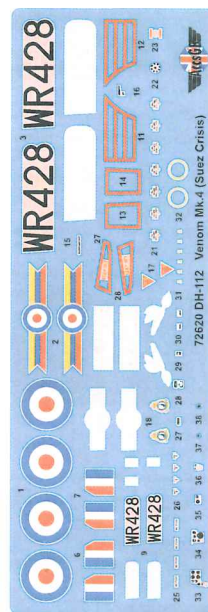
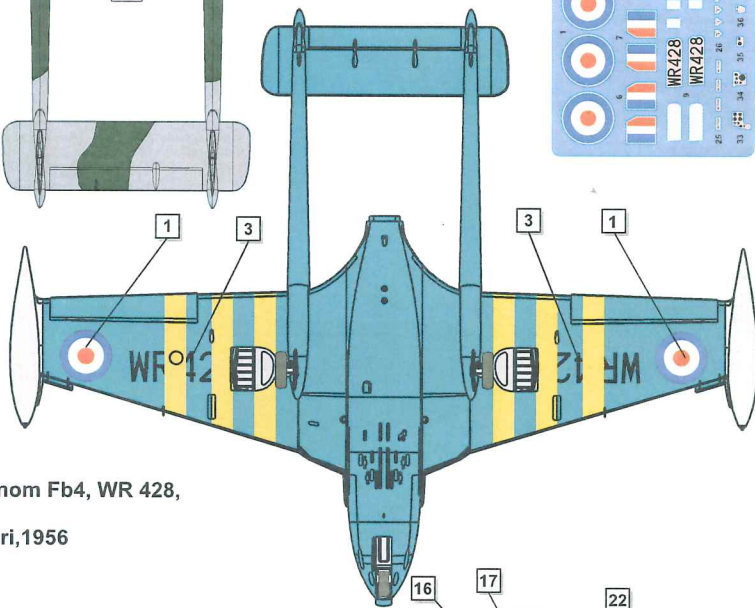

De Havilland DH.112 Venom Fb4, WR 428,  
Operation "Musketeer",  
8 Squadron RAF, Akrotiri, 1956

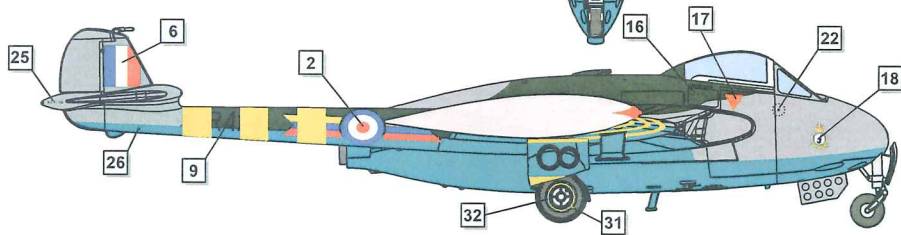



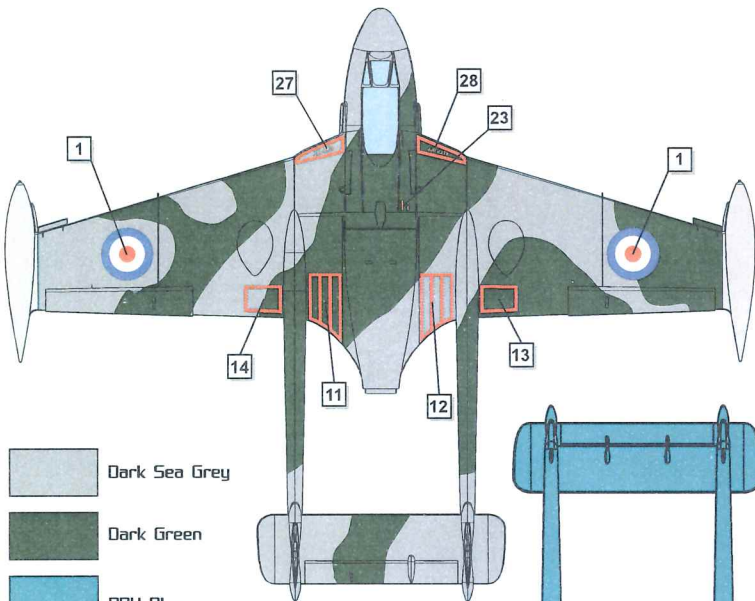
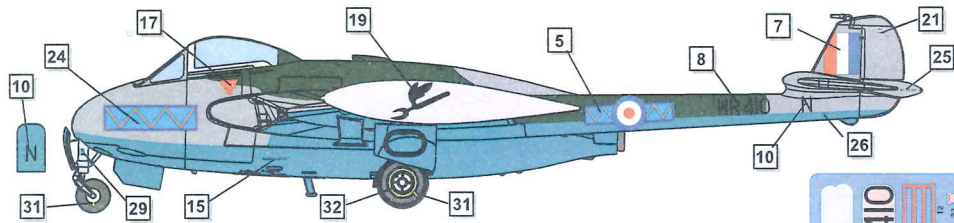

- Dark Sea Grey
- Dark Green
- PRU Blue
- Aluminium

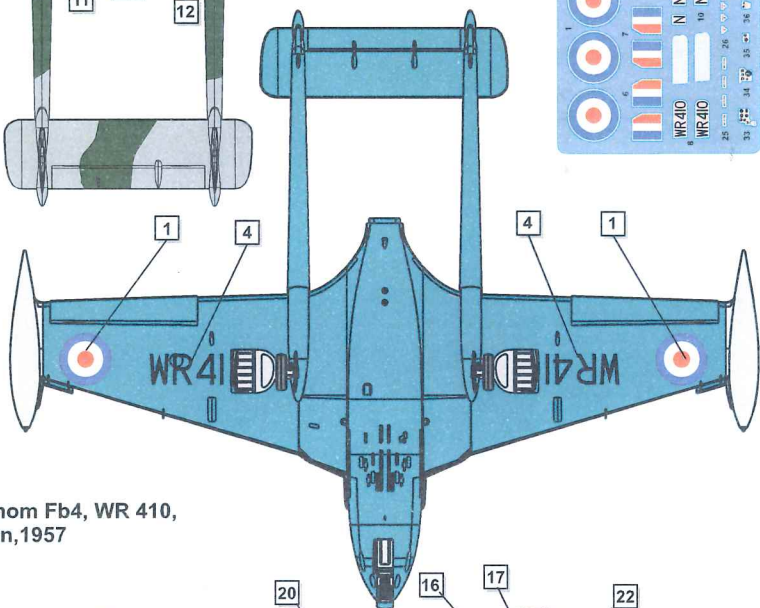
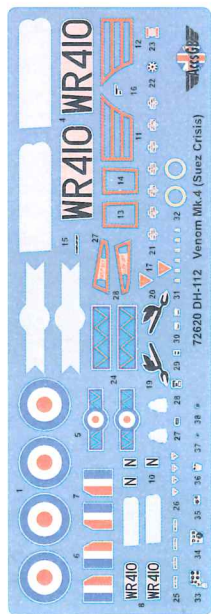

De Havilland DH.112 Venom Fb4, WR 410,  
6 Squadron RAF, Bensen, 1957

