



Savoia-Marchetti S.55

1/72 SCALE MODEL CONSTRUCTION KIT

Ready to assemble scale models kit.
 Contains part for one model.
 Model length: 225 mm
 Wingspan: 332 mm
 Plastic parts: 186
 Photographed parts: 29

The Savoia-Marchetti S.55 was a double-hulled flying boat produced in Italy, beginning in 1924. Shortly after its introduction, it began setting records for speed, payload, altitude and range. In 1927, the Santa Maria under Francesco de Pinedo. After flying south to Bolama, at that time in Portuguese Guinea, they hoped to cross the ocean without another stop but were forced down at Cape Verde, reaching Brazil on 23 February 1927. After the crossing, the aircraft was traded to Brazil for coffee beans.
 The Brazilian João Ribeiro de Barros and his crew of three made another crossing in S.55 "Jahú" on 24 April 1927. Departing from Santiago Island, he crossed the Atlantic in "Jahú" and landed at Fernando de Noronha Island, Brazil.
 Pilots Francesco de Pinedo and Carlo del Prete took off from Sesto Calende, Italy, in an S-55. Four months later, they arrived back in Italy, having flown nearly 48,280 km (30,000 mi) in 193 flying hours and having made just over 30 stops, including Rio de Janeiro, Buenos Aires and New York City. Numbered "L-23" Dora Wings company thanks for the help in creating the model **Maxim Lysak** (Switzerland) and **Martino De Bortoli** (Italy).

PARTS OF THE MODEL

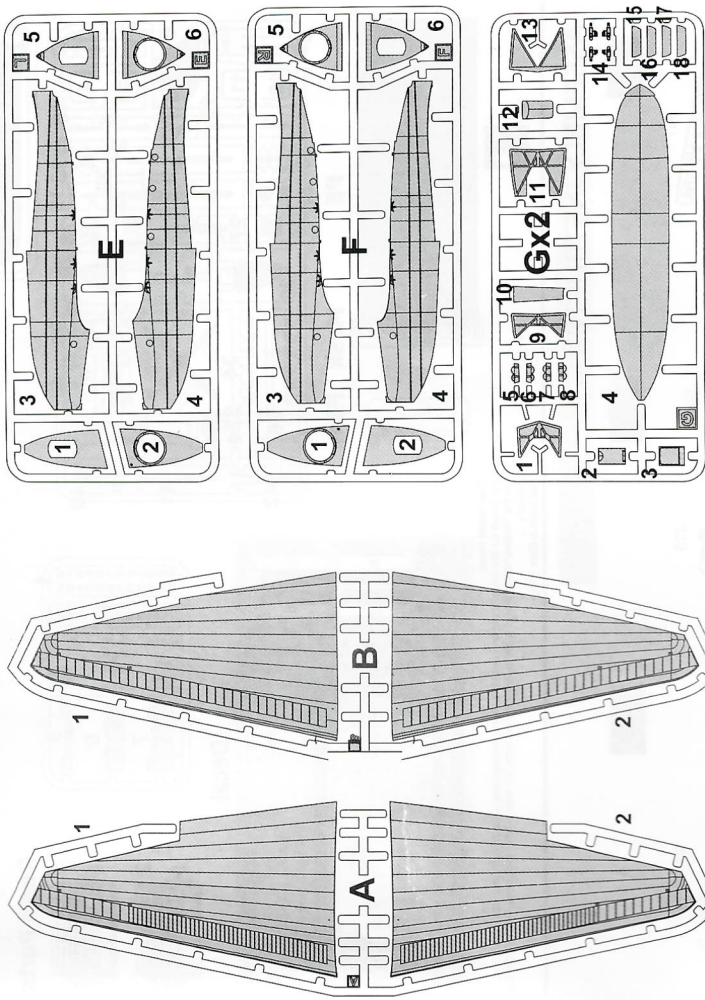

USED SYMBOLS



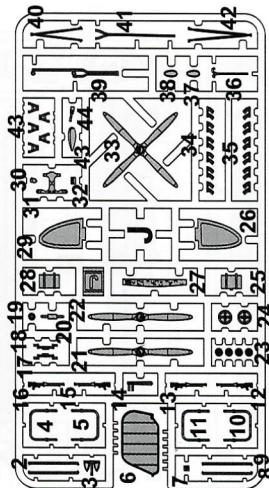
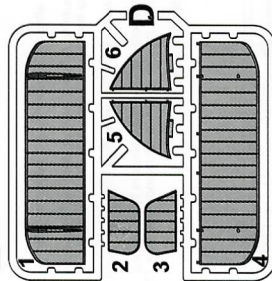
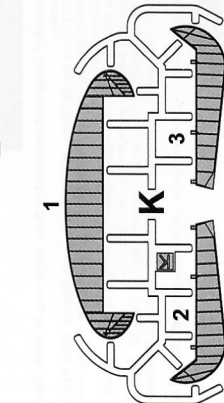
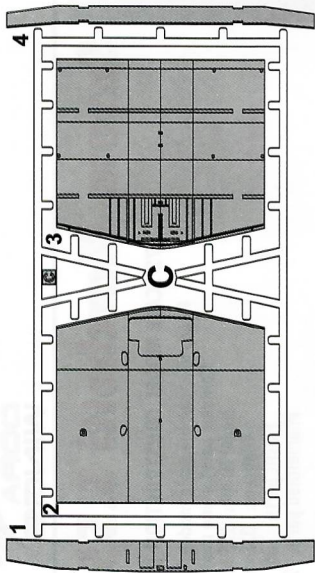
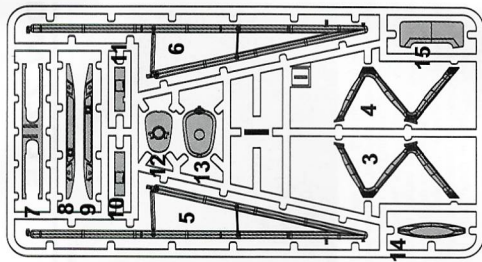

Resin Parts

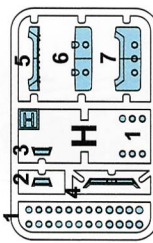
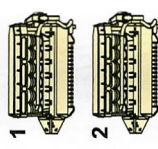

Decal

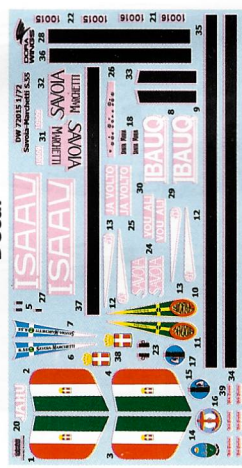

Mask Film



Dear model friends, in this model there is an option ISAAV. Perhaps you want to make this particular option. Since the "Alicione" had floats of a completely different form, we cannot offer this option. But we offer the opportunity... Your team is Dora Wings.

ASSEMBLY INSTRUCTION

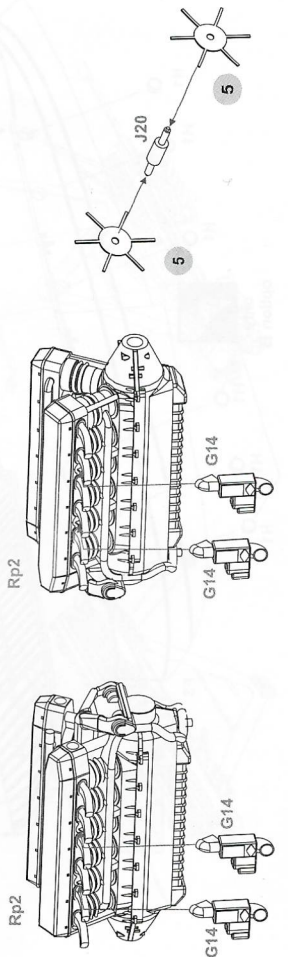
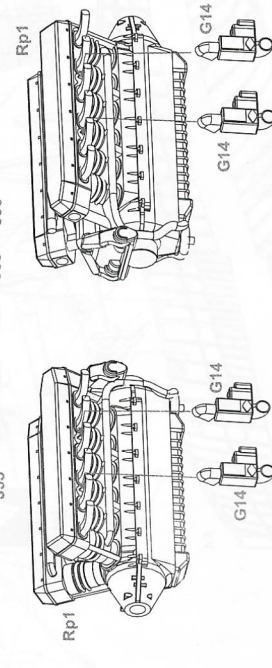
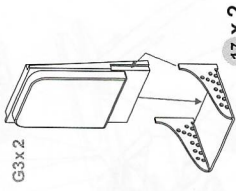
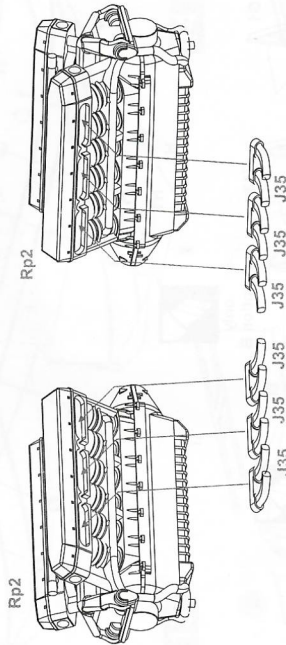
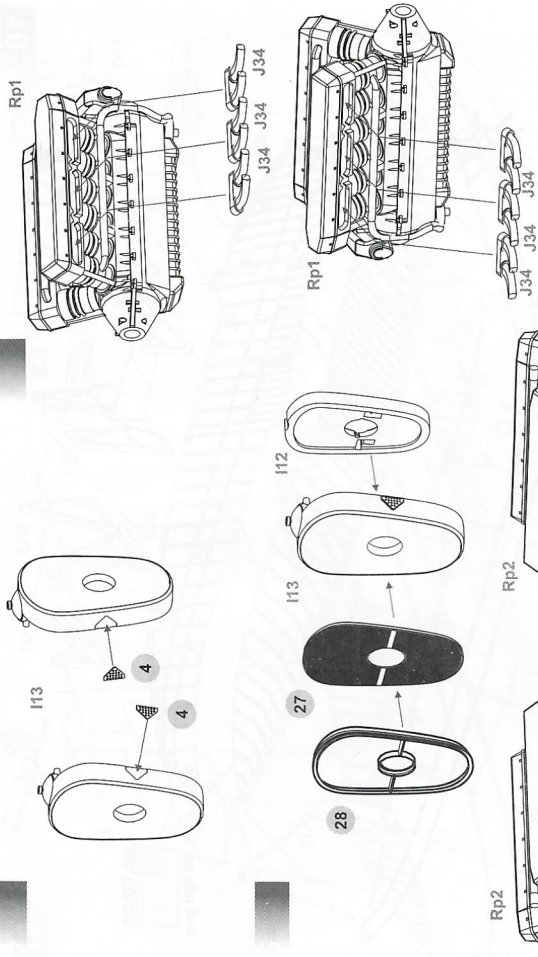
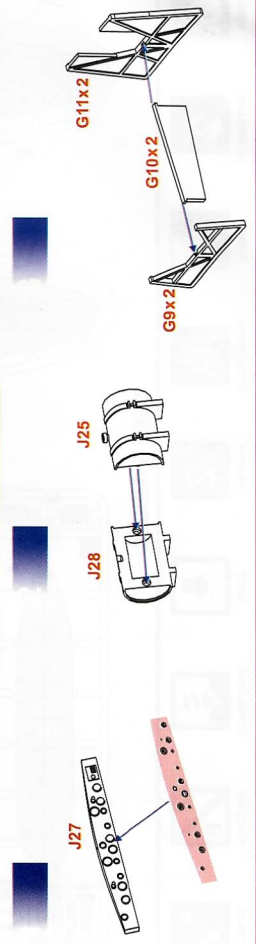

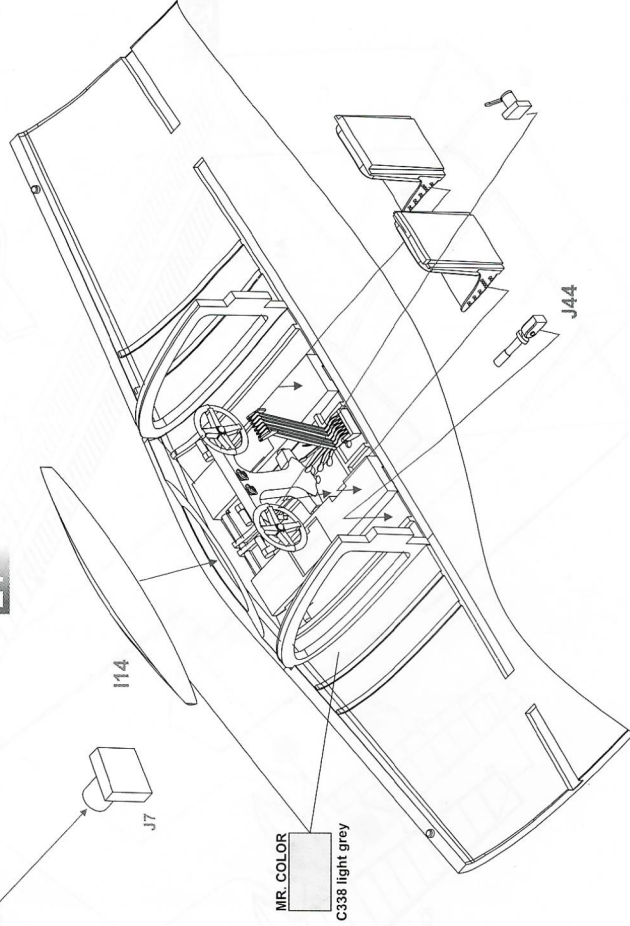
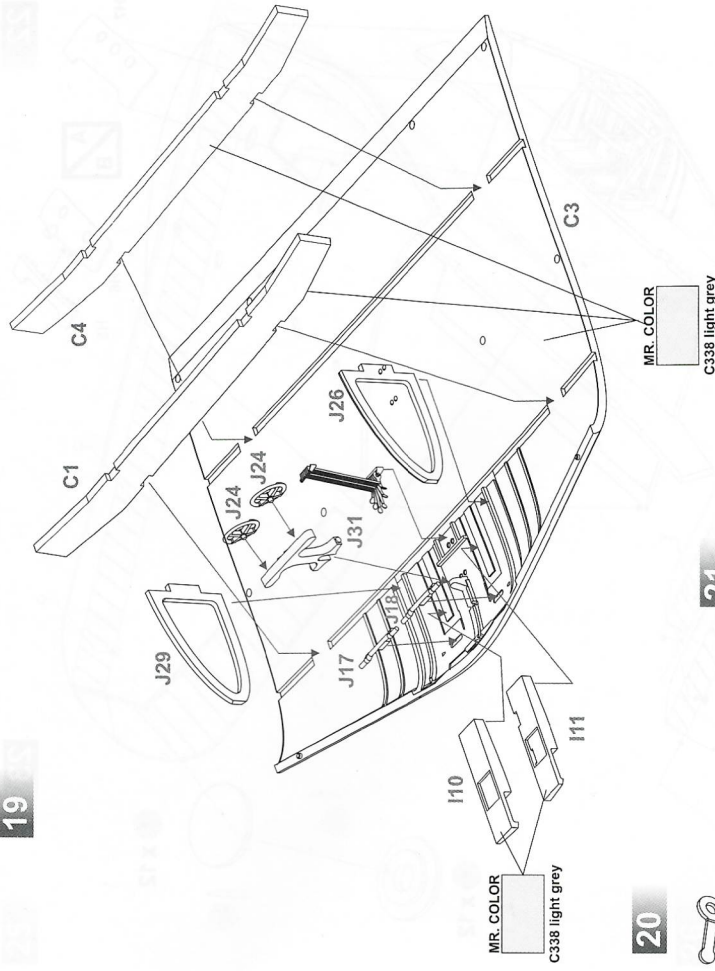
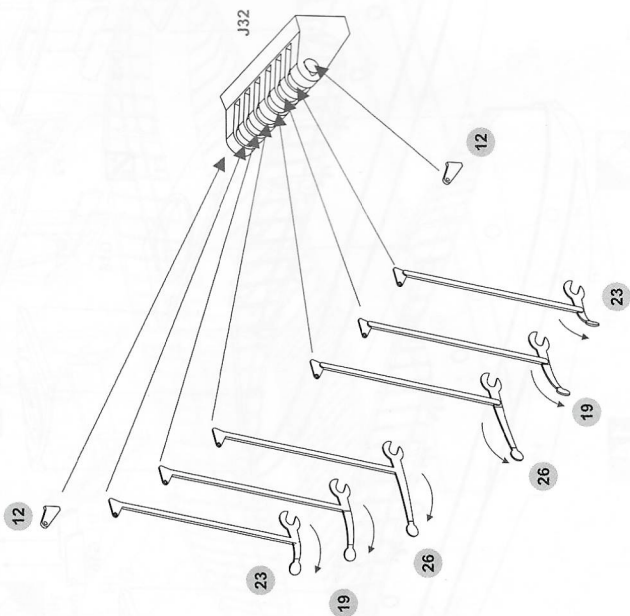

22

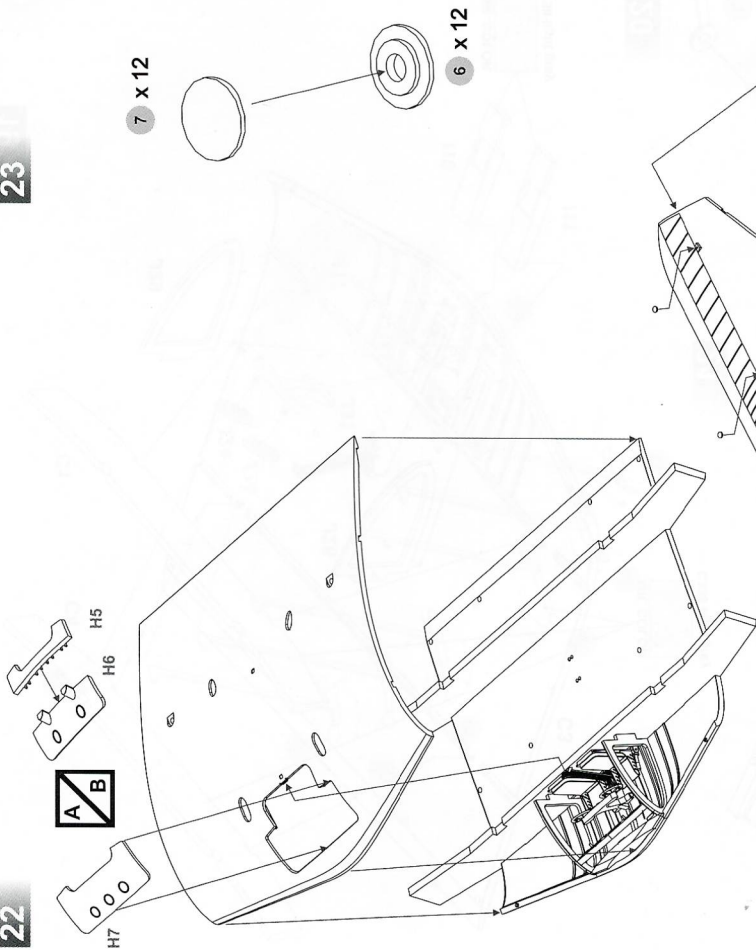

23

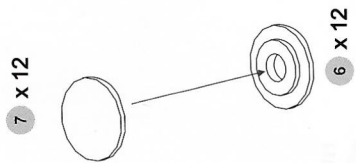

24

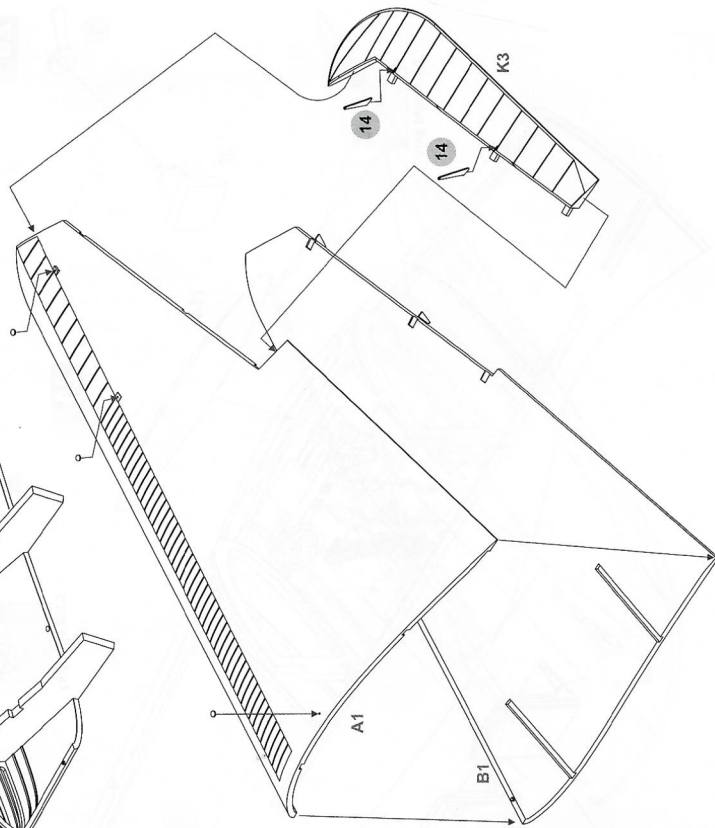

25

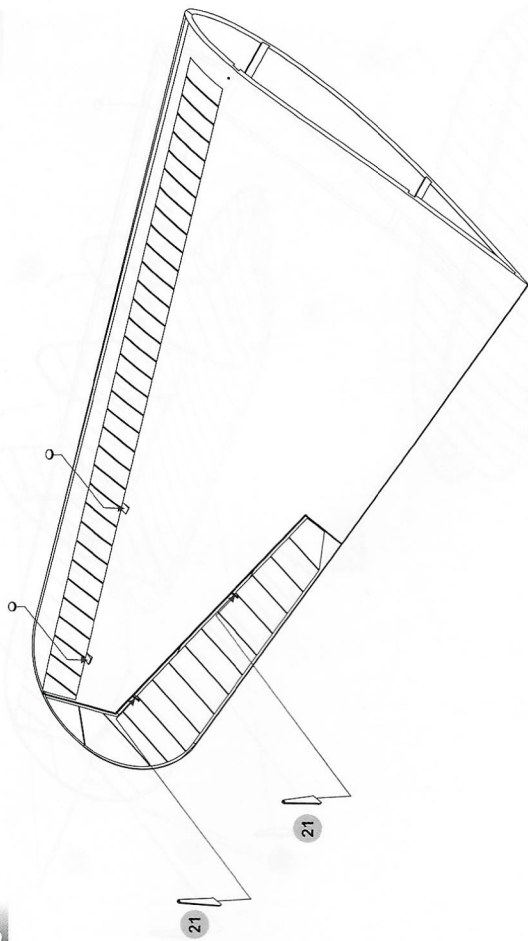

26

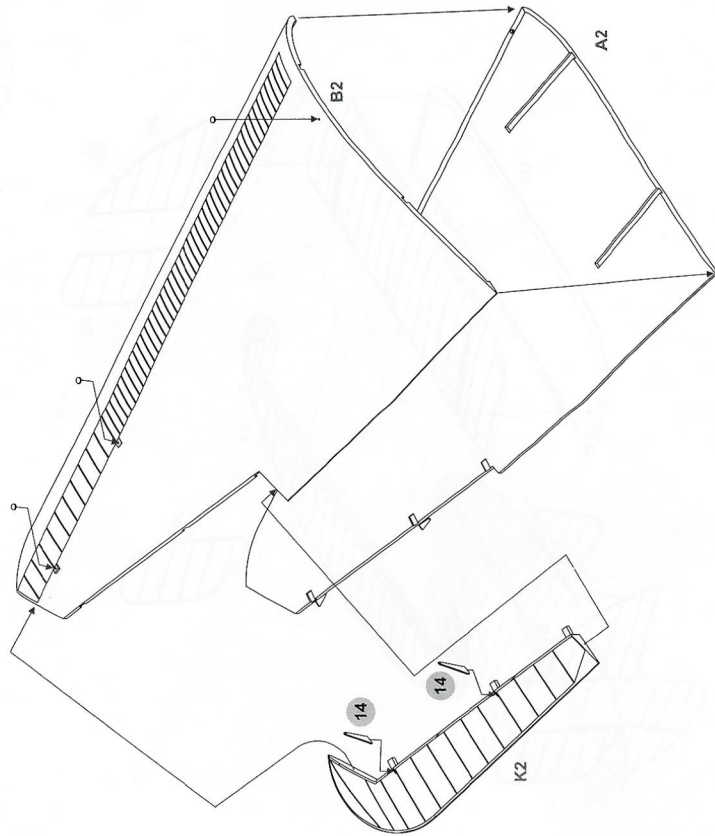

27

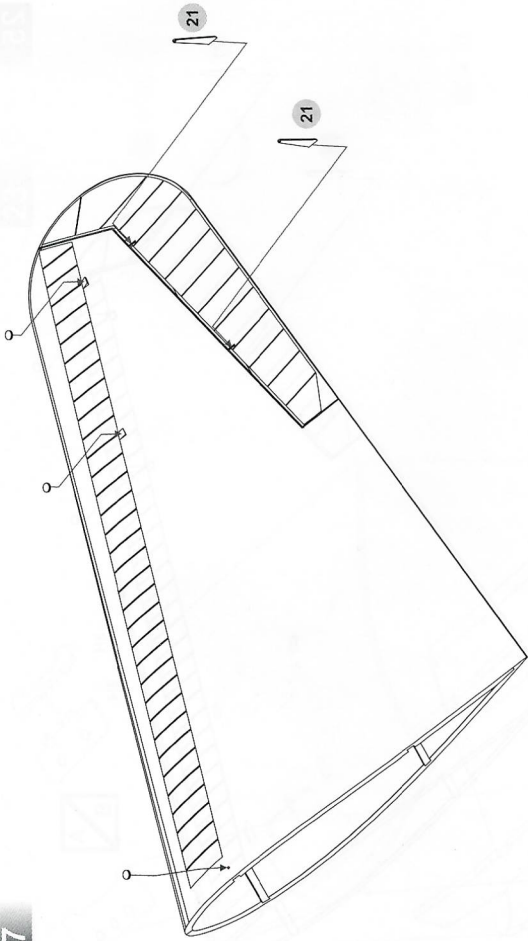

28

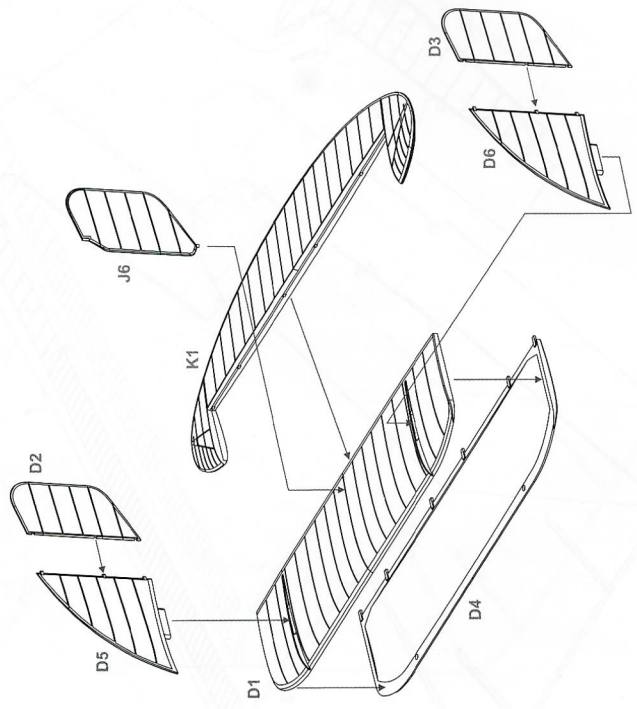

29

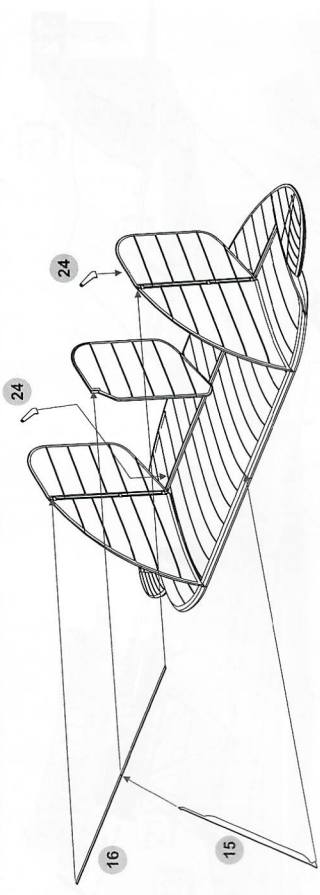

30

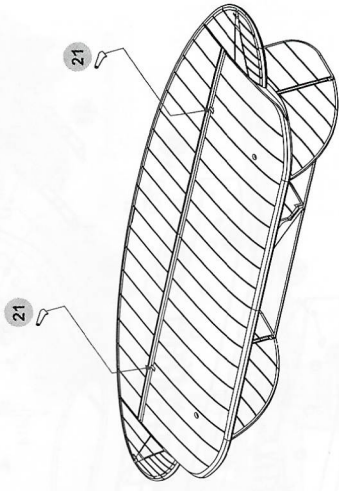

31

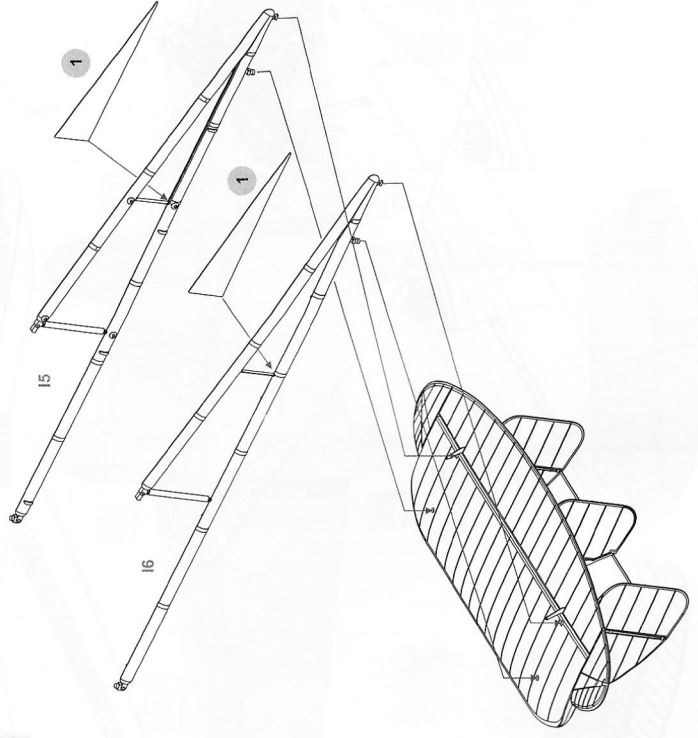

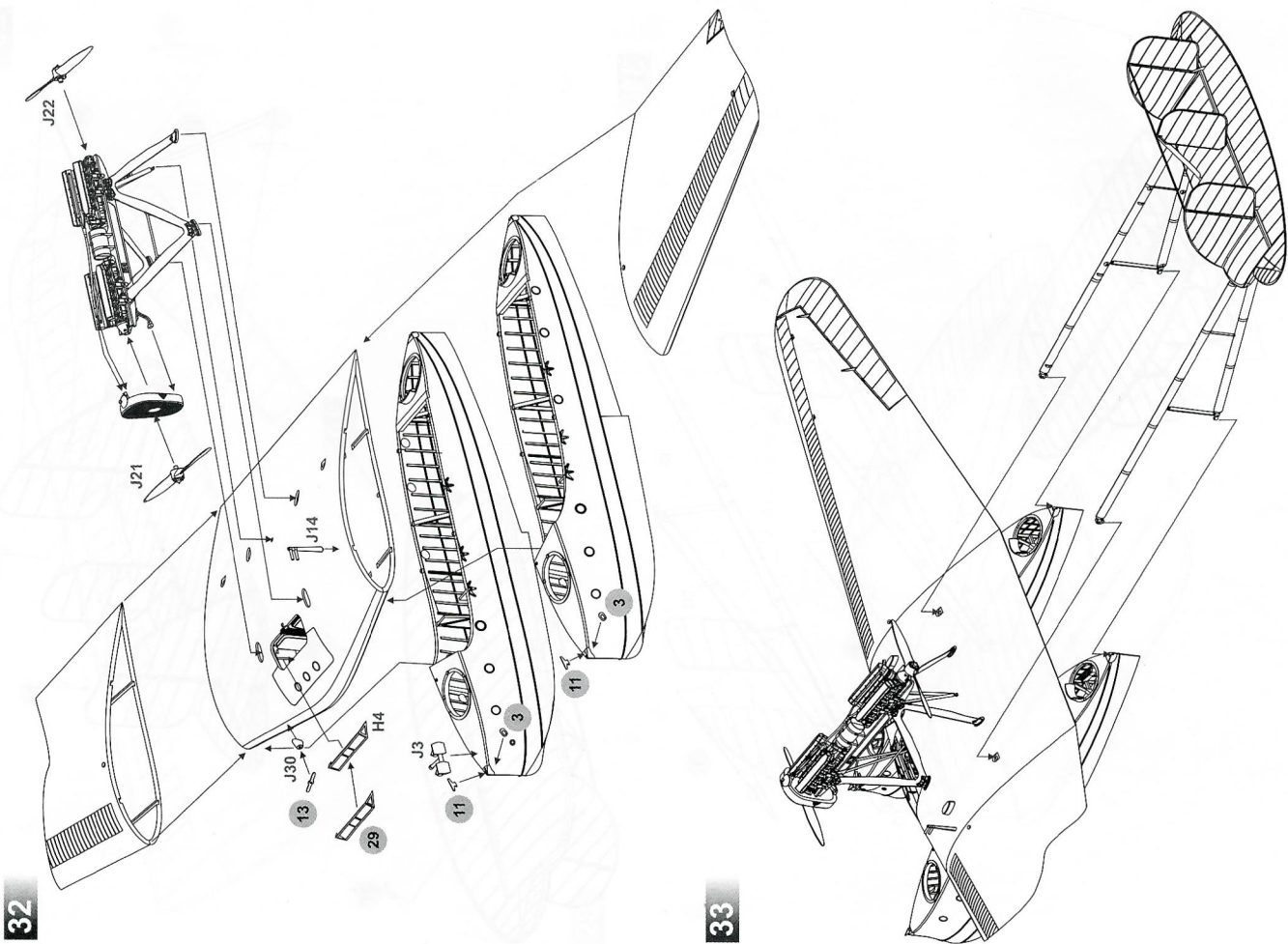
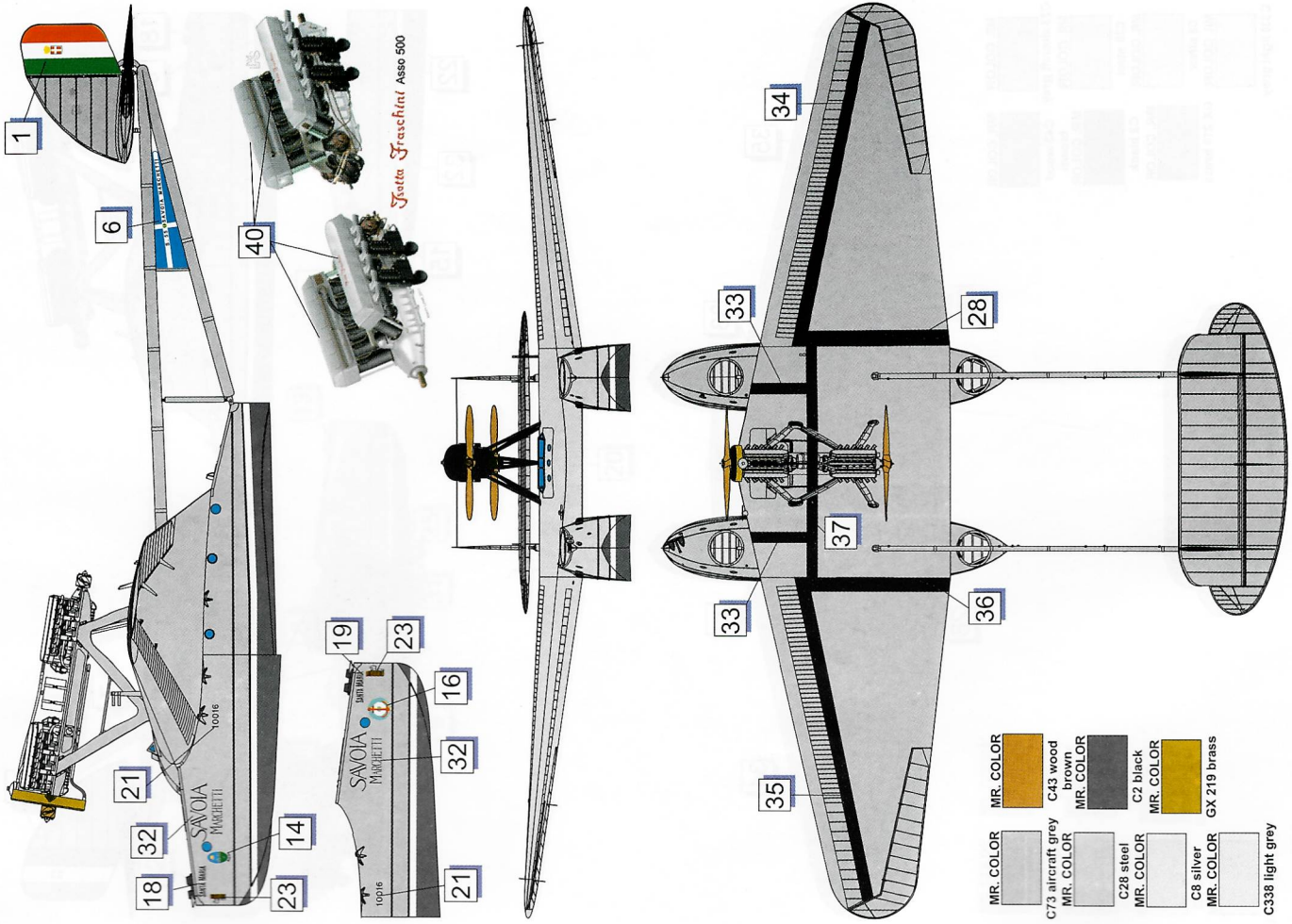

4.S.55 Santa Maria II, registration number 10016. Replacing Santa Maria, which was sent after the fire to Santa Maria on April 19. May 8, 1927.

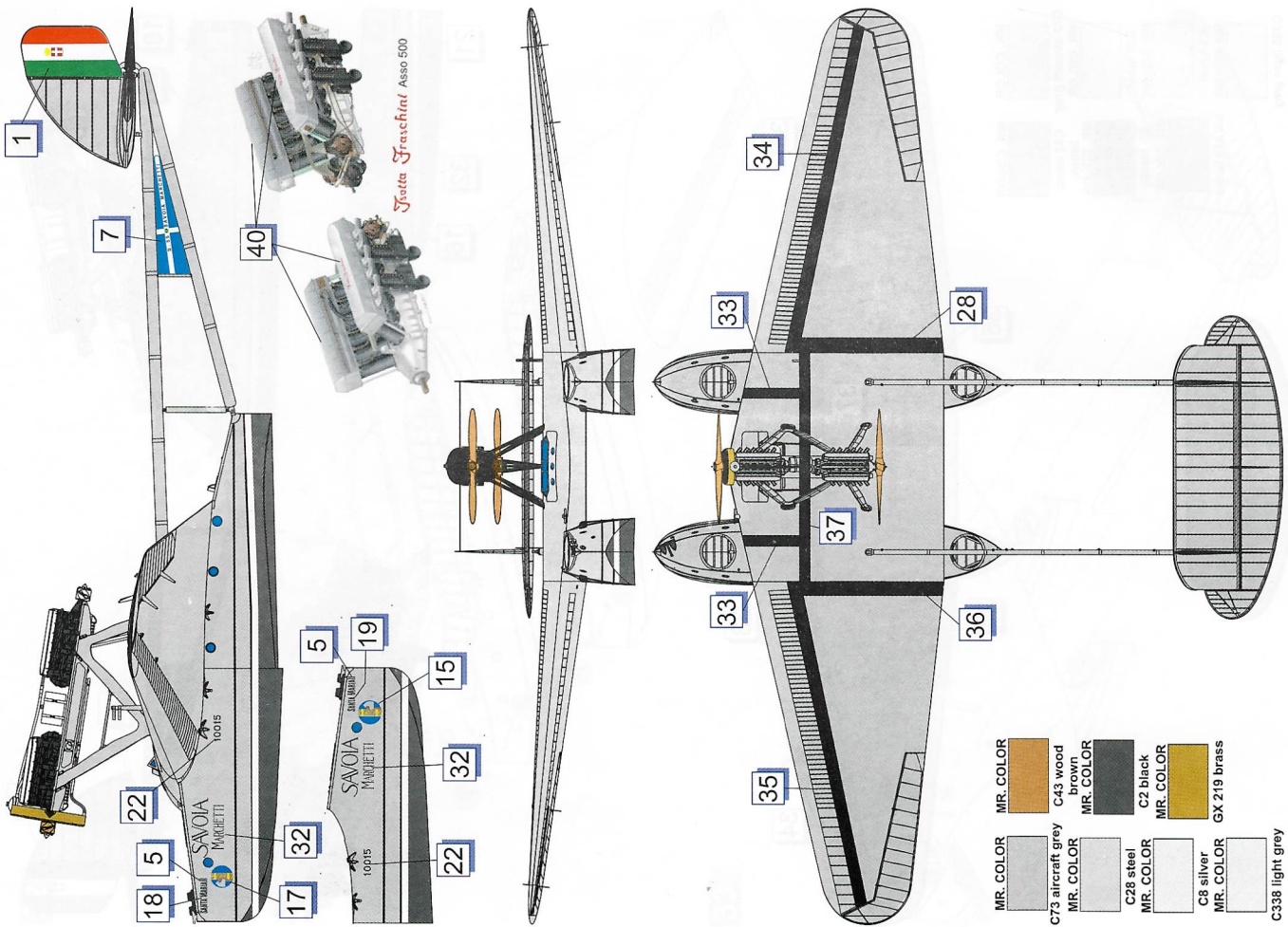

2. S.55 JAHU, registration number I-BAUQ (ex- I-SAAV). Flight across the Atlantic, April 28, 1927. Pilot: João Ribeiro de Barros.

